

NOTE(S):
1. PART NUMBER, "/00" DENOTES PART SHALL HAVE FINISH.

2. APPLY NSF COMPLIANT GREASE TO ANY O-RING, SEALING JOINTS, AND/OR PIVOTAL POINTS.

3. APPLY NSF COMPLIANT LOCTITE TO THREADED AREA.

4. APPLY NSF COMPLIANT REMOVABLE (BLUE) LOCTITE TO THREADED AREA.

5. SILVER SOLDER JOINTS SHALL BE FULLY WETTED VIA CAPILLARY ACTION AND COMPLETELY NON-POROUS.

G
L
B
S

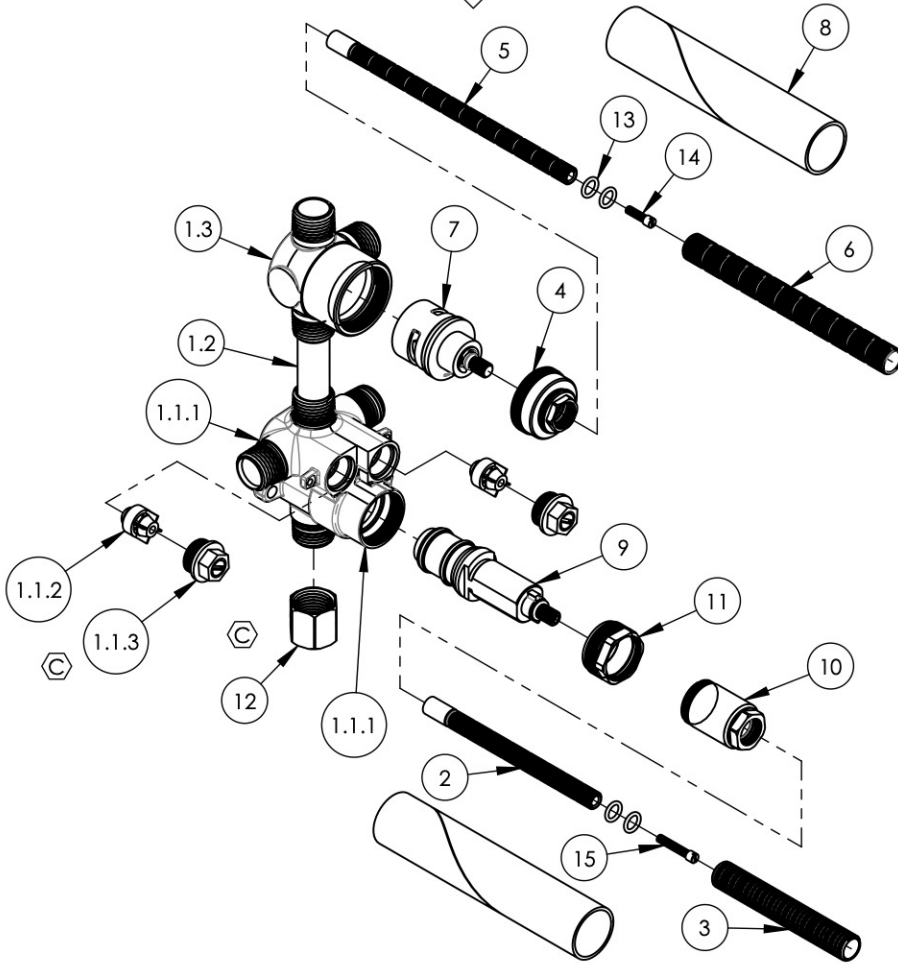

ITEM NO.	PART NUMBER	DESCRIPTION	QTY.
1	2-274	BODY BRAZE, 1/2" THERM W/ 2WAY DIV. RIGHT, 5" C2C	1
1.1	1-113	MINI THERMOSTATIC BODY W/SHUTOFFS	1
1.1.1	10624	BODY, MINI THERMOSTATIC	1
1.1.2	11197	CHECK VALVE INSERT, SPRING LOADED, NV15-15MM OD	2
1.1.3	2-130	SHUTOFF NUT, MINI THERMO	2
1.2	11538	COPPER TUBE, FOR 5" CENTER-CENTER, 2-3/8"L	1
1.3	11579	VALVE BODY, DIVERTER TWO WAY RIGHT PORT, FROM FORGED	1
2	10054	STEM EXTENSION, 6" LONG 20PT INT. TO 16PT LONG EXT. BROACH	1
3	10209	SHANK, NIPPLE THREAD ALL 9/16"-20UN WITH .433"ID	1
4	10349	NUT CAP FOR 3WAY DIVERTER	1
5	11416	STEM EXTENSION, 20PT TO 16PT, XXL	1
6	11498	ALL THREAD, EXTENSION, 9/16"-20, 5-9/16"L, XXL	1
7	11567	CARTRIDGE, DIVERTER, 2WAY, NON-SHARE W/ OFF	1
8	11648	MUD GUARD, CARDBOARD, LONG	2
9	11973	CARTRIDGE MINI-THERM. VALVE, INTEGRATED LIMIT STOP, THERMOSTAR S18 TYP 2	1
10	12073	COVER SLEEVE ADAPTOR, MINI THERM, FOR INTEGRATED LIMIT STOP	1
11	12076	RETAINER NUT, NEW CRTRIDGE W/ INTEGRATED STOP	1
12	30238	HEX CAP, 1/2" NPT	1
13	90011	O-RING, 5/16"ID X 1/16"THK, AS-568-011	4
14	92157	SCREW, SMALL HD M4X0.7 - 1/2"L	1
15	92335	SCREW, FLAT HEAD, M4X0.7 - 1" OVERALL LENGTH	1

C5	C	ADD MINI THERM SUBASSY & HEX CAP	5/7/2021	AMM
ZONE	REV.	DESCRIPTION	DATE	APPROVED
REVISIONS				

1261 LOGAN AVENUE
COSTA MESA, CALIFORNIA 92626
PHONE: 714.361.4800
FAX: 714.617.3120

PHYLIRICH[®]
Defining Luxury Since 1959

PROPRIETARY AND CONFIDENTIAL
THE INFORMATION CONTAINED IN THIS DRAWING IS THE SOLE PROPERTY OF PHYLIRICH. ANY REPRODUCTION IN PART OR AS A WHOLE WITHOUT THE WRITTEN PERMISSION OF PHYLIRICH IS PROHIBITED.

-	-	INTERPRET GEOMETRIC DIMENSIONING & TOLERANCING IN ACCORDANCE WITH ASME Y14.5-2009 & ASME Y14.41-2003 STANDARDS, UNLESS OTHERWISE SPECIFIED. DIMENSIONS ARE IN INCHES. TOLERANCES ARE:		
NEXT ASSY	USED ON	FRACTIONS ±1/16"	DECIMALS X.X: ±.1 X.XX: ±.01 X.XXX: ±.005	ANGULAR ±2°
APPLICATION		MATERIAL	NAME	DATE
FINISH		DRAWN	MAF	5/29/2018
DO NOT SCALE DRAWING		CHECKED		

1/2" MINI-THERMOSTATIC W/ 2-WAY DIVERTER RIGHT, CAL-GREEN

SIZE **A** ASM/PRT NO. **1-132** REV **C**

SCALE: 1:3.75 WEIGHT: lbs. SHEET 1 OF 2

NOTE(S):

1. FOR DEEPER ESCUTCHEON:

- A. 3-353/00
- B. 92401

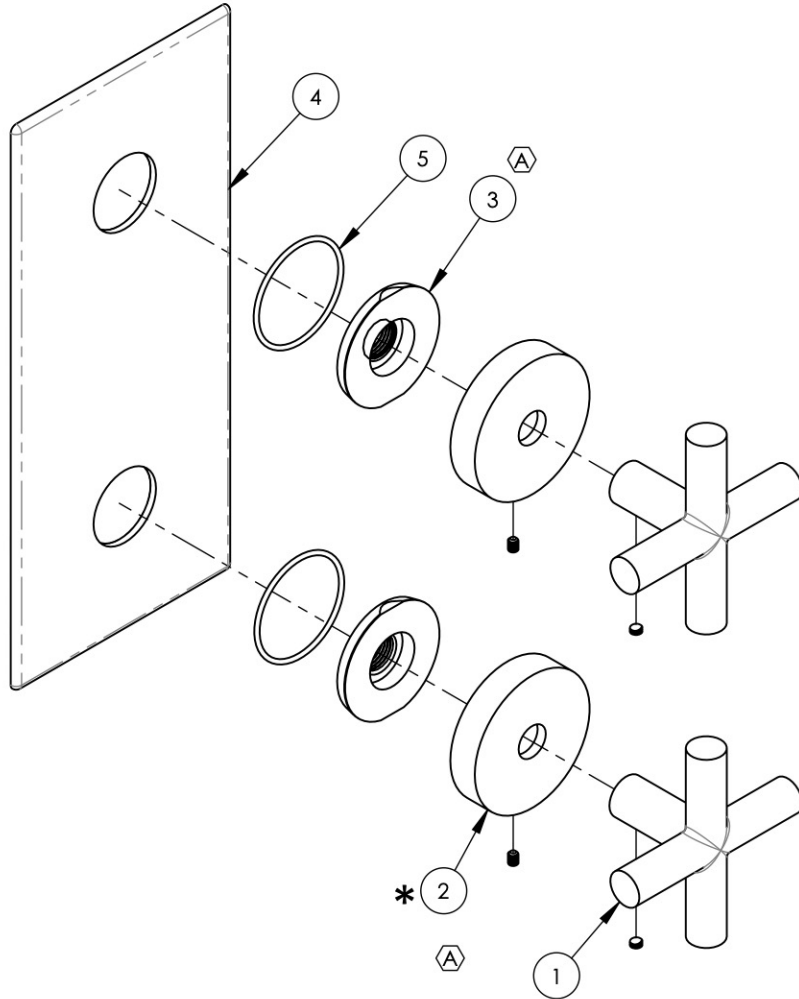

ITEM NO.	PART NUMBER	DESCRIPTION	QTY.
1	3-580/00	HANDLE CROSS W/ SET SCREW, TRANSITION	2
* 2	3-590/00	ESCUTCHEON W/ SET SCREW, TRANSITION	2
3	11003	SLEEVE MOUNT, WALL MT WIDESPREAD	2
4	11204/00	PLATE, TWO HANDLE FLAT RADII EDGE	1
5	90029	O-RING, 1-5/8"ID X 1-3/4"OD X 1/16"THK, AS-568-029	2

ZONE	REV.	DESCRIPTION	DATE	APPROVED
B3, D3, E5	A	UPDATE SLEEVE MOUNT & ESCUTCHEON HUBS, ADD NOTES	3/13/2020	AMM
REVISIONS				

1261 LOGAN AVENUE
COSTA MESA, CALIFORNIA 92626
PHONE: 714.361.4800
FAX: 714.617.3120

PHYL RICH[®]
Defining Luxury Since 1959

PROPRIETARY AND CONFIDENTIAL
THE INFORMATION CONTAINED IN THIS DRAWING IS THE SOLE PROPERTY OF PHYL RICH. ANY REPRODUCTION IN PART OR AS A WHOLE WITHOUT THE WRITTEN PERMISSION OF PHYL RICH IS PROHIBITED.

-	-	INTERPRET GEOMETRIC DIMENSIONING & TOLERANCING IN ACCORDANCE WITH ASME Y14.5-2009 & ASME Y14.41-2003 STANDARDS, UNLESS OTHERWISE SPECIFIED. DIMENSIONS ARE IN INCHES. TOLERANCES ARE:		
NEXT ASSY	USED ON	FRACTIONS ±1/16"	DECIMALS X.X: ±.1 X.XX: ±.01 X.XXX: ±.005	ANGULAR ±2°
APPLICATION		MATERIAL	NAME	DATE
FINISH		DRAWN	AMM	12/5/2019
DO NOT SCALE DRAWING		CHECKED		

THERM, SHOWER TRIM, TWO HANDLE - CROSS, TRANSITION

SIZE	ASM/PRT NO.	REV
A	4-012/00	A
SCALE: 1:2.5	WEIGHT: lbs.	SHEET 1 OF 2