

NOTES:

- (N1) 1. FIT / FORM / FUNCTION SHALL FOLLOW PS-E.008.
- 2. APPLY LIGHT FILM OF DOW CORNING 111 SILICONE COMPOUND
- 3. WHEN TIGHTENING ITEM 3 IN ASSY , APPLY 50-60 LB-IN OF TORQUE

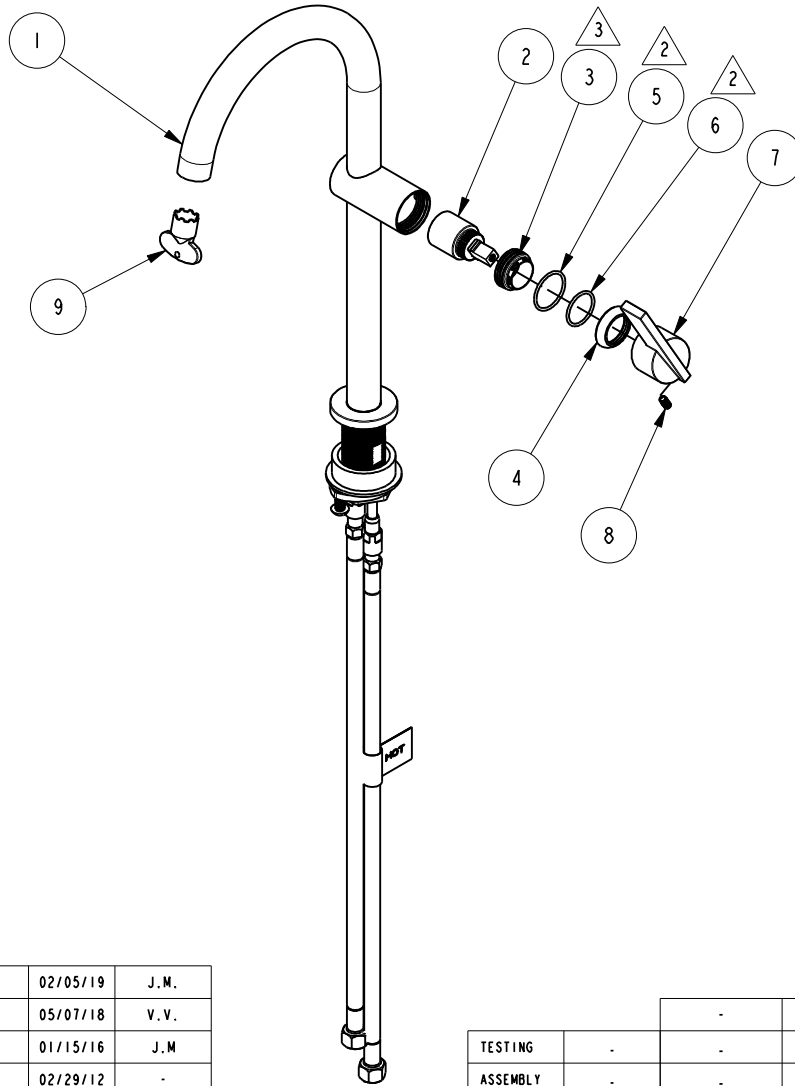

BILL OF MATERIAL (CURRENT LEVEL)

ITEM	PT/ASSY	DESCRIPTION	TYPE	QTY.
1	3-400	D/L - SPOUT ASM LONG	ASSEMBLY	1
2	1-242	CARTRIDGE 25 MM KCG K025a	PART	1
3	11706	D/L - BALL NUT	PART	1
4	11767	DECORATIVE COVER	PART	1
5	91024	O-RING, #2- 022, EPDM, 65-75 DURO	PART	1
6	91217	O-RING, #2-020, EPDM, 65-75 DURO, NSF 61	PART	1
7	11768	HANDLE LEVER	PART	2
8	92090	SCRW, 10-32 X 3/8 SKT HD CUP PT W/ SELF LOC SS	PART	1
9	91571	AERATOR KEY	PART	1

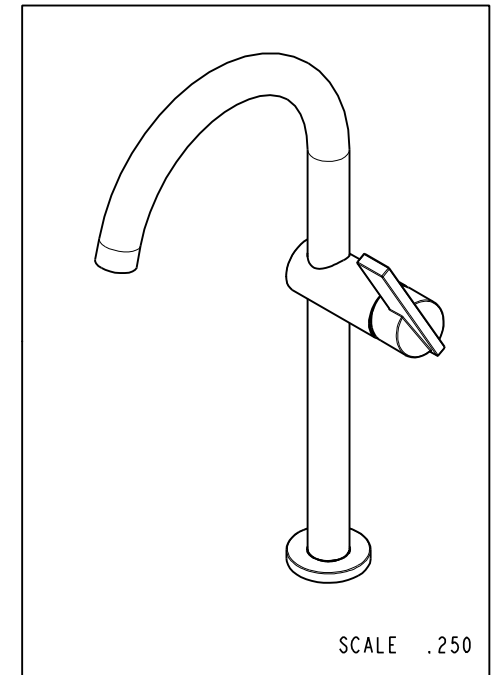

-	F	EN-3623a	02/05/19	J.M.
-	E	EN-3601	05/07/18	V.V.
-	D	EN-2643	01/15/16	J.M
-	C	EN-2084	02/29/12	-
-	B	EN-1940	10/24/11	-
-	A	EN-1853	08/25/11	-
-	-	EN-0995-3	01/31/11	-
ZONE	REV	DESCRIPTION	DATE	APPROVED

COPYRIGHT 2005 BRASSTECH, INC. THESE DRAWINGS AND THE DESIGNS DEPICTED HEREIN ARE THE PROPRIETARY PROPERTY OF BRASSTECH. ANY USE OR REPRODUCTION IS SUBJECT TO THE EXPRESS APPROVAL OF BRASSTECH. UNAUTHORIZED USE IS STRICTLY PROHIBITED. ALL RIGHTS RESERVED.

TESTING	-	-	-
ASSEMBLY	-	-	-
PLATING	-	-	-
POLISHING	-	NEXT ASSY	USED ON
MACHINING	-	APPLICATION	
TOOLING FIXTURE #	REMOVE ALL BURRS AND SHARP EDGES		

UNITS ARE: INCHES [MM]  
TOLERANCES ARE:  
FRACTIONS DECIMALS ANGLES  
 $\pm 1/16"$  .X  $\pm .1$  [2.5]  $\pm 1^\circ$   
.XX  $\pm .06$  [1.5]

(X.XXX) DENOTES CRITICAL DIMS.  
ALL THREADS ARE CRITICAL

DRAWN	JINSON	02/05/19
CHECKED	J.M.	02/05/19
APPROVED	J.M.	02/05/19

**BRASSTECH** 2001 CARNEGIE AVE.  
INCORPORATED SANTA ANA, CA 92705  
(949) 417-5207

SINGLE HOLE DECK  
LAVATORY-VESSEL

DWG NO. 2413 REV F

SCALE .200 REF. - SHEET 1 OF 2

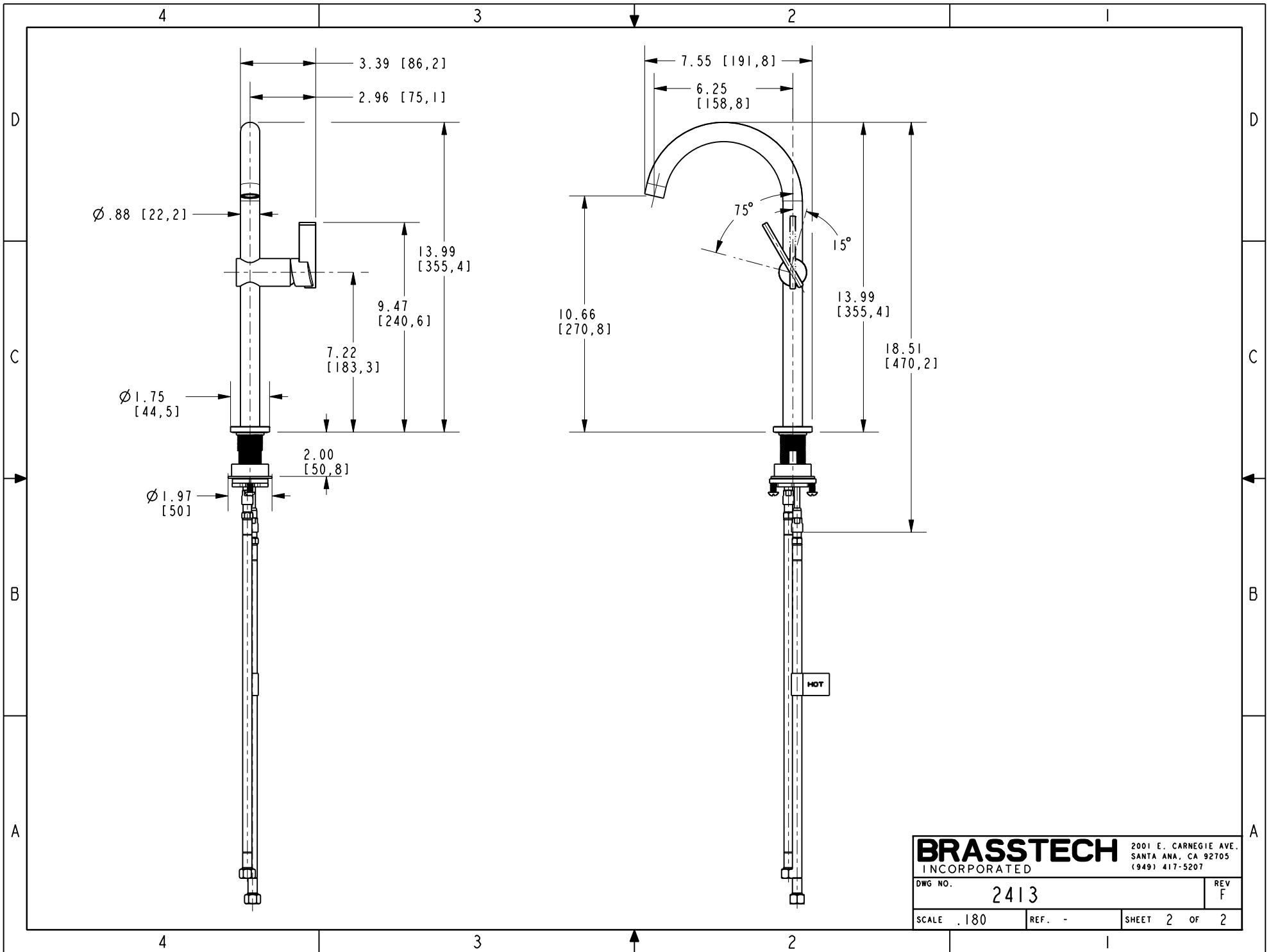

<b>BRASSTECH</b>		2001 E. CARNEGIE AVE.	
INCORPORATED		SANTA ANA, CA 92705	
DWG NO. 2413		REV F	
SCALE .180	REF. -	SHEET 2 OF 2	