

Edition 300

30018010000 Towel Bar

PRODUCT



DRAWING

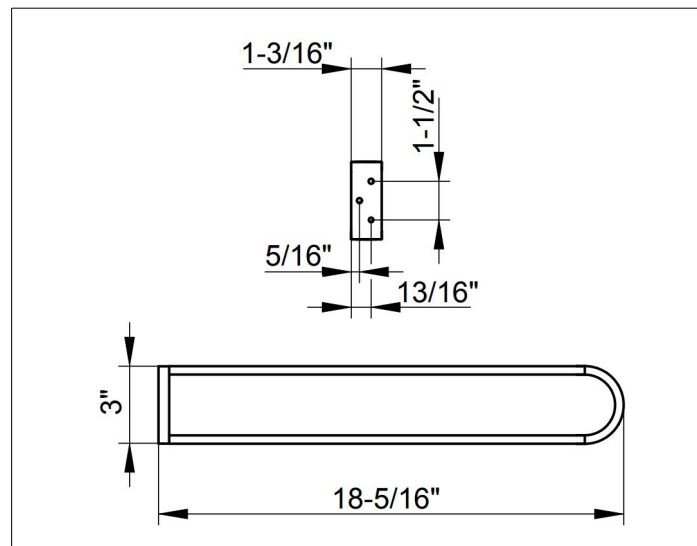

PRODUCT CHARACTERISTICS

Fixed

SURFACE

Chrome

DIMENSION

18.31 in

SPECS

KEUCO EDITION 300 towel holder 30018010000

chrome-plated towel holder in an aesthetic and classic design

two parallel arranged fixed arms

anti static, easy to clean,

projection: 18-5/16"

The towel holder is fitted with two hidden fixing points

2 wall plugs, Fischer FU 1/4" x 1-3/4" and 2 wall screws are supplied