

**AXENT**  
SWITZERLAND

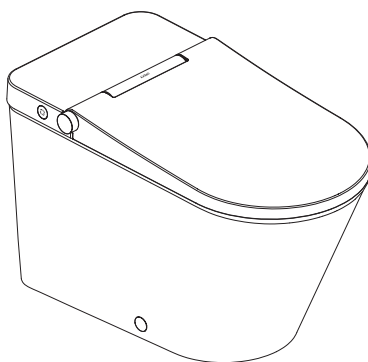

AXENT.ONE C PLUS  
E314  
**USER MANUAL**



## THANK YOU

---

Thank you for selecting an AXENT Switzerland product. To ensure proper installation, please review these instructions carefully before use. Carefully unpack and examine the intelligent toilet before installation. For any questions, contact us at 1-800-769-4857. Thank you again for choosing AXENT.

## BEFORE YOU BEGIN

---

### CAUTION!

---

#### **Risk of personal injury or product damage**

Handle with care. Vitreous china can break or chip if handled carelessly.

All installation procedures should comply with applicable local plumbing and building codes.

INSTALLATION BY A PROFESSIONAL, LICENSED PLUMBER OR CONTRACTOR IS HIGHLY RECOMMENDED.

**USER MANUAL**  
**AXENT.ONE C PLUS**

Smartphone App	3
Safety	4
Introduction	7
Multi-function Dial	9
Remote Control	18
Maintenance	28
Troubleshooting	31
Technical Data	35
Guarantee	36

# SMARTPHONE APP

## CONNECT YOUR AXENT INTELLIGENT TOILET WITH OUR APP

---

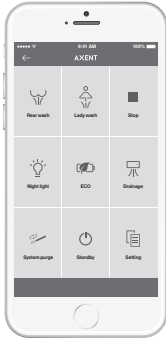

The Axent Remote App can be used as an individualized remote control with the Axent One C Plus.



[www.axentbath.us](http://www.axentbath.us) » Downloads

# SAFETY

## SAFETY SYMBOLS

---

The following symbols in the manual will highlight hazardous situations and their severities.



**DANGER!**

High Risk, Lethal Hazards, Severe Injuries



**WARNING!**

Medium Risk, Severe Injuries



**CAUTION!**

Low Risk, Minor Injuries



**NOTE!**

Damage to Property

## NORMAL USAGE

---

The intelligent toilet's spray arm attachment should only be used for the rear wash and front wash cleaning functions. The product may also be used as a normal toilet seat. This product is meant for indoors usage only.

Any other usage will not be deemed as normal usage. AXENT undertakes no liability for abnormal usage.

AXENT is not liable or responsible for damage to other electronics connected to the same power line while the intelligent toilet is in use.

## IMPORTANT SAFEGUARDS

---

**READ ALL INSTRUCTIONS BEFORE USING**

## SAVE THESE INSTRUCTIONS

---

A copy of the instructions can also be downloaded from <https://axentbath.us>.

When using electrical products, especially when children are present, basic safety precautions should always be taken, including the following:



**DANGER!**

### To reduce the risk of electrocution

---

**Do not reach for any electrical components of the intelligent seat that have fallen into water. Unplug toilet immediately.**

Unplug product if not in use for extended periods of time.

Do not use while wet after bathing.

Do not place or store product where it can fall or be pulled into a tub or sink.

Do not place or submerge the intelligent toilet or its components into water or other liquids.

# SAFETY



## WARNING!

### To reduce the risk of burns, electrocution, fire, or injury to persons

Children or disabled persons may require supervision during use.

Use this product only for its intended use as described in this manual. Do not use attachments not authorized by the manufacturer.

Never operate this product if it has a damaged cord or plug, if it is not working properly, if it has been dropped or damaged, or dropped into water. Return the product to a service center for examination and repair.

## SAFETY INSTRUCTIONS

Carefully read and observe the following safety instructions!

### Information for the user

Children or persons with limited physical/mental capabilities may require supervision or proper instructions/guidance prior to or during use. Ensure that children cannot play with intelligent toilet.

### Avoid malfunctions and damage to the product as a result of improper use

If intelligent toilet is moved from a cold location to a warm location, condensation may form. Leave the unit switched off for a few hours.

Do not install the intelligent toilet in rooms where the temperature will be less than 4 °C (39 °F).

Do not place open flames, candles, cigarettes, or similar objects on or by the toilet.

Do not reuse old hoses or water lines. Please use new water lines when installing.

Do not install the intelligent toilet next to items that would potentially expose the toilet to a large amount of water.

Do not climb on or stand on the product.

Do not place any heavy objects on the lid.

Do not open or close the lid or seat with force.

Do not deliberately soil, spray or block the spray arm.

### Repairs must only be carried out by a person with the necessary expertise

Do not carry out modifications, tamper with, install additional equipment, or attempt to repair the intelligent toilet.

Improperly performed repairs can lead to accidents, injuries, or damage to the product.

Keep the cord away from heated surfaces.

Do not block the air vents on this product. Do not place the toilet on or by objects such as long window curtains that could potentially obstruct the air vents during normal usage. Keep air vents free of lint, hair, and other debris.

Never use while sleepy or drowsy.

Never drop or insert any object into any openings or hoses.

Do not use outdoors or operate where aerosol (spray) products are being used or where oxygen is being administered.

Connect this product to a properly grounded outlet only. See Section « GROUNDING INSTRUCTIONS » on page 6.

Unplug this product before filling water. Fill (reservoir) with water only unless otherwise specified by manufacturer. Do not overfill.

### Only use the device when it is fully functional

Make sure the power cable is not damaged before use. Do not allow the power cable to be severely pinched, bent, or kinked.

Keep the power cable away from hot surfaces and sharp edges.

Do not handle the power cord or plug with wet hands.

Do not use the product if it is not working properly. In case of malfunction, disconnect the power immediately. Close the water cut-off valve to interrupt the water supply. Contact your installer.

### Information on the use of batteries

Keep batteries out of the reach of small children. Batteries can be life-threatening if swallowed. If a battery has been swallowed, seek medical assistance immediately.

Do not attempt to recharge non-chargeable batteries for use with unit.

Always remove empty batteries from the remote control immediately. They may leak and cause damage.

Do not insert new and old batteries together in the remote control.

Clean the battery and contacts before inserting the battery. Make sure the batteries are oriented properly.

Remove the batteries if the remote control will not be used for an extended period of time.

Do not expose the batteries to hot surfaces or direct sunlight to reduce the risk of battery leakage.

If battery acid has leaked, avoid contact with skin, eyes and mucous membranes. In case of contact with the acid, flush the affected areas with large amounts of clean water and seek medical assistance immediately.

# SAFETY

## GROUNDING INSTRUCTIONS

This product must be grounded when plugged in. The power cord on this product has a grounding plug and must be plugged into an outlet with a properly grounded grounding plug.



### DANGER!

**Improper use of grounding plug can result in a risk of electric shock**

For safety, the intelligent toilet should be plugged into a standard 3 prong GFCI outlet.

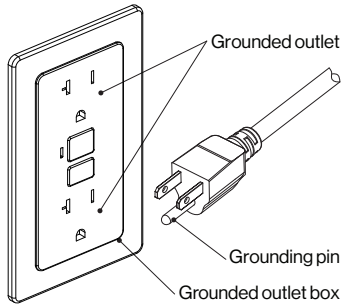

Wiring Diagram (NOT FOR INSPECTOR'S USE)

## FCC INSTRUCTIONS

Please note that changes or modifications not expressly approved by the party responsible for compliance could void the user's authority to operate the equipment.

Note: This equipment has been tested and found to comply with the limits for a Class B digital device, pursuant to part 15 of the FCC Rules. These limits are designed to provide reasonable protection against harmful interference in a residential installation. This equipment generates, uses and can radiate radio frequency energy and, if not installed and used in accordance with the instructions, may cause harmful interference to radio communications. However, there is no guarantee

that interference will not occur in a particular installation. If this equipment does cause harmful interference to radio or television reception, which can be determined by turning the equipment off and on, the user is encouraged to try to correct the interference by one or more of the following measures:

If repair or replacement of the power cord or plug is necessary, do not connect the grounding wire to either flat blade terminal.

This product is not to be used with extension cords.

This product is factory equipped with a specific electric cord and plug to permit proper connection. No adapters should be used with this product. Do not modify the power cord on the toilet. If the power cord will not fit the outlet, have the proper outlet installed by a qualified electrician. If the product must be reconnected for use on a different type of electric circuit, the reconnection should be made by qualified service personnel.

Please unplug unit immediately and contact for service if cord becomes damaged. Do not use a bidet seat with a damaged cord.



### NOTE!

Actual installation may differ slightly from the diagram.

that interference will not occur in a particular installation. If this equipment does cause harmful interference to radio or television reception, which can be determined by turning the equipment off and on, the user is encouraged to try to correct the interference by one or more of the following measures:

- Reorient or relocate the receiving antenna.
- Increase the separation between the equipment and receiver.
- Connect the equipment into an outlet on a circuit different from that to which the receiver is connected.
- Consult the dealer or an experienced radio/TV technician for help.



# INTRODUCTION

## OVERVIEW

E314-02

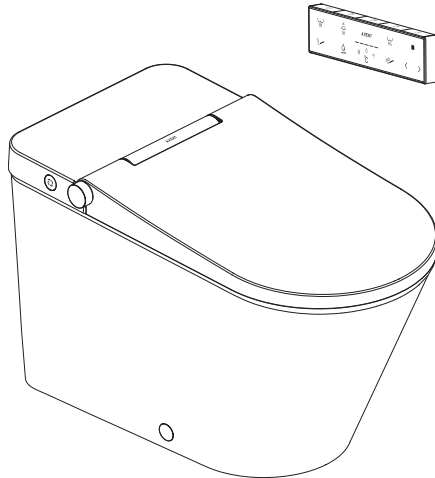

## REMOTE CONTROL

Activate the remote control by inserting the batteries.

For safety purposes, some functions, including the bidet, are only functional when the user is seated on the toilet seat.

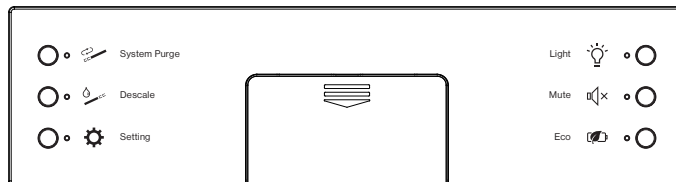
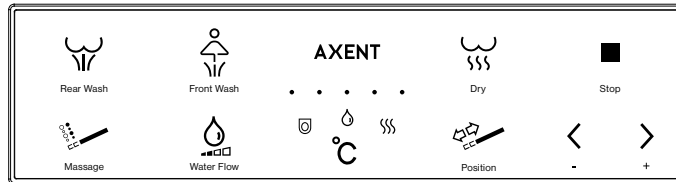
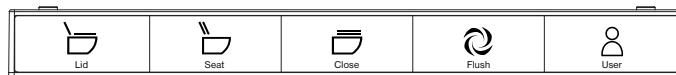

# INTRODUCTION

## MAIN

The intelligent toilet can be easily operated by the multi-functional dial and flush button.

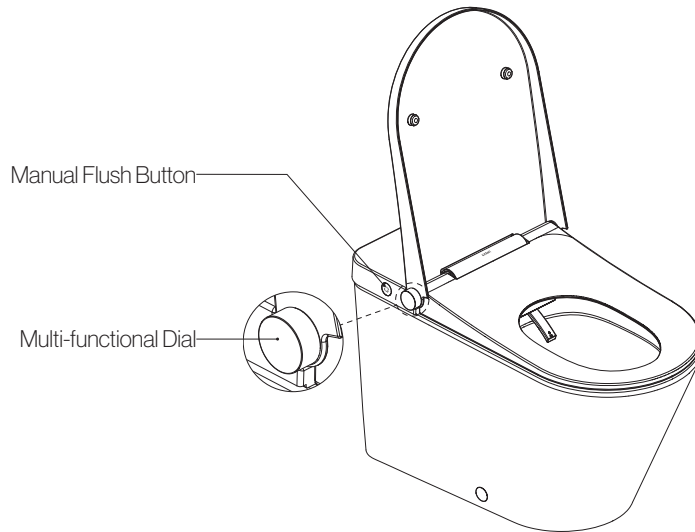

## MANUAL FLUSH

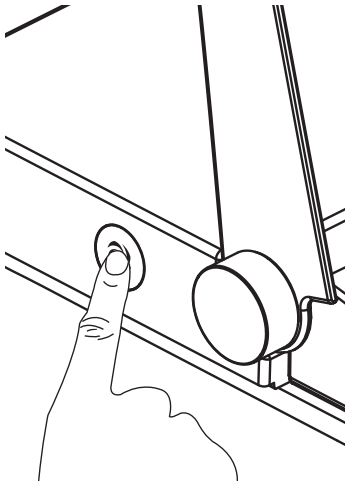

Press the Manual Flush Button located behind the multifunction knob to flush the toilet.

# MULTI-FUNCTION DIAL

## QUICK START

---

AXENT.ONE C PLUS offers a Quick Start function. Sit down on the toilet seat and push the dial. Rear Wash starts and will stop after another push on the button.



The spray arm is automatically cleaned with water before and after each washing procedure.



# MULTI-FUNCTION DIAL

## REGULAR USE

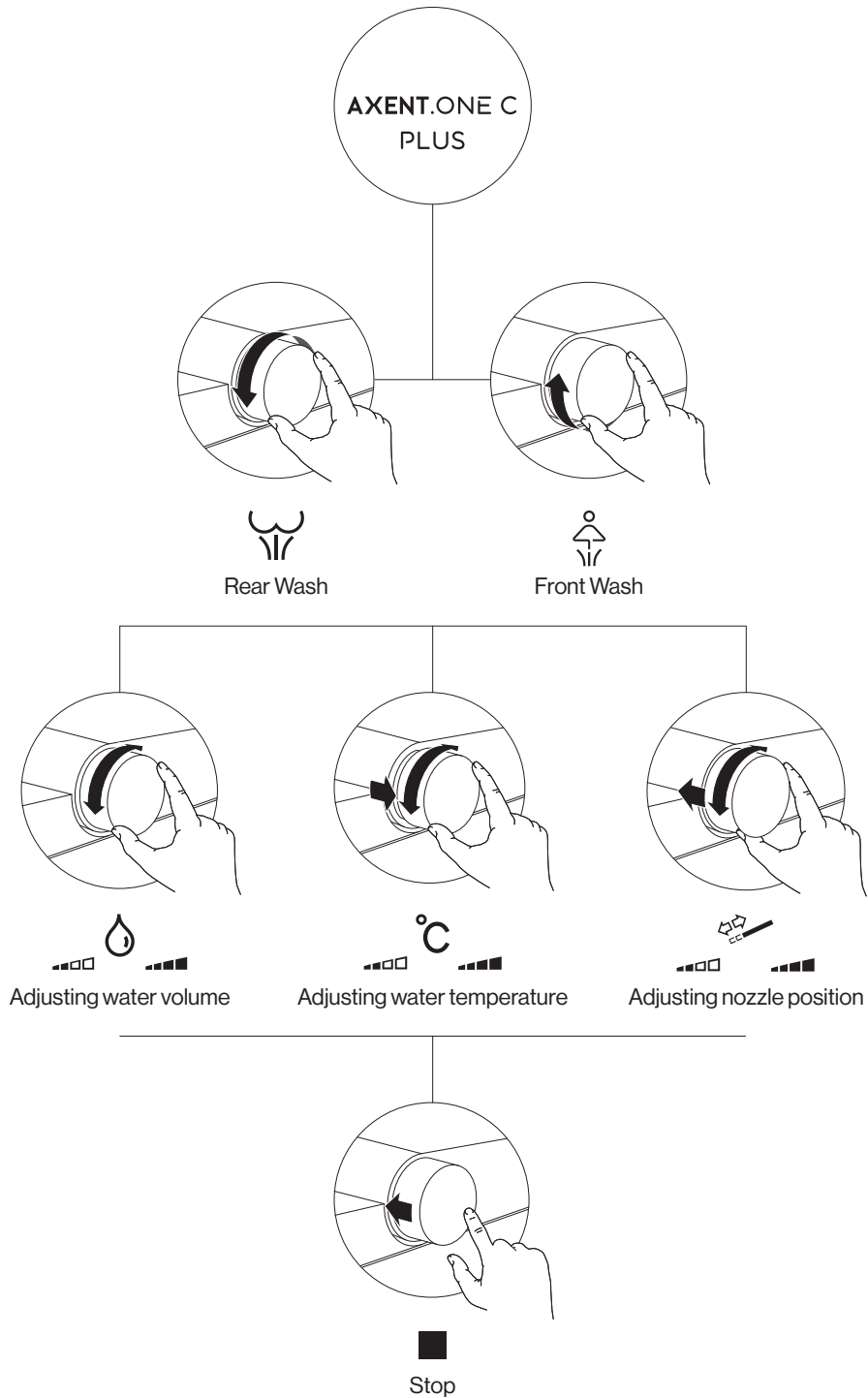

# MULTI-FUNCTION DIAL

## ADDITIONAL FEATURES

---

Additional settings and service functions may also be accessed with the multifunction dial. Access is done at two levels.

### LEVEL 1

- Mute ON / OFF
- Seat heating ON / OFF
- Self-cleaning function ON / OFF
- System purge

### LEVEL 2

- Night light ON / AUTO / OFF
- Deodorizer ON / OFF
- Auto dry
- Spray arm cleaning
- System reset

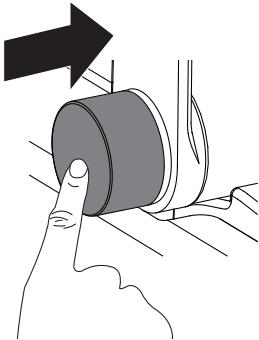

### ACTIVATING LEVEL 1

---

To activate LEVEL 1, press and hold the multifunction dial until the ambient light flashes slowly. The mode level 1 is activated when the ambient light continues to flash slowly.

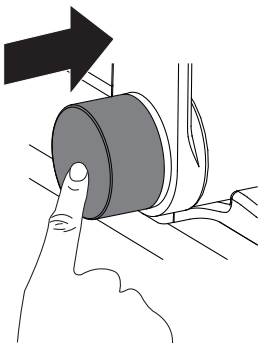

### DEACTIVATING LEVEL 1

---

When the multifunction dial is already at LEVEL 1, push the dial. The ambient light will stop flashing and you will hear one single «beep». The mode level 1 is deactivated.



If no functions are used within 3 minutes, LEVEL 1 will automatically deactivate.

# MULTI-FUNCTION DIAL

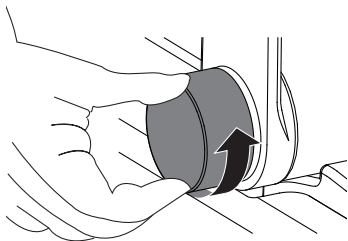

<b>LEVEL 1</b>	<b>MUTE</b>	<b>ON / OFF</b>
----------------	-------------	-----------------

Factory setting: Mute is OFF

When the multifunction dial is already at LEVEL 1 (the ambient light will flash slowly):

- Turn the multifunction dial counter clockwise.

No «beep»:	Mute is ON
Short «beep»:	Mute is OFF

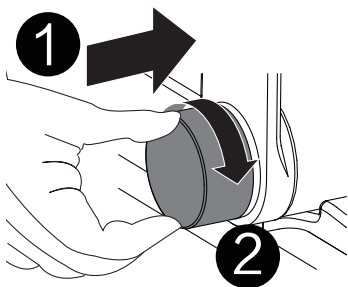

<b>LEVEL 1</b>	<b>SEAT HEATING</b>	<b>ON / OFF/AUTO</b>
----------------	---------------------	----------------------

Factory setting: Seat heating is ON

When the multifunction dial is already at LEVEL 1 (the ambient light will flash slowly):

- Press and hold the multifunction dial.
- Turn it clockwise.

Short «beep»:	Seat heating is AUTO
Long «beep»:	Seat heating is ON
Long «beep»:	Seat heating is OFF



# MULTI-FUNCTION DIAL

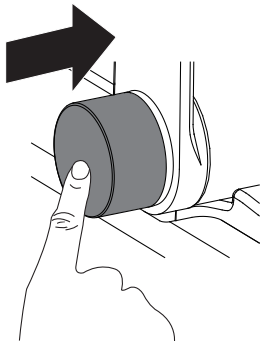

## ACTIVATE FUNCTIONS AT LEVEL 2

When the multifunction dial is already at LEVEL 1, press and hold the dial again until the ambient light flashes quickly. The mode level 2 is activated when the ambient light continues to flash quickly.

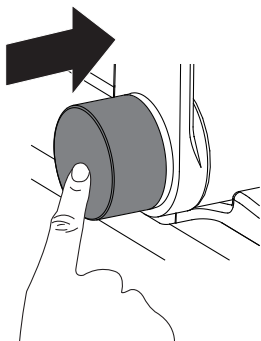

## DEACTIVATE FUNCTIONS AT LEVEL 2

When the multifunction dial is already at LEVEL 2, push the dial. The ambient light will stop flashing and you will hear one single «beep». The mode level 2 is deactivated.



If no functions are used within 3 minutes, LEVEL 2 will automatically deactivate.

LEVEL 2	NIGHT LIGHT	ON / OFF/AUTO
---------	-------------	---------------

Factory setting:		AUTO mode – The night light turn ON or OFF automatically according to ambient light levels.
------------------	--	---

When the multifunction dial is already at LEVEL 2 (the ambient light will flash quickly):

- Turn multifunction dial counter clockwise.

Short «beep»:	Night light function is AUTO
Long «beep»:	Night light function is ON
Long «beep»:	Night light function is OFF

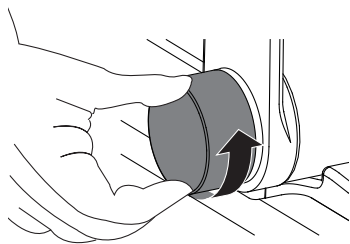



# MULTI-FUNCTION DIAL

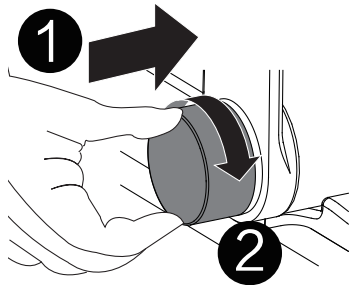

---

<b>LEVEL 2</b>	<b>DEODORIZER</b>	<b>ON / OFF</b>
----------------	-------------------	-----------------

---

Factory setting: Deodorizer is ON  
The deodorizer function is activated when a user is seated.

When the multifunction dial is already at LEVEL 2 (the ambient light will flash quickly):

- Press and hold the multifunction dial.
- Turn it clockwise.

Short «beep»: Deodorizer is ON  
Long «beep»: Deodorizer is OFF

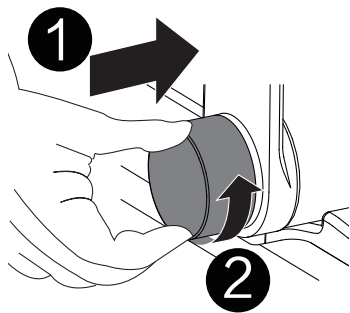

---

<b>LEVEL 2</b>	<b>AUTO DRY</b>	<b>ON / OFF</b>
----------------	-----------------	-----------------

---

Factory setting: Auto Dry is OFF  
The Auto Dry function is started when a user presses the multifunction dial during Rear or Front Wash.

When the multifunction dial is already at LEVEL 2 (the ambient light will flash quickly):

- Press and hold the multifunction dial.
- Turn it counter clockwise.

Short «beep»: Auto dry is ON  
Long «beep»: Auto dry is OFF

# MULTI-FUNCTION DIAL

## LEVEL 2 SPRAY ARM CLEANING

---

When the multifunction dial is already at LEVEL 2 (the ambient light will flash quickly):

- Turn the multifunction dial clockwise.

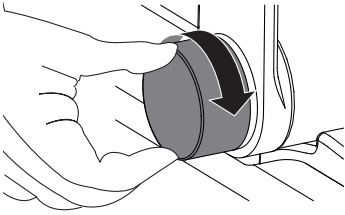

The spray arm will move out.

- Clean the spray arm with fabric or a soft bristled brush.
- Turn the multifunction dial clockwise again to retract the spray arm.

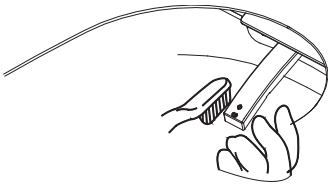

## LEVEL 2 SYSTEM RESET

---

When the multifunction dial is already at LEVEL 2 (the ambient light will flash quickly):

- Pull the multifunction dial.
- Turn it counter clockwise.

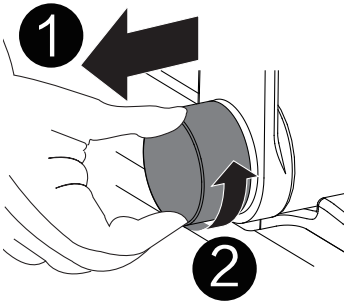

Short «beep»:

All values are reset to factory settings

# MULTI-FUNCTION DIAL

## STAND-BY MODE

---

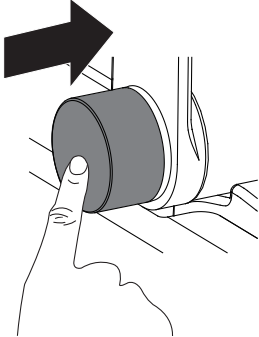

Press and hold the multifunction dial until the ambient light is off to activate Stand-By mode. In Stand-By mode, all functions of the toilet will deactivate until reactivated.

Gently tap the toilet seat lid to deactivate Stand-By mode.

## PAIRING TO DIAL

---

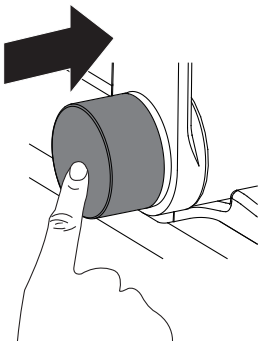

Cut off the power to the intelligent toilet, wait for 30 seconds, and then reapply power.

After three times short «beep», start pairing by pressing multifunction dial repeatedly until hearing three times long «beep» from the intelligent toilet, which means pairing successful.



Pairing has originally been done in the factory. It is only necessary after the seat or the dial has been replaced.

# REMOTE CONTROL

## REMOTE CONTROL

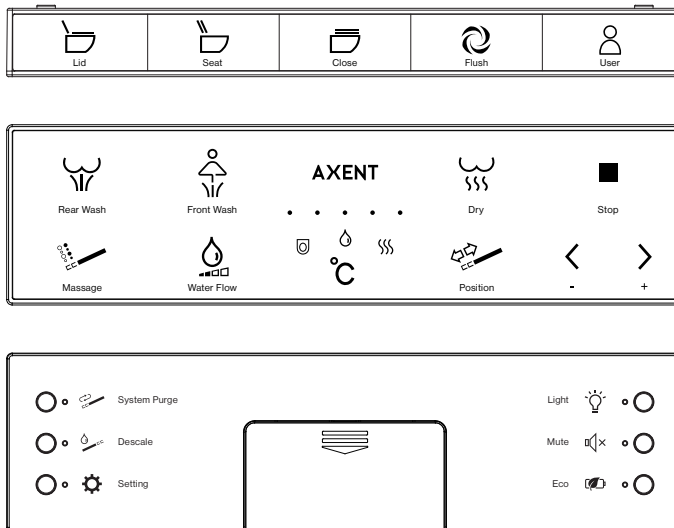

## REMOTE CONTROL ON/OFF/REPLACING BATTERIES

ON: Insert batteries.  
OFF: Remove batteries.  
Replacing batteries: When power is below 15%, the first and last of Level Indicator will blink on and off, indicating the battery needs to be replaced.



Do NOT insert new and old batteries together in the remote control.

## STAND-BY MODE REMOTE CONTROL

The remote control enters into the standby mode automatically and all indicator lights turn off when there is no activity for some time. Press « Stop » to exit stand-by mode.

# REMOTE CONTROL

## PAIRING

---

Cut off the power to the intelligent toilet, wait for 30 seconds, and then reapply power.



After three times «beep», start pairing by pressing « Stop » repeatedly until hearing three times long «beep» from the intelligent toilet, which means pairing successful.



Pairing has originally been done in the factory. It is only necessary after the remote control has been replaced.

## OPENING AND CLOSING THE SEAT AND LID

---



Press « Lid » when the unit is not in use to open the lid.

- When Auto Open is enabled and set to Lid, the lid will automatically open when someone approaches.



Press « Seat » when the unit is not in use to open the seat and lid.

- When Auto open is enabled and set to Seat, the lid and seat will automatically open when someone approaches.



Press « Close » when the unit is not in use to close the lid and seat.

- Lid and seat will be closed automatically 2 minutes after leaving.



The seat will only open automatically after being closed for more than 10 seconds.

Please do not put things on the lid or seat.

## FLUSH

---



Press « Flush » to start.

- After being seated for more than 5 seconds, the function will be started after a period of time defined by the Auto flush setting which defaults to 15 seconds.

# REMOTE CONTROL

## FRONT OF REMOTE CONTROL

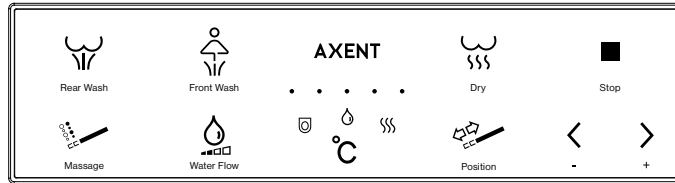

## REAR WASH



Rear Wash

Press « Rear Wash » after you are seated to start.



Stop

Press « Stop », to stop the Rear Wash early.  
If not stopped manually, the Rear Wash will stop automatically after 3 minutes.

## FRONT WASH



Front Wash

Press « Front Wash » after you are seated to start.



Stop

Press « Stop », to stop the Front Wash early.  
If not stopped manually, the Front Wash will stop automatically after 3 minutes.

## OSCILLATING AND PULSATING SHOWER



Massage

During Rear or Front Wash,

- Press « Massage » once to start Oscillating.
- Press « Massage » twice to start Pulsating.
- Press « Massage » three times to start Oscillating and Pulsating.

# REMOTE CONTROL

## WATER VOLUME

---



Water Volume

Press « Water Volume » during Rear or Front Wash to adjust the water volume.

The Level Indicator indicates the selected level.



Minus

Press « Minus » to reduce the water volume.



Plus

Press « Plus » to increase the water volume.

## SPRAY ARM POSITION

---



Position

Press « Position » during Rear or Front Wash to adjust the position of the spray arm.

The Level Indicator indicates the selected level.



Minus

Press « Minus » to move the Spray Arm backward.



Plus

Press « Plus » to move the Spray Arm forward.

## DRY

---



Dry

Press « Dry » after you are seated to activate the dryer.



Stop

Press « Stop », to stop the dryer early.

If not stopped manually, the dryer will stop automatically after 3 minutes.

# REMOTE CONTROL

## FRONT OF REMOTE CONTROL

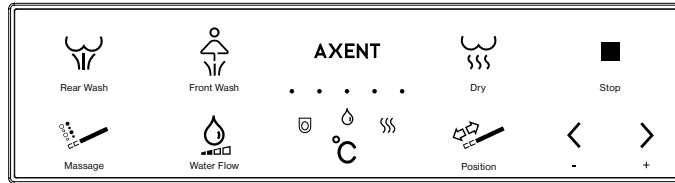

## TEMPERATURE ADJUSTMENT



Temp

To adjust the seat, water, or air dryer temperature, press « Temp » repeatedly until the respective icon lights up.



Seat Temp



Water Temp



Air Temp



Minus

Press « Minus » to reduce the temperature.



Plus

Press « Plus » to increase the temperature.



# REMOTE CONTROL

## TOP OF REMOTE CONTROL



## BACK OF REMOTE CONTROL

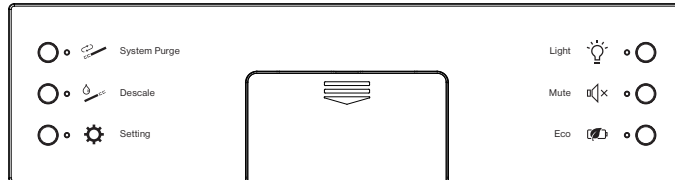

## NIGHT LIGHT SETTING



Factory setting: AUTO mode – The night light turn ON or OFF automatically according to ambient light levels.

Press « Light » to enter into the setting.  
Press « Light » to switch amount ON, OFF and AUTO.

The indicator indicates the selected option:

- AUTO The indicator blinks 3 times and turns on.
- ON The indicator light remains on.
- OFF The indicator blinks for one second and turns off.

## MUTE SETTING



Factory setting: Mute setting is OFF.

Press « Mute » to set the mute mode ON or OFF.

The indicator indicates the selected option:

- ON The indicator light remains on.
- OFF The indicator blinks for one second and turns off.

## ECO SETTING



Factory setting: Eco setting is OFF.

Press « Eco » to turn the function on or off.  
When the ECO function is turned on, the seat will be intelligently heated according to the user's usage habits.

The indicator indicates the selected option:

- ON The indicator light remains on.
- OFF The indicator blinks for one second and turns off.



# REMOTE CONTROL

## AUTO CLOSE SETTING

---



Setting

Factory setting: Auto Close function is ON.



Close

Press « Setting » at the same time « Close » to activate Auto Close.

Press « Close » repeatedly to enable or disable Auto.

The Level Indicator indicates the selected level:

- OFF One indicator on.
- ON Five indicators on.

## AUTO FLUSH SETTING

---



Setting

Factory setting: Auto Flush function is 15 seconds.



Flush

Press « Setting » at the same time « Flush » to activate Auto Flush Setting.

Press « Flush » repeatedly to toggle between OFF, 5 seconds, 10 seconds, 15 seconds, 20 seconds and 25 seconds.

The Level Indicator indicates the selected level:

- OFF All indicators off.
- 5 seconds One indicator on.
- 10 seconds Two indicators on.
- 15 seconds Three indicators on.
- 20 seconds Four indicators on.
- 25 seconds Five indicators on.

## DEODORIZE SETTING

---



Setting

Factory setting: Deodorize function is ON.



Mute

Press « Setting » at the same time « Mute » to turn the function on or off.

The indicator indicates the selected option:

- ON The indicator light remains on.
- OFF The indicator blinks for one second and turns off.

## USER PROFILE

---



User

Press « User » to switch between different user profiles. There are a total of 5 user profiles.

The Level Indicator indicates the selected user profile.

Functions will automatically revert to settings defined by the user.

Changes to the user's settings will be saved automatically when the user profile is active.

You will exit the user profile mode after activating the stand-by mode of the remote control for a moment.

# REMOTE CONTROL

## BACK OF REMOTE CONTROL

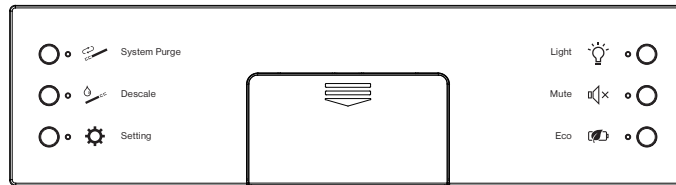

## SELF CLEANING SETTING



Setting

Factory setting: Self Cleaning function is ON.



Eco

Press « Setting » at the same time « Eco » to turn the function on or off.

When the Self Cleaning function is turned on, as soon as you sit down on the toilet seat, the spray arm will be cleaned with fresh water.

The indicator indicates the selected option:

- ON The indicator light remains on.
- OFF The indicator blinks for one second and turns off.



The system will always clean itself after use. This cannot be disabled.

## SYSTEM PURGE



System Purge

After a long period of inactivity, the water inside of the unit can be purged and replaced with fresh water.

Press « System Purge » to turn on function.

The system purge process will automatically stop after 90 seconds.

# REMOTE CONTROL

## SPRAY ARM CLEANING

---



Press « Descal » to extend the spray arm for cleaning.

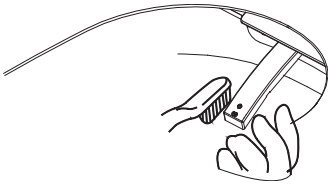

The spray arm will move out.

- Clean the spray arm with a fabric or a soft bristle brush.
- Press « Descal » again to retract the spray arm.



If no other functions are used, the spray arm will automatically retract after 3 minutes.

## RESET

---



Remove the batteries to turn off the remote control.



Press « Eco », « Setting » and insert batteries at the same time. The remote control will be restored to factory settings when turned on.



The reset function will reset the intelligent toilet and remote control to factory settings. All user profiles will be deleted.

# MAINTENANCE

## DURING VACATION

If this product will not be in use for an extended period of time, please perform the following in this order:

- Disconnect the electrical power.
- Shut off the water inlet valve.
- Press the Manual Flush button.

## WINTERIZATION

Please ensure water temperatures will not drop below 39 °F. Frost or frozen water will damage the system and may lead to leakage.

If the water or ambient temperature drops below 39 °F , please discontinue use of product. Additionally, if the intelligent toilet is moved from a cold location to a warm location, condensation may form. Leave the unit switched off for a few hours before use.

- Disconnect the electrical power.
- Shut off the water inlet valve.
- Disconnect the water inlet hose from the filter to drain out the water inside of the line.
- Press the Manual Flush button.



FAILURE TO DRAIN SYSTEM MAY RESULT IN DAMAGE TO SYSTEM AND LEAKAGE OR FLOODING. RELATED DAMAGE AND INCIDENTALS WILL NOT BE COVERED UNDER WARRANTY OR IN ANY OTHER MANNER BY AXENT.

## FILTER CLEANING

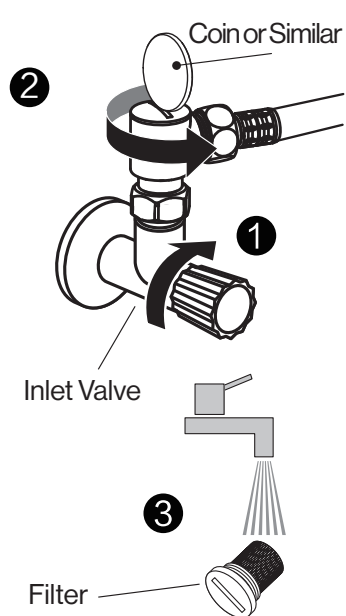

The filter screen will need to be cleaned frequently. If the unit does not fill up properly, starts to lose pressure, or does not function normally, please clean the filter first.



DO NOT use the product without the filter. Otherwise the product may not be warranty. The water inlet valve must be shut off during the entire filter cleaning process. The filter may be reinserted in reverse after cleaning.

# MAINTENANCE

## CLEANING INSTRUCTIONS SEAT, LID AND BACK COVER

---

Use a mild soap solution to clean the seat. Please take care that the seat and hinges are not left damp. Dry off any residual water or cleaning agent with a soft cloth. Ensure that the seat and seat hinges do not come in contact with abrasive, corrosive, or chlorine-based cleaners, as these may cause damage or lead to flash rust. When cleaning the bowl, make sure that the seat and cover are kept in an upright position until all cleaning agent has been flushed away.



### **DISCONNECT THE POWER BEFORE CLEANING THE PRODUCT.**

**Do NOT use any scouring equipment or tools (ex: scouring pad) or any aggressive cleaning agents for cleaning.**

## CLEANING CERAMIC APPLIANCES

---

Do not use harsh or abrasive cleaning substances such as abrasive cleansers, scouring powder or drain cleaner on your ceramic surfaces. Also avoid using steam cleaners and hard, abrasive sponges. Please do not pour or dispose of hair coloring products into the toilet as this can reduce the effectiveness of the AXENT Easy Clean coating.

By following these maintenance guidelines, AXENT Easy Clean should remain effective for many years. AXENT highly recommends the use of acidic cleaners with a pH value between 1 and 4. Cleaners with a pH value in the neutral range (5 to 8) are not always suitable. We strongly advise against using either weak or strong alkaline cleaners, i.e. substances with pH values from 9 to 12.

## SUITABLE CLEANING DETERGENTS

---

- Mild bathroom or all-purpose cleaner
- Mild detergents
- Normal toilet brushes
- Soft sponges
- Microfiber cloth

## REMOVING THE TOILET SEAT AND LID

---



The toilet seat and lid can be removed, cleaned and remounted quickly and easily when heavily soiled.

1. Disconnect electrical power.
2. Lift up on the toilet seat and lid.
3. Remove the toilet seat and lid by lifting up vertically so the pins come out of the mounting holes.
4. Clean the toilet seat and lid.
5. Insert the toilet seat and lid vertically from the top down into the mounting holes. Make sure the pins are aligned properly.
6. Let the toilet seat and lid glide down.
7. Connect the electrical power.

# MAINTENANCE

## UNINSTALLING AND INSTALLING THE LID AND SEAT

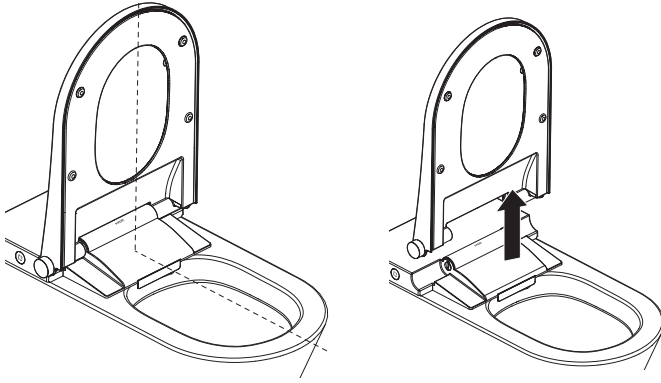

## INSTALLING THE LID AND SEAT

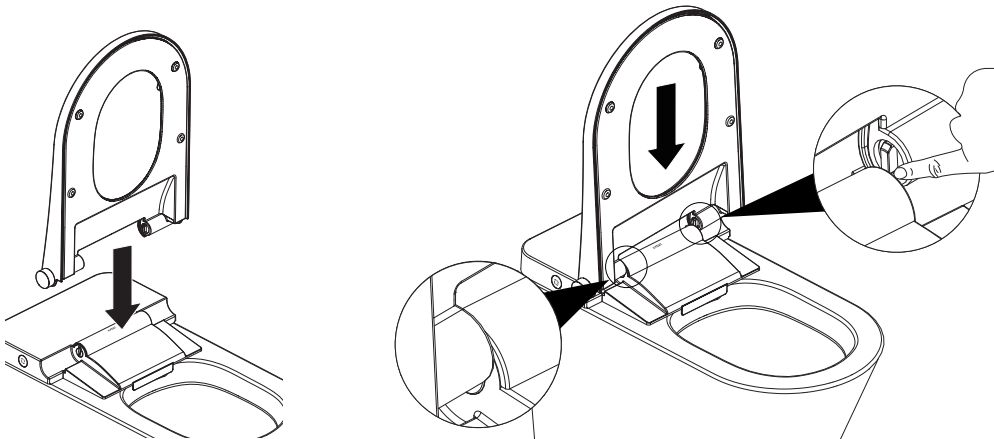

## CLEANING HINGES

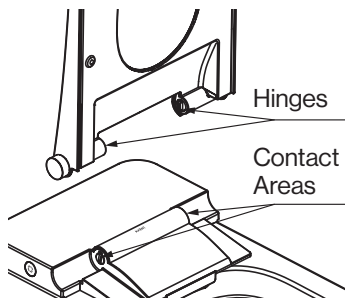

The hinges and contact areas on the toilet seat and cover must be cleaned regularly. This ensures the proper function of the shower toilet.

- Clean up the contact areas on the cover with moistened cloth.
- Clean up the hinges bolts on toilet seat with a damp cloth.



Do NOT use any cleaning agents for cleaning.



# TROUBLESHOOTING



## **ELECTRICAL SHOCK! FATAL DANGER!**

Never open the unit in order to repair it yourself. Never modify the device or add any additional modules. The AXENT intelligent toilet carries live power when plugged in and opening it exposes those present to fatal danger!  
Warranty and liability claims as a result of wrong handling are specifically excluded.

## **RESTART**

Perform a reset, if needed. Unplug the AXENT intelligent toilet, wait for 30 seconds, then reconnect to power.

## **FREQUENTLY ASKED QUESTIONS**

**IN CASE OF MINOR MALFUNCTIONS, PLEASE REFER TO THE FOLLOWING TABLE. IF THE BELOW SOLUTIONS DO NOT RESOLVE THE ISSUE, PLEASE CONTACT CUSTOMER SUPPORT FOR FURTHER EXAMINATION AND REPAIR.**

<b>Malfunction</b>	<b>Cause</b>	<b>Solution</b>	<b>Page</b>
No function	Product in Stand-by mode	Gently tap the toilet seat lid to deactivate Stand-by mode.	17
Remote control does not work	Battery is low	Replace batteries.	/
Level Indicator blinks on and off	Battery is low	Replace batteries.	/
Remote control works but does not control toilet	Out of range	Please use the remote control within the inductive distance.	/
Spray arm move out too slowly	Self-cleaning	Please wait for self-cleaning to finish.	/
Low water volume	Water volume set too low	Increase water volume.	21
Low water temperature	Water temperature set too low	Increase water temperature.	22
Water stop suddenly	Leaving the seat during washing	Seated and restart the washing.	20
Spray arm extending without water spraying out	Seat does not sense person	Reconfirm position on seat.	20

# TROUBLESHOOTING

Malfunction	Cause	Solution	Page
Dryer does not work	Seat does not sense person	Reconfirm position on seat.	21
Low air temperature	Air temperature set too low	Increase air temperature.	22
Massage does not work	Can only be activated during the wash cycle	Restart massage during Front or Rear wash.	20
Low seat temperature	Seat temperature set too low	Increase seat temperature.	22
High seat temperature	Seat temperature set too high	Reduce seat temperature.	22
Low seat or water temperature upon initial use	Eco mode is on	Turn off Eco mode.	23
Seat will not open automatically	Auto open off	Set auto open as Lid or Seat.	24
	Lid not closed	Close lid.	19
	Less than 10 seconds after last Auto Close	Wait for 10 seconds after last Auto Close.	/
Auto close does not work	The user is still within the inductive distance	Leave the inductive distance or be static for 2 minutes	/
Deodorizer still runs after leaving seat	The deodorizer continues to run for 60 seconds after leaving the seat to increase effectiveness.	This is normal.	/
Deodorize does not work	Deodorize off	Turn on Deodorizer.	25
	Seat does not sense person	Reconfirm position on seat and proper installation of seat.	/
	During washing	Wait for washing to finish and Deodorize will start automatically.	/

# TROUBLESHOOTING

<b>Malfunction</b>	<b>Cause</b>	<b>Solution</b>	<b>Page</b>
Night light does not work	Night light in OFF mode	Switch night light setting to ON or AUTO mode.	23
Night light always on	Night light in ON mode	Switch night light setting to AUTO or OFF mode.	23
Spray arm retracts automatically during Descale process.	Wand will automatically retract after 3 minutes of inactivity.	Please restart the Descale process.	27
Water sprays out when Descale is activated	Sensing area on seat is covered	Deactivate sensor by removing object.	/
Continuous « beep »	Water temperature over normal usage limits	Disconnect the main plug and contact customer service.	/
Leakage protector trips frequently	Current leakage exceeds the normal value	Disconnect the main plug and contact customer service.	/

# TROUBLESHOOTING

## REPLACEMENT PARTS LIST

Individual instructions will be included with applicable replacement parts.

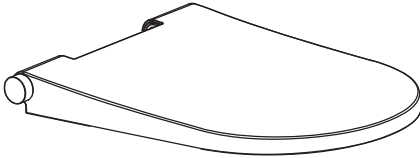

X1000000834  
Seat and Lid

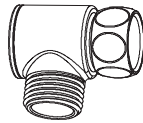

X1000000882  
Filter

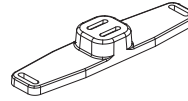

X10000001509  
flange support

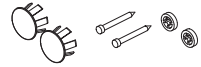

X10000000975  
Bowl Mounting Hardware / Plug

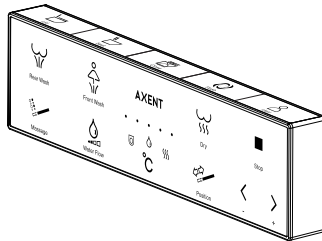

X10000000963  
Remote Control

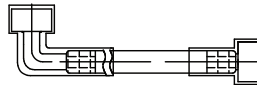

X10000000881  
Inlet Hose-set-2  
(Left: 15/16"-14UNS Right: 1/2"-14NPSM)

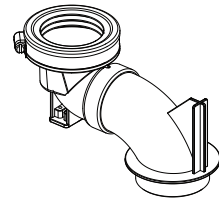

X10000001441  
Base Flange

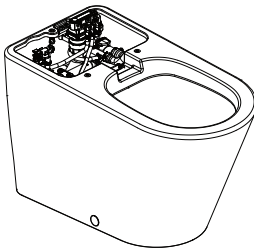

X10000001461  
Toilet Bowl

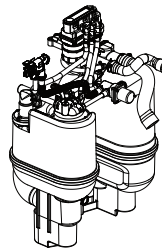

X10000001437  
Power Flush

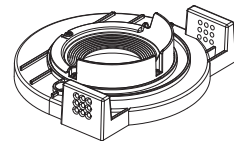

X10000001442  
12" Base Flange

# TECHNICAL DATA

---

Nominal voltage	120 V~, 60 Hz
Power consumption (max.)	1300 W
Protection degree	IPX4
Cable length	1.1 m (43 <sup>3</sup> / <sub>16</sub> inches)

---

Recommended Pressure Range	0.14 - 0.75 MPa ( 20 - 108 psi)
Ambient Temperature Range	4 - 40 °C ( +39 to +104 °F)
Water Temperature Range	4 - 35 °C ( +39 to +95 °F)
Product Weight	42 kg ( 93lbs)
Product Dimension ( L × B × H)	725 × 403 × 500 mm ( 28 <sup>1</sup> / <sub>2</sub> × 15 <sup>7</sup> / <sub>8</sub> × 19 <sup>3</sup> / <sub>8</sub> inches)
Maximum Load (Seat and Lid)	150 kg ( 330 lbs)

---

Max. flow rate Rear Wash	650 ml/min ( 1 <sup>1</sup> / <sub>16</sub> gal/min)	5 levels
Max. flow rate Front Wash	650 ml/min ( 1 <sup>1</sup> / <sub>16</sub> gal/min)	5 levels
Spray arm position		5 levels
Water temperature	31 - 39 °C ( +88 to +102 °F )	5 levels
Air dryer temperature	30 - 46 °C ( +86 to +115 °F )	5 levels
Seat temperature	29 - 37 °C ( +84 to +98 °F )	5 levels

---

## TECHNICAL SUPPORT

---

For any questions or any assistance with this product, please contact your dealer or call us at

1-800-769-4857

support@axentproducts.com

www.axentbath.us

## LEGAL DIRECTIONS

---

This manual contains important information on the intended use, correct operation and proper maintenance of the equipment. Knowledge of and compliance with the instructions of this manual are provided for both the safe use of the equipment and for the safety of its operation and maintenance. In this manual, not all kinds of applications and improper manipulations are considered. In addition, attention is drawn to the following: The content of these instructions is neither part of any previous or existing agreement, commitment or legal relationship, nor does it change from an existing agreement, commitment or legal relationship. Any commitment by AXENT results from the respective warranty. These include the complete and authoritative warranty obligation AXENT. The statements in this manual do not constitute an extension or a restriction of the claims under the warranty provisions. This manual is protected by copyright. Copies and / or translations into other languages may be made only with prior written approval of AXENT.

---

# GUARANTEE

## AXENT LIMITED WARRANTY

---

A three-year limited warranty applies to all AXENT products purchased on or after May 1, 2019. All products purchased on or before April 30, 2019 OR purchased for use in a commercial or hospitality setting on any date are backed by AXENT's one-year limited warranty. All spare parts purchased for use with Axent products are covered by a six (6) month limited warranty unless otherwise stated on the product.

1. AXENT warrants that its products are free from defects caused by defective material and faulty workmanship for a period of three-year from the date of purchase by the original purchaser. The limited warranty is to the original purchaser only. The limited warranty is not transferable to any third party. Proof of purchase showing both original ownership and purchase date is required for any warranty claim. The limited warranty applies to all products sold by authorized dealers in the United States and Canada and used within the United States and Canada. This warranty is limited to parts only and AXENT is not responsible for any installation labor charges, removal charges, installation, or other incidental or consequential cost.
2. AXENT's sole and maximum liability for breach of its warranties herein is limited to the obligation, at AXENT's sole discretion to repair, replace, or make appropriate adjustments to bring the product back to normal operating function. AXENT reserves the right to inspection of the product and verification of normal residential usage conditions during the warranty period before warranty claims are handled. In no event shall AXENT or Seller be liable to Buyer for consequential, incidental, economic, or special damages stemming from any breach of express or implied warranty.
3. Purchaser shall comply with the following procedures in connection with the warranty claim:
  - AXENT is notified in writing by Purchaser within thirty (30) days after discovery of defects;
  - Purchaser obtains a Return Authorization from AXENT prior to returning any defective product to AXENT;
  - The defective products are returned to AXENT, all shipping charges prepaid by Purchaser (provided however, that if upon examination by AXENT, it determines that the products are entitled to warranty, then AXENT shall be responsible for shipping charge to and from AXENT's facility).
  - The defective products are received by AXENT for adjustment no later than fifteen (15) days following the last day of the warranty period; and
  - AXENT's examination of such goods shall disclose that such defects or failures have not been caused by misuse, abuse, neglect, improper installation or application, repair, alteration, damage by rain, fire or casualty or by accident or negligence in use, storage, transportation or handling.
4. This warranty does not apply to the following items:
  - Damage or loss sustained in a fire, earthquake, storm or any natural disaster etc...
  - Damage or loss resulting from any unreasonable use, misuse, abuse, negligence or improper care, improper cleaning or maintaining of the product.
  - Damage or loss as a result of the use of in-tank toilet cleaners.
  - Damage or loss resulting from any sediments or foreign matter contained in the water system.
  - Damage or loss from improper installation, harsh environment, improper removal and water pressure in excess of 80PSI.
  - Damage or loss resulting from electrical surges, lightning strikes or other acts which are not considered normal or the fault of AXENT.
  - Damage or loss resulting from normal wear and tear, such as gloss reduction or dulling, scratching or fading over time due to normal use, cleaning practices, water or atmospheric conditions including but not limited to: bleach, alkali, acid cleaners, dry powdered cleaners or any other abrasive cleaning agents or abrasive cleaning tools or aids.
  - The use of any product in a manner outside of the product instructions / owner's manuals.
  - AXENT shall not be liable for any failure caused by chloramines in the public treated waters or cleaners containing chlorine (calcium hypochlorite). Please note that use of high concentrate chlorine or chlorine related products can damage fittings. This damage can cause leakage resulting in property damage.
5. AXENT'S OBLIGATION TO HONOR THESE WARRANTIES IS CONTINGENT UPON AXENT'S RECEIPT OF PAYMENT IN FULL FOR THE GOODS ENTITLED TO THIS WARRANTY. AXENT DISCLAIMS ALL OTHER WARRANTIES, EXPRESS, IMPLIED, OR STATUTORY, INCLUDING, WITHOUT LIMITATION, THE IMPLIED WARRANTIES OF MERCHANTABILITY AND FITNESS FOR A PARTICULAR PURPOSE. SELLER HAS NOT AUTHORIZED ANYONE TO MAKE ANY REPRESENTATION OR WARRANTY OTHER THAN AS PROVIDED ABOVE. THE FOREGOING STATES THE ENTIRE WARRANTY LIABILITY OF SELLER.

To obtain warranty service, contact AXENT's service team through your dealer or plumbing contractor, or via the points of contact below:

**Mailing Address:** Attn. Customer Service Department 3 Musick, Irvine, CA 92618

**E-mail:** [Support@axentproducts.com](mailto:Support@axentproducts.com)

**Phone:** 1-800-769-4857



Place serial number sticker  
here for reference:

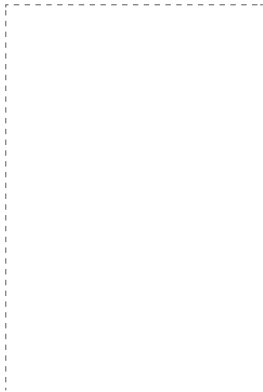

**AXENT Corporation Ltd.**

[www.axentbath.us](http://www.axentbath.us)  
[support@axentproducts.com](mailto:support@axentproducts.com)  
1-800-769-4857