

EASY TO RACE!

VELOCITY

RADIO-CONTROLLED HIGH-SPEED RACING BOAT

USER MANUAL



FOR MORE INFORMATION

Visit us online at force1rc.com for product information, replacement parts, and tutorials.

CONTENTS

Important Statement & Safety Warnings	3
Important Safety Notice for RC Boat Battery	4
Li-Ion Battery Care Instructions	5
Charging Instructions for Boat Battery	6
Box Contents & Boat Overview	7
Transmitter Overview & LCD Overview	8
Transmitter Battery Installation	9
Boat Battery Installation	10
Maintenance and Propeller Installation	11
Spindle Tube Lubrication	12
Pairing Boat with Transmitter	13
Left Hand Basic Operation Controls	14
Left Hand Trim Adjustments	15
Right Hand Basic Operation Controls	16
Right Hand Trim Adjustments	17
Spare Parts	18
FCC Information & Warning	19

IMPORTANT STATEMENT

Thank you for buying a Force1 RC boat. **Please read this manual carefully before operating the RC Boat.** By reading this manual it is assumed you are accepting all content in this user manual when using this RC Boat.

- (1) This product is not a toy but a piece of complicated equipment. Parts should be installed and adjusted correctly to avoid accidents. The user must always operate in a safe manner. We undertake no liability for human injury or property damage caused by improper operation, as we have no control over setup, use and operation of this RC boat.
- (2) This product is suitable for people of the age of 14. Anyone younger than 18 must be supervised by an adult when operating.
- (3) The location that you use the RC Boat must be waters approved by your local government.

If you have any questions about use, operation, technical support, repair, after-sale service, etc., Please contact us at **support@force1rc.com**

***Please use only original Force1 spare parts and accessories. Force1 does not assume any responsibility for any accidents caused by using non-genuine parts and accessories.**

***Keep the packaging and user manual for future reference.**

SAFETY WARNINGS

Improper assembly, broken main boat, defective electronic equipment, or unskilled operation may cause unpredictable accidents such as boat and property damage or human injury.

Please pay special attention to the following safety procedures:

- (1) After operating the boat, **DO NOT RECHARGE BATTERY** until it has cooled down.
- (2) When operating the boat, observe the area. Do not operate boat near people or debris in the water, as collision could damage the boat and result in injuries.
- (3) This product contains small parts and are a choking hazard. Keep away from young children.
- (4) Please keep a safe distance from propeller to avoid injury. The high speed propeller can cause harm.
- (5) After operation, **DO NOT TOUCH MOTOR**. The motor heats up and can burn your skin.
- (6) Regularly check parts for damage. Replace any broken parts before operating.
- (7) This is a high-speed boat that requires adequate space to navigate. Use caution when operating in pools or near pool liners. Damage to person or property is the sole responsibility of the user.
- (8) This boat has a safety feature disabling the propeller from operating while not in the water. If there is water on the sensor, the propeller could potentially still spin. Keep fingers and hair away from the propeller at all times. When changing the propeller, turn the remote off, remove the boat battery, and make sure the unit is completely dry before proceeding.
- (9) Avoid salt water. Some water in the hull is normal after use.

IMPORTANT SAFETY NOTICE FOR RC BOAT BATTERY

- * Keep Li-Ion batteries away from children and animals.
- * Never use or charge a Li-Ion battery that has ballooned or swelled.
- * Never use or charge a Li-Ion battery that has been punctured or damaged.
- * After a crash, inspect the battery pack for signs of damage.
- * Never overcharge a Li-Ion battery.
- * Do not charge Li-Ion batteries near flammable materials or liquids.
- * Do not put the battery in a high temperature place or in direct sunlight. Reduce risks of fire or explosion by storing Li-Ion batteries inside a Li-Ion safe bag.
- * Do not put battery packs in pockets or bags where they can short circuit or can come into contact with sharp or metallic objects.
- * Do not attempt to disassemble or modify or repair the Li-Ion battery.
- * Do not use the battery to break or hit a hard surface.
- * Do not put the battery in water and keep it stored at room temperature in a dry place.
- * Do not leave the battery unsupervised while charging.
- * Make sure that there is no short circuit of the power wire.
- * Please use the recommended charger only. Do not charge on a gaming console. Only use your computer's USB port, power bank or phone wall charger to charge the battery.
- * To avoid trickle charging, always unplug the battery from the USB charger when storing or leaving unattended.
- * Check the charger's wire, plug, and surface regularly. Do not use a broken charger.
- * If you are going more than one week without using Li-Ion batteries it is best to keep them stored at a 50% charge.

LI-ION BATTERY CARE INSTRUCTIONS

Temperature:

- Heat is a known factor in battery fires. If a battery is pushed beyond 60°C/140°F during discharging or charging, problems could occur which may damage the cell.
- After use, you may find your batteries are warm or hot to the touch. Give the batteries a chance to cool down before recharging.

Storage:

- When storing LiPo / Li-Ion batteries for any length of time, they should ideally be stored at a temperature of between 5°C/40°F & 27°C/80°F.

Usage:

- Leave time between charging and using the battery.
- To extend the lifetime of the battery, plan to end operation with about 20% power remaining in the batteries (rather than completely draining them)
- If the battery is pushed beyond its limits, the battery could get hot and the performance will drop.
- When using the battery for a long time, the battery will increase in temperature. If it is sealed, the air inside will inflate rapidly causing further heating.

Charging:

- If you feel like the battery is not charging properly, try plugging it into another charger if one is available and see if the issue persists. If the charger is defective, you should discard it immediately and go to **Force1RC.com** to purchase a replacement.

You may also contact our support team at support@force1rc.com so we can arrange to ship you a replacement charger and/or batteries if within the warranty period.

WARNING:
DO NOT LEAVE BATTERY
CHARGING UNSUPERVISED

CHARGING INSTRUCTIONS FOR BOAT BATTERY

1. Plug the white battery cable into the charging cable.



2. Choose one of the methods as pictured below to connect with USB plug.

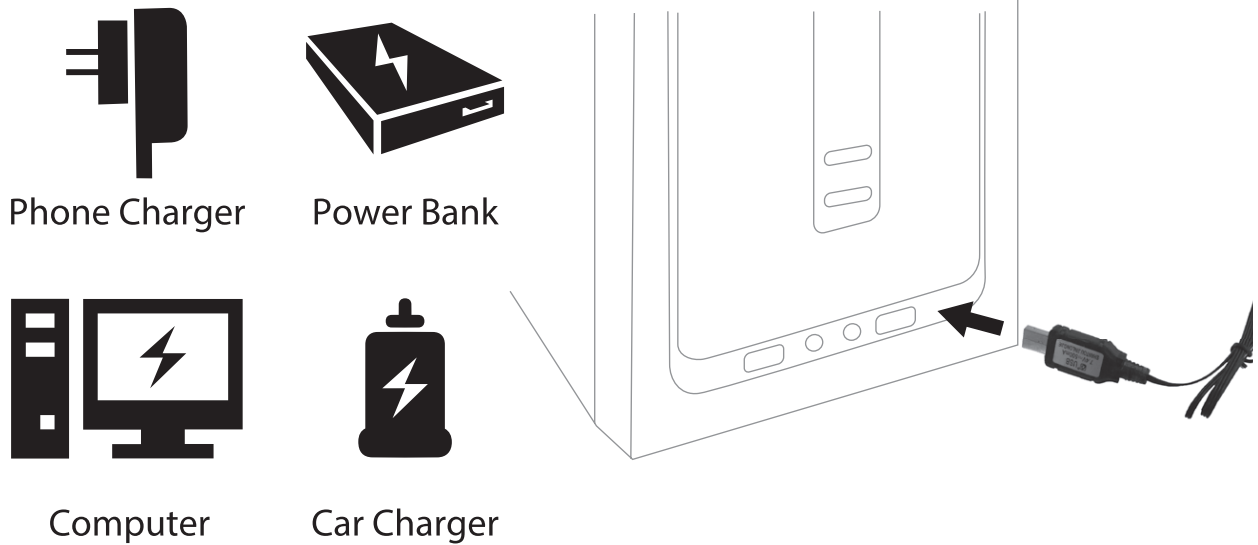

LI-ION BATTERY DISPOSAL & RECYCLING

Lithium-Ion batteries must not be placed with household trash.
Please contact local environmental or waste agency or
your nearest Li-Ion battery recycling center.



**WARNING:
DO NOT LEAVE
BATTERY CHARGING
UNSUPERVISED**

BOX CONTENTS



RC BOAT



TRANSMITTER



1100mAh 7.4v LiPo BATTERY

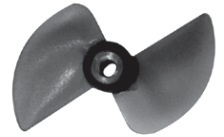

PROPELLER



USB CHARGER CABLE



NOSE GUARD



LUBRICATION OIL



RC TOOL



DISPLAY RACK WITH SCREWS

BOAT OVERVIEW

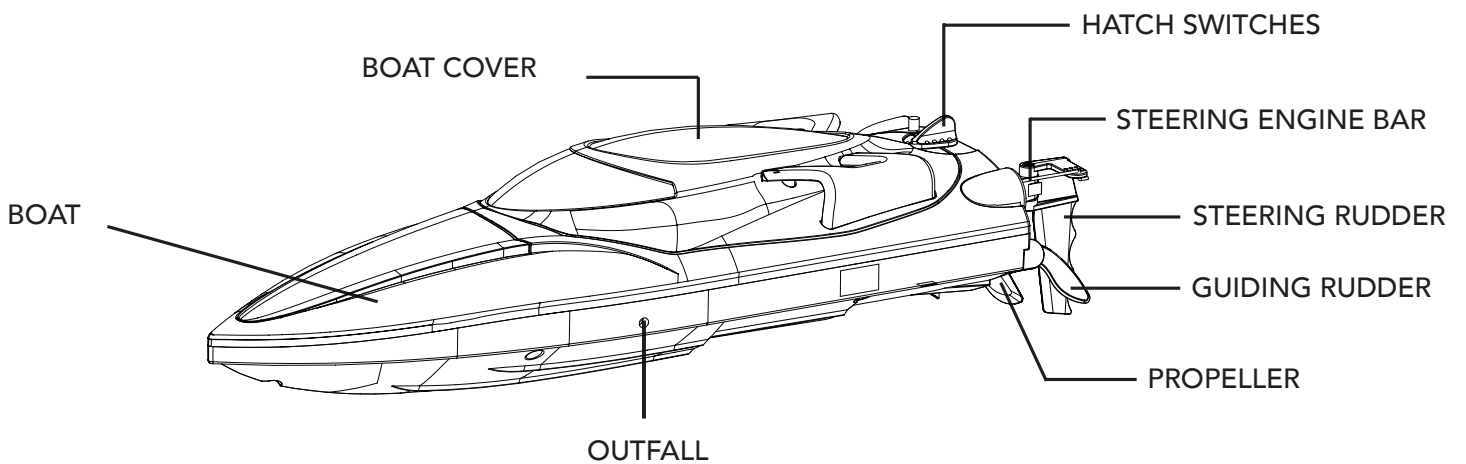

TRANSMITTER OVERVIEW

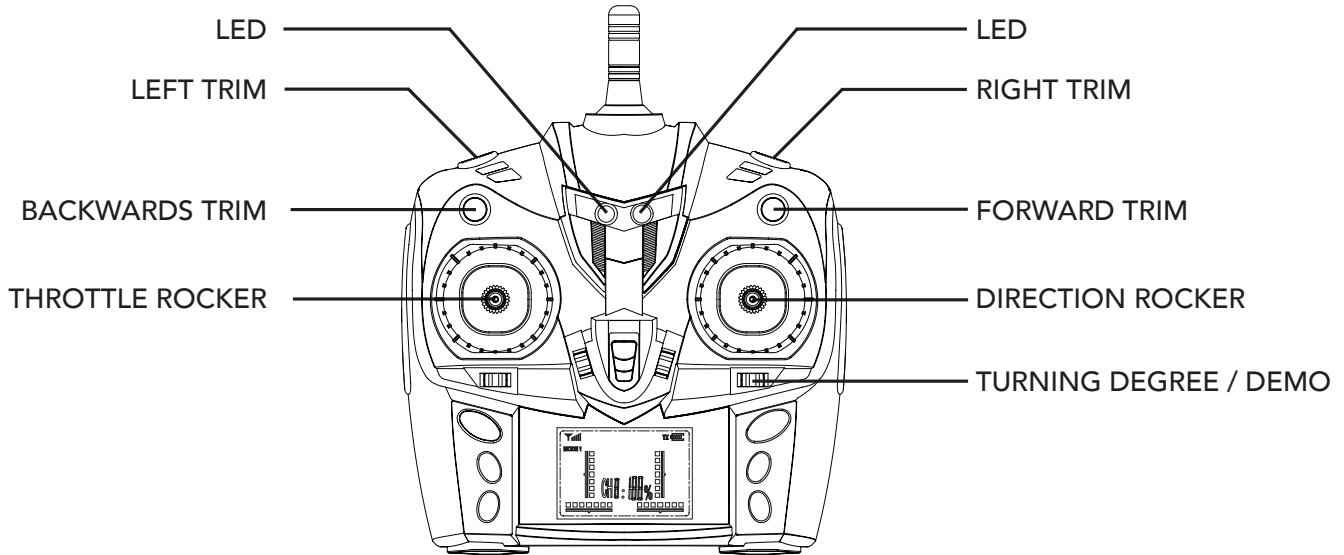

LCD OVERVIEW

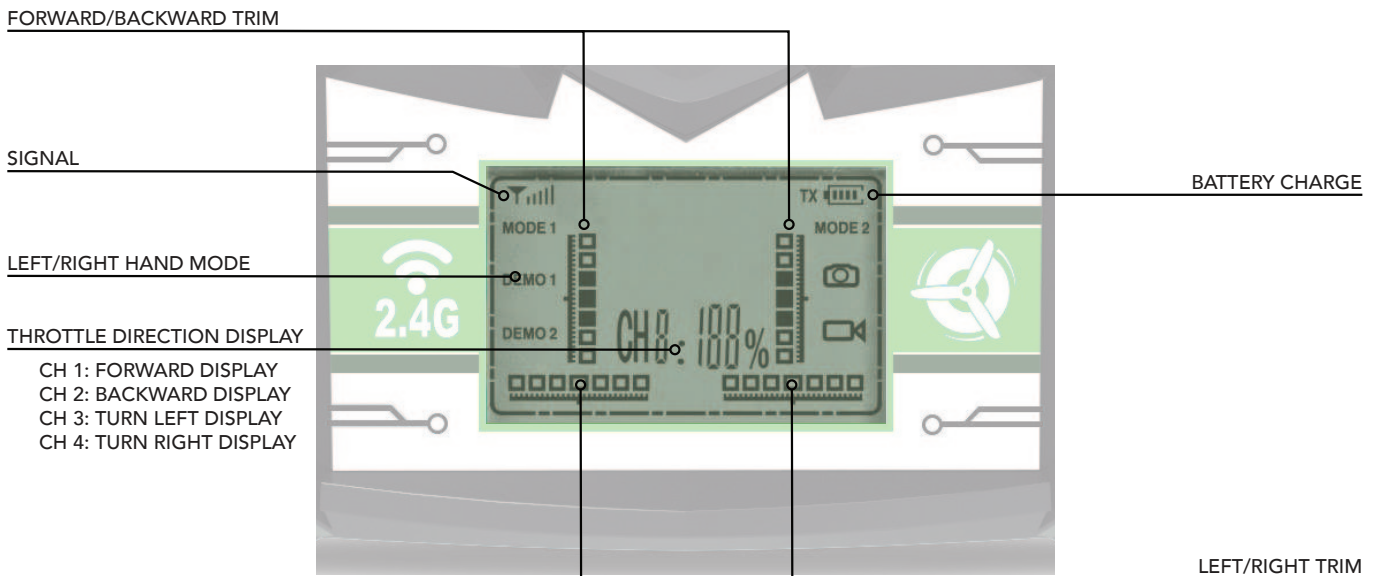

TRANSMITTER BATTERY INSTALLATION

Unscrew and open the battery cover on the back side of the transmitter and put 4 alkaline batteries (AA, not included) into the box in accordance with electrode instructions, as shown below.

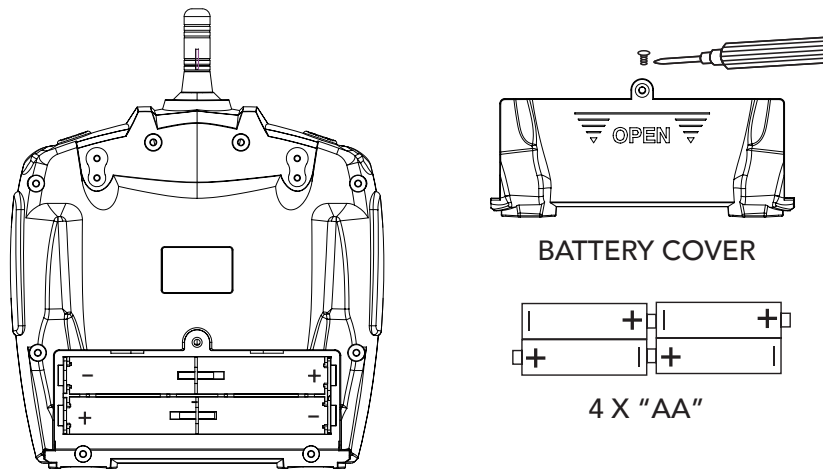

CAUTION:

- The transmitter needs 4 X AA batteries to work. Non rechargeable batteries are not to be charged.
- Insert batteries with correct polarity.
- Do not mix old and new batteries.
- Do not mix alkaline, standard (carbon-zinc), or rechargeable (nickel-cadmium) batteries.
- Rechargeable batteries are to be removed from the toy before being charged;
- Rechargeable batteries are only to be charged under adult supervision;
- Exhausted batteries are to be removed from the toy;
- The charging wire to be used with the product should be regularly examined for potential hazard, such as damage to the cable or cord, plug, enclosure of other parts and that in the event of such damage, the product must not be used unless or until that damage had been properly fixed.

BOAT BATTERY INSTALLATION

1. Turn the cabin switch either right or left to unlock. Remove the Cabin Cover (Picture 3).
2. Turn the 4 switches to unlock the Inner Hatch. Remove the Inner Hatch (Picture 4).
3. Put the Boat Battery into the battery holder of the hull (Picture 5).

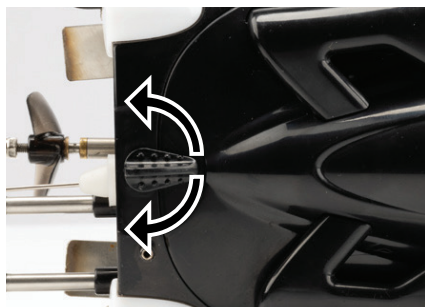

PICTURE 3

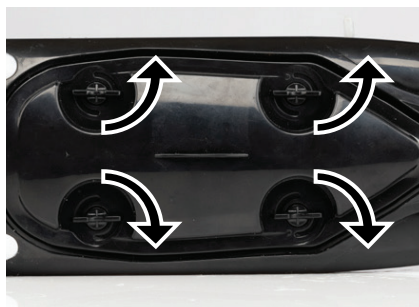

PICTURE 4

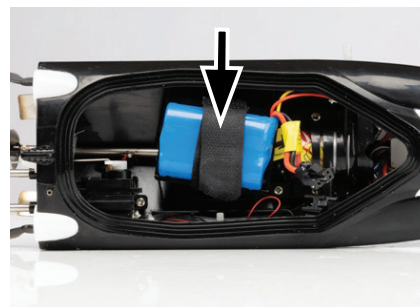

PICTURE 5

4. Connect the battery and power plug (Picture 6).
5. Insert the Inner Hatch at a diagonal angle to the boat body (Picture 7) and lock switches (Picture 8).
6. Insert the Cabin Cover at a diagonal angle to the boat body (Picture 9) and lock the cabin switch (Picture 10).

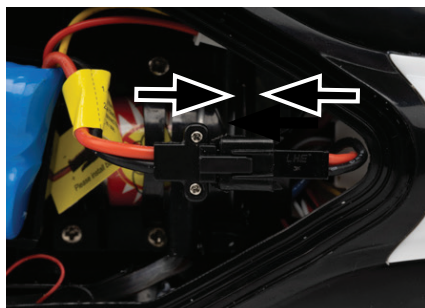

PICTURE 6

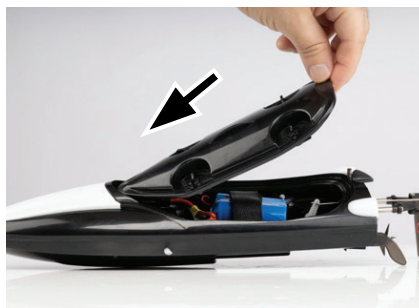

PICTURE 7

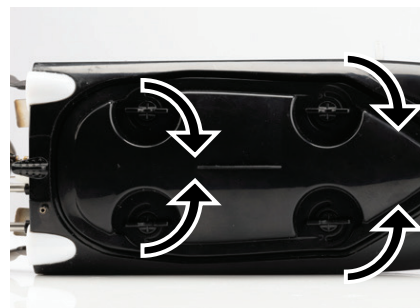

PICTURE 8



PICTURE 9



PICTURE 10

MAINTENANCE

1. After operation, please remove the battery.
2. After operation, dry the outside of the boat with a clean cloth.
3. If storing for extended periods of time, remove the transmitter battery to avoid battery leakage.
4. Keep the inside of the boat dry. After operation, dry the inside of the boat with a clean cloth (Picture 11). Using desiccant will ensure the boat is dry while not in use (Picture 12).



PICTURE 11



PICTURE 12

PROPELLER INSTALLATION

1. Remove both hull covers, disconnect and remove the battery, then unscrew the battery compartment (Picture 13).
2. Hold down the propeller or the spindle connector shaft and remove the bolt with the included wrench (Picture 14).
3. Hold down the spindle connector shaft and unscrew the propeller with your fingers (Picture 15).
4. Remove and replace the propeller, then reattach the bolt, and battery compartment to finish.



PICTURE 13



PICTURE 14

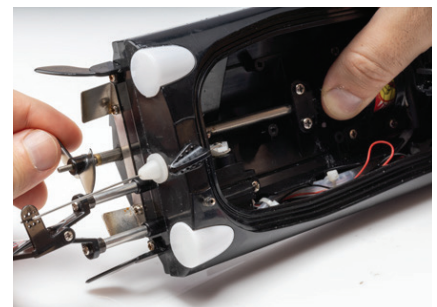

PICTURE 15

For more information on how to replace the propeller, check out our video by using the QR Code below:



SPINDLE TUBE WALL LUBRICATION

1. Unscrew the battery holder from the hull (Picture 16).
2. Unscrew the motor cover (Picture 17).
3. Unplug the motor (Picture 18) and unscrew the motor and the spindle cover (Picture 19).
4. Remove the rubber cooling hose from the hull (Picture 20).
5. Remove the motor from the hull and set aside from the boat (Picture 21).



PICTURE 16



PICTURE 17



PICTURE 18

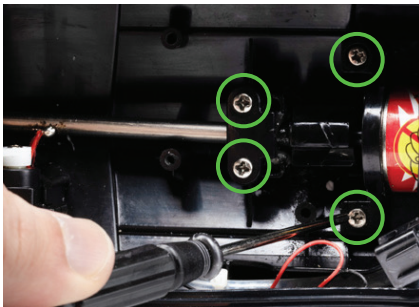

PICTURE 19



PICTURE 20



PICTURE 21

6. Hold the propeller in place and unscrew the bolt on the spindle with the included wrench (Picture 22).
7. Hold down the spindle connector shaft (Picture 23), unscrew the propeller, and remove it (Picture 24).
8. Pull the spindle out and apply a moderate amount of lubrication to the spindle (Picture 25).



PICTURE 22

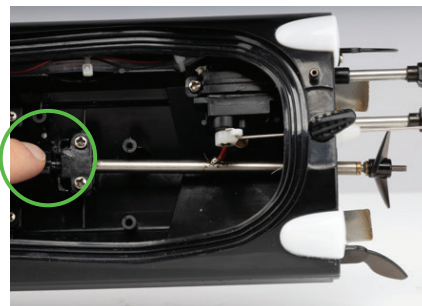

PICTURE 23



PICTURE 24

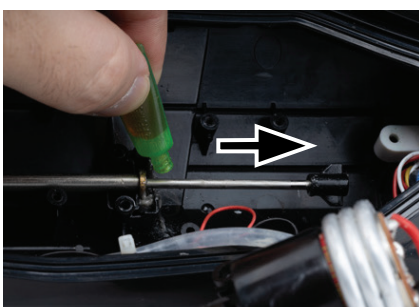

PICTURE 25

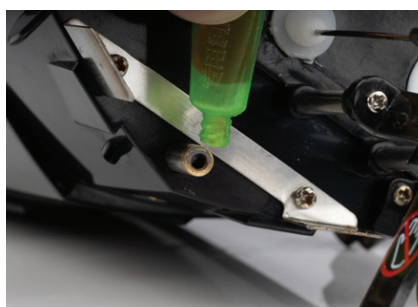

PICTURE 26



PICTURE 27

9. Apply lubrication to the spindle tube from the tail end as well (Picture 26). Push and rotate the spindle in and out of the tube in order to evenly distribute lubrication throughout the tube.
10. When finished, replace the motor into the hull and pull the rubber cooling hose into the boat body (Picture 27).
11. Screw the spindle cover (1), motor (2) and motor cover (3) back into place, reconnect the motor wire, then tuck the spare wiring into the side compartment (Picture 28).
12. Hold down the spindle connector shaft and screw the propeller back in (Picture 29).
12. Continue holding down the spindle connector shaft or propeller and use the included wrench to reconnect the bolt (Picture 30).

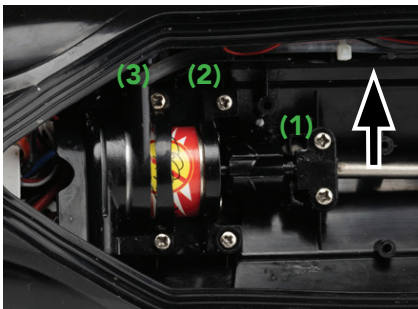

PICTURE 28

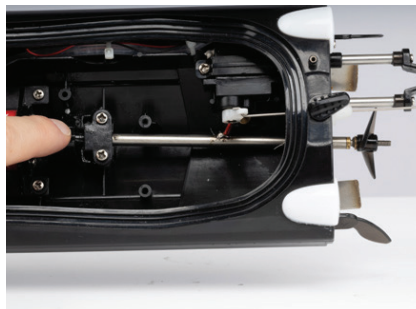

PICTURE 29



PICTURE 30

PAIRING BOAT WITH TRANSMITTER

1. Put the RC boat into the water.
2. Turn on the transmitter. The transmitter LED indicator will flash and make a beep sound.
3. The transmitter will make three beep sounds and the LED indicator will be solid, meaning it has paired.

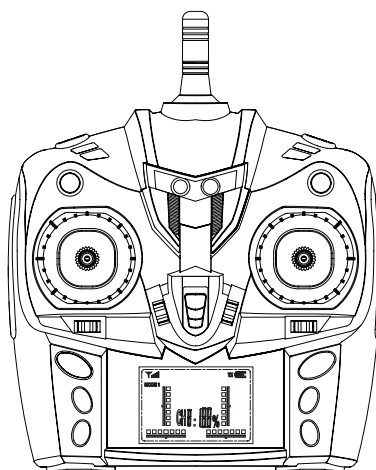

MODE 1 OPERATION CONTROLS

MOVE FORWARD OR BACKWARD

Push the **THROTTLE STICK** up and the boat moves forward. Pull the **THROTTLE STICK** down and the boat moves backward.

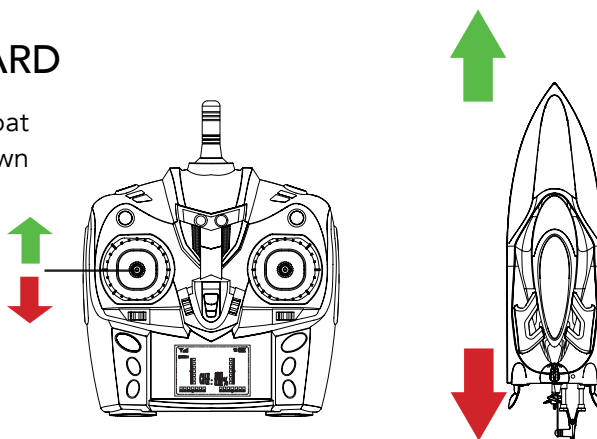

TURN LEFT OR RIGHT

While pushing the **THROTTLE STICK** forward, pulling the left **DIRECTION STICK** left will make the boat turn to the left. Pulling the **DIRECTION STICK** right will make the boat turn to the right.

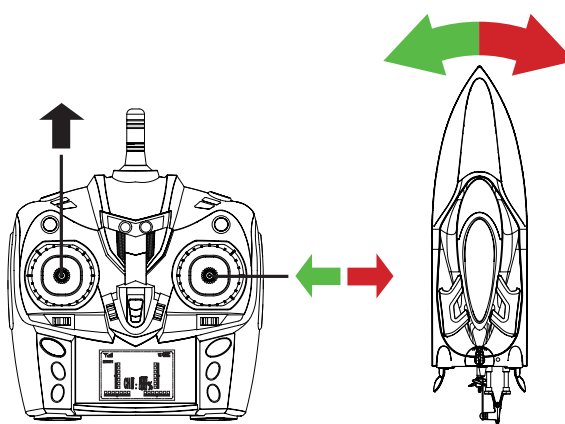

CORRECTION

Push the **THROTTLE STICK** left and the **DIRECTION STICK** right. When you hear a beep sound, it means correction was successful.

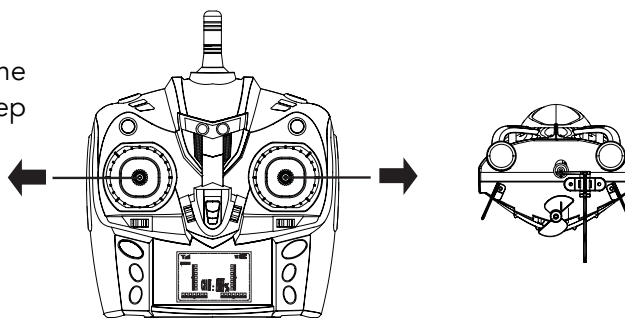

FLIP RECOVERY

1. When the boat is flipped over, push the **DIRECTION STICK** up (Picture 31).
2. Keep the **DIRECTION STICK** up and push the **THROTTLE STICK** up and down until the boat is right-side up (Picture 32).

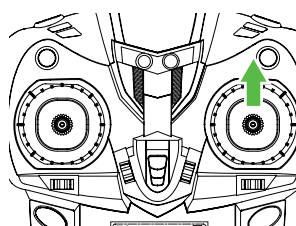

PICTURE 31

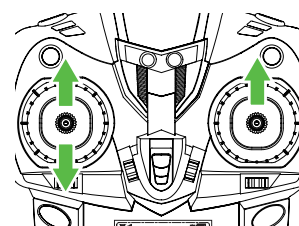

PICTURE 32

MODE 1 TRIM ADJUSTMENTS

TRIM FORWARD OR BACKWARD

When the boat is veering to the front or back, use the TRIM BUTTONS to correct the direction. When the boat is moving forward without touching the THROTTLE STICK, press the BACKWARD TRIM BUTTON until the boat stops moving forward. When the boat is moving backward without touching the THROTTLE STICK, press the FORWARD TRIM BUTTON until the boat stops moving backward.

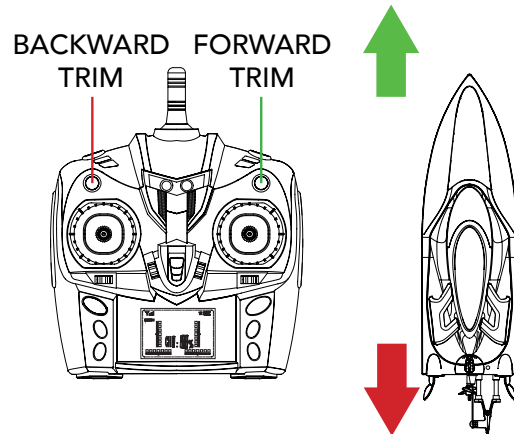

TURN LEFT OR RIGHT

When the boat is veering to the left or right, use the TRIM BUTTONS to correct the direction. When the boat is moving to the left without touching the DIRECTION STICK, press the RIGHT TRIM BUTTON until the boat stops moving left. When the boat is moving to the right without touching the DIRECTION STICK, press the LEFT TRIM BUTTON until the boat stops moving right.

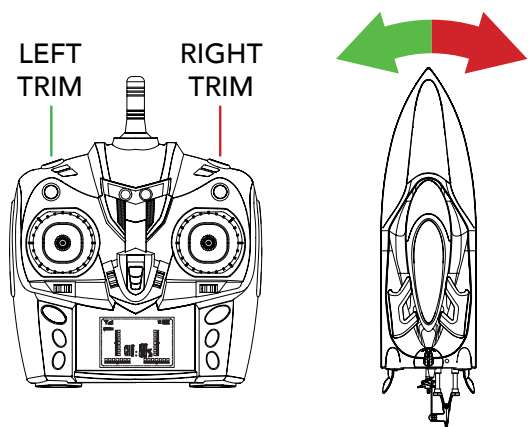

ADDITIONAL FEATURES

TURNING DEGREE

Short press the TURNING DEGREE button in order adjust the degree at which the boat turns. There are 8 total degrees to which this boat can be adjusted. Press 4 times to the left to increase the turning degree or 4 times to the right to decrease the turning degree.

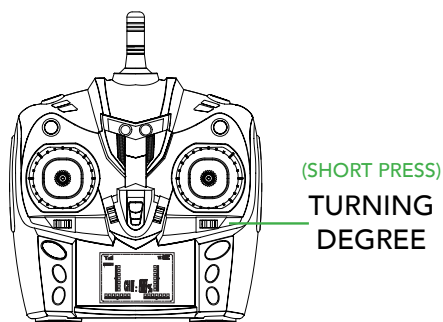

DEMO MODE

Long pressing the TURNING DEGREE button for 3 seconds will engage Demo Mode. This will enable the boat to perform figure eights.

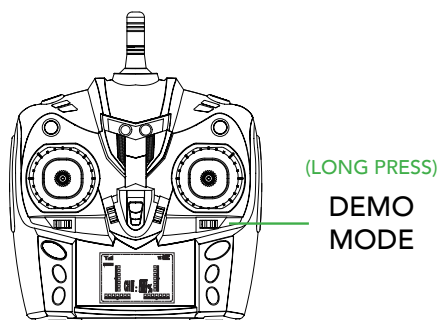

MODE 2 OPERATION CONTROLS

Switching to Mode 2 on your remote (Left/Right Hand Mode - Page 8) will reverse the controls.

MOVE FORWARD OR BACKWARD

Push the THROTTLE STICK up and the boat moves forward. Pull the THROTTLE STICK down and the boat moves backward.

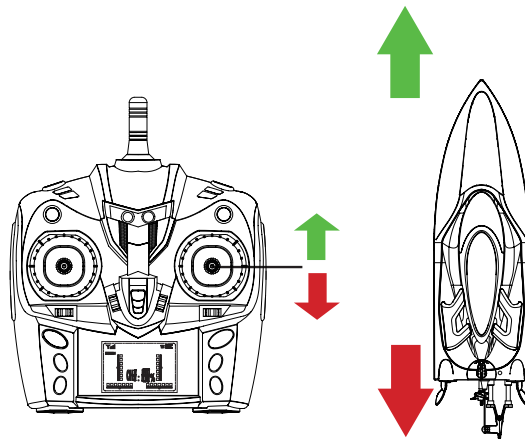

TURN LEFT OR RIGHT

While pushing the THROTTLE STICK forward, pulling the left DIRECTION STICK left will make the boat turn to the left. Pulling the DIRECTION STICK right will make the boat turn to the right.

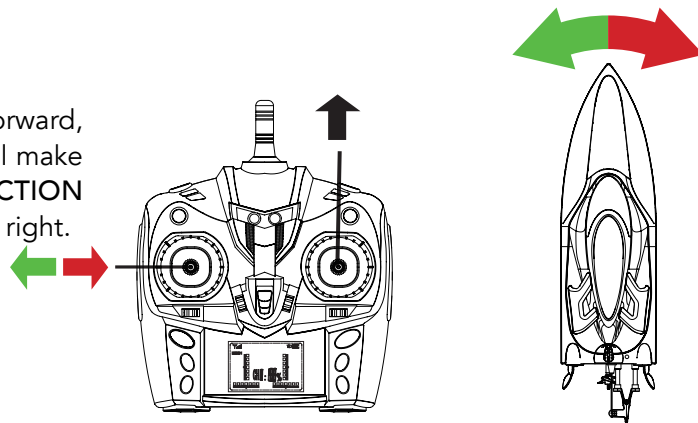

CORRECTION

Push the THROTTLE STICK right and the DIRECTION STICK left. When you hear a beep sound, it means correction was successful.

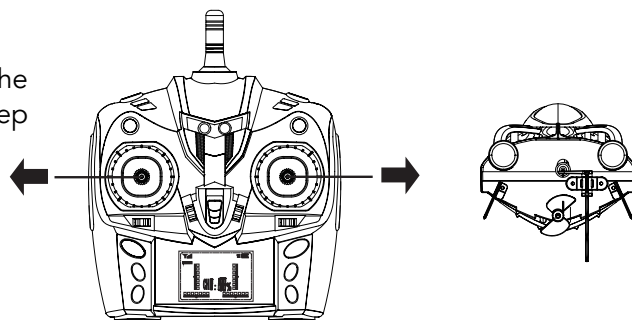

FLIP RECOVERY

1. When the boat is flipped over, push the DIRECTION STICK up (Picture 33).
2. Keep the DIRECTION STICK up and push the THROTTLE STICK up and down until the boat is right-side up (Picture 34).

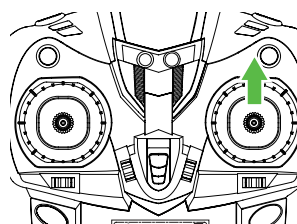

PICTURE 33

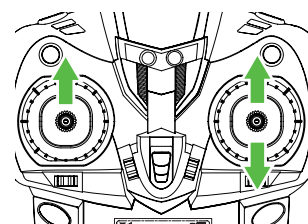

PICTURE 34

MODE 2 TRIM ADJUSTMENTS

TRIM FORWARD OR BACKWARD

When the boat is veering to the front or back, use the **TRIM BUTTONS** to correct the direction. When the boat is moving forward without touching the **THROTTLE STICK**, press the **BACKWARD TRIM BUTTON** until the boat stops moving forward. When the boat is moving backward without touching the **THROTTLE STICK**, press the **FORWARD TRIM BUTTON** until the boat stops moving backward.

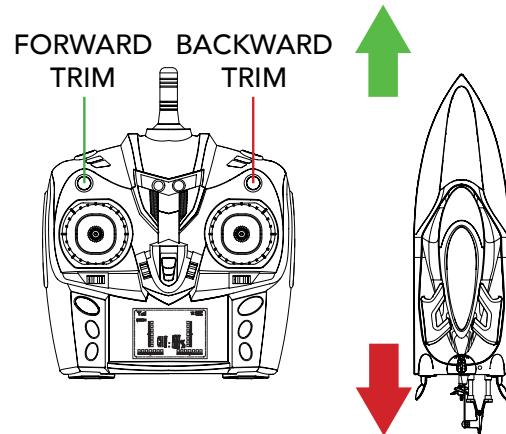

TURN LEFT OR RIGHT

When the boat is veering to the left or right, use the **TRIM BUTTONS** to correct the direction. When the boat is moving to the left without touching the **DIRECTION STICK**, press the **RIGHT TRIM BUTTON** until the boat stops moving left. When the boat is moving to the right without touching the **DIRECTION STICK**, press the **LEFT TRIM BUTTON** until the boat stops moving right.

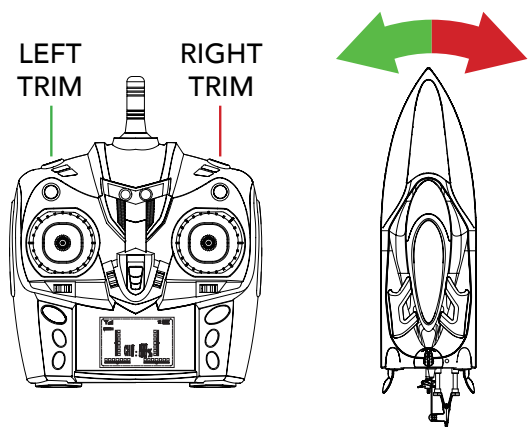

ADDITIONAL FEATURES

TURNING DEGREE

Short press the **TURNING DEGREE** button in order adjust the degree at which the boat turns. There are 8 total degrees to which this boat can be adjusted. Press 4 times to the left to **increase** the turning degree or 4 times to the right to **decrease** the turning degree.

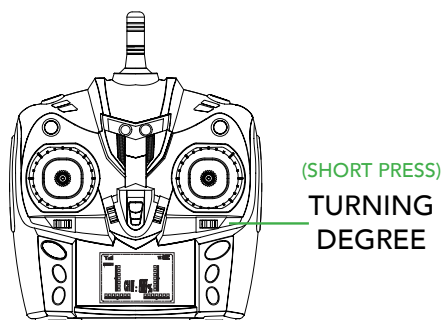





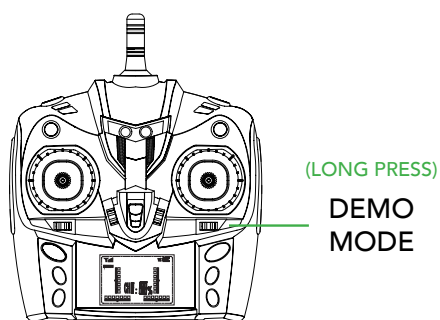



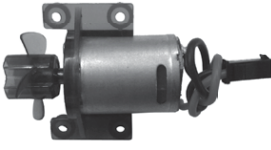

DEMO MODE

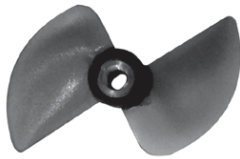
Long pressing the **TURNING DEGREE** button for 3 seconds will engage Demo Mode. This will enable the boat to perform figure eights.

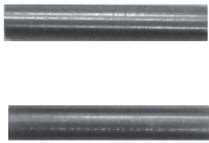
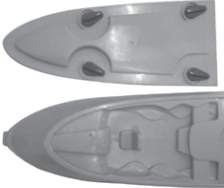

SPARE PARTS

			
Receiving Plate 0001	Motor 0002	Battery 0003	Steering Engine 0004
			
USB Charger 0005	Discharge Pipe 0006	Steering Engine Bar 0007	Propeller 0008
			
Nose Guard 0009	Screw 0010	Spindle Tube 0011	
			
Stern Rudder Position Tube 0012	Body 0013	Hatches 0014	Display Racks 0015
			
Steering Rudder 0016	Guiding Rudders 0017	Silicone Waterproof Plug 0018	Charging Cable 0019

FCC INFORMATION

This equipment has been tested and found to comply with the limits for a Class B digital device, pursuant to part 15 of the FCC Rules. These limits are designed to provide residential protection against harmful interference in a residential installation. This equipment generates, uses and can radiate radio frequency energy and, if not installed and used in accordance with the instructions, may cause harmful interference to radio communications. However, there is no guarantee that interference will not occur in a particular installation. If this equipment does cause harmful interference to radio or television reception. Which can be determined by turning the equipment off and on, the user is encouraged to try to correct the interference by one or more of the following measures:

- Reorient or relocate the receiving antenna.
- Increase the separation between the equipment and receiver.
- Connect the equipment into an outlet on the circuit different from that to which the receiver is connected.
- Consult the dealer or an experienced technician for help.

FCC WARNING

The equipment may generate or use radio frequency energy. Changes or modifications to this equipment may cause harmful interference unless the modifications are expressly approved in the instruction manual. Modifications not authorized by the manufacturer may void user's authority to operate this device.

This device complies with part 15 of the FCC Rules. Operation is subject to the following two conditions:

1. This device may not cause harmful interference, and
2. This device must accept any interference received, including interference that may cause undesired operation.



force1rc.com