

Parts Catalog



GC10

SLICING MACHINES

MODELS: GC9, GC10, GC12 & GC12D

07-30-10

IMPORTANT!

TO EXPEDITE SHIPMENT OF PARTS, ALWAYS SPECIFY MODEL, REV,
PART NUMBER, AND SERIAL NUMBER OF SLICER.

GLOBE FOOD EQUIPMENT COMPANY

2215 East River Road
Dayton, Ohio 45439

Parts Department

Toll Free 1-800-745-6238 • Fax (937) 290-0585

E-Mail: globeinfo@globeslicers.com

Website: www.globeslicers.com

Not for resale

2

Item/Part Number	Description	Qty
1	Sharpener Cover	1
2	Sharpener Assembly	1
5	Sharpening Stone	1
7	Truing Stone	1
9	Sharpener Support	1
10-B	Screw, Sharpener Adjustment	1
10-C	Stop Screw	1
12	Cover Release Knob	1
13	Slicer Table	1
18	Table Hole Cover	1
22	Deflector	1
22-A	Deflector Screw	2
25	Table Adjustment Knob	1
27	Indexing cam	1
28	Power Switch	1
29	Slide Bar Spacer	2
31	Capacitor	1
33	Table Adjustmant Assembly	1
36	Motor, 115V, 60Hz, 1 Phase	1
40	Rubber Foot (Set/4)	1
41-A	Foot Screw	4
42	Slide Bar	1
45	Chute Slide Assembly	1
45-A	Chute Stud	1
47-B	Bearing, Small	1

Item/Part Number	Description	Qty
48	Slide Rod	1
48-A	Spring, Slide Rod	1
52	Drive Hub Assembly	1
54	Drive Belt	1
56	Knife	1
56-A	Screw, Knife Mounting	3
59	Knife Cover	1
59-A	Knife Cover Insert	1
62	Endweight Assembly	1
62-B	Endweight Bumper	1
70-A	Endweight Handle Short (Old Style)	1
70-L	Endweight Handle, Extended (Not shown)	
65	Food Chute	1
65-A	Endweight Rod	1
68	Chute Support	1
70-A	Handle, Chute Support	1
71	Chute Knob	1
73	Cover, Bottom - Plastic	1
81	Label, Warning - English	1
82-F	Label, Warning - French (CSA Only)	1
83-A	Label, Logo - Chefmate	1
88	Label, Overload Reset (CSA Only)	1
89	Switch, Overload Reset (CSA Only)	1
132-3	Power Cord & Three Prong Plug	1

GC10 Components

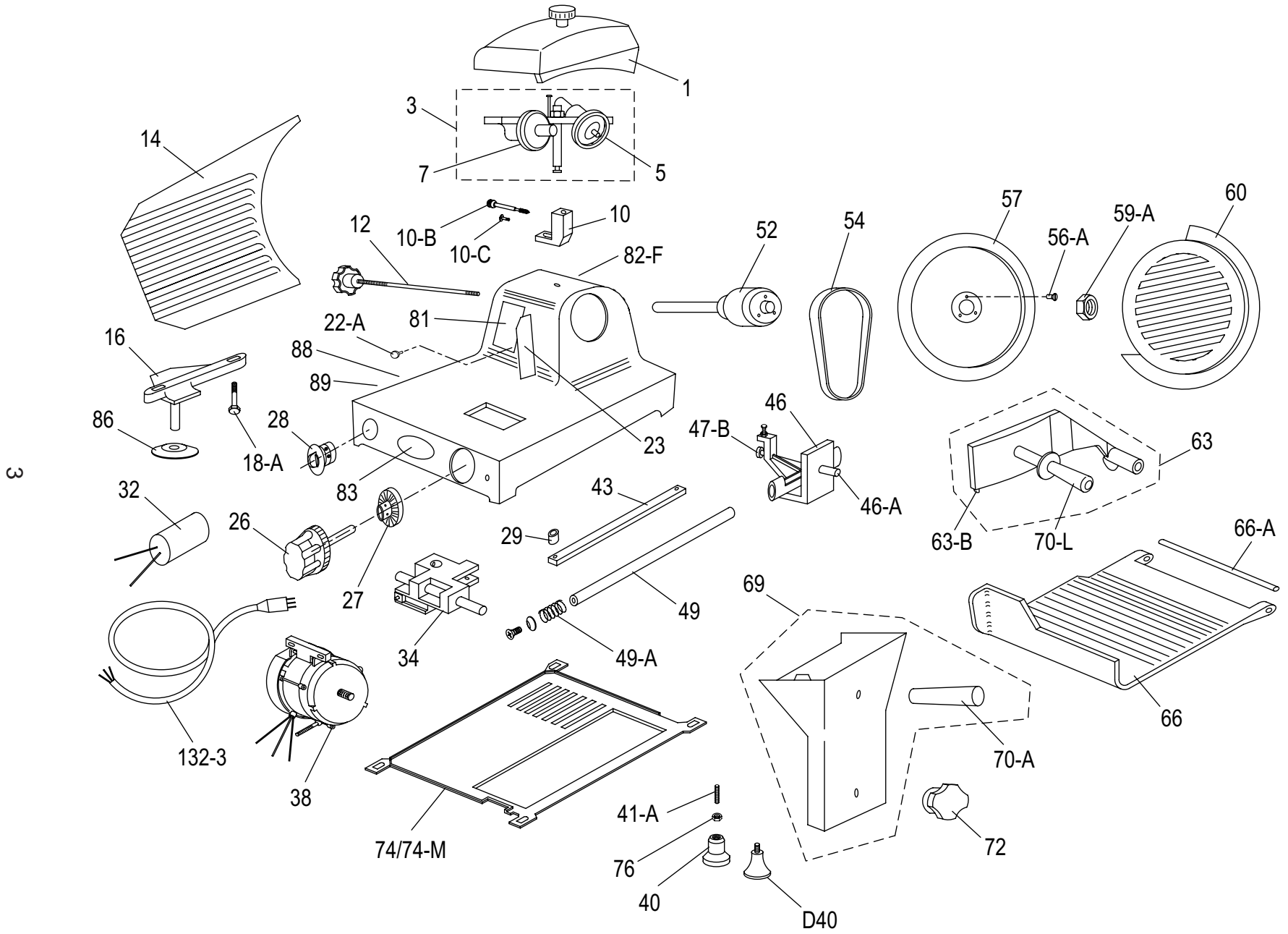

Item/Part Number	Description	Qty
1	Sharpener Cover	1
3	Sharpener Assembly	1
5	Sharpening Stone	1
7	Truing Stone	1
10	Sharpener Support	1
10-B	Screw, Sharpener Adjustment	1
10-C	Stop Screw	1
12	Cover Release Knob	1
14	Slicer Table	1
16	Table Support Bracket	1
18-A	Table Support Screw	2
22-A	Deflector Screw	2
23	Deflector	1
26	Table Adjustment Knob	1
27	Indexing cam	1
28	Power Switch	1
32	Capacitor	1
34	Table Adjustmant Assembly	1
38	Motor, 115V, 60Hz, 1 Phase	1
†D40	Rubber Foot (Set/4), New Style	1
*40	Rubber Foot (Set/4), Old Style	1
*41-A	Foot Screw, Old Style	4
43	Slide Bar	1
46	Chute Slide Assembly	1
46-A	Chute Stud	1
47-B	Bearing, Small	1

*Prior to S/N 114204

†Starting with S/N 114204

Item/Part Number	Description	Qty
49	Slide Rod	
49-A	Spring, Slide Rod	1
52	Drive Hub Assembly	1
54	Drive Belt	1
56-A	Screw, Knife Mounting	3
57	Knife	1
59-A	Knife Cover Insert	1
60	Knife Cover	1
63	Endweight Assembly	1
63-B	Endweight Bumper	1
70-A	Endweight Handle Short (Old Style)	1
70-L	Endweight Handle, Extended	
66	Food Chute	1
66-A	Endweight Rod	1
69	Chute Support	1
70-A	Handle, Chute Support	1
72	Chute Knob	1
*74	Cover, Bottom - Plastic	1
†74-M	Cover, Bottom - Metal	
*76	Nut, Bottom Cover	4
81	Label, Warning - English	1
82-F	Label, Warning - French (CSA Only)	1
83	Label, Logo - Chefmate	1
86	Table Hole Cover	1
88	Label, Overload Reset (CSA Only)	1
89	Switch, Overload Reset (CSA Only)	1
132-3	Power Cord & Three Prong Plug	1

GC12 Components

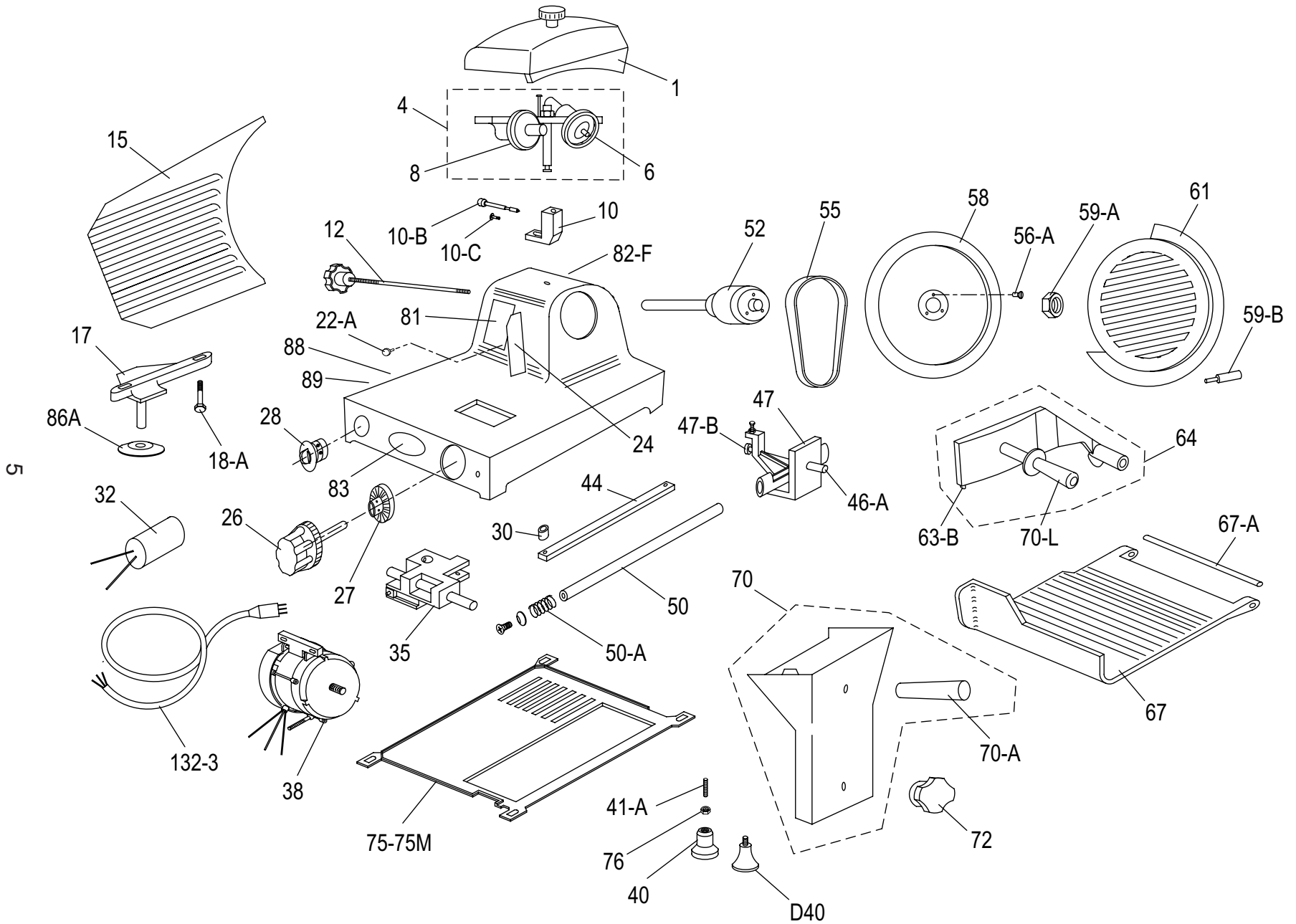

Item/Part Number	Description	Qty
1	Sharpener Cover	1
4	Sharpener Assembly	1
6	Sharpening Stone	1
8	Truing Stone	1
10-B	Screw, Sharpener Adjustment	1
10-C	Stop Screw	1
D10	Sharpener Support	1
D10-A	Sharpener Support Sleeve	1
12	Cover Release Knob	1
15	Slicer Table	1
17	Table Support Bracket	1
18-A	Table Support Screw	2
22-A	Deflector Screw	2
24	Deflector	1
26	Table Adjustment Knob	1
27	Indexing cam	1
28	Power Switch	1
30	Slide Bar Spacer	1
32	Capacitor	1
35	Table Adjustmant Assembly	1
38	Motor, 115V, 60Hz, 1 Phase	1
†D40	Rubber Foot (Set/4), New Style	1
*40	Rubber Foot (Set/4), Old Style	1
*41-A	Foot Screw, Old Style	4
44	Slide Bar	1
47	Chute Slide Assembly	1
46-A	Chute Stud	1
47-B	Bearing, Small	1

*Prior to S/N 131960

†Starting with S/N 131960

Item/Part Number	Description	Qty
50	Slide Rod	1
50-A	Spring, Slide Rod	1
52	Drive Hub Assembly	1
55	Drive Belt	1
56-A	Screw, Knife Mounting	3
58	Knife	1
59-A	Knife Cover Insert	1
59-B	Cover Support Stud	1
61	Knife Cover	1
64	Endweight Assembly	1
63-B	Endweight Bumper	1
70-A	Endweight Handle Short (Old Style)	1
70-L	Endweight Handle, Extended	
67	Food Chute	1
67-A	Endweight Rod	1
70	Chute Support	1
70-A	Handle, Chute Support	1
72	Chute Knob	1
*75	Cover, Bottom - Plastic	1
†75-M	Cover, Bottom - Metal	
*76	Nut, Bottom Cover	4
81	Label, Warning - English	1
82-F	Label, Warning - French (CSA Only)	1
83	Label, Logo - Chefmate	1
86-A	Base Hole Cover	1
88	Label, Overload Reset (CSA Only)	1
89	Switch, Overload Reset (CSA Only)	1
132-3	Power Cord & Three Prong Plug	1

GC12D Components

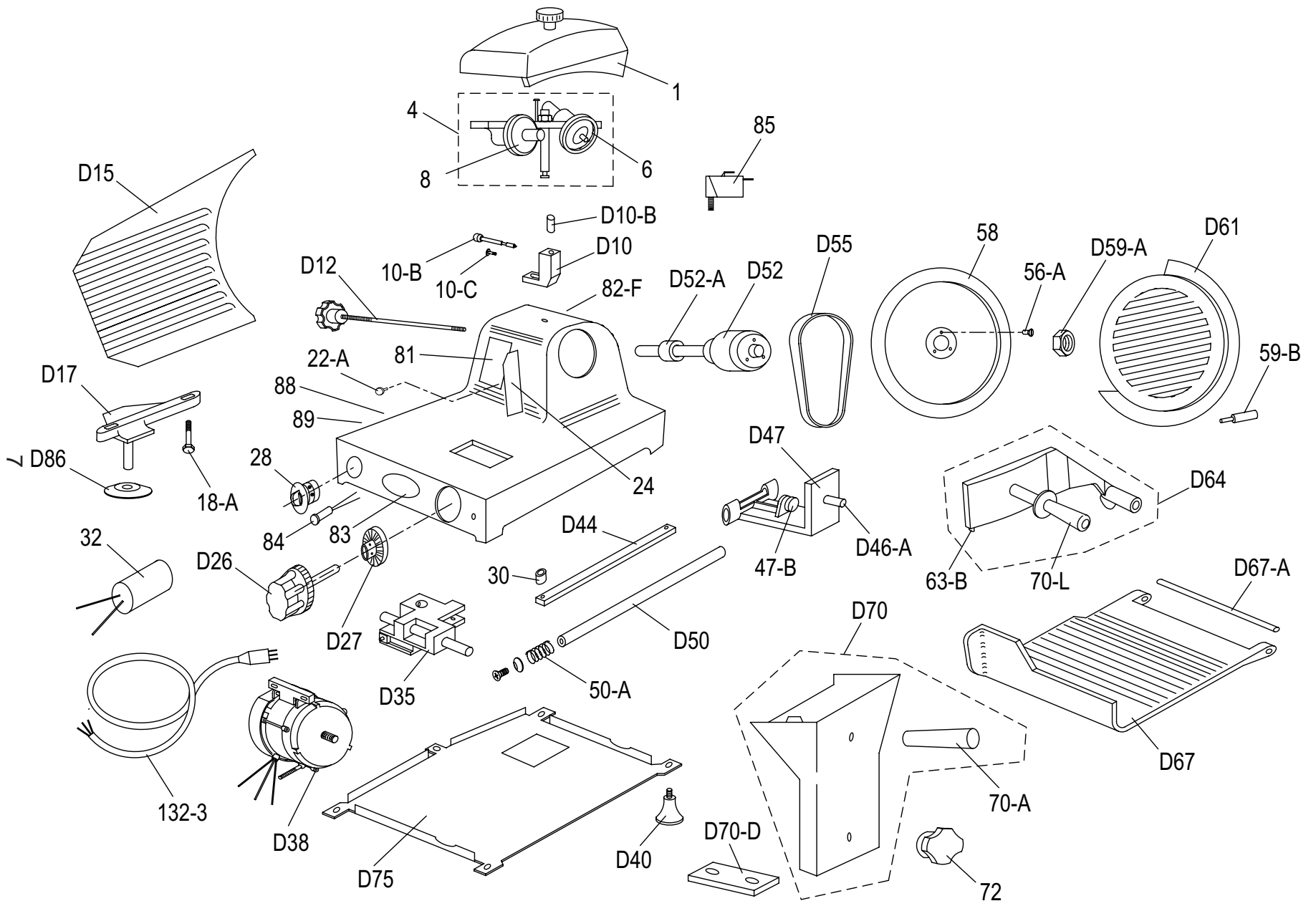

Item/Part Number	Description	Qty
1	Sharpener Cover	1
4	Sharpener Assembly	1
6	Sharpening Stone	1
8	Truing Stone	1
10-B	Screw, Sharpener Adjustment	1
10-C	Stop Screw	1
D10	Sharpener Support	1
D10-B	Sharpener Support Sleeve	1
D12	Cover Release Knob	1
D15	Slicer Table	1
D17	Table Support Bracket	1
18-A	Table Support Screw	2
22-A	Deflector Screw	2
24	Deflector	1
D26	Table Adjustment Knob	1
D27	Indexing cam	1
28	Power Switch	1
32	Capacitor	1
D35	Table Adjustmant Assembly	1
D38	Motor, 115V, 60Hz, 1 Phase	1
D40	Rubber Foot (Set/4), New Style	1
D44	Slide Bar	1
D47	Chute Slide Assembly	1
D46-A	Chute Stud	1
47-B	Bearing, Small	1
D50	Slide Rod	1
50-A	Spring, Slide Rod	1

Item/Part Number	Description	Qty
D52	Drive Hub Assembly	1
D52-A	Microswitch Collar	1
D55	Drive Belt	1
56-A	Screw, Knife Mounting	3
58	Knife	1
D59-A	Knife Cover Insert	1
59-B	Cover Support Stud	1
D61	Knife Cover	1
D64	Endweight Assembly	1
63-B	Endweight Bumper	1
70-A	Endweight Handle Short (Old Style)	1
70-L	Endweight Handle, Extended	
D67	Food Chute	1
D67-A	Endweight Rod	1
D70	Chute Support	1
70-A	Handle, Chute Support	1
D70-D	Chute Support Mounting Plate	1
72	Chute Knob	1
D75	Cover, Bottom - Metal	1
81	Label, Warning - English	1
82-F	Label, Warning - French (CSA Only)	1
83	Label, Logo - Chefmate	1
84	Indicator Light, 110VAC	1
85	Microswitch	1
D86	Base Hole Cover	1
88	Label, Overload Reset (CSA Only)	1
89	Switch, Overload Reset (CSA Only)	1
132-3	Power Cord & Three Prong Plug	1

GC9, GC10 & GC12 Wiring Diagram

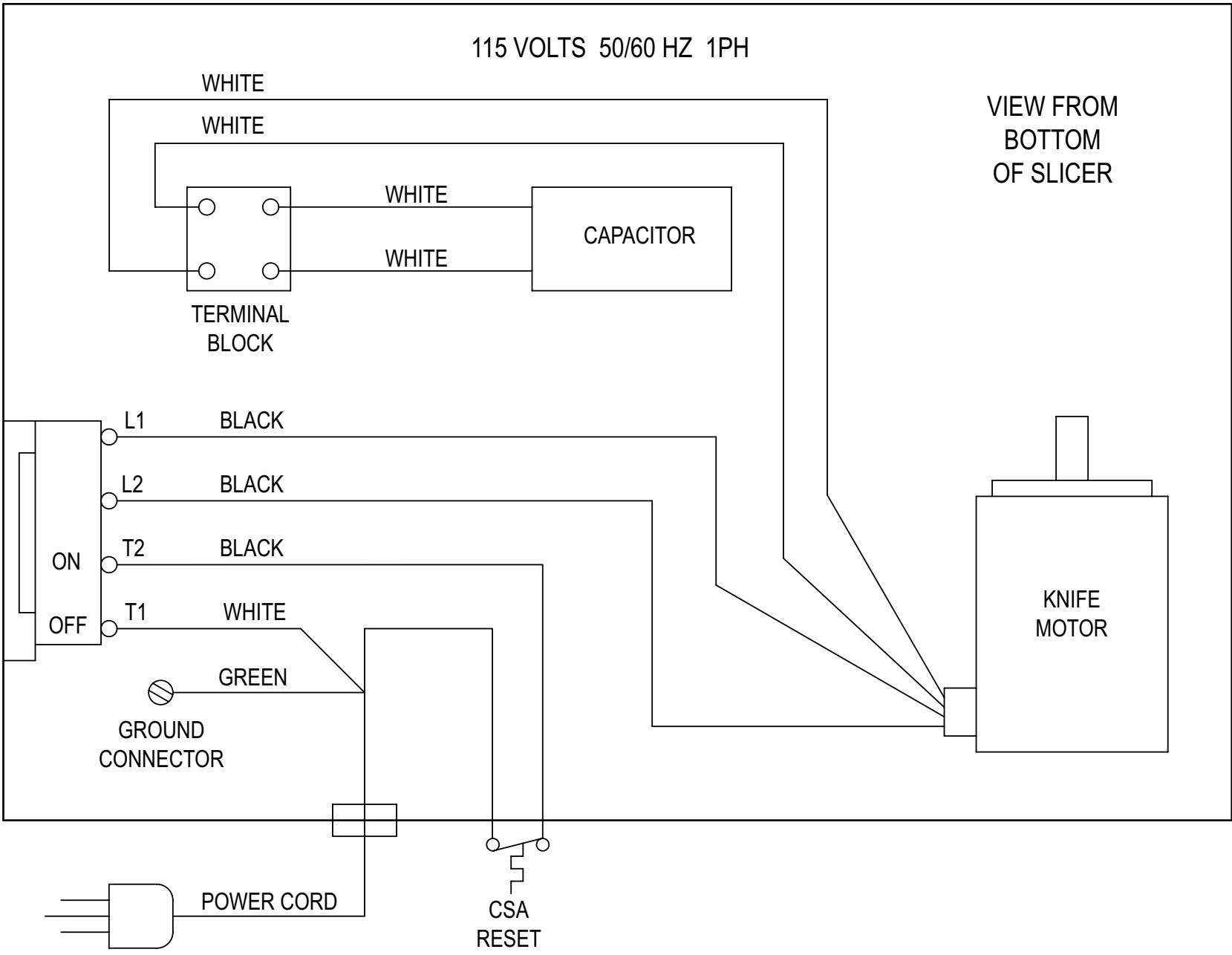

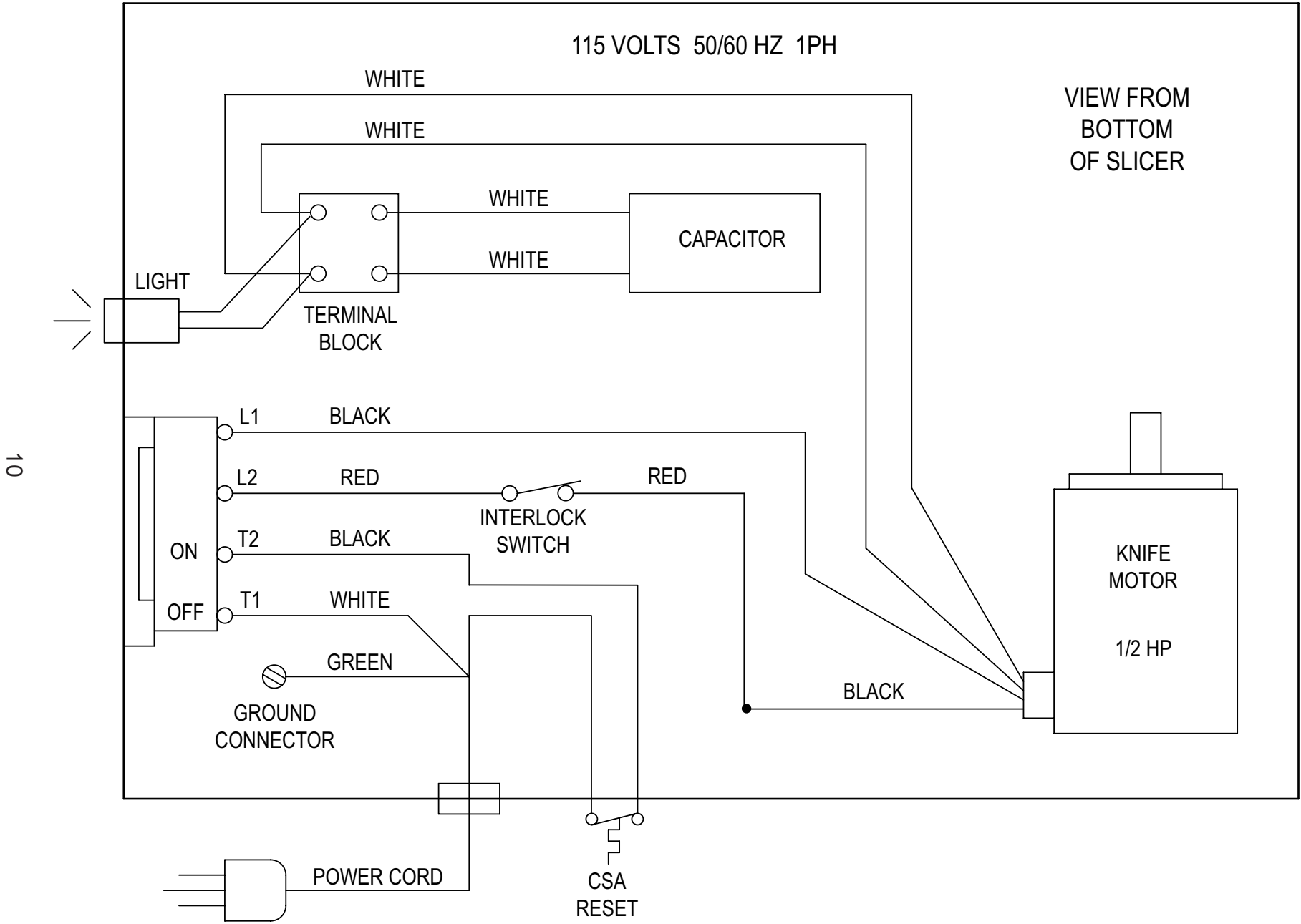

GC12D Wiring Diagram

GFE-GC9, GC10, GC12, GC12D

07/30/2010

Rev C ECN 1499