



 **cafetto®**

**A CLEANING PRODUCT FOR
EVERY MACHINE**



CAFETTO.COM

A CLEANING PRODUCT FOR EVERY MACHINE

19

**MILK
CLEANERS**

14

**SUPER AUTOMATIC
CLEANING TABLETS**

34

**GRINDER
CLEANERS**

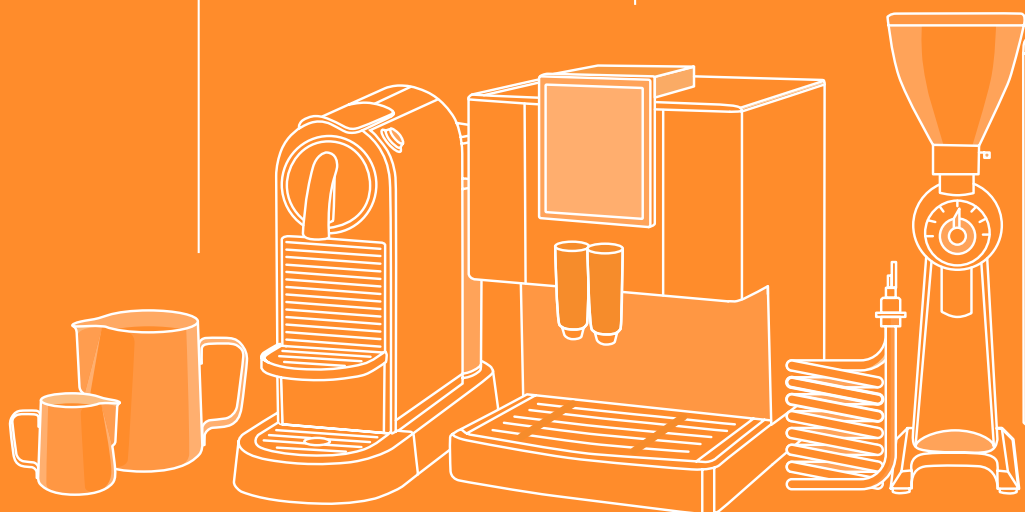

37

**CAPSULE MACHINE
CLEANERS**

25

**DESCALER POWDER
& LIQUIDS**

31

**BREWER &
EQUIPMENT CLEANERS**

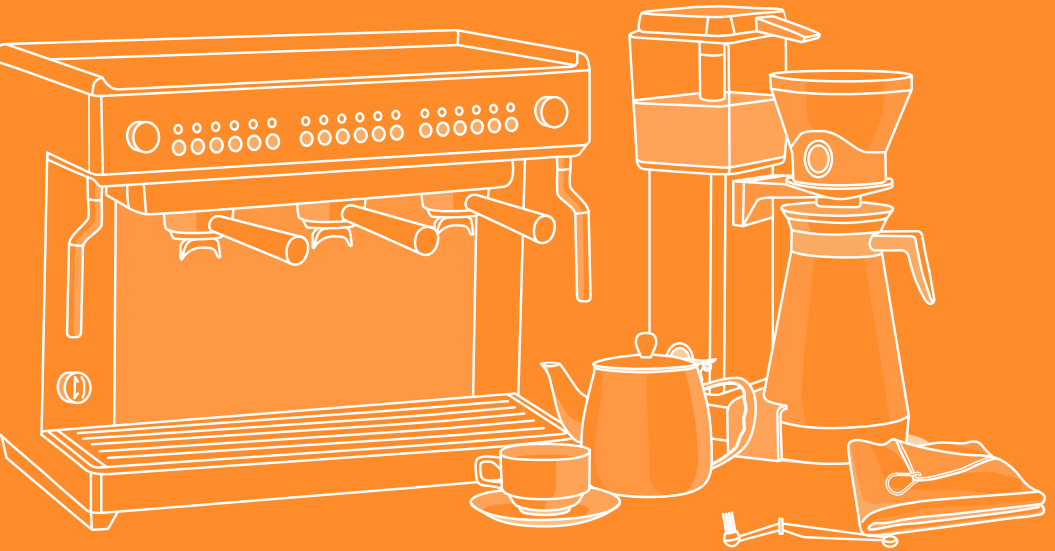

10

**TRADITIONAL ESPRESSO
MACHINE CLEANERS**

39

**GENERAL CLEANING
& ACCESSORIES**

ABOUT US



Cafetto® produces cleaning and sanitation products for espresso, coffee brewing and beverage dispensing equipment. Cafetto® is the industry leader in effective organic and eco-friendly solutions, offering cleaning products to improve equipment performance and simplify cleaning processes. Through its extensive product portfolio and global network, Cafetto® provides cleaning products to both the commercial and domestic markets.



BENEFITS OF CLEANING YOUR EQUIPMENT

- Improve machine and equipment performance
- Increase the life span of the machine
- Increase machine reliability
- Reduce service downtime
- Improve flavour of coffee

OUR PROMISE TO YOU

We stand by the quality of our products. The Cafetto® range has been stringently tested to bring you the most effective products to clean and sanitise your equipment.

**Our products help make your business cleaner, safer and healthier
– protecting people and your business.**

Christopher Short
Managing Director

SPECIALISED CERTIFICATIONS



ACO REGISTERED

All Cafetto® products marked with the Australian Certified Organic (ACO) logo have been registered and are approved for use in organic systems.



OMRI™ LISTED

All Cafetto® products marked with the OMRI™ logo have been listed with the Organic Materials Review Institute as complying with the requirements of the National Organic Program.



NSF

NSF A3, A1 White Book Nonfood Compounds and International Protocol P152. NSF (National Sanitation Foundation) International Protocol P152 relates to espresso machine cleaners that have been evaluated, tested, and passed NSF's stringent toxicology and corrosivity standards. The ingredients and formulation of the products that are NSF certified are safe, leave no harmful residues and do not cause corrosion within the coffee machine.

QR CODE

Products listed in this guide are displayed with a unique Quick Response Code (QR Code) to provide customers with access to detailed product information such as training videos, SDS (Safety Data Sheets) and performance data.

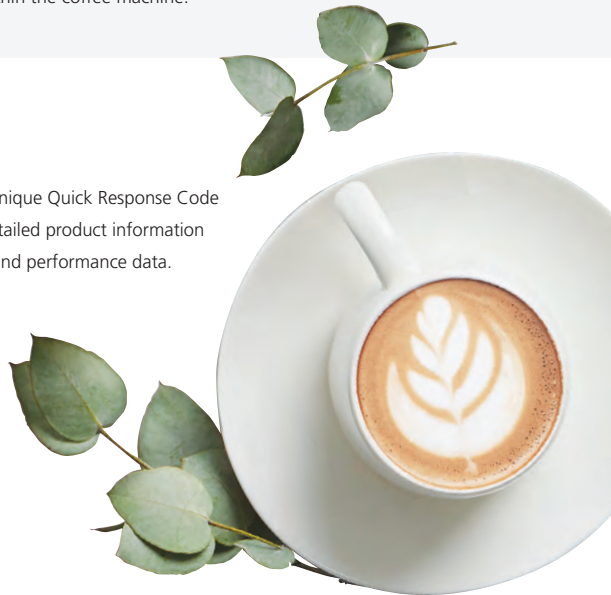

QUALITY THAT'S INDEPENDENTLY CERTIFIED

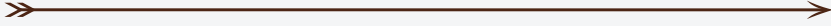

At Cafetto® we recognise the need to protect the health and safety of anyone who comes into contact with our products. That is why we have implemented and maintain a consistent, effective, hygiene system that meets or exceeds global standards, allowing you to have confidence in hygiene and safety with Cafetto® products. We do all of this whilst remaining environmentally conscious across all aspects of our business.



Environment
ISO 14001
SAI GLOBAL

ISO 14001 ENVIRONMENTAL MANAGEMENT SYSTEM

Cafetto® is proudly certified with the ISO 14001 Environmental Management System. This environmental management system is made up of a set of rules and regulations that define how our company interacts with the environment across all aspects of the business. As care for the environment is vital, we follow specific guidelines and processes that focus on:

- Sustainability
- Preventing Pollution
- Minimising our Environmental Footprint

This includes resourceful management processes such as packaging and chemical waste recycling, reducing packaging materials by producing highly concentrated products, eliminating product spills entering the stormwater system with bunding of entire factory site, and using external waste management services. All elements within the Environmental Management System allow Cafetto® to confidently maintain the highest standard of environmentally conscious processes throughout the business.



Food Safety
ISO 22000
SAI GLOBAL

ISO 22000 FOOD SAFETY MANAGEMENT SYSTEM

ISO 22000 ensures the safety of the global food supply chain to the highest standard. It is an internationally recognised certification standard based on the most advanced technological, scientific, and managerial expertise. This certification has created a level standard across food safety management systems worldwide. Cafetto® customers can be assured that our products adhere to this high standard.



Food Safety
CODEX
HACCP



HACCP

Cafetto® is compliant with HACCP requirements for the production of cleaning chemicals. HACCP is a food safety and risk assessment plan that stands for Hazard Analysis and Critical Control Points and outlines seven key principles in food safety:

- Hazard Analysis
- Critical Control Points
- Critical Limits
- Critical Control Monitoring
- Corrective Action
- Procedures
- Record Keeping

HACCP can be applied to all processes throughout each and every stage of the food supply chain. This includes production, preparation, packaging and distribution.



Quality
ISO 9001



ISO 9001:2015

ISO 9001 is a standard that sets out the requirements for a quality management system. It helps businesses and organisations to be more efficient and improve customer satisfaction. Our organisation complies with the requirements of ISO9001:2015 for the development, manufacture, and despatch of cleaning chemicals.

CAFETTO ORGANIC RANGE

Our organic range contains only ingredients that are sustainably sourced and free from Genetically Modified Organisms and phosphates. All products are biodegradable and certified for use in organic systems, which means that if you're using organic coffee beans and milk, you're fulfilling an end-to-end organic experience for your customers.

Our organic range of products contains ingredients that are either plant derived or naturally occurring:

TARTARIC ACID

Sourced from plant material, in particular from grapes during the wine-making process, but also found in other fruit including apricots, apples and bananas. It is a natural souring agent in foods and is commonly used as a leavening agent in bread-making, which along with sodium bicarbonate, causes the bread to rise. It is used in Cafetto® products to assist dissolution by effervescence, whilst also contributing to cleaning by removing hard water elements.

CITRIC ACID

Derived from citrus fruits, such as orange, lemon, lime and grapefruit, it is produced via biological fermentation. In ice-cream it is used as an emulsifier to keep the dairy fats suspended. It is used in Cafetto® products to assist dissolution by effervescence, whilst also contributing to cleaning by removing hard water ions.

SODIUM CARBONATE

Produced by the purification of 'trona', a naturally-occurring mineral from the Green River Basin in Wyoming, USA. It can also be derived from kelp or seaweed. This ingredient is found in toothpaste and is also used in bakery products. It is used in our products as a very effective cleaning agent.

SODIUM CITRATE

Derived from maize sugar via fermentation, it is found in many drinks and is used in the production of some cheeses. It is used to optimise the pH during the cleaning process.

SODIUM PERCARBONATE

This is an oxygen releasing agent that is widely used in toothpaste and denture cleaning tablets as well as other cleaning preparations. It is a highly effective cleaning and bleaching agent.

POTASSIUM CARBONATE

This is an alkaline agent made from naturally occurring minerals. It is often used in the production of wine and as a baking agent. It is one of the ingredients that provides our organic range with its exceptional cleaning performance.

Our organic range is triple certified by three independent regulatory bodies – OMRI, NSF and ACO, and has undergone stringent testing to ensure each product in the range effectively cleans coffee equipment.

WHY USE ORGANIC CLEANING PRODUCTS?

Do you use organic coffee?
Are you concerned about using GMO products and phosphates?

The Cafetto® Organic Range is the best choice for customers who are looking for an alternative to traditional espresso machine cleaners.

Using a cleaning product that is certified for organic use, means that if you're using organic coffee beans and milk, you're upholding an end-to-end organic experience for your customers.

OUR ORGANIC PRODUCTS ARE FREE FROM

- ✗ Genetically Modified Organisms
- ✗ Phosphates
- ✗ Corrosive chemicals
- ✗ Chlorine and quaternary sanitisers



TRADITIONAL ESPRESSO MACHINE CLEANERS

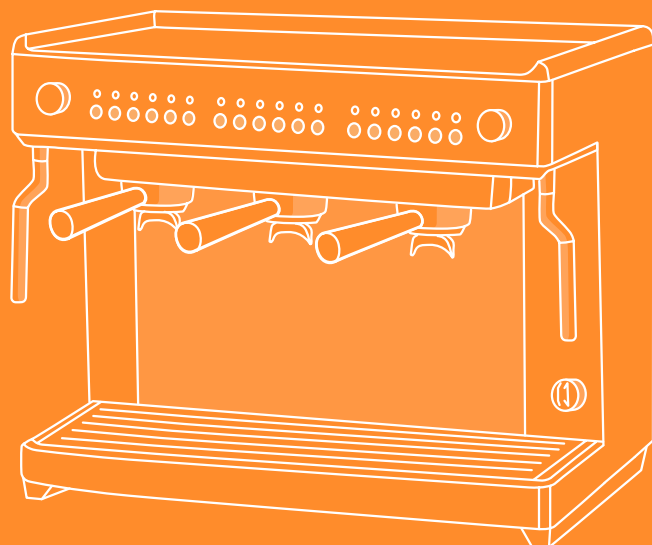

TRADITIONAL ESPRESSO MACHINE CLEANERS

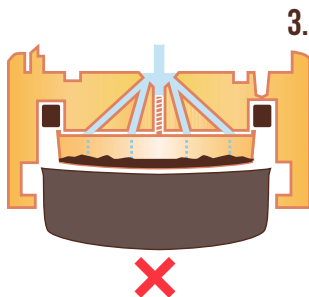
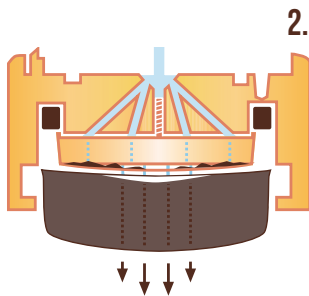
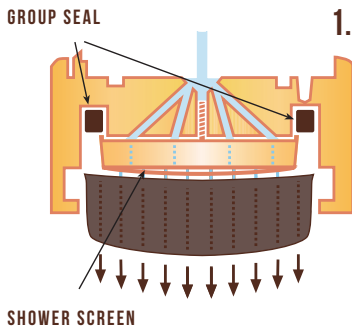
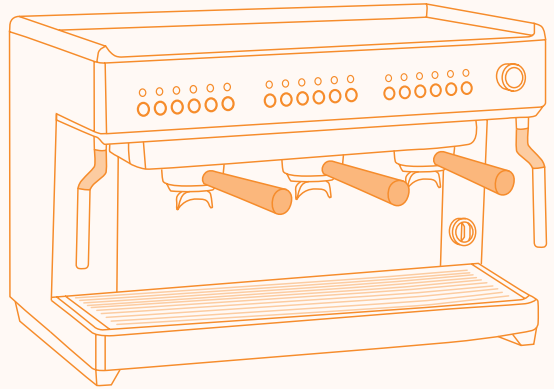

WHY CLEAN?

Daily use of an espresso machine cleaner on commercial machines will reduce the frequency of machine services, lengthen the lifespan of your machine and improve the quality of coffee extraction.

1. **Clean shower screen:** means good, even extraction:
 - Good crema
 - Excellent taste
2. **Partially blocked shower screen:** means over extraction in a concentrated area:
 - Poor crema
 - Bitter taste
3. **Fully blocked shower screen:**
 - Service call required

Cafetto® has a comprehensive range of high performance cleaners that are formulated to clean espresso machine group heads, valves and lines.



ESPRESSO MACHINE POWDERS

Cafetto's espresso machine cleaning powders remove coffee oils, grounds and stains, improving the taste and aroma after the machine is cleaned.

Powders can also be used diluted to soak group handles and filters and remove stains, keeping your components in excellent condition.



ESPRESSO CLEAN®

Effectively removes coffee oils, grounds and stains.

RECOMMENDED FOR:

Traditional espresso machines

AVAILABLE IN:

18 x 5g sachets per box (carton code E10253 - 12 boxes)

500g jars (carton code E25121 - 12 jars)

1kg jars (carton code E11839 - 12 jars)

CERTIFICATIONS:



NSF Protocol P152
Health Effects and Corrosivity
of Commercial Espresso
Machine Chemical Cleaners



EVO®

Certified for organic use, all EVO® ingredients are all rapidly biodegradable meeting international standards.

RECOMMENDED FOR:

Traditional espresso machines

AVAILABLE IN:

18 x 5g sachets per box (carton code E15434 - 12 boxes)

500g jars (carton code E29160 - 12 jars)

1kg jars (carton code E29120 - 12 jars)

CERTIFICATIONS:

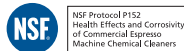

NSF Protocol P152
Health Effects and Corrosivity
of Commercial Espresso
Machine Chemical Cleaners



For Logo Use Only

Portion control ensures profit margins. A convenient portion controlled dose, these tablets can be used instead of powdered espresso machine cleaners.

One tablet in the group head removes coffee oils, grounds and stains just as effectively as traditional espresso machine cleaning powders.



ESPRESSO MACHINE TABLETS



ESPRESSO CLEAN® TABLETS

Effectively removes coffee oils, grounds and stains.

RECOMMENDED FOR:

Traditional espresso machines

AVAILABLE IN:

150 tablet jars (carton code E27893 - 12 jars)

CERTIFICATIONS:

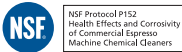

TEVO® MAXI TABLETS

Certified for organic use, all TEVO® Maxi ingredients are all rapidly biodegradable meeting international standards.

RECOMMENDED FOR:

Traditional espresso machines

AVAILABLE IN:

150 tablet jars (carton code E27852 - 12 jars)

CERTIFICATIONS:



SUPER AUTOMATIC CLEANING TABLETS

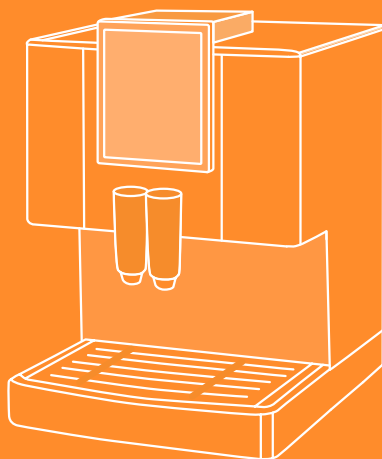

WHICH ONE DO I NEED?



Different brands and styles of super automatic espresso machine are unique and require a cleaning tablet with a specific dissolution time, size and shape.

QUICK TABLET REFERENCE GUIDE

PRODUCT NAME	TABLET WEIGHT	TABLET HEIGHT	TABLET DIAMETER	CERTIFIED	ORGANIC	REMOVES COFFEE RESIDUE	REMOVES MILK RESIDUE
TEVO® Mini	1.5g	4mm	16mm	NSF BFA OMRI	✓	✓	
B30	2.7g	10mm	14mm			✓	
F20	2.0g	5mm	16mm	NSF		✓	
J25	2.5g	12mm	15mm			✓	
M35	3.0g	10mm	17mm			✓	✓
N10	1.0g	8mm	10.5mm			✓	
S15	1.5g	4mm	16mm	NSF		✓	

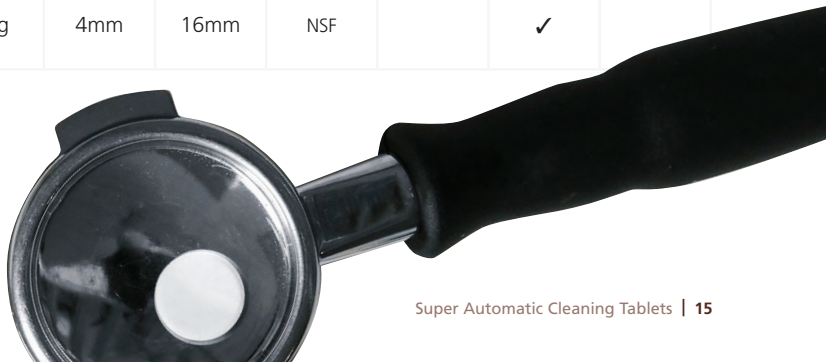

SUPER AUTOMATIC CLEANING TABLETS

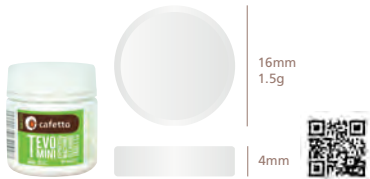
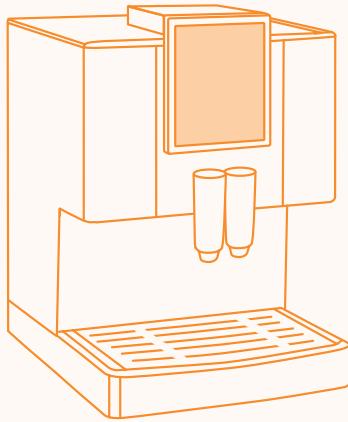

TEVO® MINI TABLETS

Certified for organic use, all TEVO® Mini ingredients are all rapidly biodegradable meeting international standards.

RECOMMENDED FOR:

Cleaning the coffee brew groups of various domestic espresso machines

AVAILABLE IN:

8 tablet blister packs (carton code E11927 - 40 blister packs)

100 tablet jars (carton code E10335 - 12 jars)

CERTIFICATIONS:



NSF Protocol P152
Health Effects and Corrosivity
of Commercial Espresso
Machine Chemical Cleaners



B30 TABLETS

B30 tablets safely and completely remove coffee oils and residues of selected super automatic espresso machines.

RECOMMENDED FOR*:

Carimali | La Cimbali | Rex Royal

AVAILABLE IN:

150 tablet jars (carton code E29018 - 4 jars)

*These are the registered trademarks of their respective owners and are not associated.

We understand that each machine is unique and requires a specific tablet with specific parameters including dissolution time, size and shape.

Cafetto's tablets are formulated and manufactured to the highest standards ensuring that each tablet remains completely intact from when it is produced, to when it is used.



SUPER AUTOMATIC TABLETS



F20 TABLETS

F20 tablets safely and completely remove coffee oils and residues of selected super automatic espresso machines.

RECOMMENDED FOR*:

Acorto | Concordia | Faema
Franke | Gaggia | Swiss Egro

AVAILABLE IN:

100 tablet jars (carton code E29782 - 12 jars)
200 tablet jars [NA Europe] (carton code E29777 - 4 jars)

CERTIFICATIONS:



J25 TABLETS

J25 tablets safely and completely remove coffee oils and residues of selected super automatic espresso machines.

RECOMMENDED FOR*:

Jura | Krups

AVAILABLE IN:

40 tablet jars (carton code E29941 - 12 jars)

*These are the registered trademarks of their respective owners and are not associated.

SUPER AUTOMATIC CLEANING TABLETS



M35 TABLETS

This 2-in-1 tablet safely and completely removes coffee oils and residues of selected super automatic espresso machines while removing milk residue and milk stone.

RECOMMENDED FOR*:

Cafina/Melitta

AVAILABLE IN:

150 tablet jars (carton code E29840 - 12 jars)



N10 TABLETS

N10 tablets safely and completely remove coffee oils and residues of selected super automatic espresso machines.

RECOMMENDED FOR*:

Nuova Simonelli Microbar | WMF

AVAILABLE IN:

50 tablet jars (carton code E29983 - 24 jars)



S15 TABLETS

S15 tablets safely and completely remove coffee oils and residues of selected super automatic espresso machines.

RECOMMENDED FOR*:

Breville | De Longhi | Miele | Rancilio | Saeco
Schaerer | SCS | Solis | Stentorfield | Sunbeam

AVAILABLE IN:

8 tablet blister packs (carton code E25570 - 15 blister packs)

60 tablet jars [N/A Europe] (carton code E29920 - 12 jars)

100 tablet jars (carton code E29736 - 12 jars)

*These are the registered trademarks of their respective owners and are not associated.



MILK CLEANERS



MILK CLEANERS

MILK LINES, FROTHERS & EQUIPMENT

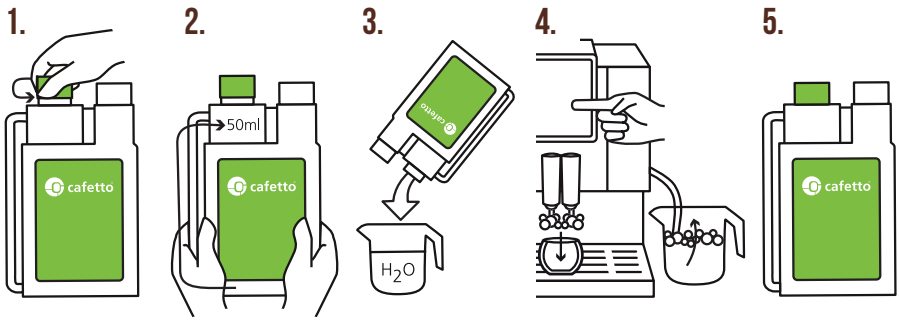
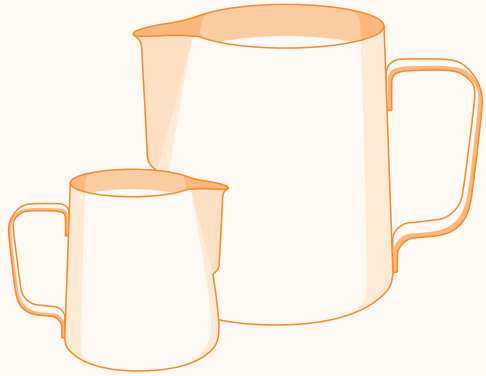

The MFC® range has been developed to sanitise, remove milk residue and hard water scale from milk lines and frothers. Whether you're dealing with hard water or need a cleaner that can break down build up from milk-based products, Cafetto® has a product suited to your requirements with both alkaline and acidic products on offer.

Rinse or flush the milk line before and after using cleaning products to ensure best performance.

All our Milk Frother Cleaner (MFC®) bottles contain a chamber for convenient measuring and correct dosing.

1. Simply loosen the coloured cap over the chamber.
2. Gently squeeze the bottle until the reservoir measures the required amount of solution.
3. Take off the coloured cap and pour out the solution.
4. Begin the cleaning process according to the instructions on the bottle.
5. Always remember to replace the coloured cap and close tight until the next application is required.

Acidic milk cleaners are specially formulated for hard water conditions.

Acidic cleaners deliver high levels of effective scale removal while sanitising. Milk lines must be flushed with water before use with acidic cleaners.



ACIDIC LIQUID MILK CLEANERS



MFC® GREEN

An acidic, organic descaler. MFC® Green contains biodegradable detergents and is derived from natural acids. It is recommended that MFC® Green is used more frequently than the other MFC® cleaners due to its milder properties.

RECOMMENDED FOR:

Organic systems

AVAILABLE IN:

1L bottles with dispensing chamber
(carton code E27885 - 6 bottles)

CERTIFICATIONS:



Nonfood Compounds
Program Listed (A3)
(147359)



Certified
Allowed
Input
KOSHER CERTIFICATION



MFC® RED

A high performance acidic milk line cleaner possessing strong descaling capabilities to breakdown scale while also removing milk build-up.

RECOMMENDED FOR:

Weekly use on machines and equipment with hard water conditions

AVAILABLE IN:

1L bottles with dispensing chamber
(carton code E14220 - 6 bottles)

CERTIFICATIONS:



Nonfood Compounds
Program Listed (A3)
(15135)



Alkaline cleaners provide excellent cleaning capabilities for heavy milk deposits in instances where there is a build-up of milk in the milk lines.

Alkaline cleaners are recommended for machines using dairy products that are high in fat such as full cream milk, cream or ice cream. They also control scale when used frequently.

ALKALINE MILK CLEANERS



MFC® BLUE

A high performance alkaline milk line cleaner designed for machines used at a high frequency.

We recommend using an acidic milk frother cleaner or descaler through the milk lines periodically to remove any scale build up in the lines.

AVAILABLE IN:

1L bottles with dispensing chamber
(carton code E14005 - 6 bottles)

CERTIFICATIONS:



RECOMMENDED FOR:

Daily use on machines and equipment with high volume milk use

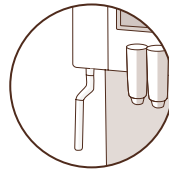

Steam Wands



Milk Jugs



Blenders

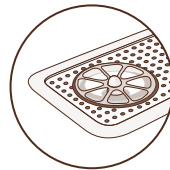

Jug Rinsers

MILK CLEANING TABLETS & POWDERS



MFC® TABS BLUE

Alkaline tablets designed to clean and control milk stone in automatic machine milk lines and frothers.

RECOMMENDED FOR:

Daily use for high volume milk use

AVAILABLE IN:

62 tablet jars (carton code E10297 - 12 jars)



MFC® TABS RED

Acidic tablets designed to clean and descale milk lines, frothers and parts of automatic machines.

RECOMMENDED FOR:

Weekly use for hard water conditions

AVAILABLE IN:

62 tablet jars (carton code E10298 - 12 jars)



MFC® POWDER BLUE

Alkaline powder designed to clean and control milk stone in automatic machine milk lines and frothers.

RECOMMENDED FOR:

Daily use for high volume milk use

AVAILABLE IN:

12 x 10g sachets per box (carton code E12177 - 12 boxes)
500g jars (carton code E11840 - 12 jars)



MFC® POWDER RED

Acidic powder designed to clean and descale milk lines, frothers and parts of automatic machines.

RECOMMENDED FOR:

Weekly use for hard water conditions

AVAILABLE IN:

12 x 10g sachets per box (carton code E11427 - 12 boxes)
500g jars (carton code E11842 - 12 jars)

WHICH ONE SHOULD I USE?



There are many factors to consider when choosing a suitable milk cleaner for your machine. It is important to effectively clean all milk components of a machine to avoid any blockages, prevent breakdowns, and remove odour and bacteria.

QUICK MILK CLEANER REFERENCE GUIDE

PRODUCT NAME	DESCALES	SANITISES	ALKALINE	ACIDIC	CERTIFIED	ORGANIC
MFC® Blue Liquid		✓	✓		NSF	
MFC® Green Liquid	✓	✓		✓	NSF BFA OMRI	✓
MFC® Red Liquid	✓	✓		✓	NSF	
MFC® Powder Blue		✓	✓			
MFC® Powder Red	✓			✓		
MFC® Tabs Blue			✓			
MFC® Tabs Red	✓			✓		

Note: When using acidic cleaners, the milk lines must be flushed and purged of milk prior to the cleaning process. If this cannot be done (in the case of recirculating machines), use an alkaline cleaner.

DESCALER POWDER & LIQUIDS

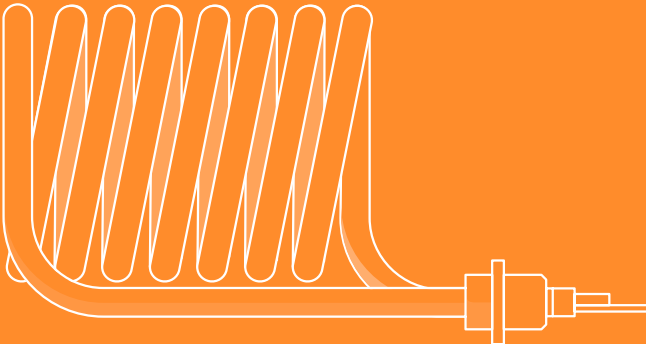

DESCALER POWDER & LIQUIDS

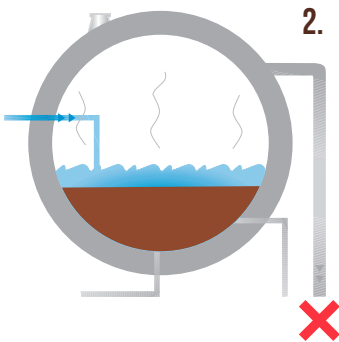
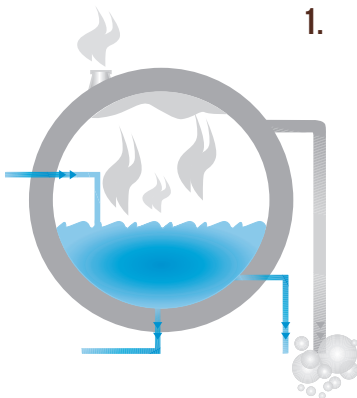
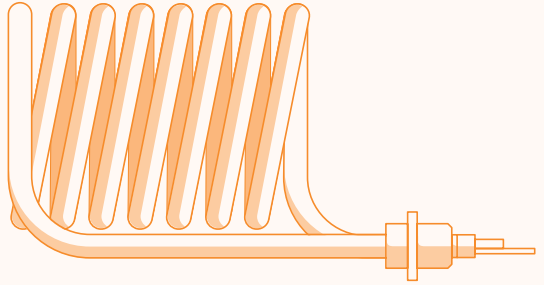

WHY DESCALE?

Scale build-up causes equipment downtime leading to increased machine service frequency, more part replacements and a shortened machine lifespan. Scale build-up also reduces the quality of espresso flavour.

1. Scale free boiler:

- Pressure able to build-up
- Steam wand works effectively
- Hot water is able to drain

2. Scaled up boiler:

- Lack of pressure
- Steam wand not working
- Unable to drain
- Taints taste
- Service call required

Cafetto® has a comprehensive range of high performance and eco-friendly descalers to suit both service technicians and home users.

Increase machine reliability by using Cafetto's descaling range to get the most out of your equipment.

Keep your machine scale free to avoid equipment downtime, increased machine service frequency, more part replacements and a shortened machine lifespan.



DESCALER POWDER & LIQUIDS



LOD RED

An eco-friendly, highly concentrated liquid descaler which rapidly and easily removes lime scale and calcium build up. LOD Red has been developed for use on machines with heavy scale build up and for service technicians.

RECOMMENDED FOR:

Removing hard water scale from metal surfaces in contact with hot water such as espresso machine water tanks, coffee brewing and other hot water equipment.

AVAILABLE IN:

- 1L bottles with dispensing chamber (carton code E12312 - 6 bottles)
- 5L bottles (carton code E13673 - 2 bottles)

CERTIFICATIONS:



LOD GREEN

Designed to remove scale build up from espresso machine water tanks, boilers and coffee brewers, LOD Green can also be used in kettles, urns and bain maries. Contains a synergistic blend of 4 organic acids that provide excellent scale removal with frequent use. Safer for the environment, safer for you.

RECOMMENDED FOR:

Removing hard water scale from espresso machine boilers, coffee and milk delivery lines.

AVAILABLE IN:

- 1L bottles with dispensing chamber (carton code E25482 - 6 bottles)
- 5L bottles (carton code E26200 - 2 bottles)

CERTIFICATIONS:



DESCALER POWDER & LIQUIDS



ORGANIC DESCALER

Perfectly suited to domestic or small office machines. Organic Descaler is a safe and effective solution for removing hard water scale from thermoblock espresso machine lines, capsule machines and boilers. This product can also be used to descale kettles.

RECOMMENDED FOR:

Descaling domestic or small office coffee machines and kettles

AVAILABLE IN:

250ml bottles (carton code E27434 - 12 bottles)

CERTIFICATIONS:



RESTORE

A safe and effective eco-friendly powder descaler for removing hard water scale from espresso machine boilers, coffee and milk delivery lines.

RECOMMENDED FOR:

Removing hard water scale from espresso machine boilers, coffee and milk delivery lines, domestic coffee machines and kettles

AVAILABLE IN:

25g sachets [N/A Europe] (carton code E14244 - 70 sachets)

4 x 25g sachets per box (carton code E28303 - 12 boxes)

1kg jars (carton code E27889 - 4 jars)

CERTIFICATIONS:



Nonfood Compounds
Program Listed (63)
(149546)



DESCALING POWDER WITH A PERFORMANCE INDICATOR



SPECTRA DESCALER

An eco-friendly powder descaler which visually indicates whether a descaling cycle has been successful using pH-sensitive dye compounds.

Orange indicates an effective descaling cycle, and blue indicates that another descaling cycle is required.

RECOMMENDED FOR:

Lime scale and calcium build up from espresso machine water tanks, boilers and coffee brewers

AVAILABLE IN:

4 x 25g sachets per box (carton code E12173 - 12 boxes)

600g jars (carton code E18091 – 12 jars)

CERTIFICATIONS:



Orange – Effective descaling cycle

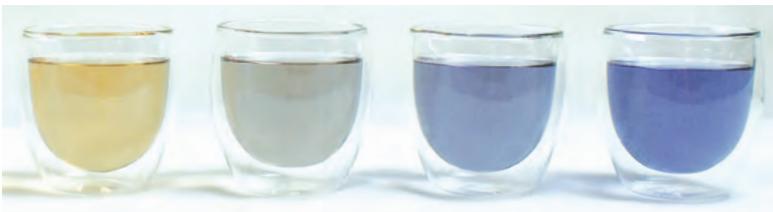

Brown/Grey/Blue – Another descaling cycle is required

THE IMPORTANCE OF DESCALING

In many areas, water quality is a significant problem affecting the efficient operation of an espresso machine. Given that water constitutes 98% of an espresso it is not surprising the water quality issue, therefore, is an issue that must be addressed.

Water quality relates to these three factors - particulate matter like sediment, chemicals such as chlorine, and naturally occurring elements. All these factors may vary throughout the year, season to season, and as authorities source water from different areas, making it essential to provide treatment to address each factor.

WHAT IS HARD WATER?

'Hard water' occurs when water contains high levels of dissolved minerals including both calcium and magnesium. Water hardness cannot be removed by water filters including re-mineralised reversed osmosis water.

Interestingly, espresso made from hard water tastes better as the coffee extraction flavour intensifies with harder water.

WHAT IS SCALE?

Hardness in water can cause scale deposits. This occurs when a build-up of mineral deposits forms a noticeable white crust on the heating element.

The build-up of scale increases the amount of energy required to heat the water, resulting in more repairs and eventually shortening the lifespan of equipment.

Once scale has formed in the boiler and pipe network, it can only be removed by the use of specific acidic descaling chemicals.

WHAT IS THE DIFFERENCE BETWEEN AN ESPRESSO CLEANER AND A DESCALER?

Espresso machine cleaners are alkaline, therefore while they are effective removing coffee oils, they will have little impact on scale removal.

The correct use of a descaler will remove the scale from the boiler and machine pipe work, improving machine performance and reducing service costs and downtime.

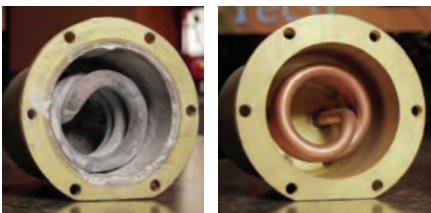

Scaled Boiler

Descaled Boiler



BREWER & EQUIPMENT CLEANERS



BREWER & EQUIPMENT CLEANERS

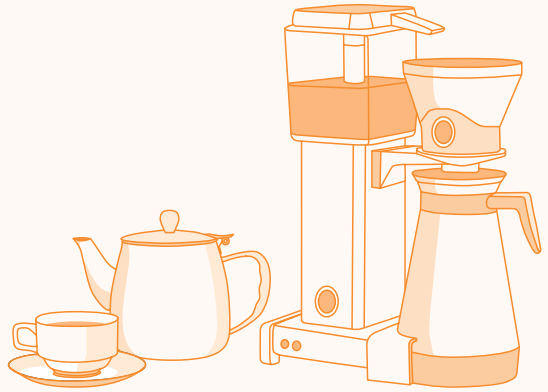

BREW CLEAN

Clean filter coffee brew baskets, servers, air pots and coffee pots with Brew Clean, a powder designed to remove coffee oils and coffee stain, providing a superior clean.

RECOMMENDED FOR*:

American Metal Ware | Animo | Bravilor | Bunn Cecilware | Coffee Queen | Fetco | Grindmaster

AVAILABLE IN:

500g jars (carton code E29389 - 12 jars)

CERTIFICATIONS:



NSF Protocol P156
Commercial Coffee
Equipment Cleaners
—Health and Performance



For Agriculture Use



POLAR CLEAN

Clean cold brew systems with our simple and fast, 2-in-1 product that both cleans and sanitises in one step. Soak components for one hour, then rinse freely, leaving no residue.

Independent laboratory testing confirms Cafetto® Polar Clean kills 99.999% of common food borne bacteria when used according to the in-use instructions.

RECOMMENDED FOR*:

Cold brewing systems | Nitro | Blenders

AVAILABLE IN:

500g jars (carton code E13685 - 12 jars)

*These are the registered trademarks of their respective owners and are not associated.

Cafetto's range of brewer and equipment cleaners can be used to clean filter coffee brew baskets, servers, air pots, coffee pots, teapots and blenders.

They provide a superior clean and sanitation for the removal of coffee and tea stains, oils and tannins that will all affect the quality of a beverage.



BREWER & EQUIPMENT CLEANERS



TEA CLEAN

Remove oils, tea tannin and stains from porcelain, ceramic and glass tea makers, tea pots and tea cups.

Organic, phosphate free and biodegradable, with regular use, helps to control the build-up of lime scale. Tea Clean is quick and easy to use and will help you keep your tea makers looking great.

RECOMMENDED FOR:

Cleaning tea makers and crockery

AVAILABLE IN:

4 x 10g sachets per box (carton code E27220 - 12 boxes)

CERTIFICATIONS:



CHILL

Clean and remove hard water scale from cold coffee systems, soft serve, gelato, blenders and slushie machines with our powder formulated to clean, sanitise and remove water scale.

Contains high levels of sequestrants to soften water and control scale. Non corrosive and micro tested against a range of bacteria, including Listeria and Salmonella.

RECOMMENDED FOR:

Soft serve and gelato machines

AVAILABLE IN:

45g sachets (carton code E13238 - 50 sachets)

500g jars (carton code E11843 - 12 jars)

CERTIFICATIONS:



GRINDER CLEANERS



GRINDER CLEANING

EQUIPMENT LONGEVITY

Cleaning the internal components of a coffee grinder are often overlooked or deemed unnecessary. However, cleaning the internals will remove build up of stale coffee residue, odours and reduce blockages between burrs and chutes.

Cleaning will also improve grinder performance and extend the working life of its burrs.



Unclean Grinder Burrs



After 40g Grinder Clean and light brush

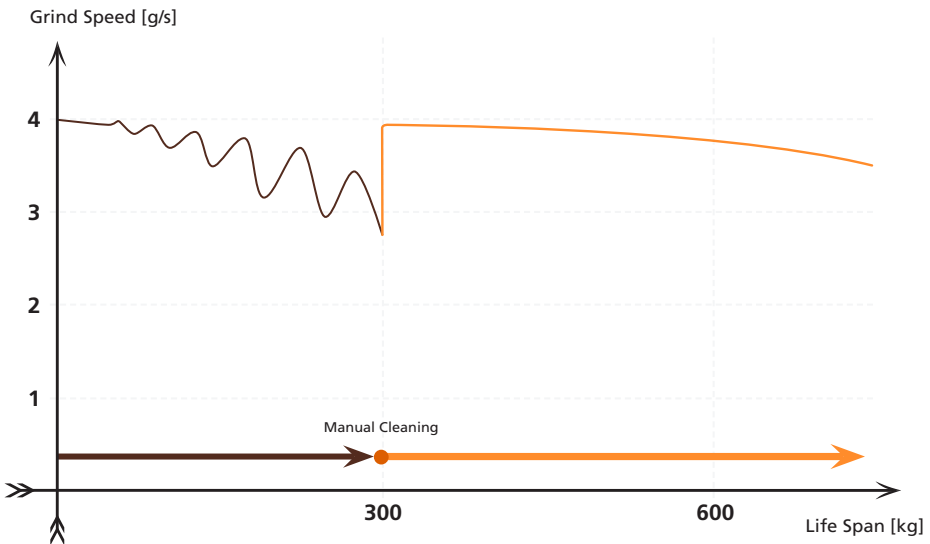

GRINDING WITHOUT REGULAR CLEANING

- Loss of grind speed
- Loss of dosing consistency
- Higher temperature

GRINDING WITH REGULAR CLEANING

- High dosing consistency
- Constant temperature
- Slow decrease of grind speed (life time)

GRINDER CLEANERS



GRINDER CLEAN

Completely food safe, 100% natural and gluten free, Grinder Clean cleans grinder burrs and casings as well as removing flavoured coffee odours.

- No grinder disassembly required
- Removes build-up of stale coffee residue and coffee odours
- Reduces blockages between burrs and internal chambers
- Cleans grinder burrs and casings to improve grinder performance and extend life of grinder burrs
- 100% natural grain based proprietary formula – no binders or chemicals used in processing
- 100% food safe
- Gluten free

RECOMMENDED FOR:

Cleaning grinder burrs and casings

AVAILABLE IN:

3 x 45g sachets per box (carton code E10869 - 12 boxes)

450g jars (carton code E29760 - 12 jars)

CERTIFICATIONS:



Based on the average consumption of coffee in a cafe, we recommend cleaning your grinder twice a week.

CAPSULE MACHINE CLEANERS

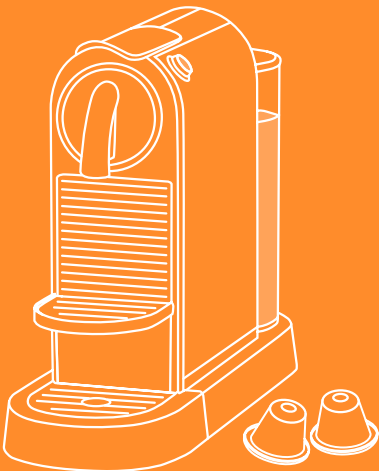

CAPSULE MACHINE CLEANERS

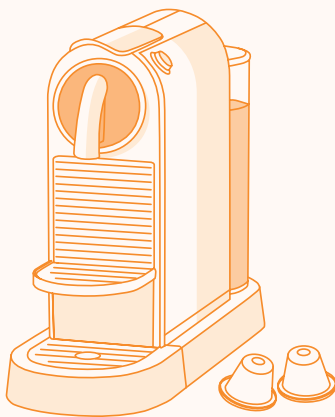

Before – Dirty, tainted water



After – Clean, fresh water

ECO CAPSULE CLEAN

Thoroughly cleans the brewing chamber and delivery spout in Nespresso®* capsule coffee machines.

Eco Capsule Clean is a biodegradable Nespresso®-compatible capsule containing certified organic cleaning powder. Eco Capsule Clean is the world's first espresso machine cleaning powder that is certified organic (OMRI) and (ACO).

- Free from phosphates and GMO ingredients
- 100% biodegradable capsule and recyclable foil
- Removes build-up of old coffee oils for better, fresher tasting coffee
- Completely and rapidly soluble
- Free-rinsing formula leaves no trace of odour

- Reduces risk of machine break-down that can occur as a result of blockages
- Safe for all machine parts
- Use between different beverages to stop cross-contamination of flavours

RECOMMENDED FOR*:

Nespresso

AVAILABLE IN:

6 x 2.5g capsules per box [Not available in all regions]
(carton code E13235 - 20 boxes)

CERTIFICATIONS:



*These are the registered trademarks of their respective owners and are not associated.

GENERAL CLEANING & ACCESSORIES

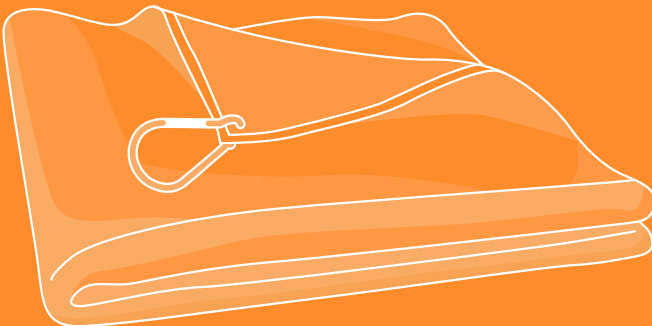

GENERAL CLEANING & ACCESSORIES

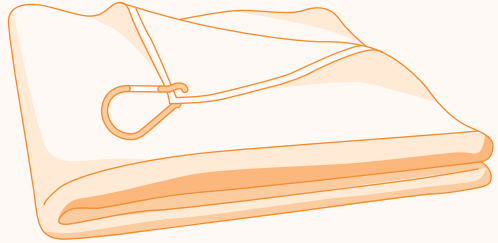

INVERSO

Return shine to milk jugs, crockery and cutlery.

This unique formula of enzymes is versatile removing fat, oil, and grime build up from stainless steel surfaces and accessories, leaving a shiny finish without the scrubbing.

RECOMMENDED FOR:

Milk jugs | Crockery | Cutlery | Brewers
Filters | Stainless steel sinks and benchtops

AVAILABLE IN:

3 x 50g sachets per box (carton code E11935 - 12 boxes)
750g jars (carton code E29916 - 12 jars)

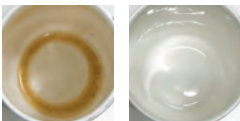

Before

After



SPRAY & WIPE GREEN

Effective on all washable hard surfaces, Cafetto® Spray & Wipe Green leaves a sparkling finish while removing grime effortlessly.

The fragrance-free formula leaves a spotless, streak-free finish.

RECOMMENDED FOR:

Cleaning washable hard surfaces, benchtops,
tabletops, machine exterior

AVAILABLE IN:

Green 750ml bottles (carton code E10299 - 8 bottles)

CERTIFICATIONS:



Maintaining completely clean equipment requires premium cleaning accessories.

Cafetto® offers a range of accessories to support a clean and healthy machine with a focus on simplifying the cleaning process. This includes multi-coloured microfibre cloths and specifically designed brushes for ease of cleaning all machine parts.



CLEANING ACCESSORIES



BLIND FILTER

An essential component for back flushing group heads.

AVAILABLE IN:

53mm (carton code E13792 - 10 filters)

58mm (carton code E23363 - 10 filters)



HAYNES® LUBRI-FILM PLUS

Haynes® Lubri-Film Plus is a heavy duty food grade lubricant with extended performance and low friction properties. The lubricant minimises downtime, extends the life of moving parts and will not dry or gum on equipment.

AVAILABLE IN:

113g (carton code E28262 - 12 tubes)

CERTIFICATIONS:





MICROFIBRE CLOTHS

Premium quality microfibre cloths designed to assist the barista in maintaining complete cleanliness of the espresso machine and its surrounds.

Designed to outperform and outlast conventional kitchen cleaning cloths. Cloth fibres loosen and lift more dust, dirt and liquid. Cafetto® microfibre cloths can be washed up to 400 times.



CAFETTO® BARISTA CLOTH SET

Cloth Set includes:

- 1 x Brown Barista Clip Cloth 30x60cm
- 1 x Green Cleaning Cloth 30x30cm
- 2 x Blue Cleaning Cloth 20x20cm

AVAILABLE IN:

Cloth Set: 1 x Brown, 1 x Green, 2 x Blue
(carton code E23960 - 20 sets)



CAFETTO® BARISTA CLIP CLOTH

Never lose your cloth again! Perfect for the busy barista, this premium microfibre Barista Clip Cloth has a nifty clip to secure the cloth to your belt loop for easy access.

Cloth size: 30x60cm

AVAILABLE IN:

Brown Clip Cloth 30x60cm
(carton code E23987 - 50 cloths)

MICROFIBRE CLEANING CLOTHS



CAFETTO® GREEN CLEANING CLOTH

A multipurpose cloth for cleaning benches and wiping down the machine.

Cloth size: 30x30cm

AVAILABLE IN:

Green Cleaning Cloth 30x30cm
(carton code E23976 - 50 cloths)



CAFETTO® BLUE STEAM WAND CLOTH

A small cloth that fits the palm of your hand, the perfect size for cleaning the steam wand, keeping dairy away from other parts of the machine.

Cloth size: 20x20cm

AVAILABLE IN:

Blue Steam Wand Cloth 20x20cm
(carton code E23969 - 50 cloths)



CLEANING BRUSH ACCESSORIES



SWIVEL HEAD CLEANING BRUSH

Maintain your group heads and shower screens with this ergonomic, eco-friendly swivel action cleaning brush. Ease the cleaning process with an ergonomic handle designed to assist in getting into every nook and cranny. The brush has been designed with replaceable heads to reduce landfill.

AVAILABLE IN:

Black with Green Brush Head
(carton code E24134 - 25 brushes)

Replacement Brush Heads: 2 Pack
(carton code E25107- 10 sets)



MILK FROTHER BRUSH SET

Clean a broad range of milk frothers with 5 different size brushes and a steam tip cleaning wand.

AVAILABLE IN:

Wire Ring Set (carton code E29048 - 20 sets)



PALLO™ GRINDMINDER

A versatile barista tool encompassing a grinder brush. Brush down the grinder, flip it around and sweep off the counter. The ergonomic handle keeps your hand in a comfortable natural position. Natural food-grade bristles.

AVAILABLE IN:

Black (individual code E29245 - 1 brush)

Replacement Brush: 2 Pack (individual code E23365)



STEAM TIP BRUSH SET

Effectively clean steam wand tips, small ports & jets with our set of five fine brushes. The wire ring set design ensures that you have the full range at your fingertips. Includes sizes: 1.0mm, 1.3mm, 2.0mm, 3.0mm and 5.8mm diameter.

AVAILABLE IN:

Wire Ring Set: 1.0mm, 1.3mm, 2.0mm, 3.0mm, 5.8mm diameter (carton code E29843 - 10 sets)

PRODUCT DIMENSIONS



PRODUCT NAME	SIZE	CARTON CODE	GROSS WEIGHT (KG):	GROSS WEIGHT (LBS):	NET WEIGHT (KG):	NET WEIGHT (LBS):	DIMENSIONS (CM) L X W X H:	DIMENSIONS (IN) L X W X H:	HS CODE:
B30 Tablets	150 x 4 Jars	E29018	2.1	4.6	1.6	4.4	19 x 19 x 15	7.5 x 7.5 x 5.9	340290
Brew Clean	500g x 12 Jars	E29389	7	15.4	6	14.9	27 x 18 x 25	10.6 x 7.1 x 9.8	340290
Chill	45g x 50 Sachets	E13238	2.3	5.1	2.1	4.6	25 x 22 x 14	10.6 x 8.7 x 5.5	340220
	500g x 12 Jars	E11843	7	15.4	6	14.9	27 x 18 x 25	10.6 x 7.1 x 9.8	340290
Eco Capsule Clean	6x2.5g x 20 Boxes	E13235	1.3	2.9	0.9	2	27 x 26 x 17	10.6 x 10.2 x 6.7	340220
Espresso Clean®	18x5g x 12 Boxes	E10253	1.6	3.5	1.1	2.4	21 x 18 x 14	8.3 x 7.1 x 5.5	340290
	500g x 12 Jars	E25121	7.2	15.8	6	14.8	27 x 18 x 25	10.6 x 7.1 x 9.8	340290
	1kg x 12 Jars	E11839	13.6	29.9	12	28.6	43 x 32 x 17	16.9 x 12.6 x 6.7	340290
Espresso Clean® Tablets	150 x 12 Jars	E27893	6	13.2	4.5	12.4	27 x 18 x 25	10.6 x 7.1 x 9.8	340290
EVO®	18x5g x 12 Boxes	E15434	1.6	3.5	1.1	2.4	21 x 18 x 14	8.3 x 7.1 x 5.5	340290
	500g x 12 Jars	E29160	7	15.4	6	14.9	27 x 18 x 25	10.6 x 7.1 x 9.8	340290
	1kg x 12 Jars	E29120	13.7	30.1	12	28.8	43 x 32 x 17	16.9 x 12.6 x 6.7	340290
F20 Tablets	100 x 12 Jars	E29782	3.1	6.8	2.4	6.6	22 x 15 x 22	8.7 x 5.9 x 8.7	340290
	200 x 4 Jars	E29777	2.1	4.4	1.6	4.1	19 x 19 x 15	7.1 x 7.1 x 5.5	340290
Grinder Clean	3x45g x 12 Boxes	E10869	2.0	4.4	1.6	4.1	21 x 18 x 14	8.3 x 7.1 x 5.5	340290
	450g x 12 Jars	E29760	6.5	14.3	5.4	13.5	27 x 18 x 28	10.6 x 7.1 x 11	340590
Inverso	3x50g x 12 Boxes	E11935	2.1	4.4	1.8	4.0	21 x 18 x 14	8.3 x 7.1 x 5.5	340290
	750g x 12 Jars	E29916	10.7	23.5	9	22.2	32 x 43 x 18	12.6 x 16.9 x 7.1	340290
J25 Tabs	40 x 12 Jars	E29941	1.8	4	1.2	3.6	24 x 19 x 10	9.4 x 7.5 x 3.9	340290
LOD Green	1L x 6 Bottles	E25482	7.7	17	6.8	16.7	28 x 19 x 28	11 x 7.5 x 11	340290
	5L x 2 Bottles	E26200	11.3	24.9	10.8	23.8	28 x 20 x 31	11 x 7.7 x 12	340290

PRODUCT DIMENSIONS

PRODUCT NAME	SIZE	CARTON CODE	GROSS WEIGHT (KG):	GROSS WEIGHT (LBS):	NET WEIGHT (KG):	NET WEIGHT (LBS):	DIMENSIONS (CM) L X W X H:	DIMENSIONS (IN) L X W X H:	HS CODE:
LOD Red	1L x 6 Bottles	E12312	7.8	17	6.8	15	28 x 19 x 28	11 x 7.5 x 11	340290
	5L x 2 Bottles	E13673	11.3	24.9	10.8	23.8	28 x 20 x 31	11 x 7.7 x 12	340290
M35 Tablets	150 x 4 Jars	E29840	2.4	5.3	1.8	5	19 x 19 x 15	7.5 x 7.5 x 5.9	340290
MFC® Blue	1L x 6 Bottles	E14005	7.6	16.6	6.7	16.5	28 x 19 x 28	11 x 7.5 x 11	340290
MFC® Green	1L x 6 Bottles	E27885	7.6	16.6	6.8	16.5	28 x 19 x 28	11 x 7.5 x 11	340290
MFC® Red	1L x 6 Bottles	E14220	7.6	16.6	6.2	16.5	28 x 19 x 28	11 x 7.5 x 11	340290
MFC® Powder Blue	12x10g x 12 Boxes	E12177	1.6	3.5	1.5	3.3	21 x 18 x 14	8.3 x 7.1 x 5.5	340290
	500g x 12 Jars	E11840	7.2	15.8	6	14.8	27 x 18 x 25	10.6 x 7.1 x 9.8	340290
MFC® Powder Red	12x10g x 12 Boxes	E11427	1.6	3.5	1.5	3.3	21 x 18 x 14	8.3 x 7.1 x 5.5	340290
	500g x 12 Jars	E11842	7.2	15.8	6	14.8	27 x 18 x 25	10.6 x 7.1 x 9.8	340290
MFC® Tabs Blue	62 x 12 Jars	E10297	8.1	17.8	5.6	16.7	27 x 18 x 28	10.6 x 7.1 x 11	340290
MFC® Tabs Red	62 x 12 Jars	E10298	8.1	17.8	5.6	16.7	27 x 18 x 28	10.6 x 7.1 x 11	340290
MLC	1L x 6 Bottles	E18048	7.1	15.5	6.4	15.2	26 x 18 x 24	10.2 x 7.1 x 9.4	340290
N10 Tablets	50 x 24 Jars	E29983	2	4.4	1.2	4.3	24 x 18 x 12	9.4 x 7.1 x 4.7	340290
Organic Descaler	250ml x 12 Bottles	E27434	3.8	8.4	3.4	7.7	23 x 17 x 21	9.1 x 6.7 x 8.3	340220
Polar Clean	500g x 12 Jars	E13685	7.2	15.8	6	13.2	27 x 18 x 25	10.6 x 7.1 x 9.8	340290
Restore	25g x 70 Sachets	E14244	1.5	3.3	1.3	2.9	21 x 18 x 14	8.3 x 7.1 x 5.5	340290
	4x25g x 12 Boxes	E28303	1.9	4.1	1.2	3.5	26 x 22 x 14	10.6 x 8.7 x 5.5	340220
	1kg x 4 Jars	E27889	4.5	9.9	4	9.6	21 x 21 x 16	8.3 x 8.3 x 6.3	340290
S15 Tablets	8 x 15 Blister Packs	E25570	0.4	0.9	0.2	0.8	21 x 14 x 6	8.3 x 5.5 x 2.4	340220
	60 x 12 Jars	E29920	1.5	3.3	1.1	2.9	24 x 18 x 10	9.4 x 7.1 x 3.9	340290
	100 x 12 Jars	E29736	2.4	5.3	1.8	4.9	22 x 15 x 16	8.7 x 5.9 x 6.3	340290
Spectra	4x25g x 12 Boxes	E12173	1.4	3.1	1.2	2.6	21 x 18 x 14	8.3 x 7.1 x 5.5	340290
	600g x 12 Jars	E18091	7	15.4	6	14.9	27 x 18 x 25	10.6 x 7.1 x 9.8	340290

PRODUCT NAME	SIZE	CARTON CODE	GROSS WEIGHT (KG):	GROSS WEIGHT (LBS):	NET WEIGHT (KG):	NET WEIGHT (LBS):	DIMENSIONS (CM) L X W X H:	DIMENSIONS (IN) L X W X H:	HS CODE:
Spray & Wipe Green	750ml x 8 Bottles	E10299	6.4	14.1	6	13.2	28 x 23 x 25.5	11 x 9 x 10	340290
Tea Clean	4x10g x 12 Boxes	E27220	0.9	1.9	0.4	1.5	21 x 18 x 12	8.3 x 7.1 x 4.7	340220
TEVO® Tablets	8 x 40 Blister Packs	E11927	0.5	1.1	0.4	0.9	24 x 18 x 12	9.4 x 7.1 x 4.7	340220
	Mini 100 x 12 Jars	E10335	2.4	5.3	1.8	4.9	22 x 15 x 16	8.7 x 5.9 x 6.3	340290
	Maxi 150 x 12 Jars	E27852	6	13.2	4.5	11.4	27 x 18 x 25	10.6 x 7.1 x 9.8	340290
ACCESSORIES									
Barista Clip Cloth	Brown 30x60cm x 50 Cloths	E23987	6.5	14.3	5.5	12.1	61 x 24 x 25	24 x 9.5 x 9.8	630710
Barista Cloth Set	3 Cloth Box Set x 20 Sets	E23960	4.6	10.1	4.1	9	42 x 36 x 38	16.5 x 14.2 x 15	630710
Blind Filter	53mm x 10 Filters	E13792	0.2	0.4	0.2	0.4	15 x 23 x 7	5.9 x 9 x 2.7	841990
	58mm x 10 Filters	E23363	0.2	0.4	0.2	0.4	21 x 30 x 10	8.2 x 11.8 x 3.9	841990
Cleaning Cloth	Green 30x30cm x 50 Cloths	E23976	2.7	6	1.9	4.2	46 x 25 x 21	18.1 x 9.8 x 8.3	630710
Haynes® Lubri-Film Plus	113g x 12 Tubes	E28262	1.6	3.5	1.5	3.3	17 x 14 x 15	6.7 x 5.3 x 5.9	271019
Milk Frother Brush Set	5 Brush Wire Ring Set x 20 Sets	E29048	0.1	0.2	0.1	0.2	18 x 13 x 19	7.1 x 7.5 x 5.1	960310
Pallo™ Grindminder	Black Brush	E29245	3.4	0.1	3	0.1	26 x 8 x 2	10.3 x 3.1 x 0.8	960390
	Replacement Brush x 2 Pack	E23365	0.1	0.1	0.1	0.1	7 x 16 x 3	2.8 x 6.3 x 1.2	960390
Steam Tip Brush	5 Brush Wire Ring Set x 10 Sets	E29843	0.2	0.4	0.1	0.2	30 x 8 x 8	11.8 x 3.1 x 3.1	960310
Steam Wand Cloth	Blue 20x20cm x 50 Cloths	E23969	1.6	3.5	0.9	2	25 x 19 x 28	9.6 x 7.5 x 11	630710
Swivel Head Cleaning Brush	Black with Green Brush Head x 25 Brushes	E24134	1.5	3.3	1.2	2.6	31 x 16 x 25	12.2 x 6.1 x 9.8	960310
	Replacement Brush Head x 2 Pack	E25107	0.2	0.4	0.1	0.2	23 x 23 x 5	9 x 9 x 1.9	960310



AUS 1300 364 440 NZ 0800 772 227 USA 206 462 5212

SG 800 616 3122 EU +44 20 7193 7370 International +61 8 8245 6901

Email: enquiry@cafetto.com | europe@cafetto.com

www.cafetto.com

Cafetto®, EVO®, Espresso Clean®, MFC® and TEVO® are all registered trademarks