

014

# PARTS BOOK

FOR

## BROTHER MA4-B581

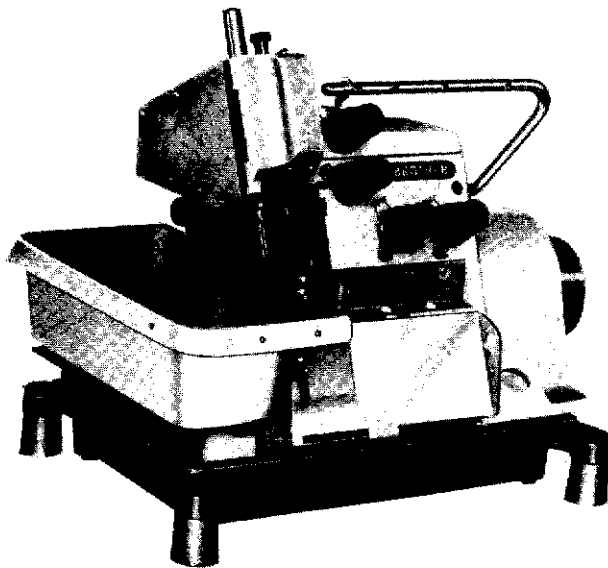

P581102

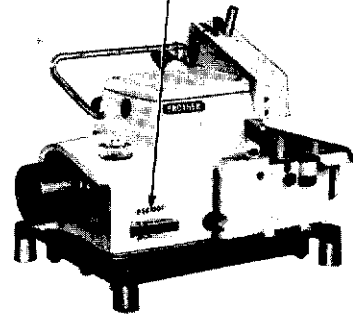

Safety Stitch Sewing Machine

**BROTHER INDUSTRIES, LTD.**

**NAGOYA, JAPAN**

## How to use the parts book

1. This parts book can be used for ordering of the parts of the machine whose plate number is same as shown on the upper cover of the book (or correction sheet).
2. Those pages from A~G·Z·Y on this parts catalogue show all the parts for MA4-B581-061-○.
3. When the column for the parts number or parts assembly number is  · 000000-0-00 please refer to the different parts list on the page 24.
4. When the column for the parts number is , the parts can not be supplied. But when the parts number is shown in the column, please order the parts by the parts assembly number so that can be arranged in the from of assembled parts.
5. After Page 8, please refer to the different parts list on the page 24.

## CONTENTS

<p>A. 061-○(Thin) ..... 1 Machin Body</p> <p>B. 061-○(Thin) ..... 2 Crank Shaft and Needle Bar Mechanism</p> <p>C. 061-○(Thin) ..... 3 Looper Mechaniam</p> <p>D. 061-○(Thin) ..... 4 Looper for Double Chain Stitch</p> <p>E. 061-○(Thin) ..... 5 Feed Mechanism</p> <p>F. 061-○(Thin) ..... 6 Knives and Presser Foot Mechanism</p> <p>G. 061-○(Thin) ..... 7 Threading</p> <p>K. 062-○ Needle Width 2mm ..... 8 (Thin)</p> <p>L. 063-○ Needle Width 3mm ..... 8 (Thin, Medium)</p> <p>M. 064 ○ Needle Width 3mm ..... 9 (Thin, Medium)</p> <p>N. 065-○ Needle Width 5mm ..... 10 (Medium, Heavy)</p> <p>P. 066-○ Needle Width 5mm ..... 11 (Medium, Heavy)</p> <p>Q. 067-○ Needle Width 2mm ..... 12 (Thin, Medium)</p> <p>R. 069-○ Needle Width 3mm ..... 13 (Thin, Medium)</p>	<p>S. 071-○ Needle Width 5mm ..... 14 (Medium, Heavy)</p> <p>T. 073-○ Needle Width 2mm ..... 15 (Thin, Medium Ruffling (W/Piping))</p> <p>U. 075-○ Needle Width 3mm ..... 16 (Thin, Medium Ruffling (W/Piping))</p> <p>V. 077-○ Needle Width 5mm ..... 17 (Thin, Medium Ruffling (W/Piping))</p> <p>W. 081-○ Needle Width 3mm ..... 18 (Thin, Medium Taping)</p> <p>W. 087-○ Needle Width 5mm ..... 19 (Extra Heavy)</p> <p>a. 089-○ Needle Width 3mm ..... 20 (Thin, Medium Binding)</p> <p>b. 092-○ Needle Width 5mm ..... 21 (Extra Heary)</p> <p>x. Cord Guide ..... 22</p> <p>z. Machin Head Plate and Spool Stand ..... 22</p> <p>Y. Accessories ..... 23</p> <p>Different Parts List ..... 24</p> <p>INDEX ..... 30</p>
---	--

# A. 061-(Thin) Machine Body

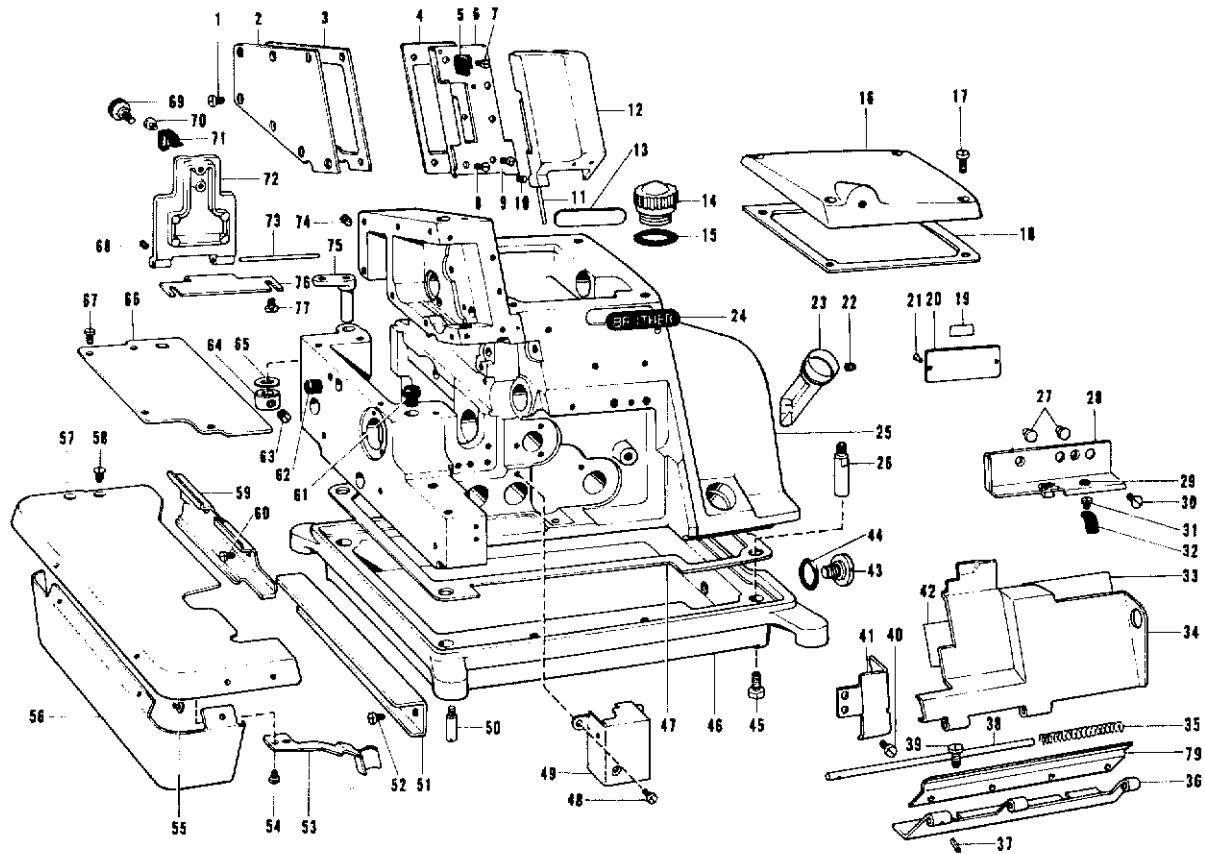

Ref. No.	Name of Parts	Q'ty	Parts No.	Assembly No.	Ref. No.	Name of Parts	Q'ty	Parts No.	Assembly No.
A-1	Screw	7	009680-7-14		A-40	Screw	2	009670-6-12	
A-2	Cover for Needle Driving Mechanism	1	148067-0-01		A-41	Front Cover Guide	1	148103-0-01	
A-3	Face Plate Packing	1	148068-0-00		A-42	Looper Threading Level	1	147943-0-01	
A-4	Face Plate Packing	1	148075-0-00		A-43	Screw	1	110641-0-01	
A-5	Stopper Spring	1	140041-0-01		A-44	Packing	1	109203-0-01	
A-6	Face Plate	1	148074-0-01		A-45	Bolt	4	017771-6-12	
A-7	Screw	1	009670-6-12		A-46	Oil Reservoir	1	148087-0-01	
A-8	Screw	1	102843-0-04		A-47	Packing	1	148088-0-00	
A-9	Screw	1	009670-6-12		A-48	Screw	2	009670-6-12	
A-10	Screw	1	146427-0-01		A-49	Inside Cover	1	148078-0-01	
A-11	Pin for Face Plate	1	146426-0-00		A-50	Set Pin for Cushion	4	140077-0-01	
A-12	Face Plate Cover	1	148073-0-01		A-51	Frame Hanger	1	148090-0-01	
A-13	Number Level (P)	1			A-52	Screw	3	009680-7-12	
A-14	Cap for Oil Feeding Hole	1	146421-0-00		A-53	Stopper Spring for Cloth Plate	1	148304-0-01	
A-15	Packing	1	113589-0-01		A-54	Screw	2	009670-6-12	
A-16	Top Cover	1	148065-0-01		A-55	Screw	3	106568-0-01	
A-17	Screw	4	009681-2-12		A-56	Cloth Plate lower	1	148083-0-01	
A-18	Packing	1	148066-0-00		A-57	Cloth Plate	1	148082-0-01	
A-19	Level	1			A-58	Screw	2	100032-0-03	
A-20	Model Plate 581	1			A-59	Cloth Guide (L)	1	148089-0-01	
A-21	Model Plate Pin	2			A-60	Screw	2	009670-6-12	
A-22	Screw	1	014680-4-22		A-61	Oil Cap	1	148077-0-01	
A-23	Oil Gauge	1	148084-0-01		A-62	Oil Cap	1	146315-0-00	
A-24	Name Plate	1			A-63	Screw	2	101706-0-01	
A-25	Machine Body	1			A-64	Set Collar	1		181969-0-03
A-26	Machine Body Leg	4	148085-0-01		A-65	Washer	1	141183-0-00	
A-27	Oil Cap	2	111865-0-01		A-66	Cover	1	148076-0-01	
A-28	Supporter for Front Cover	1			A-67	Screw	4	009670-6-12	
A-29	Thread Bushing	2	146924-0-00	146444-0-01	A-68	Screw	1	146427-0-01	
A-30	Screw	2	117160-0-01		A-69	Screw	1	106120-0-02	
A-31	Screw	1	009670-4-12		A-70	Screw	1	009670-6-12	
A-32	Stopper Spring for Front Cover	1	146446-0-01		A-71	Stopper Spring	1	148072-0-01	
A-33	Threading Diagram	1	148104-0-01		A-72	Cover for Feed Mechanism (B)	1	148069-0-01	
A-34	Front Cover	1			A-73	Hinge Shaft	1	148071-0-00	
A-35	Spring	1	146442-0-01		A-74	Screw	2	013760-6-12	
A-36	Front Cover Hinge	1	146440-0-01		A-75	Cloth Plate Supporter	1	143374-0-01	
A-37	Pin	1	047140-8-42	148987-0-01	A-76	Feed Mechanism Cover Hinge	1	148070-0-01	
A-38	Front Cover Hinge Shaft	1	146441-0-00		A-77	Screw	2	009680-7-12	
A-79	Hinge Cover	1	148984-0-01		A-78	Packing	1	148859-0-00	
A-39	Screw	2	107407-0-03						

# B. Crank Shaft and Needle Bar Mechanism

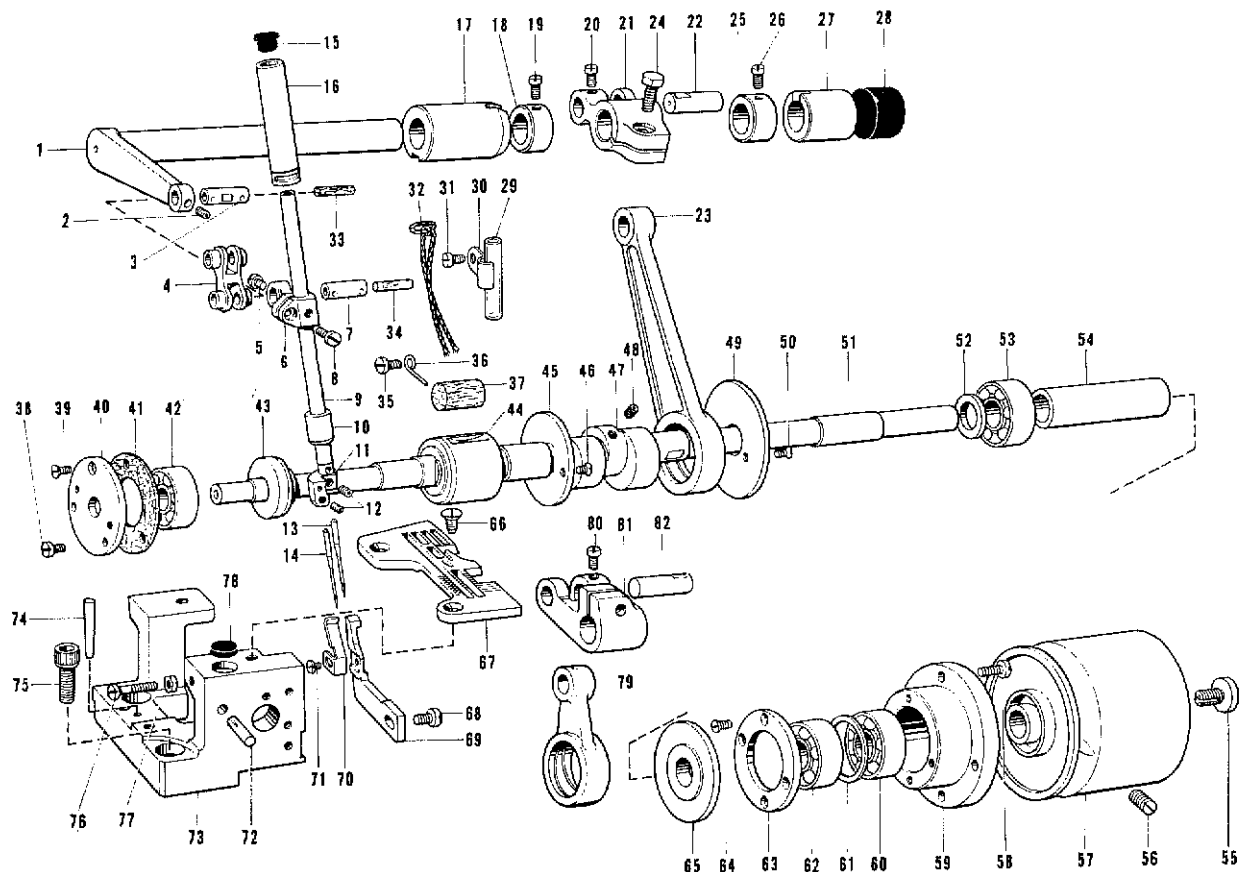

Ref. No.	Name of Parts	Q'ty	Parts No.	Assembly No.	Ref. No.	Name of Parts	Q'ty	Parts No.	Assembly No.
B-1	Needle Bar Crank Shaft	1		148269-0-01	B-37	Felt	1	112754-0-01	
B-2	Screw	1	146427-0-01		B-38	Screw	2	009670-8-12	
B-3	Needle Bar Link Shaft	1			B-39	Screw	1	102538-0-02	
B-4	Needle Bar Link	1			B-40	Bearing Cap	1	146472-0-01	
B-5	Screw	1	009669-4-12		B-41	Packing	1	143312-0-00	
B-6	Needle Bar Clamp	1			B-42	Bearing 6000	1	072600-0-00	
B-7	Needle Bar Link Shaft	1			B-43	Bushing	1	148086-0-00	
B-8	Screw	1	009670-8-12		B-44	Crank Shaft Outer Bushing (L) Assembly	1	148373-0-00	
B-9	Needle Bar	1	146483-0-01		B-45	Looper Connecting Rod Stopper Guide L	1	148225-0-01	
B-10	Needle Bar Bushing (D)	1	146486-0-00		B-46	Screw	2	102843-0-04	
B-11	Needle Clamp 2	1		B-48	Screw	2	148857-0-01		
B-12	Screw	2	146427-0-01	B-49	Looper Connecting Rod Stopper Guide R	1	148205-0-01		
B-13	Needle DC x 1	1	112297-0-11	B-50	Screw	2	102843-0-04		
B-14	Needle DM x 13	1	140104-0-11	B-51	Crank Shaft	1	148113-0-01		
B-15	Cap	1	114255-0-02	B-52	Spacer	1	148112-0-00		
B-16	Needle Bar Bushing (U)	1	148123-0-01	B-53	Bearing 6001	1	072600-1-00		
B-17	Needle Shaft Bushing (Left)	1	148121-0-00	B-54	Collar L	1	148111-0-00		
B-18	Set Collar	1	140092-0-01	B-55	Cap Screw	1	140180-0-01		
B-19	Screw	2	100366-0-01	B-56	Screw	2	013761-4-10		
B-20	Screw	1	100366-0-01	B-57	Pully	1	140085-0-03		
B-21	Needle Arm Driving Lever	1		B-58	Screw	4	009681-0-12		
B-22	Pin	1		B-59	Thrust Washer	1	110670-0-00		
B-23	Needle Arm Driving Crank Rod	1		B-60	Bearing 6001	1	072600-1-00		
B-47	Needle Bar Upper Knife Eccentric Cam	1		B-61	Thrust Washer	1	110672-0-00		
B-79	Pin	1		B-62	Bearing 6001	1	072600-1-00		
B-80	Upper Knife Driving Lever	1		B-63	Bearing Cover	1	110673-0-00		
B-81	Screw	1	100366-0-01	B-64	Screw	4	107244-0-01		
B-82	Upper Knife Driving Rod	1		B-65	Oil Rejector	1	140084-0-00		
B-24	Bolt	1	017761-6-12	B-66	Screw	2	100032-0-03		
B-25	Set Collar	1	140092-0-01	B-67	Needle Plate	1			
B-26	Screw	2	100366-0-01	B-68	Screw	1	009680-7-12		
B-27	Needle Shaft Bushing (Right)	1	148120-0-00	B-69	Chain Stich Needle Guard (B)	1	148126-0-01		
B-28	Oil Cap 20.30 x 10	1	140066-0-01	B-70	Chain Stich Needle Guard (F)	1	148125-0-01		
B-29	Vinil Tube	1	146644-0-00	B-71	Screw	1	009669-4-12		
B-30	Tube Holder	1	148315-0-01	B-72	Pin	1	117608-0-01		
B-31	Screw	1	009680-7-12	B-73	Needle Plate Support Bracket	1	148124-0-01		
B-32	Wick	1	118768-0-01	B-74	Pin 3.5 x 24	1	107351-0-01		
B-33	Felt	1	147691-0-00	B-75	Bolt	2	018061-6-22		
B-34	Felt	1	147691-0-00	B-76	Screw	1	009671-4-12		
B-35	Screw	1	009680-7-12	B-77	Nut	1	021670-2-02		
B-36	Felt Holder	1	148247-0-01	B-78	Cloth Plate Cushion (B)	1	111486-0-01		

# C. 061-(Thin) C. Looper Mechanism

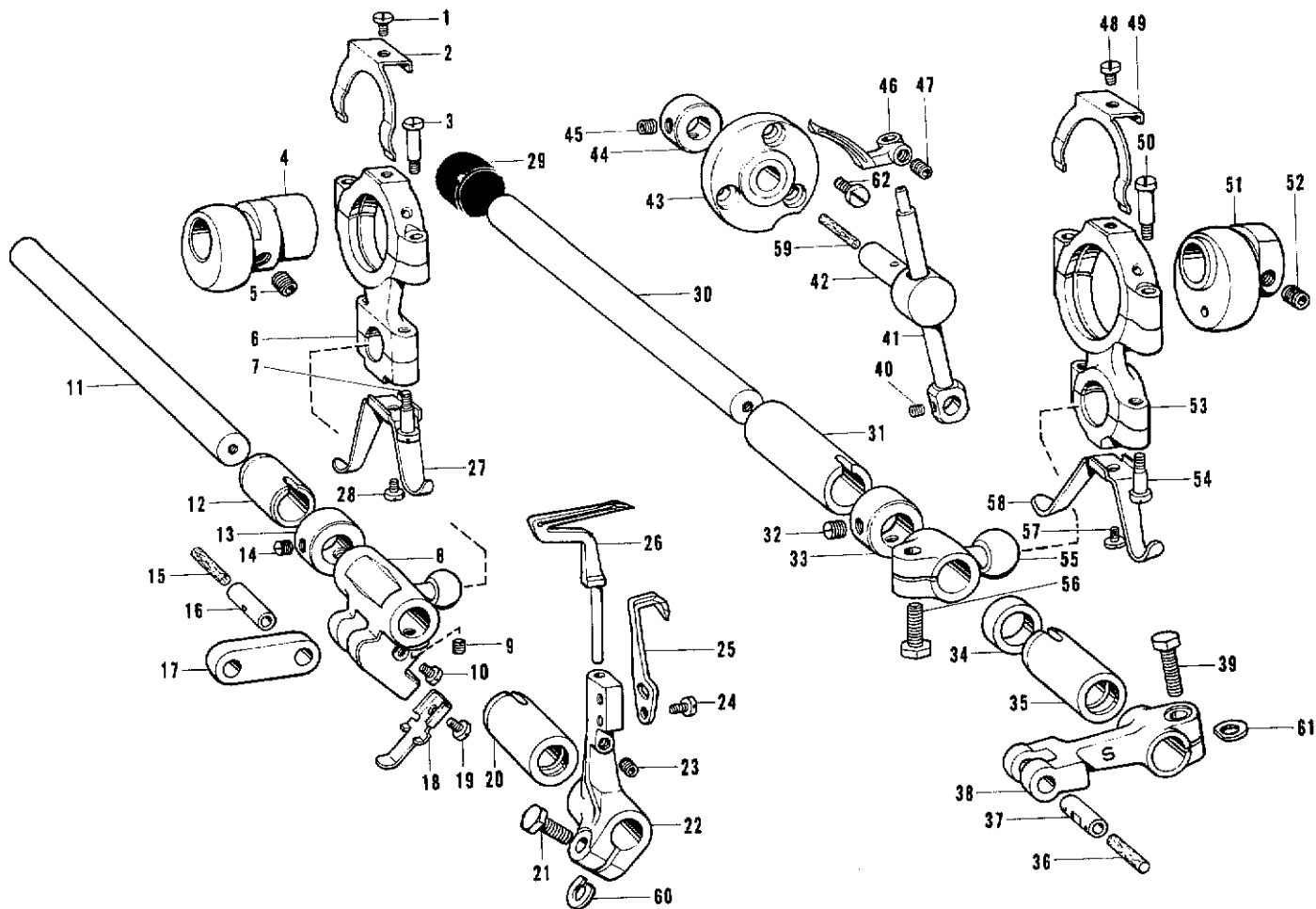

Ref. No.	Name of Parts	Q'ty	Parts No.	Assembly No.	Ref. No.	Name of Parts	Q'ty	Parts No.	Assembly No.
C-1	Screw	1	009670-5-12		C-31	Bushing	1	148207-0-00	
C-2	Looper Connecting Rod Stopper	1	148224-0-01		C-32	Screw	2	100260-0-01	
C-4	Under Looper Eccentric Cam	1		181629-0-01	C-33	Set Collar	1	146581-0-01	
C-5	Screw	2	148857-0-01		C-34	Thrust Collar	1	148208-0-01	
C-3	Screw	2	142590-0-01		C-35	Bushing	1	144031-0-00	
C-6	Looper Connecting Rod	1		181630-0-01	C-36	Wick	1	108809-0-01	
C-7	Screw	2	142590-0-01		C-37	Over Looper Holder Pin	1		
C-8	Under Looper Connecting Lever	1		148230-0-01	C-38	Over Looper	1		
C-9	Screw	2	014680-4-22		C-61	Spacer	1	148783-0-01	
C-10	Screw	1	144458-0-01		C-39	Bolt	1	017761-6-12	
C-11	Under Looper Shaft	1	148226-0-01		C-40	Screw	1	146427-0-01	148209-0-01
C-12	Under Looper Shaft Bushing (B)	1	148227-0-00		C-41	Over Looper Holder	1		
C-13	Set Collar	1		180323-0-01	C-42	Over Looper Holder Guide Block	1		
C-14	Screw	2	013760-6-12		C-43	Over Looper Holder Guide Base	1		
C-15	Wick	1	143444-0-01		C-44	Set Collar	1		
C-16	Under Looper Holder Pin	1	148232-0-01		C-45	Screw	2	014680-4-22	
C-17	Chain Stitch Link	1	148242-0-01		C-46	Over Looper	1		147934-0-01
C-18	Oil Jumping Plate	1	148252-0-01		C-47	Screw	1	014680-4-22	
C-19	Screw	1	009670-5-12		C-48	Screw	1	009670-5-12	
C-20	Under Looper Shaft Bushing (F)	1	148228-0-00		C-49	Looper Connecting Rod Stopper	1	148204-0-01	
C-21	Bolt	1	017751-4-12		C-51	Over Looper Eccentric Cam	1		181628-0-01
C-22	Under Looper Holder	1	146617-0-01		C-52	Screw	2	148857-0-01	
C-60	Spacer	1	148782-0-01		C-50	Screw	2	142658-0-01	
C-23	Screw	1	014680-4-22		C-53	Over Looper Connecting Rod	1		181631-0-01
C-24	Screw	2	009670-8-12		C-54	Screw	2	142590-0-01	
C-25	Movable Needle Gaud	1	144127-0-01		C-55	Over Looper	1		148200-0-01
C-26	Under Looper	1	144049-0-01		C-56	Bolt	1	017771-6-12	
C-27	Oil Jumping Plate	1	148251-0-01		C-57	Screw	1	009670-5-12	
C-28	Screw	1	009670-5-12		C-58	Oil Jumping Plate (R)	1	148250-0-01	
C-29	Oil Cap 20.30×66	1	140066-0-01		C-59	Wick	1	148249-0-00	
C-30	Over Looper Shaft	1	148206-0-01		C-62	Screw	3	009680-7-12	

# D. 061-(Thin) Looper for Double Chain Stitch

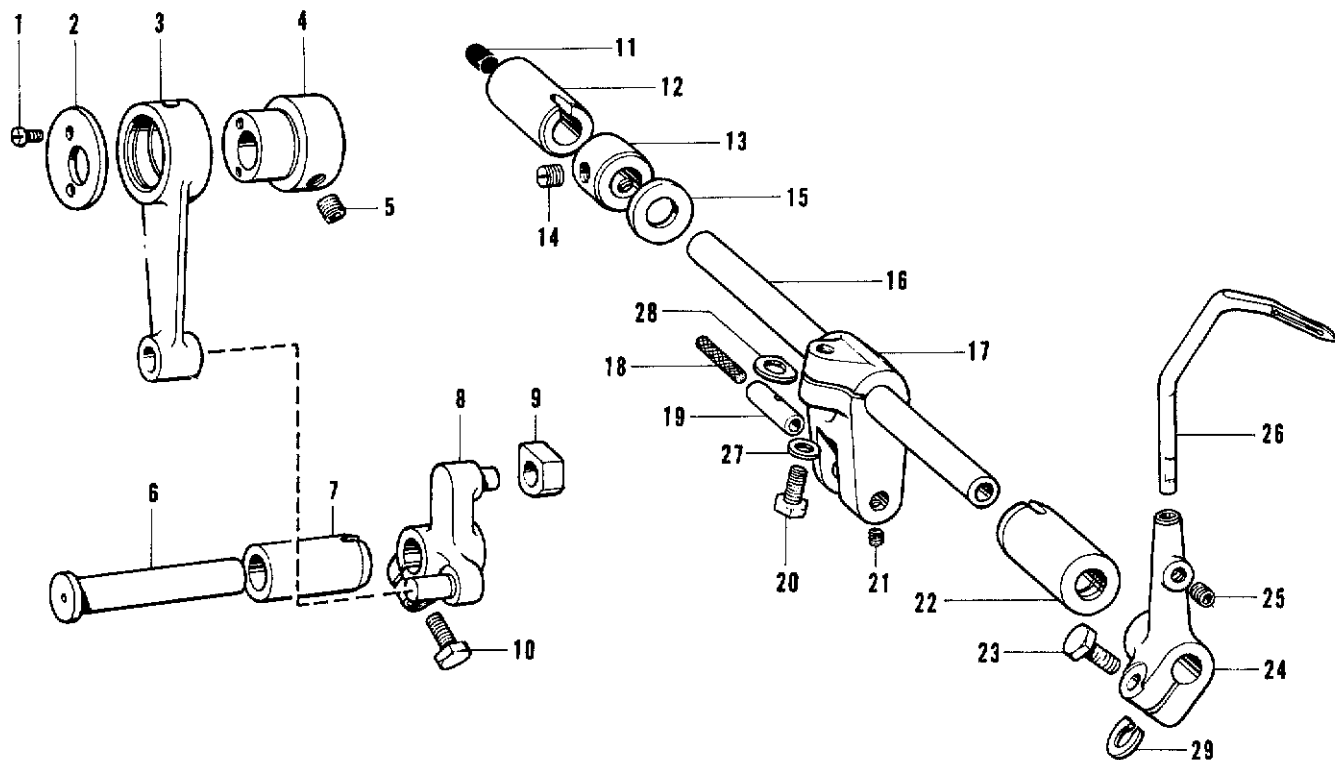

Ref. No.	Name of Parts	Q'ty	Parts No.	Assembly No.	Ref. No.	Name of Parts	Q'ty	Parts No.	Assembly No.
D- 1	Screw	2	009630-6-12		D-16	Longitudinal Feed Shaft	1	148243-0-01	
D- 2	Longitudinal Feed Driving Rod Presser Plate	1	148235-0-01		D-17	Chain Stitch Driving Lever	1	148240-0-01	
D- 3	Longitudinal Feed Driving Rod	1	148234-0-00		D-18	Wick	1	117591-0-01	
D- 4	Longitudinal Eccentric Cam(Right)	1	148233-0-01		D-19	Chain Stitch Driving Lever Shaft	1	148241-0-01	
D- 5	Screw	2	148857-0-01		D-20	Bolt	1	017761-4-12	
D- 6	Longitudinal Feed Lever Shaft	1	148236-0-01		D-21	Screw	1	146427-0-01	
D- 7	Longitudinal Feed Lever Shaft Bushing	1	148237-0-00		D-22	Longitudinal Feed Shaft Bushing B	1	148245-0-00	
D- 8	Feed Lever	1		181668-0-01	D-23	Bolt	1	017751-4-12	
D-10	Bolt	1	017771-4-12		D-24	Chain Stitch Looper Holder	1	146634-0-01	
D- 9	Slide Block	1	140313-0-01		D-25	Screw	1	014680-4-22	
D-11	Oil Cap	1	140327-0-01		D-26	Chain Stitch Looper	1	146635-0-01	
D-12	Bushing (Front)	1	148244-0-00		D-27	Washer	1	025060-1-32	
D-13	Set Collar	1		181995-0-01	D-28	Spacer	1	148783-0-01	
D-14	Screw	2	101706-0-03		D-29	Spacer	1	148782-0-01	
D-15	Thrust Collar	1	148239-0-01						

E. 061-○(Thin)  
E. Feed Mechanism

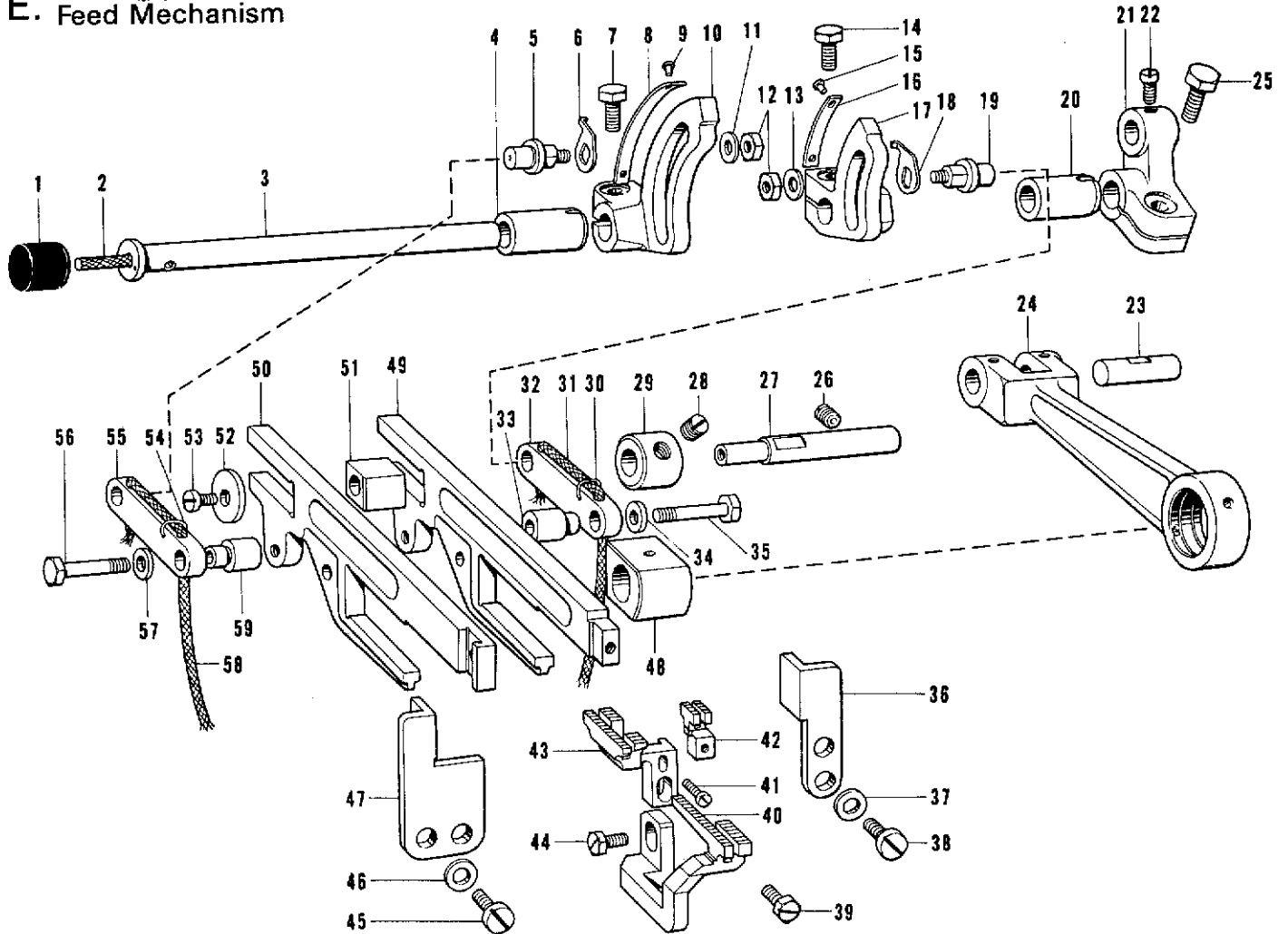

Ref. No.	Name of Parts	Q'ty	Parts No.	Assembly No.	Ref. No.	Name of Parts	Q'ty	Parts No.	Assembly No.
E- 1	Oil Cap 14.30×10	1	140065-0-01		E-31	Wick	1	142674-0-00	
E- 2	Wick	1	148248-0-00		E-32	Feed Link	1	148184-0-00	
E- 3	Feed Shaft	1	148167-0-01		E-33	Feed Link Bushing	1	148185-0-01	
E- 4	Feed Shaft Bushing (L)	1	148168-0-00		E-34	Washer	1	140208-0-01	
E- 5	Feed Link Shaft	1	148181-0-01		E-35	Bolt	1	148186-0-01	
E- 6	Feed Link Indicator Plate L	1	148183-0-01		E-36	Feed Bar Guide (R)	1	148174-0-00	
E- 7	Bolt	1	017761-4-12		E-37	Washer	2	113431-0-02	
E- 8	Indicator Plate	1	148180-0-01		E-38	Screw	2	107407-0-03	
E- 9	Model Plate Pin	2	116231-0-01		E-39	Bolt	1	117516-0-01	
E-10	Differential Feed Arm	1	148179-0-01		E-40	Differential Feed Dog	1	146572-0-01	
E-11	Washer	1	148847-0-01		E-41	Screw	1	009630-8-12	
E-12	Nut	2	148838-0-01		E-42	Chain Feed Dog	1	146577-0-01	
E-13	Washer	1	148847-0-01		E-43	Main Feed Dog	1	146567-0-01	
E-14	Bolt	1	017761-4-12		E-44	Bolt	1	117516-0-01	
E-15	Model Plate Pin	2	116231-0-01		E-45	Screw	2	107407-0-03	
E-16	Indicator Plate	1	148178-0-01		E-46	Washer	2	113431-0-02	
E-17	Main Feed Arm	1	148177-0-01		E-47	Feed Bar Guide (L)	1	148175-0-00	
E-18	Feed Link Indicator Plate (R)	1	148182-0-01		E-48	Feed Lifting Slide Block	1	148173-0-00	148262-0-01
E-19	Feed Link Shaft	1	148181-0-01		E-49	Main Feed Bar	1		148170-0-01
E-20	Feed Shaft Bushing (R)	1	148169-0-00		E-50	Differential Feed Bar	1		
E-21	Feed Arm	1			E-51	Feed Bar Guide Block	1	146547-0-00	
E-22	Screw	1	100366-0-01	148163-0-01	E-52	Slide Plate	1	146549-0-01	
E-23	Pin	1	148166-0-01		E-53	Screw	1	009680-7-12	
E-24	Feed Rod	1			E-54	Steel Wire	1	140774-0-00	
E-25	Bolt	1	017761-4-12		E-55	Feed Link	1	148403-0-00	
E-26	Screw	1	148857-0-01		E-56	Bolt	1	148186-0-01	
E-27	Feed Bar Guide Block Shaft	1	148176-0-01		E-57	Washer	1	140208-0-01	
E-28	Screw	2	101706-0-03	181995-0-01	E-58	Wick	1	142674-0-00	
E-29	Set Collar	1			E-59	Feed Link Bushing	1	148404-0-01	
E-30	Steel Wire	1	140774-0-00						

F. 061-○(Thin)  
F. Knives and Presser Foot Mechanism

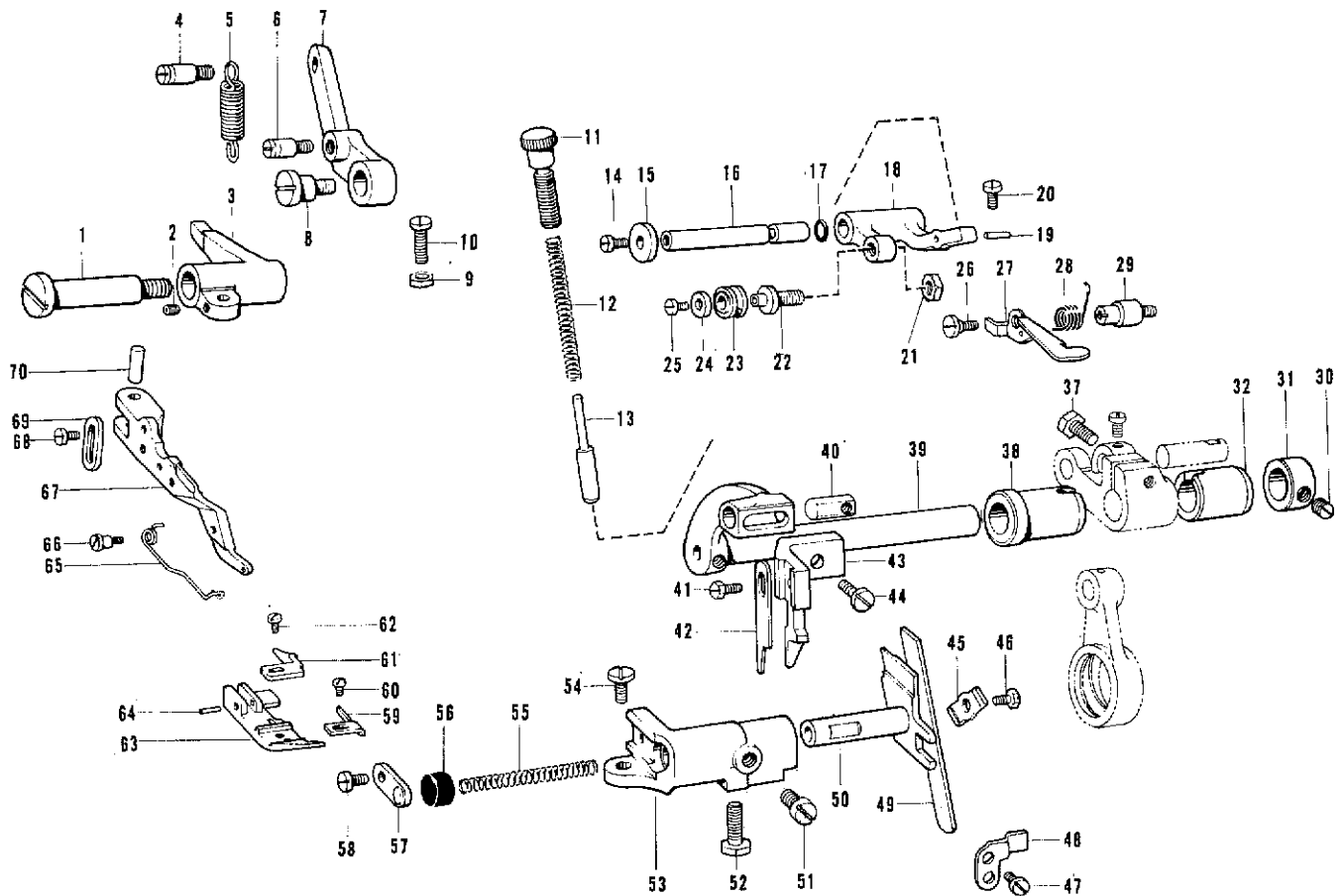

Ref. No.	Name of Part	Q'ty	Parts No.	Assembly No.	Ref. No.	Name of Parts	Q'ty	Parts No.	Assembly No.
F-1	Screw	1	148147-0-01		F-38	Bushing Left	1	148196-0-00	
F-2	Screw	1	146427-0-01		F-39	Upper Knife Driving Arm	1	146580-0-01	
F-3	Presser Foot Supporter	1	148146-0-01		F-40	Nut	1	148281-0-01	
F-4	Spring Hook	1	148144-0-01		F-41	Bolt	1	144075-0-01	
F-5	Spring	1	148145-0-01		F-42	Upper Knife	1	148198-0-01	
F-6	Spring Hook	1	148144-0-01		F-43	Upper Knife Holder	1	144179-0-01	
F-7	Presser Foot Lifter Lever	1	148143-0-01		F-44	Screw	1	107407-0-03	
F-8	Screw	1	141528-0-01		F-45	Lower Knife Holding Plate	1	117515-0-01	
F-9	Nut	1	021680-2-02		F-46	Bolt	1	117516-0-01	
F-10	Screw	1	009681-4-12		F-47	Screw	2	009670-6-12	
F-11	Screw	1	148128-0-01		F-48	Lower Knife Holder Guide	1	146585-0-01	
F-12	Spring	1	148129-0-01		F-49	Lower Knife	1	112436-0-01	
F-13	Pin	1	148130-0-01		F-50	Lower Knife Holder	1	146583-0-01	
F-14	Screw	1	009680-7-12		F-51	Screw	1	107407-0-03	
F-15	Washer	1	148735-0-01		F-52	Bolt	1	017771-6-12	
F-16	Presser Bar Lever Shaft	1	148134-0-01		F-53	Lower Knife Holder Supporter	1	146582-0-01	
F-17	Packing	1	081002-6-70		F-54	Screw	1	102627-0-01	
F-18	Presser Bar Lever	1		148131-0-01	F-55	Spring	1	146584-0-01	
F-19	Roller	1	148133-0-01		F-56	Cap	1	146586-0-00	
F-20	Screw	1	104908-0-01		F-57	Lower Knife Holder Spring Stopper	1	140248-0-01	
F-21	Nut	1	100022-0-05		F-58	Screw	1	009680-7-12	
F-22	Presser Arm Roller Shaft	1		148346-0-01	F-59	Chip Guard (3)	1	142245-0-01	
F-23	Presser Arm Roller	1			F-60	Screw	1	009639-3-12	
F-24	Washer	1	148813-0-01		F-61	Stitch Tongue	1	142244-0-01	
F-25	Screw	1	009670-5-12		F-62	Screw	1	009639-3-12	
F-26	Screw	1	148139-0-01		F-63	Presser Front	1		148155-0-01
F-27	Presser Bar Lifter	1	148137-0-01		F-64	Pin	1	142243-0-01	
F-28	Spring	1	148138-0-01		F-65	Spring	1	142246-0-01	
F-29	Presser Bar Lifter Bracket	1	148136-0-01		F-66	Screw	1	142247-0-01	
F-30	Spring	2	100260-0-01		F-67	Main Presser Arm	1		
F-31	Set Collar	1	146581-0-01		F-68	Screw	2	009669-4-12	
F-32	Bushing Right	1	148197-0-00		F-69	Presser Arm Stopper	1	148148-0-01	
F-37	Bolt	1	017761-6-12		F-70	Pin	1	141393-0-01	



# PARTS BOOK for BROTHER MA4-B581

## Safety Stitch Sewing Machine

☆ Please correct as follows.

G. 061-○(Thin)  
Threading

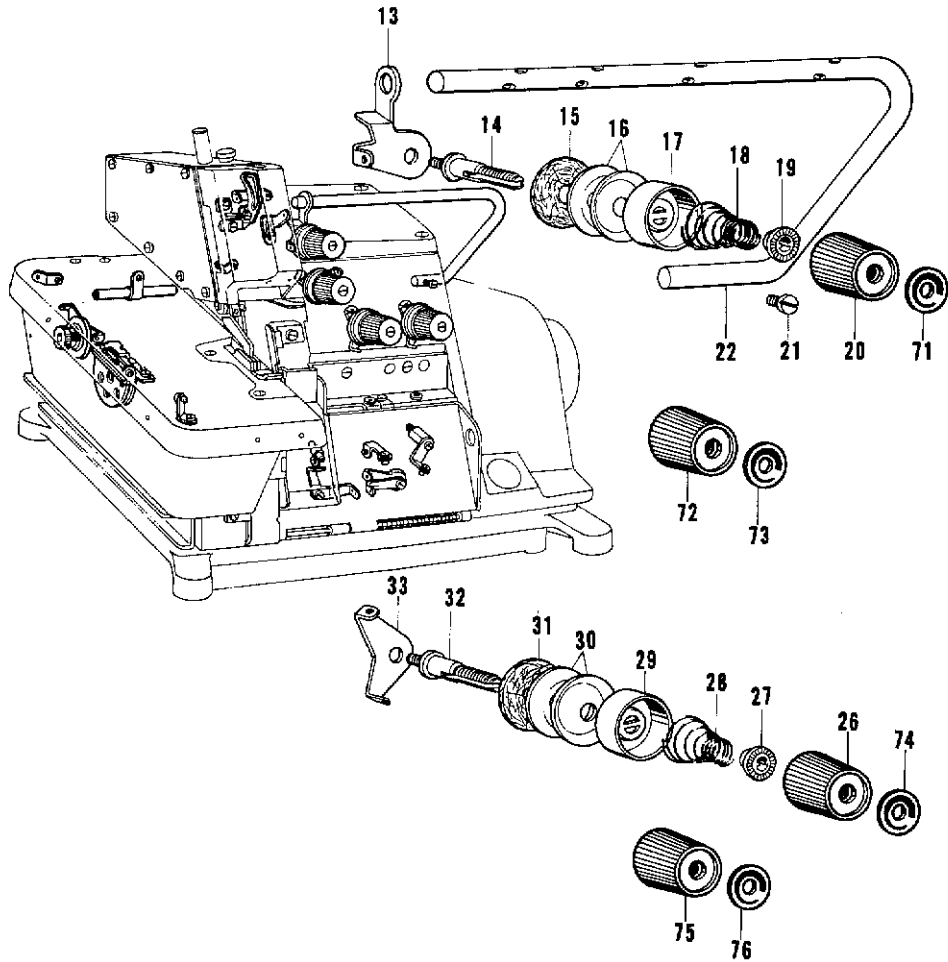

Page	Wrong				Right				
	Ref. No.	Name of Parts	Q'ty	Parts No.	Ref. No.	Name of Parts	Q'ty	Parts No.	Assembly No.
7	G-20	Thread Tension Adjusting Nut	2	144106-0-02	G-20	Thread Tension Adjusting Nut	1	149566-0-01	149568-0-03
					G-71	Color Plate	1	147049-0-03	
					G-72	Thread Tension Adjusting Nut	1	149566-0-01	149568-0-01
					G-73	Color Plate	1	147049-0-01	
	G-26	Thread Tension Adjusting Nut	2	144106-0-02	G-26	Thread Tension Adjusting Nut	1	149566-0-01	149568-0-02
					G-74	Color Plate	1	147049-0-02	
					G-75	Thread Tension Adjusting Nut	1	149566-0-01	149568-0-04
					G-76	Color Plate	1	147049-0-04	



# G. 061-○(Thin) Threading

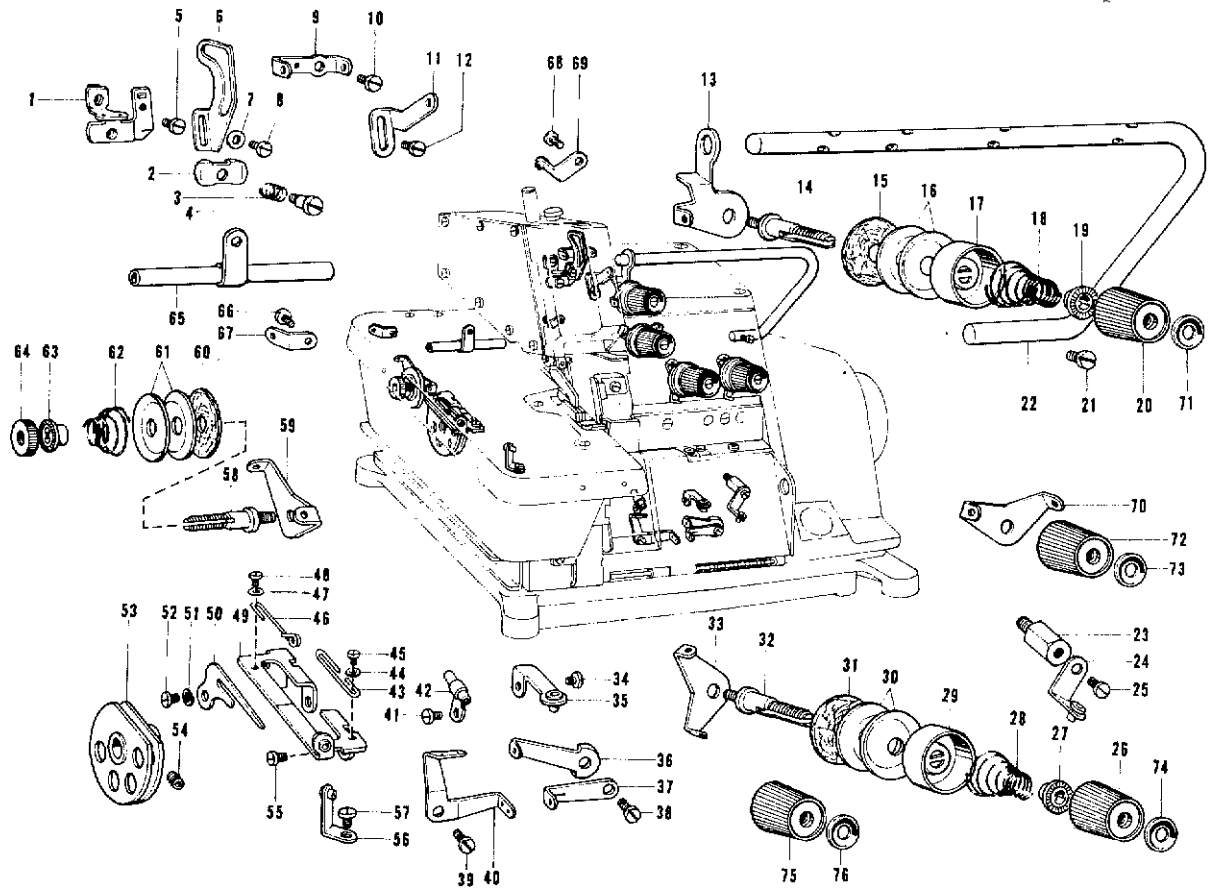

Ref. No.	Name of Parts	Qty	Parts No.	Assembly No.	Ref. No.	Name of Parts	Qty	Parts No.	Assembly No.
G-1	Needle Thread Guide	1	147344-0-01		G-37	Under Looper Thread Take-up (R)	1	146653-0-01	
G-2	Needle Thread Guard	1	112300-0-01		G-38	Screw	1	009670-8-12	
G-3	Needle Thread Guard Spring	1	112299-0-01		G-39	Screw	1	009670-6-12	
G-4	Screw	1	112301-0-01		G-40	Looper Thread Take-up (L)	1	146654-0-01	
G-5	Screw	1	009670-6-12		G-41	Screw	1	122771-0-02	
G-6	Needle Thread Take-up	1	144108-0-01		G-42	Over Looper Thread Guide	1	142669-0-01	
G-7	Washer	1	105248-0-03		G-43	Thread Guide (R)	1	146663-0-01	
G-8	Screw	1	009669-3-12		G-44	Washer	1	025630-2-32	
G-9	Needle Thread Guide (A)	1	143757-0-01		G-45	Screw	1	001630-4-02	
G-10	Screw	1	009670-8-12		G-46	Thread Guide (L)	1	147272-0-01	
G-11	Chain Tension Control Stud	1	148255-0-01		G-47	Washer	1	025630-2-32	
G-12	Screw	1	009670-8-12		G-48	Screw	1	001630-4-02	
G-13	Thread Guide Supporter	1	146649-0-01		G-49	Chain Stitch Looper Base Plate Assembly	1	146928-0-01	
G-14	Looper Thread Tension Control Stud	2	110820-0-01		G-50	Thread Handler	1	146662-0-01	
G-15	Felt	2	110832-0-01		G-51	Washer	1	028350-2-43	
G-16	Tension Disc	4	145446-0-01		G-52	Screw	1	009670-4-12	
G-17	Tension Disc Washer	2	144103-0-02		G-53	Chain Stitch Looper Take-up	1	140290-0-01	
G-18	Spring	2	144104-0-01		G-54	Screw	2	014680-4-22	
G-19	Washer	2	144105-0-00		G-55	Screw	2	009669-4-12	
G-21	Screw	1	009681-4-12		G-56	Under Looper Thread Guide	1	146930-0-01	
G-22	Main Thread Guide	1	148253-0-01		G-57	Screw	1	009670-6-12	
G-23	Thread Guide Holder	1	148254-0-01		G-58	Thread Tension Control Stud	1	147148-0-01	
G-24	Under Looper Thread Guide	1	146926-0-01		G-59	Needle Thread Guide Plate	1	110813-0-01	
G-25	Screw	1	009670-6-12		G-60	Felt	1	110832-0-01	
G-27	Washer	2	144105-0-00		G-61	Tension Disc	2	145446-0-01	
G-28	Spring	2	144110-0-01		G-62	Thread Tension Adjusting Spring	1	147149-0-01	
G-29	Tension Disc Washer	2	144103-0-02		G-63	Washer	1	144105-0-00	
G-30	Tension Disc	4	145446-0-01		G-64	Upper Thread Tension Adjusting Nut	1	105230-0-01	
G-31	Felt	2	110832-0-01		G-65	Thread Guide Pipe Assembly	1	148256-0-01	
G-32	Looper Thread Tension Control Stud	2	110820-0-01		G-67	Thread Guide (A) for Chain Stitch Looper	1	140289-0-01	
G-33	Needle Thread Guide Plate	2	110813-0-01		G-66	Screw	1	009670-6-12	
G-35	Over Looper Thread Guide	1	146929-0-01		G-69	Thread Guide	1	146926-0-01	
G-34	Screw	1	009670-6-12		G-68	Screw	1	009670-6-12	
G-20	Thread Tension Adjusting Nut	1		149568-0-03	G-70	Needle Thread Guide Plate	1	110813-0-01	
G-71	Color Plate	1	147049-0-03	149568-0-03	G-26	Thread Tension Adjusting Nut	1		
G-72	Thread Tension Adjusting Nut	1		149568-0-01	G-74	Color Plate	1	147049-0-02	149568-0-02
G-73	Color	1	147049-0-01	149568-0-01	G-75	Thread Tension Adjusting Nut	1		
G-36	Over Looper Thread Take-up (R)	1	146652-0-01		G-76	Color Plate	1	147049-0-04	149568-0-04

K.062-○ Needle Width 2mm (Thin)

L.063-○ Needle Width 3mm (Thin, medium)

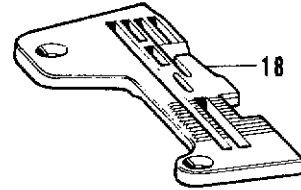
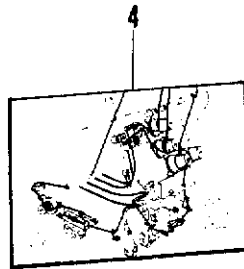
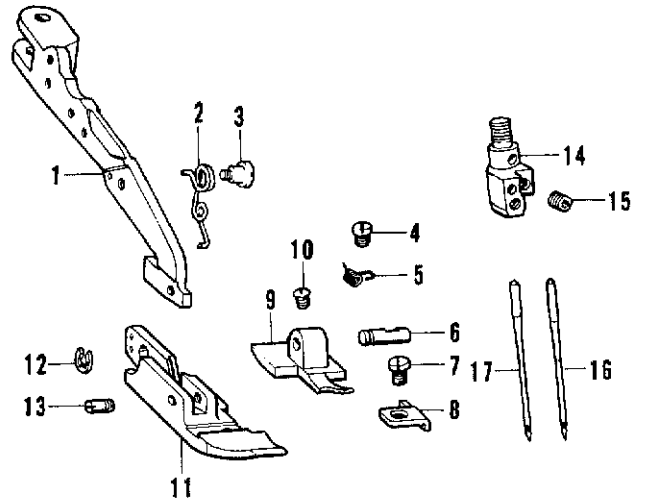
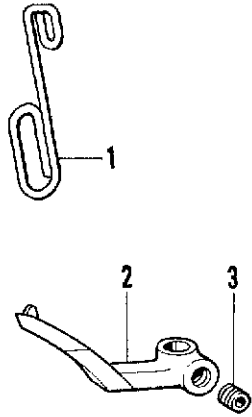

5  
062-

19  
063-

Ref. No.	Name of Parts	Q'ty	Parts No.	Assembly No.
K-1	Needle Thread Take-up	1	142201-0-01	
K-2	Over Spreader	1		147935-0-01
K-3	Screw	1	014680-4-22	
K-4	Threading Diagram	1	148105-0-01	
K-5	Lavel	1		

All other parts except above-mentioned parts are the same as those for 061-○.

Ref. No.	Name of Parts	Q'ty	Parts No.	Assembly No.
L 1	Presser Arm	1		
L 2	Spring	1	148152-0-01	
L 3	Stud Screw	1	146901-0-01	
L 4	Screw	1	122771-0-02	
L 5	Spring	1	146870-0-01	
L 6	Pin	1	146868-0-01	
L 7	Screw	1	105288-0-01	148150-0-01
L 8	Presser Foot (Front)	1	145147-0-01	
L 9	Presser Foot (Rear)	1		
L-10	Screw	1	105288-0-01	
L-11	Presser Foot	1		
L-12	Stop Ring	1	048020-3-42	
L-13	Screw	1	146865-0-01	
L-14	Needle Clamp 3	1		146489-0-01
L-15	Screw	2	146427-0-01	
L-16	Needle DC×1	1	112297-0-14	
L-17	Needle DM×13	1	140104-0-14	
L-18	Needle Plate	1		
L-19	Lavel	1		

All other parts except above-mentioned parts are the same as those for 061-○.

M.064- Needle Width 3mm  
(Thin, medium)

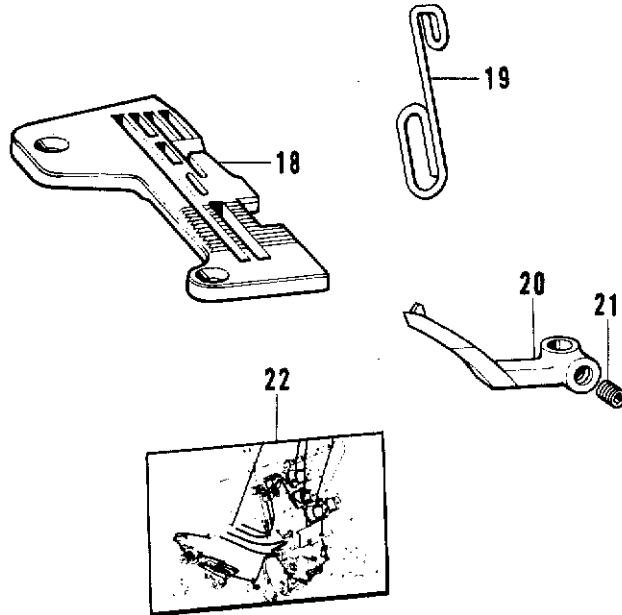
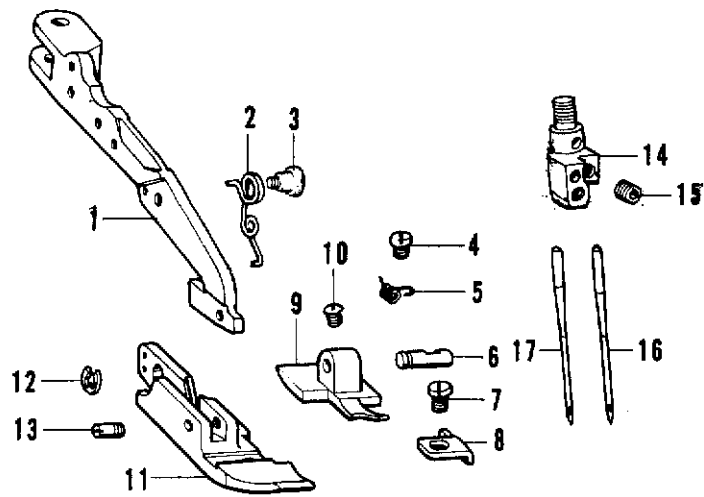

23

064-

Ref. No.	Name of Parts	Q'ty	Parts No.	Assembly No.	Ref. No.	Name of Parts	Q'ty	Parts No.	Assembly No.
M-1	Presser Arm	1		148150-0-01	M-13	Screw	1	146865-0-01	148150-0-01
M-2	Spring	1	148152-0-01		M-14	Needle Clamp 3	1		146489-0-01
M-3	Screw	1	146901-0-01		M-15	Screw	2	146427-0-01	
M-4	Screw	1	122771-0-02		M-16	Needle DC×1	1	112297-0-14	
M-5	Spring	1	146870-0-01		M-17	Needle DM×13	1	140104-0-14	
M-6	Pin	1	146868-0-01		M-18	Needle Plate	1		
M-7	Screw	1	105288-0-01		M-19	Needle Thread Take-up	1	142201-0-01	
M-8	Presser Foot (Front)	1	145147-0-01		M-20	Over Spreader	1		147935-0-01
M-9	Presser Foot (Rear)	1			M-21	Screw	1	014680-4-22	
M-10	Screw	1	105288-0-01		M-22	Threading Diagram	1	148105-0-01	
M-11	Presser Foot	1			M-23	Level	1		
M-12	Stop Ring	1	048020-3-42						

All other parts except above-mentioned parts are the same as those for 061-.

N.065- Needle Width 5mm  
(Medium, heavy)

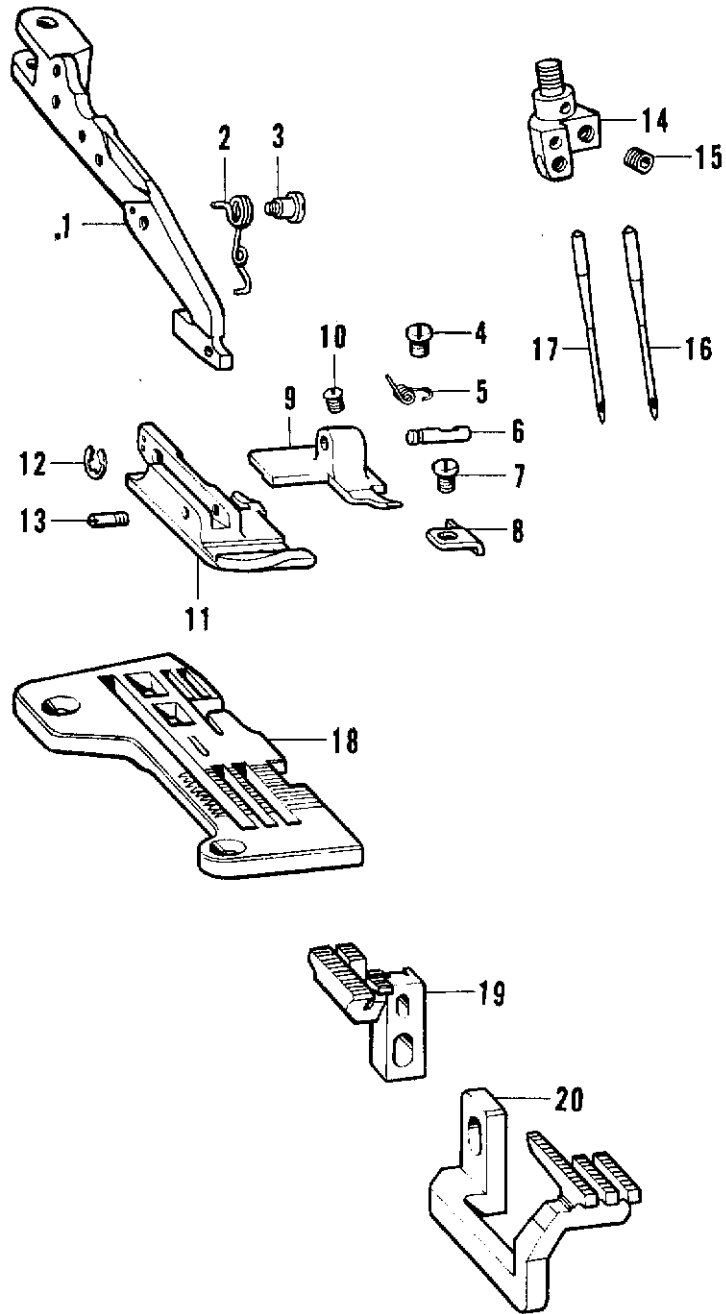

21  
**065-**

Ref. No.	Name of Parts	Q'ty	Parts No.	Assembly No.	Ref. No.	Name of Parts	Q'ty	Parts No.	Assembly No.
N- 1	Presser Arm	1		148153-0-01	N-12	Stop Ring	1	048020-3-42	148153-0-01
N- 2	Spring	1	148152-0-01		N-13	Screw	1	140270-0-01	
N- 3	Stud Screw	1	146901-0-01		N-14	Needle Clamp 5	1		
N- 4	Screw	1	122771-0-02		N-15	Screw	2	146427-0-01	
N- 5	Spring	1	146870-0-01		N-16	Needle DC×1	1	112297-0-16	
N- 6	Pin	1	146868-0-01		N-17	Needle DM×13	1	140104-0-16	
N- 7	Screw	1	105288-0-01		N-18	Needle Plate	1		
N- 8	Presser Foot (Front)	1	145147-0-01		N-19	Main Feet Dog	1	146568-0-01	
N- 9	Presser Foot (Rear)	1			N-20	Differential Feed Dog	1	146573-0-01	
N-10	Screw	1	105288-0-01		N-21	Level	1		
N-11	Presser Foot	1							

All other parts except above-mentioned parts are the same as those for 061-.

P. 066- Needle Width 5mm  
(Medium, heavy)

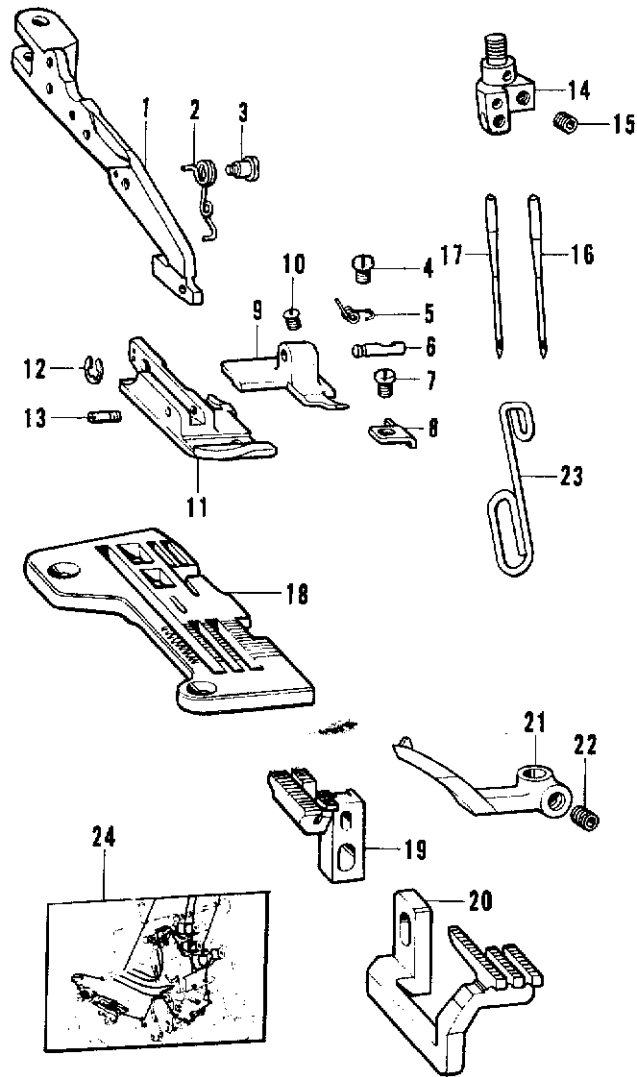

Ref. No.	Name of Parts	Q'ty	Parts No.	Assembly No.	Ref. No.	Name of Parts	Q'ty	Parts No.	Assembly No.
P-1	Presser Arm	1		148153-0-01	P-14	Needle Clamp 5	1		146491-0-01
P-2	Spring	1	148152-0-01		P-15	Screw	2	146427-0-01	
P-3	Stud Screw	1	146901-0-01		P-16	Needle DC×1	1	112297-0-16	
P-4	Screw	1	122771-0-02		P-17	Needle DM×13	1	140104-0-16	
P-5	Spring	1	146870-0-01		P-18	Needle Plate	1		
P-6	Pin	1	146868-0-01		P-19	Main Feed Dog	1	146568-0-01	
P-7	Screw	1	105288-0-01		P-20	Differential Feed Dog	1	146573-0-01	
P-8	Presser Foot (Front)	1	145147-0-01		P-21	Over Spreader	1		147935-0-01
P-9	Presser Foot (Rear)	1			P-22	Screw	1	014680-4-22	
P-10	Screw	1	105288-0-01		P-23	Needle Thread Take-up	1	142201-0-01	
P-11	Presser Foot	1			P-24	Threading Diagram	1	148105-0-01	
P-12	Stop Ring	1	048020-3-42		P-25	Level	1		
P-13	Screw	1	140270-0-01						

All other parts except above-mentioned parts are the same as those for 061-.

**Q.067** -  Needle Width 2mm  
(Thin, medium)

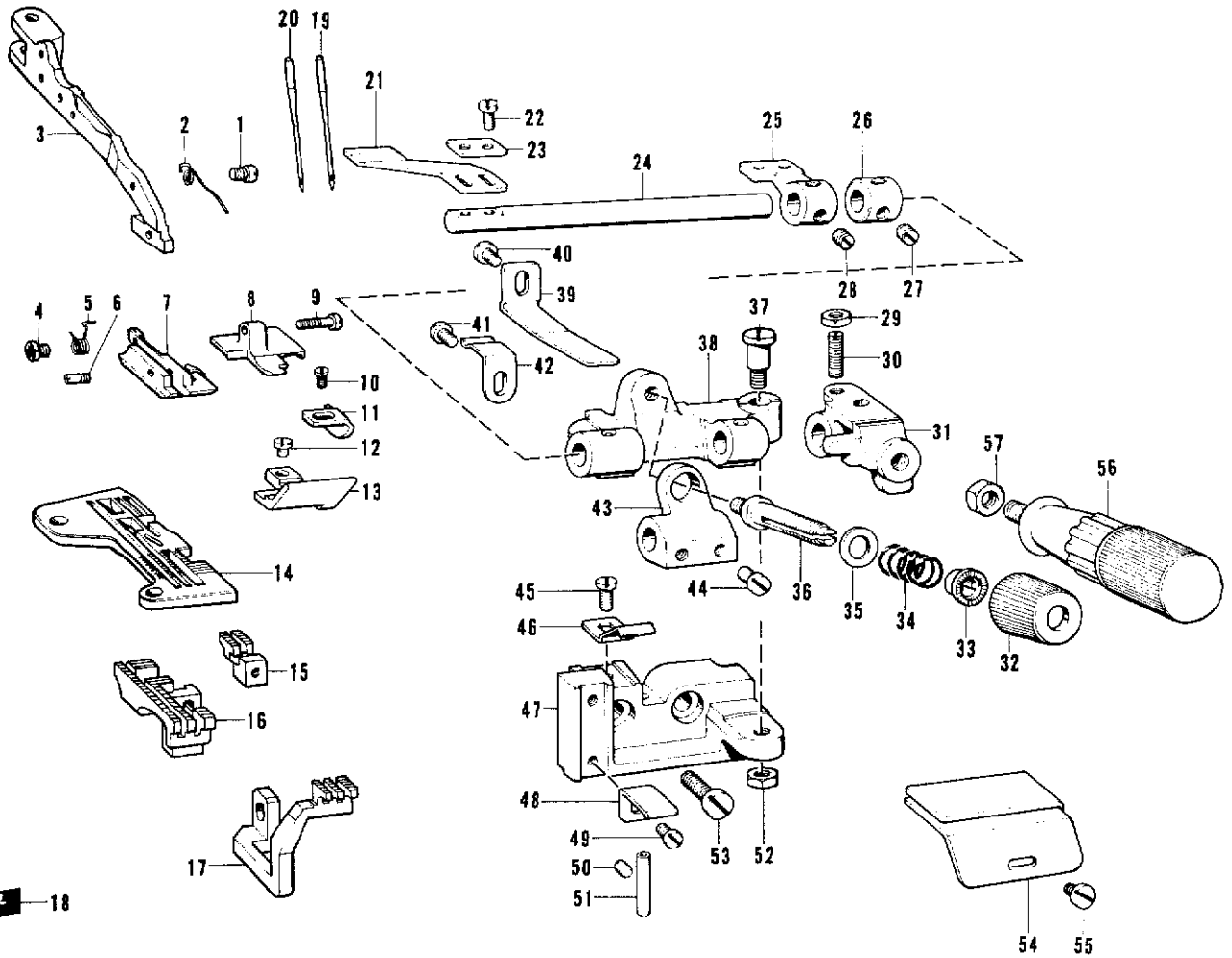

**067** - 18

Ref. No.	Name of Parts	Q'ty	Parts No.	Assembly No.	Ref. No.	Name of Parts	Q'ty	Parts No.	Assembly No.	
Q-1	Set Screw	1	140992-0-01	148158-0-01	Q-30	Screw	1	110230-0-01	146587-0-01	
Q-2	Spring	1	140993-0-01		Q-31	Handle Fixing Plate	1			
Q-3	Presser Arm	1			Q-32	Thread Tension Adjusting Nut	1	144106-0-02		
Q-4	Nut	1	140273-0-01		Q-33	Washer	1	144105-0-00		
Q-5	Spring	1	140275-0-01		Q-34	Spring	1	144788-0-01		
Q-6	Screw	1	140270-0-01		Q-35	Washer	1	025770-2-32		
Q-7	Presser Foot	1	146879-0-01		Q-36	Looper Thread Tension Control Stud	1	110820-0-01		
Q-8	Presser Foot (Rear)	1			Q-37	Screw	1	147933-0-01		
Q-9	Screw	1	140272-0-01		Q-38	Bracket for Ruffling Blade	1			
Q-10	Screw	1	105288-0-01		Q-39	Spring	1	145811-0-01		
Q-11	Presser Foot	1	144778-0-01		Q-40	Screw	1	009680-6-12		
Q-12	Screw	1	009660-7-12		Q-41	Screw	1	001670-5-12		146587-0-01
Q-13	Presser Foot (U)	1			Q-42	Spring	1	144764-0-01		
Q-14	Needle Plate	1		Q-43	Spring Base	1				
Q-15	Chain Feed Dog	1	148189-0-01	Q-44	Screw	2	105163-0-01			
Q-16	Main Feed Dog	1	148190-0-01	Q-45	Screw	1	009680-6-12			
Q-17	Differential Feed Dog	1	146575-0-01	Q-46	Spring	1	145808-0-01			
Q-18	Lavel	1		Q-47	Ruffler Base	1				
Q-19	Needle DC×1	1	112297-0-14	Q-48	Ruffling Blade Guide	2	145807-0-01			
Q-20	Needle DM×13	1	140104-0-14	Q-49	Screw	2	009680-8-12			
Q-21	Ruffling Blade	1	144783-0-01	Q-50	Screw	1	013679-4-12			
Q-22	Screw	2	009660-7-12	Q-51	Thread Guide Pipe	1	146592-0-01			
Q-23	Washer	1	144784-0-01	Q-52	Nut	1	021760-3-03			
Q-24	Ruffling Blade Base Shaft	1	145803-0-01	Q-53	Screw	2	009781-8-12			
Q-25	Lapper Base	1		Q-54	Ruffler Guide	1	144793-0-00			
Q-26	Set Collar	1		Q-55	Screw	1	112751-0-02			
Q-27	Screw	2	101706-0-01	Q-56	Handle	1	145809-0-01			
Q-28	Screw	2	101706-0-01	Q-57	Nut	1	021780-3-03			
Q-29	Nut	1	105234-0-03							

All other parts except above-mentioned parts are the same as those for 061-18.



R.069—○ Needle Width 3mm  
(Thin, medium)

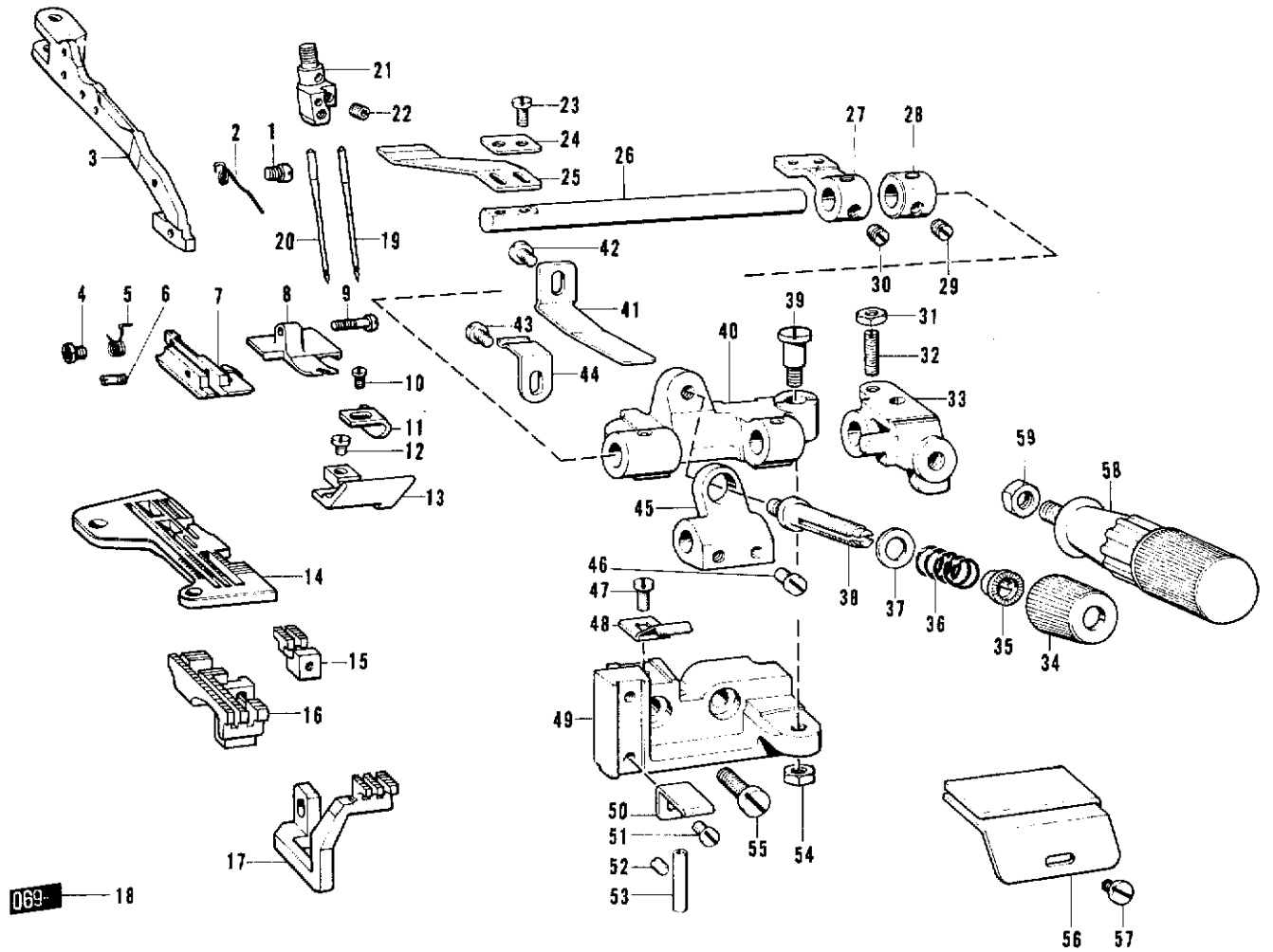

Ref. No.	Name of Parts	Q'ty	Parts No.	Assembly No.	Ref. No.	Name of Parts	Q'ty	Parts No.	Assembly No.
R-1	Set Screw	1	140992-0-01	148160-0-01	R-31	Nut	1	105234-0-03	146587-0-01
R-2	Spring	1	140993-0-01		R-32	Screw	1	110230-0-01	
R-3	Presser Arm	1			R-33	Handle Fixing Plate	1		
R-4	Screw	1	140273-0-01		R-34	Thread Tension Adjusting Nut	1	144106-0-02	
R-5	Spring	1	140275-0-01		R-35	Washer	1	144105-0-00	
R-6	Screw	1	140270-0-01		R-36	Spring	1	144788-0-01	
R-7	Presser Foot (E)	1			R-37	Washer	1	025770-2-32	
R-8	Presser Foot (Rear)	1			R-38	Looper Thread Tension Control Stud	1	110820-0-01	
R-9	Screw	1	140272-0-01		R-39	Screw	1	147933-0-01	
R-10	Screw	1	103288-0-01		R-40	Bracket for Ruffling Blade	1		
R-11	Presser Foot	1	144778-0-01		R-41	Spring	1	145811-0-01	
R-12	Screw	1	009660-7-12		R-42	Screw	1	009680-6-12	
R-13	Presser Foot (L)	1			R-43	Screw	1	001670-5-12	
R-14	Needle Plate	1			R-44	Spring	1	144764-0-01	
R-15	Chain Feed Dog (D)	1	148189-0-01		R-45	Spring Base	1		
R-16	Main Feed Dog	1	148190-0-01		R-46	Screw	2	105163-0-01	
R-17	Differential Feed Dog	1	146575-0-01		R-47	Screw	1	009680-6-12	
R-18	Level	1			R-48	Ruffling Blade Base Spring	1	145808-0-01	
R-19	Needle DC×1	1	112297-0-14		R-49	Ruffler Base	1		
R-20	Needle DM×13	1	140104-0-14	R-50	Ruffling Blade Guide	2	145807-0-01		
R-21	Needle Clamp	1		R-51	Screw	2	009680-8-12		
R-22	Screw	2	146427-0-01	R-52	Screw	1	013679-4-12		
R-23	Screw	2	009660-7-12	R-53	Thread Guide Pipe	1	146592-0-01		
R-24	Washer	1	144784-0-01	R-54	Nut	1	021760-3-03		
R-25	Ruffling Blade	1	144783-0-01	R-55	Screw	2	009781-8-12		
R-26	Ruffling Blade Base Shaft	1	145803-0-01	R-56	Ruffler Guide	1	144793-0-00		
R-27	Lapper Base	1		R-57	Screw	1	112751-0-02		
R-28	Set Collar	1		R-58	Handle	1	145809-0-01		
R-29	Screw	2	101706-0-01	R-59	Nut	1	021780-3-03		
R-30	Screw	2	101706-0-01						

All other parts except above-mentioned parts are the same as those for 061-...

S.071 -  Needle Width 5mm  
(Medium, heavy)

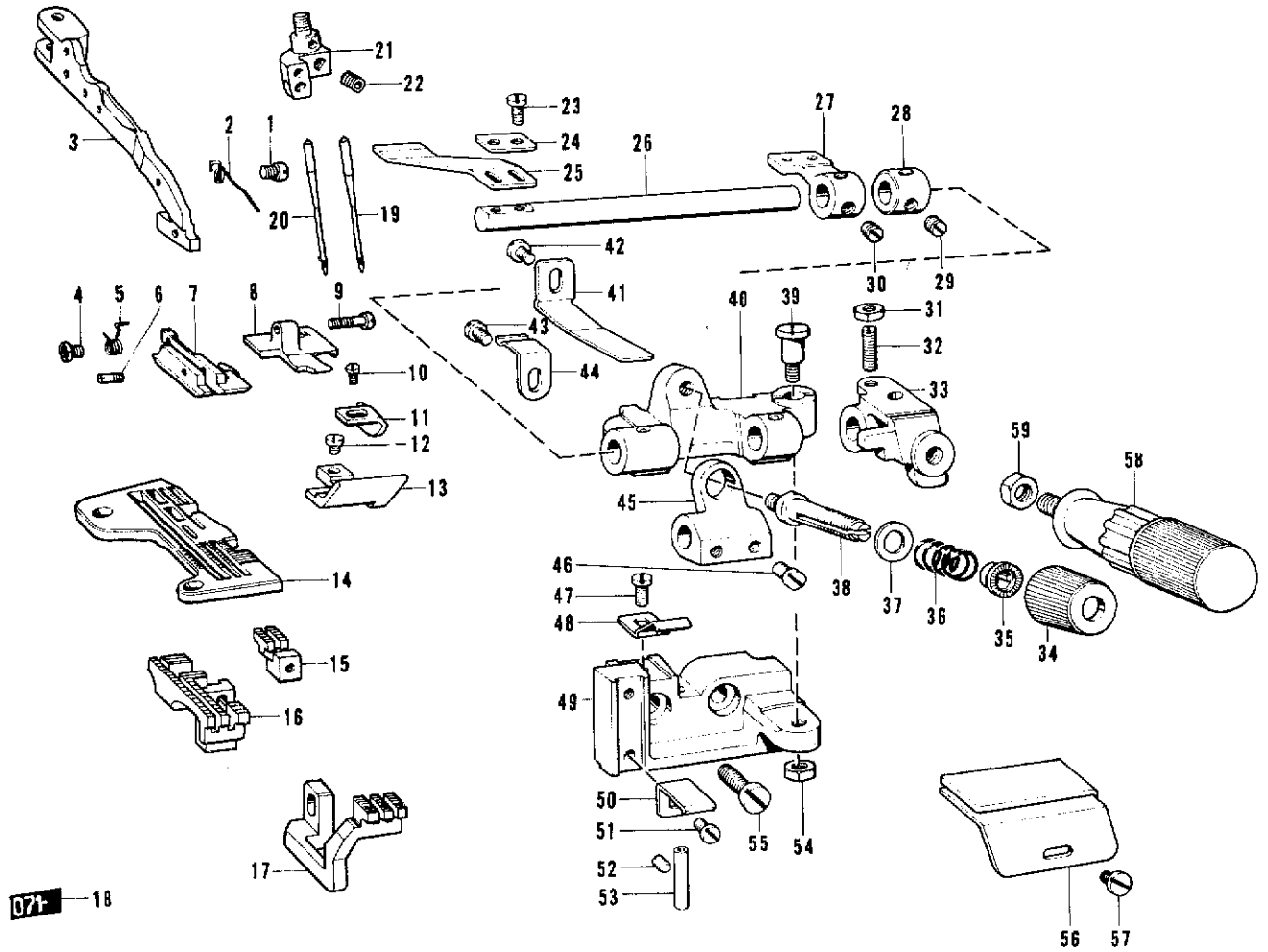

Ref. No.	Name of Parts	Q'ty	Parts No.	Assembly No.	Ref. No.	Name of Parts	Q'ty	Parts No.	Assembly No.
S-1	Set Screw	1	140992-0-01	148161-0-01	S-31	Nut	1	105234-0-03	146587-0-01
S-2	Spring	1	140993-0-01		S-32	Screw	1	110230-0-01	
S-3	Presser Arm	1			S-33	Handle Fixing Plate	1		
S-4	Screw	1	140273-0-01		S-34	Thread Tension Adjusting Nut	1	144106-0-02	
S-5	Spring	1	140275-0-01		S-35	Washer	1	144105-0-00	
S-6	Screw	1	140270-0-01		S-36	Spring	1	144788-0-01	
S-7	Presser Foot (D5)	1			S-37	Washer	1	025770-2-32	
S-8	Presser Foot (Rear)	1			S-38	Looper Thread Tension Control Stud	1	110820-0-01	
S-9	Screw	1	140272-0-01		S-39	Screw	1	147933-0-01	
S-10	Screw	1	105288-0-01		S-40	Bracket for Ruffling Blade	1		
S-11	Presser Foot	1	144778-0-01	S-41	Spring	1	145811-0-01		
S-12	Screw	1	009660-7-12	S-42	Screw	1	009680-6-12		
S-13	Presser Foot (U)	1		S-43	Screw	1	001670-5-12		
S-14	Needle Plate	1		S-44	Spring	1	144764-0-01		
S-15	Chain Feed Dog (D)	1	148189-0-01	S-45	Spring Base	1			
S-16	Main Feed Dog	1	148191-0-01	S-46	Screw	2	105163-0-01		
S-17	Differential Feed Dog	1	146576-0-01	S-47	Screw	1	009680-6-12		
S-18	Lavel	1		S-48	Ruffling Blade Base Spring	1	145808-0-01		
S-19	Needle DC × 1	1	112297-0-14	S-49	Ruffler Base	1			
S-20	Needle DM × 13	1	140104-0-14	S-50	Ruffling Blade Guide	2	145807-0-01		
S-21	Needle Clamp	1		S-51	Screw	2	009680-8-12		
S-22	Screw	2	146427-0-01	S-52	Screw	1	013679-4-12		
S-23	Screw	2	009660-7-12	S-53	Thread Guide Pipe	1	146592-0-01		
S-24	Washer	1	144784-0-01	S-54	Nut	1	021760-3-03		
S-25	Ruffling Blade	1	144783-0-01	S-55	Screw	2	009781-8-12		
S-26	Ruffling Blade Base Shaft	1	145803-0-01	S-56	Ruffler Guide	1	144793-0-00		
S-27	Lapper Base	1		S-57	Screw	1	112751-0-02		
S-28	Set Collar	1		S-58	Handle	1	145809-0-01		
S-29	Screw	2	101706-0-01	S-59	Nut	1	021780-3-03		
S-30	Screw	2	101706-0-01						

All other parts except above-mentioned parts are the same as those for 061-

T.073—○ Needle Width 2mm.  
(Thin, medium Ruffling (W/Piping))

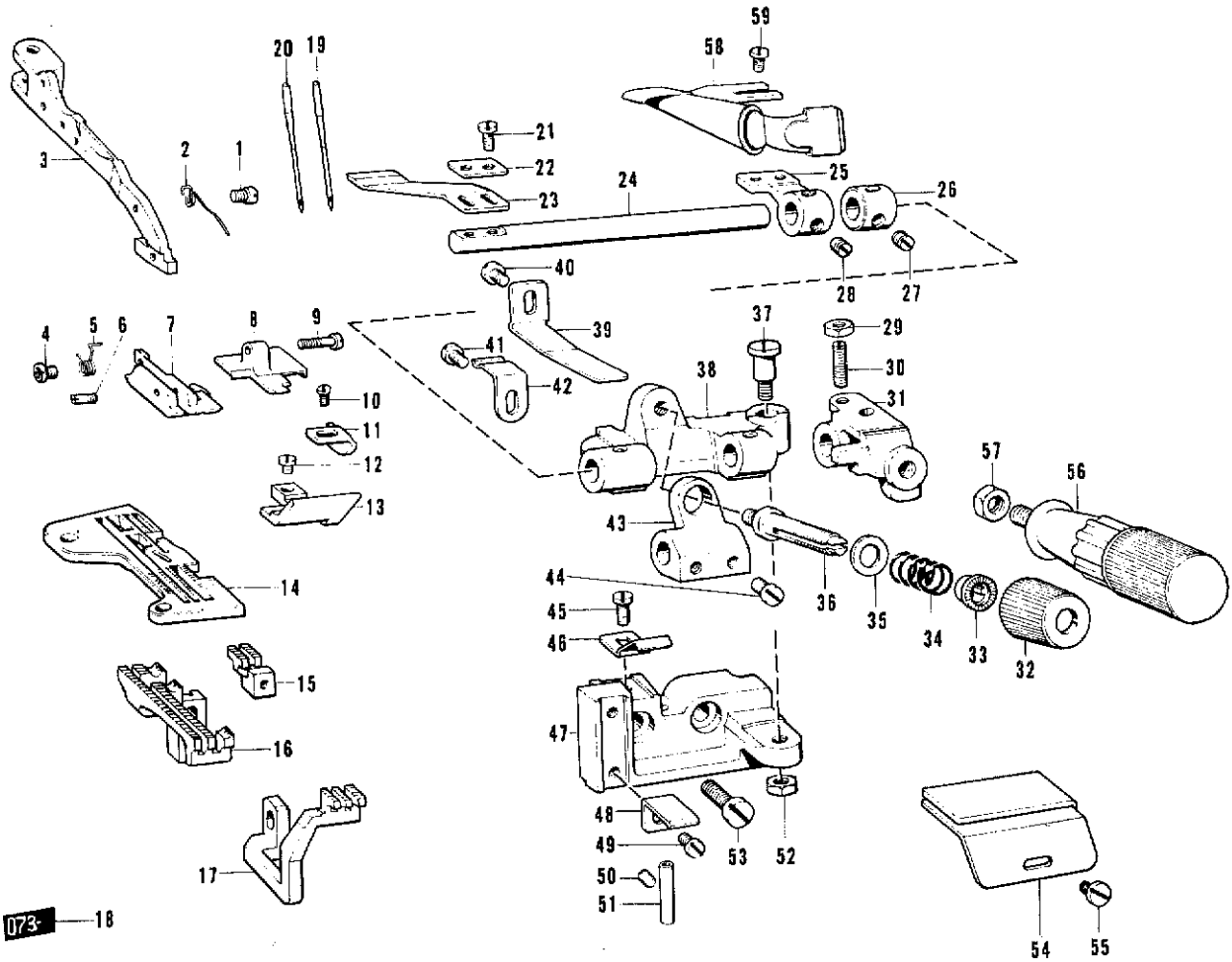

Ref. No.	Name of Parts	Q'ty	Parts No.	Assembly No.	Ref. No.	Name of Parts	Q'ty	Parts No.	Assembly No.
T-1	Set Screw	1	140992-0-01	148747-0-01	T-31	Handle Fixing Plate	1		146587-0-01
T-2	Spring	1	140993-0-01		T-32	Thread Tension Adjusting Nut	1	144106-0-02	
T-3	Presser Arm	1			T-33	Washer	1	144105-0-00	
T-4	Screw	1	140273-0-01		T-34	Spring	1	144788-0-01	
T-5	Spring	1	140275-0-01		T-35	Washer	1	025770-2-32	
T-6	Screw	1	140270-0-01		T-36	Looper Thread Tension Control Stud	1	110820-0-01	
T-7	Presser Foot	1			T-37	Screw	1	147933-0-01	
T-8	Presser Foot (Rear)	1			T-38	Bracket for Ruffling Blade	1		
T-9	Screw	1	140272-0-01		T-39	Spring	1	145811-0-01	
T-10	Screw	1	105288-0-01		T-40	Screw	1	009680-6-12	
T-11	Presser Foot	1	144778-0-01		T-41	Screw	1	001670-5-12	
T-12	Screw	1	009660-7-12		T-42	Spring	1	144764-0-01	
T-13	Presser Foot (U)	1			T-43	Spring Base	1		
T-14	Needle Plate	1			T-44	Screw	2	105163-0-01	
T-15	Chain Feed Dog (D)	1	148189-0-01	T-45	Screw	1	009680-6-12		
T-16	Main Feed Dog	1	148750-0-01	T-46	Ruffling Blade Base Spring	1	145808-0-01		
T-17	Differential Feed Dog	1	146575-0-01	T-47	Ruffler Base	1			
T-18	Lavel	1		T-48	Ruffling Blade Guide	2	145807-0-01		
T-19	Needle DC×1	1	112297-0-14	T-49	Screw	2	009680-8-12		
T-20	Needle DM×13	1	140104-0-14	T-50	Screw	1	013679-4-12		
T-21	Screw	2	009660-7-12	T-51	Thread Guide Pipe	1	146592-0-01		
T-22	Washer	1	144784-0-01	T-52	Nut	1	021760-3-03		
T-23	Ruffling Blade	1	144783-0-01	T-53	Screw	2	009781-8-12		
T-24	Ruffling Blade Base Shaft	1	145803-0-01	T-54	Ruffler Guide	1	144793-0-00		
T-25	Lapper Base	1		T-55	Screw	1	112751-0-02		
T-26	Set Collar	1		T-56	Handle	1	145809-0-01		
T-27	Screw	2	101706-0-01	T-57	Nut	1	021780-3-03		
T-28	Screw	2	101706-0-01	T-58	Lapper	1	147440-0-00		
T-29	Nut	1	105234-0-03	T-59	Screw	1	009680-6-12		
T-30	Screw	1	110230-0-01						

All other parts except above-mentioned parts are the same as those for 061-...

U.075-○ Needle Width 3mm  
(Thin, medium Ruffling (W/Piping))

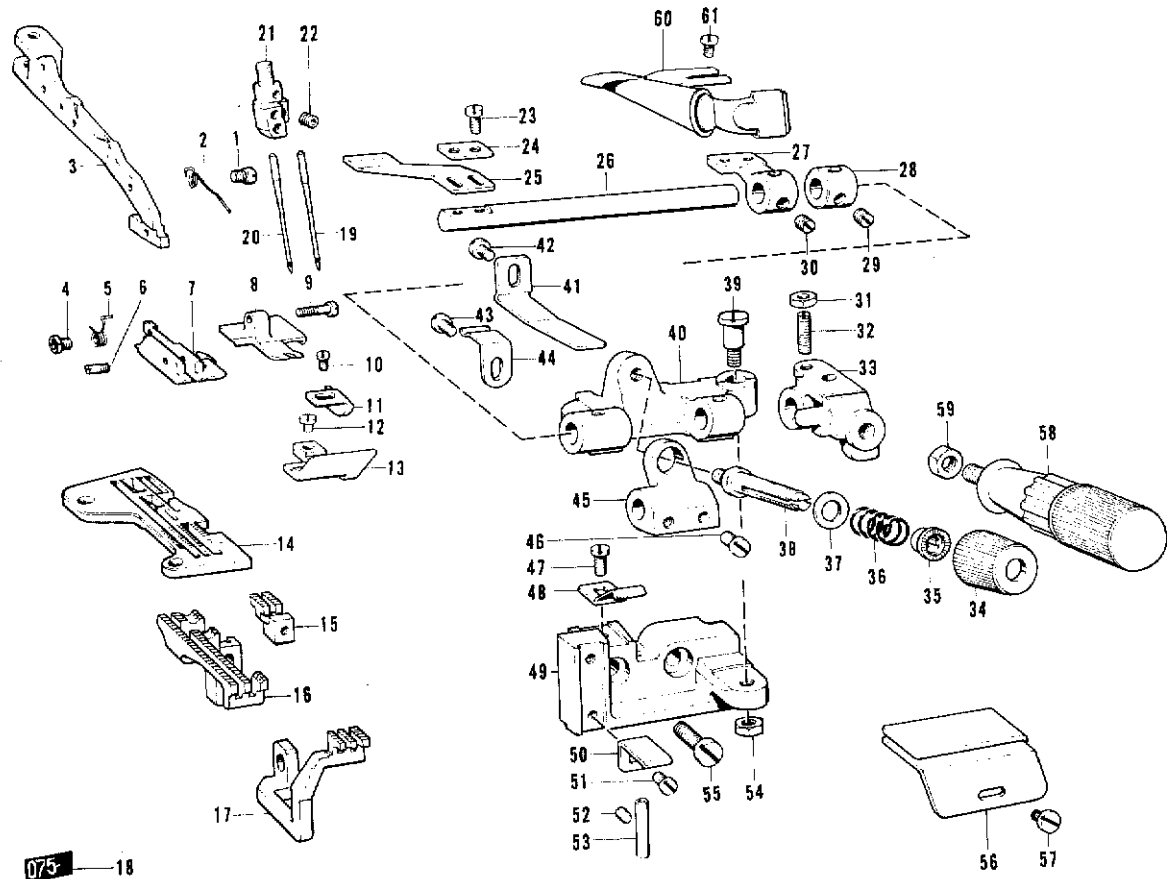

Ref. No.	Name of Parts	Q'ty	Parts No.	Assembly No.	Ref. No.	Name of Parts	Q'ty	Parts No.	Assembly No.
U-1	Set Screw	1	140992-0-01	148748-0-01	U-32	Screw	1	110230-0-01	146587-0-01
U-2	Spring	1	140993-0-01		U-33	Handle Fixing Plate	1		
U-3	Presser Arm	1			U-34	Thread Tension Adjusting Nut	1	144106-0-02	
U-4	Screw	1	140273-0-01		U-35	Washer	1	144105-0-00	
U-5	Spring	1	140275-0-01		U-36	Spring	1	144788-0-01	
U-6	Screw	1	140270-0-01		U-37	Washer	1	025770-2-32	
U-7	Presser Foot	1			U-38	Looper Thread Tension Control Stud	1	110820-0-01	
U-8	Presser Foot (Rear)	1			U-39	Screw	1	147933-0-01	
U-9	Screw	1	140272-0-01		U-40	Bracket for Ruffling Blade	1		
U-10	Screw	1	105288-0-01		U-41	Spring	1	145811-0-01	
U-11	Presser Foot	1	144778-0-01		U-42	Screw	1	009680-6-12	
U-12	Screw	1	009660-7-12		U-43	Screw	1	001670-5-12	
U-13	Presser Foot (U)	1			U-44	Spring	1	144764-0-01	
U-14	Needle Plate	1		U-45	Spring Base	1			
U-15	Chain Feed Dog (D)	1	148189-0-01	U-46	Screw	2	105163-0-01		
U-16	Main Feed Dog	1	148751-0-01	U-47	Screw	1	009680-6-12		
U-17	Differential Feed Dog	1	146575-0-01	U-48	Ruffling Blade Base Spring	1	145808-0-01		
U-18	Lavel	1		U-49	Ruffler Base	1			
U-19	Needle DC×1	1	112297-0-14	U-50	Ruffling Blade Guide	2	145807-0-01		
U-20	Needle DM×13	1	140104-0-14	U-51	Screw	2	009680-8-12		
U-21	Needle Clamp 3	1		U-52	Screw	1	013679-4-12		
U-22	Screw	2	146427-0-01	U-53	Thread Guide Pipe	1	146592-0-01		
U-23	Screw	2	009660-7-12	U-54	Nut	1	021760-3-03		
U-24	Washer	1	144784-0-01	U-55	Screw	2	009781-8-12		
U-25	Ruffling Blade	1	144783-0-01	U-56	Ruffler Guide	1	144793-0-00		
U-26	Ruffling Blade Base Shaft	1	145803-0-01	U-57	Screw	1	112751-0-02		
U-27	Lapper Base	1		U-58	Handle	1	145809-0-01		
U-28	Set Collar	1		U-59	Nut	1	021780-3-03		
U-29	Screw	2	101706-0-01	U-60	Lapper	1	147440-0-00		
U-30	Screw	2	101706-0-01	U-61	Screw	1	009680-6-12		
U-31	Nut	1	105234-0-03						

All other parts except above-mentioned parts are the same as those for 061-○.

V.077-○ Needle Width 5mm  
(Thin, medium Ruffling (W/Piping))

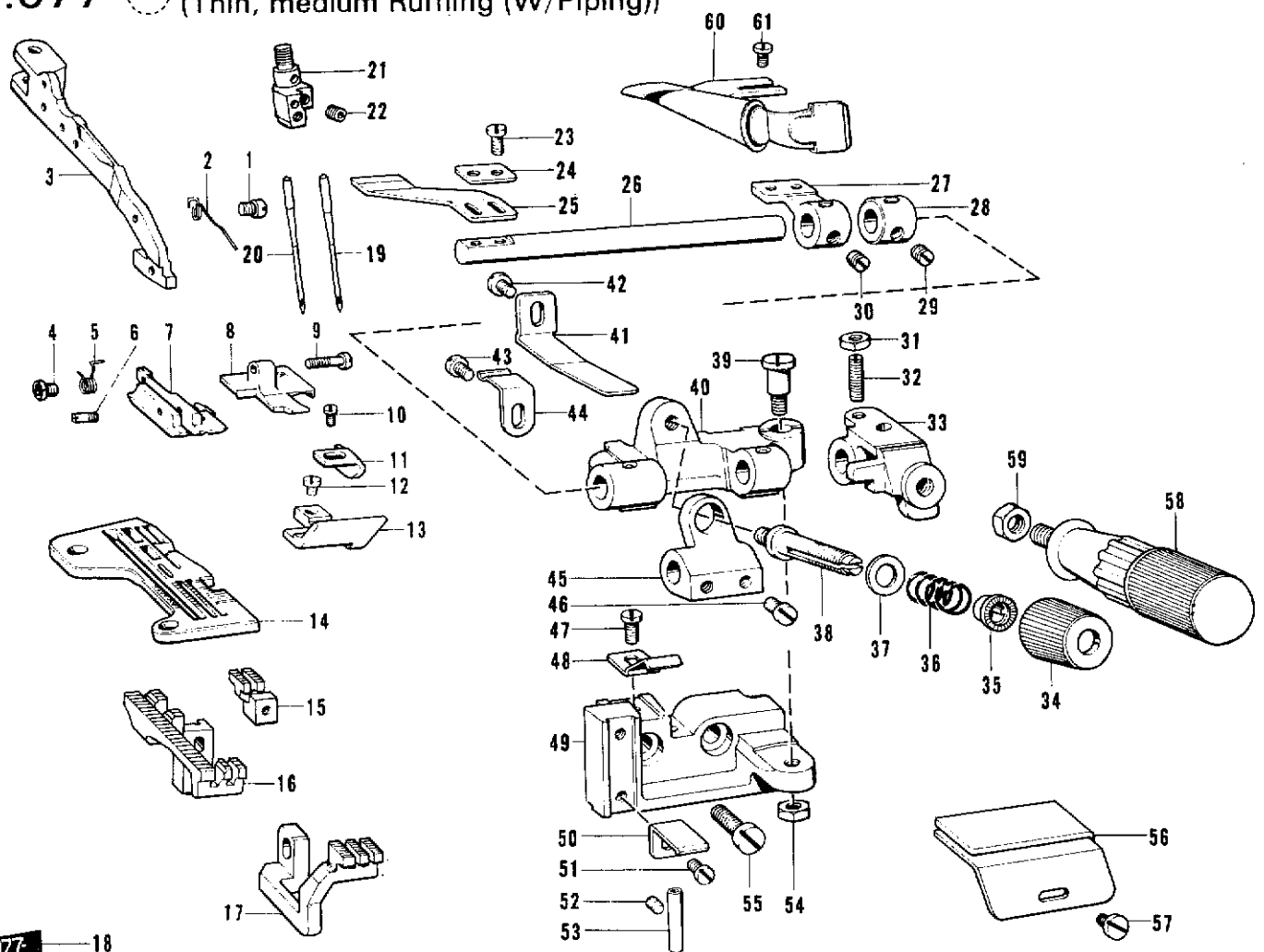

077-18

Ref. No.	Name of Parts	Q'ty	Parts No.	Assembly No.	Ref. No.	Name of Parts	Q'ty	Parts No.	Assembly No.
V-1	Set Screw	1	140992-0-01	148749-0-01	V-32	Screw	1	110230-0-01	146587-0-01
V-2	Spring	1	140993-0-01		V-33	Handle Fixing Plate	1		
V-3	Presser Arm	1			V-34	Thread Tension Adjusting	1	144106-0-02	
V-4	Screw	1	140273-0-01		V-35	Washer	1	144105-0-00	
V-5	Spring	1	140275-0-01		V-36	Spring	1	144788-0-01	
V-6	Screw	1	140270-0-01		V-37	Washer	1	025770-2-32	
V-7	Presser Foot	1			V-38	Looper Thread Tension Control Stud	1	110820-0-01	
V-8	Presser Foot (Rear)	1			V-39	Screw	1	147933-0-01	
V-9	Screw	1	140272-0-01		V-40	Bracket for Ruffling Blade	1		
V-10	Screw	1	105288-0-01		V-41	Spring	1	145811-0-01	
V-11	Presser Foot	1	144778-0-01		V-42	Screw	1	009680-6-12	
V-12	Screw	1	009660-7-12		V-43	Screw	1	001670-5-12	
V-13	Presser Foot (U)	1			V-44	Spring	1	144764-0-01	
V-14	Needle Plate	1		V-45	Spring Base	1			
V-15	Chain Feed Dog (D)	1	148189-0-01	V-46	Screw	2	105163-0-01		
V-16	Main Feed Dog	1	148752-0-01	V-47	Screw	1	009680-6-12		
V-17	Differential Feed Dog	1	146575-0-01	V-48	Ruffling Blade Base Spring	1	145808-0-01		
V-18	Lavel	1		V-49	Ruffler Base	1			
V-19	Needle DC×1	1	112297-0-14	V-50	Ruffling Blade Guide	2	145807-0-01		
V-20	Needle DM×13	1	140104-0-14	V-51	Screw	2	009680-8-12		
V-21	Needle Clamp 3	1		V-52	Screw	1	013679-4-12		
V-22	Screw	2	146427-0-01	V-53	Thread Guide Pipe	1	146592-0-01		
V-23	Screw	2	009660-7-12	V-54	Nut	1	021760-3-03		
V-24	Washer	1	144784-0-01	V-55	Screw	2	009781-8-12		
V-25	Ruffling Blade	1	144783-0-01	V-56	Ruffler Guide	1	144793-0-00		
V-26	Ruffling Blade Base Shaft	1	145803-0-01	V-57	Screw	1	112751-0-02		
V-27	Lapper Base	1		V-58	Handle	1	145809-0-01		
V-28	Set Collar	1		V-59	Nut	1	021780-3-03		
V-29	Screw	2	101706-0-01	V-60	Lapper	1	147440-0-00		
V-30	Screw	2	101706-0-01	V-61	Screw	1	009680-6-12		
V-31	Nut	1	105234-0-03						

All other parts except above-mentioned parts are the same as those for 061-○.

W.081 -  Needle Width 3mm  
(Thin, medium taping)

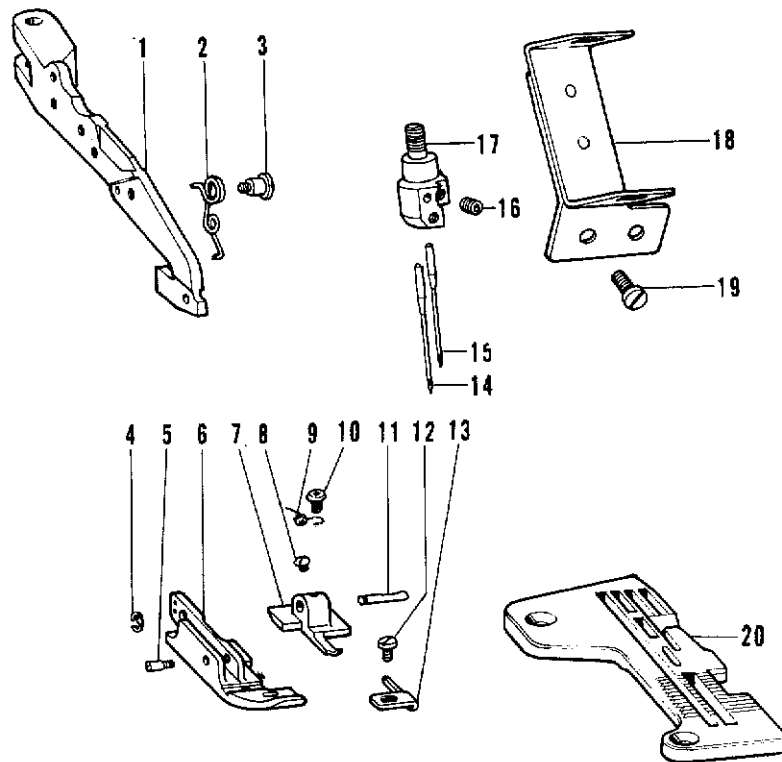

081-21

Ref. No.	Name of Parts	Q'ty	Parts No.	Assembly No.	Ref. No.	Name of Parts	Q'ty	Parts No.	Assembly No.
W- 1	Presser Arm	1		148162-0-01	W-12	Screw	1	105288-0-01	148162-0-01
W- 2	Spring	1	148152-0-01		W-13	Presser Foot (Front)	1	145147-0-01	
W- 3	Stud Screw	1	146901-0-01		W-14	Needle DM×13	1	140104-0-14	
W- 4	Stop Ring	1	048020-3-42		W-15	Needle DC×1	1	112297-0-14	
W- 5	Screw	1	146865-0-01		W-16	Screw	2	146427-0-01	146489-0-01
W- 6	Presser Foot	1			W-17	Needle Clamp 3	1		
W- 7	Presser Foot (Rear)	1			W-18	Tape Guide	1	146883-0-01	
W- 8	Screw	1	105288-0-01		W-19	Screw	2	009669-4-12	
W- 9	Spring	1	146870-0-01		W-20	Needle Plate	1		
W-10	Screw	1	122771-0-02		W-21	Level	1		
W-11	Pin	1	146868-0-01						

All other parts except above-mentioned parts are the same as those for 061 .

W:087- Needle Width 5mm  
(Extra heavy)

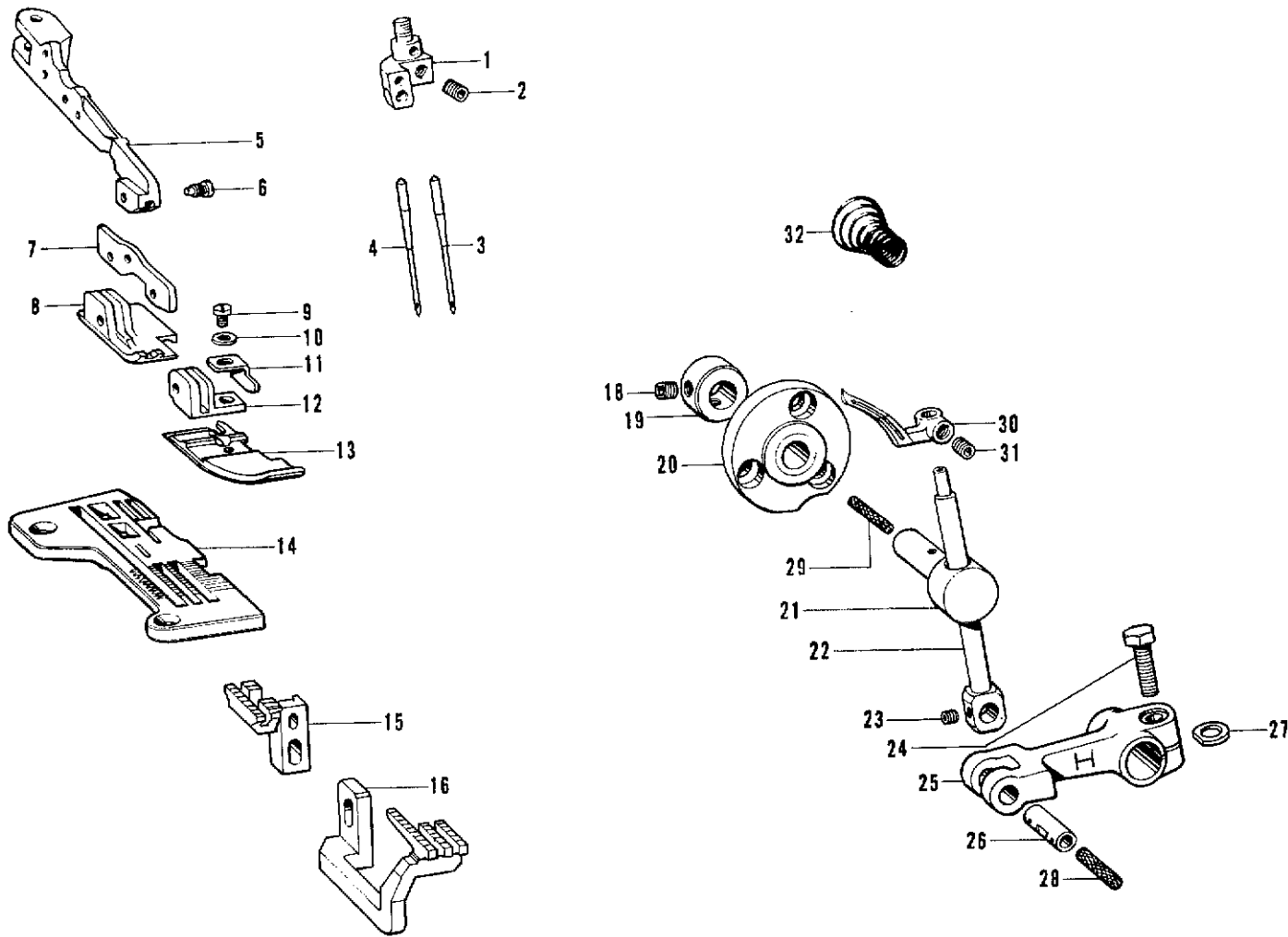

087-17

Ref. No.	Name of Parts	Q'ty	Parts No.	Assembly No.	Ref. No.	Name of Parts	Q'ty	Parts No.	Assembly No.
W:1	Needle Clamp 5	1		146491-0-01	W:17	Lavel	1		
W:2	Screw	1	146427-0-01		W:18	Screw	2	014680-4-22	
W:3	Needle DC×1	1	112297-0-21		W:19	Set Collar	1		
W:4	Needle DM×13	1	140104-0-21		W:20	Over Looper Holder Guide Base	1		
W:5	Presser Foot	1			W:21	Over Looper Holder Guide Block	1		
W:6	Screw	3	148015-0-01		W:22	Over Looper Holder	1		
W:7	Presser Foot Supporter	1	148016-0-01		W:23	Screw	1	146427-0-01	148217-0-01
W:8	Presser Foot (Rear)	1			W:24	Bolt	1	017761-6-12	
W:9	Screw	1	009660-0-12	148260-6-01	W:25	Over Looper Driving Lever	1		
W:10	Washer	1	025030-2-32		W:26	Over Looper Holder Pin	1		
W:11	Presser Foot (Front)	1	148020-0-01		W:27	Spacer	1	148783-0-01	
W:12	Presser Foot Supporter	1	148017-0-01		W:28	Wick	1	108809-0-01	
W:13	Presser Foot	1			W:29	Wick	1	148249-0-00	
W:14	Needle Plate	1			W:30	Over Looper	1		
W:15	Main Feed Dog	1	146569-0-01		W:31	Screw	1	014680-4-22	147973-0-01
W:16	Differential Feed Dog	1	146574-0-01		W:32	Spring	2	148851-0-01	

All other parts except above-mentioned parts are the same as those for 061-.

a. 089- Needle Width 3 mm  
(Thin, medium binding)

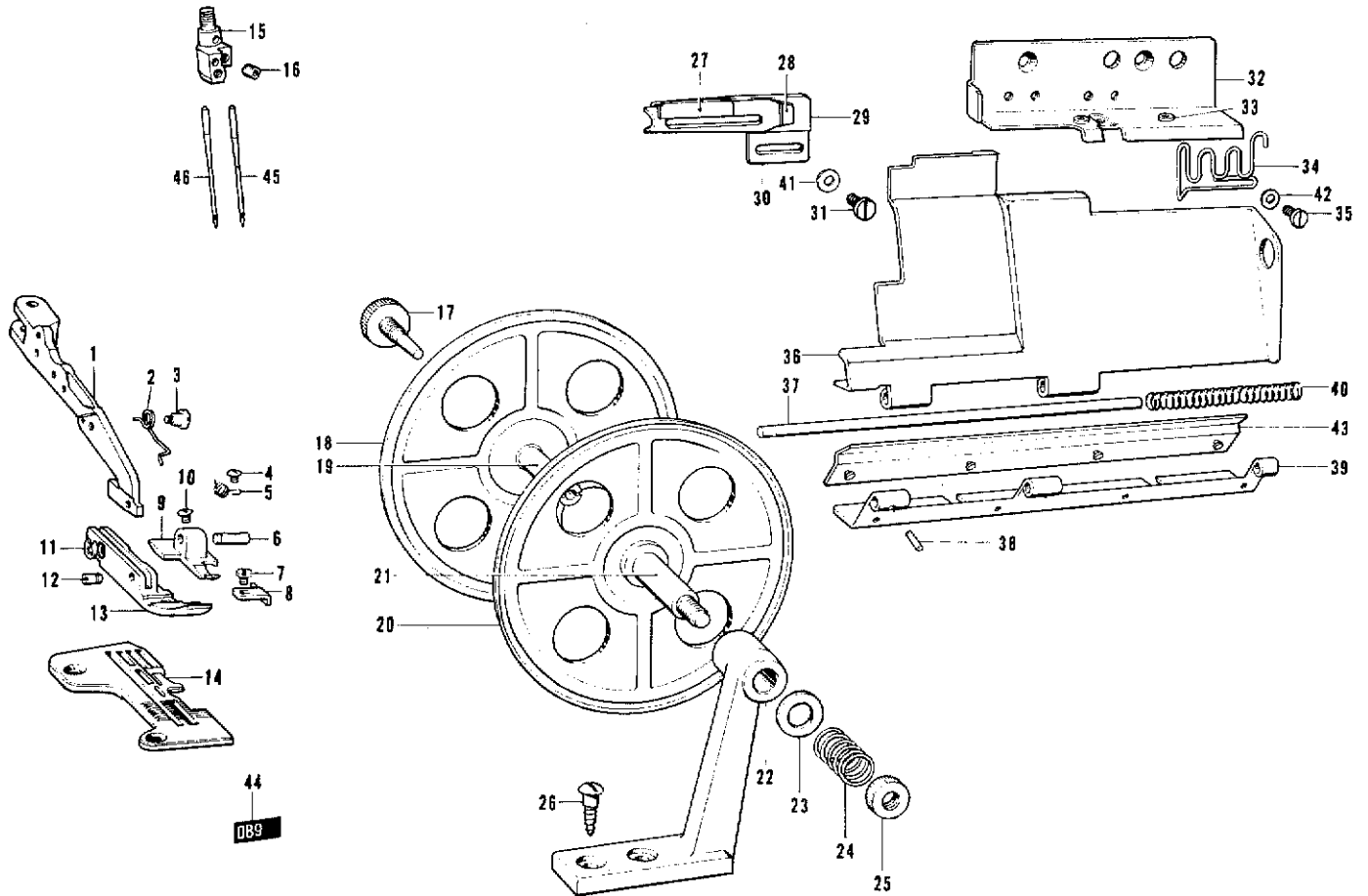

Ref. No.	Name of Parts	Q'ty	Parts No.	Assembly No.	Ref. No.	Name of Parts	Q'ty	Parts No.	Assembly No.
a-1	Presser Arm	1		148263-0-01	a-24	Spring	1	108495-0-01	143767-0-02
a-2	Spring	1	148152-0-01		a-25	Tension Control Nut	1	100136-0-01	
a-3	Stud Screw	1	146901-0-01		a-26	Screw	2	101118-0-01	
a-4	Screw	1	122771-0-02		a-27	Lapper F	1		147373-0-00
a-5	Spring	1	146870-0-01		a-28	Lapper B	1		
a-6	Pin	1	146868-0-01		a-29	Lapper Body	1		
a-7	Screw	1	105288-0-01		a-30	Cloth Cover Plate	1		
a-8	Presser Foot (Front)	1	147371-0-01		a-31	Screw	2	009670-5-12	147367-0-01
a-9	Presser Foot (Rear)	1			a-41	Washer	2	025350-3-32	
a-10	Screw	1	105288-0-01		a-32	Supporter for Front Cover	1		
a-11	Stop Ring	1	048020-3-42		a-33	Thread Bushing	2	146924-0-00	
a-12	Screw	1	146865-0-01		a-34	Tape Guide	1	147377-0-01	
a-13	Presser Foot	1			a-42	Washer	2	025350-3-32	
a-14	Needle Plate	1			a-35	Screw	2	009670-5-12	148989-0-01
a-15	Needle Clamp 3	1		a-36	Front Cover	1			
a-16	Screw	2	146427-0-01	a-37	Shaft for Front Cover	1	146441-0-00		
a-17	Screw	1	143980-0-01	a-38	Pin	1	047140-8-42		
a-18	Tape Winder Wheel (L)	1		a-39	Front Cover Hinge	1	146440-0-01		
a-19	Tape Winder Wheel Shaft (L)	1		a-40	Spring	1	146442-0-01		
a-20	Tape Winder Wheel (R)	1		a-43	Hinge Cover	1	148984-0-01		
a-21	Tape Winder Wheel Shaft (R)	1		a-44	Lavel	1			
a-22	Tape Winder Bracket	1	143750-0-02	a-45	Needle DC×1	1	112297-0-14		
a-23	Washer	1	108494-0-01	a-46	Needle DM×13	1	140104-0-14		

★All other parts except above-mentioned parts are the same as those for 061-



b.092- Needle Width 5mm  
(Extra heavy)

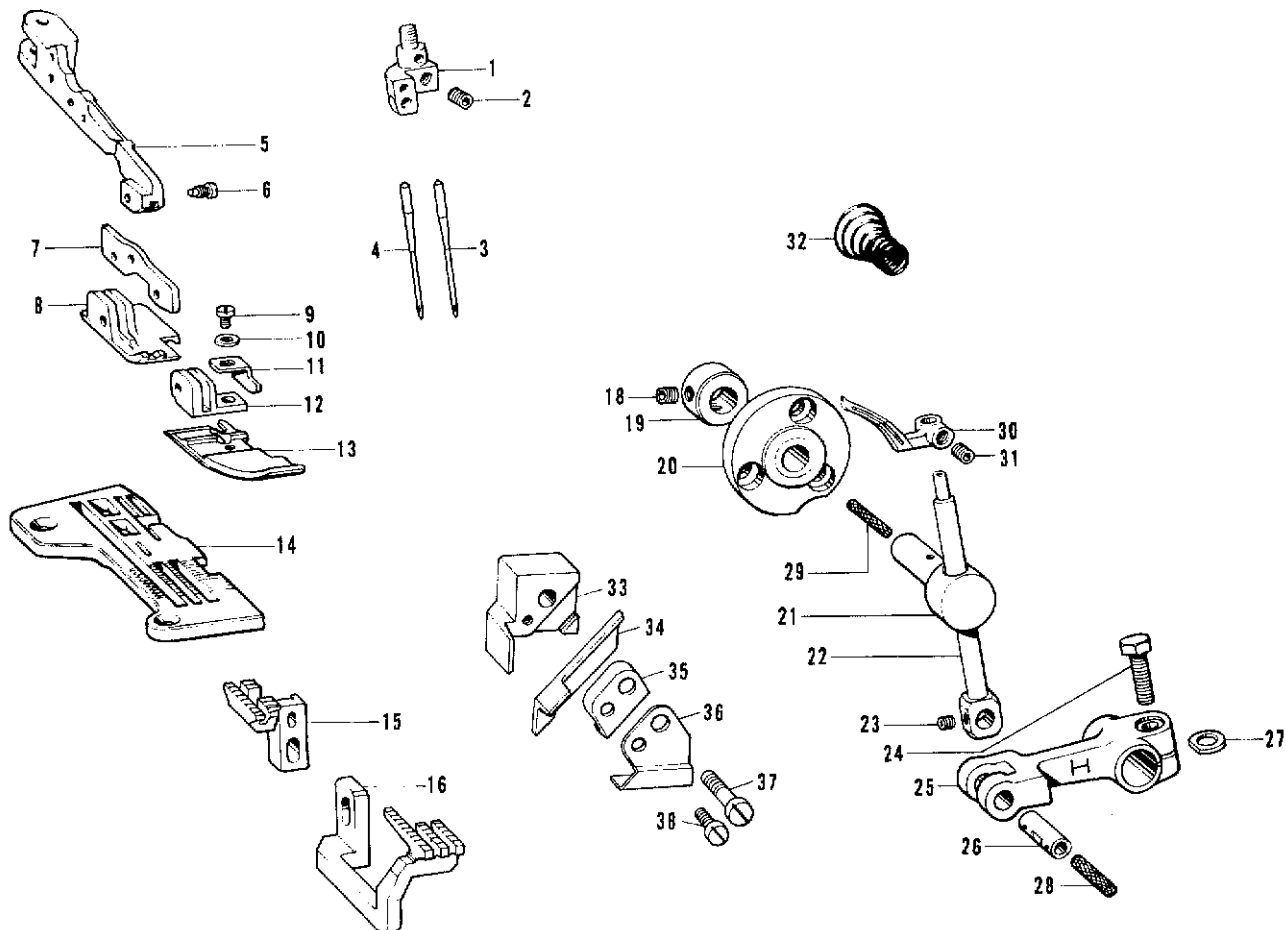

092-17

Ref. No.	Name of Parts	Q'ty	Parts No.	Assembly No.	Ref. No.	Name of Parts	Q'ty	Parts No.	Assembly No.
b-1	Needle Clamp 5	1		146491-0-01	b-20	Over Looper Holder Guide Base	1		148217-0-01
b-2	Screw	1	146427-0-01		b-21	Over Looper Holder Guide Block	1		
b-3	Needle DC×1	1	112297-0-21		b-22	Over Looper Holder	1		
b-4	Needle DM×13	1	140104-0-21		b-23	Screw	1	146427-0-01	
b-5	Presser Foot	1			b-24	Bolt	1	017761-6-12	
b-6	Screw	3	148015-0-01		b-25	Over Looper Driving Lever	1		
b-7	Presser Foot Supporter	1	148016-0-01		b-26	Over Looper Holder Pin	1		
b-8	Presser Foot (Rear)	1			b-27	Spacer	1	148783-0-01	
b-9	Screw	1	009660-6-12	148260-0-01	b-28	Wick	1	108809-0-01	
b-10	Washer	1	025030-2-32		b-29	Wick	1	148249-0-00	
b-11	Presser Foot (Front)	1	148020-0-01		b-30	Over Looper	1		147937-0-01
b-12	Presser Foot Supporter	1	148017-0-01		b-31	Screw	1	014680-4-22	
b-13	Presser Foot	1			b-32	Spring	2	148851-0-01	
b-14	Needle Plate	1			b-33	Upper Knife Holder	1	148345-0-01	
b-15	Main Feed Dog	1	146569-0-01		b-34	Upper Knife	1	148342-0-01	
b-16	Differential Feed Dog	1	146574-0-01		b-35	Upper Knife Presser	1	148343-0-01	
b-17	Level	1			b-36	Upper Knife Presser Plate	1	148344-0-01	
b-18	Screw	2	014680-4-22	148217-0-01	b-37	Screw	1	102424-0-03	
b-19	Set Collar	1			b-38	Screw	1	009671-0-14	

All other parts except above-mentioned parts are the same as those for 061-.

## X. Cord Guide

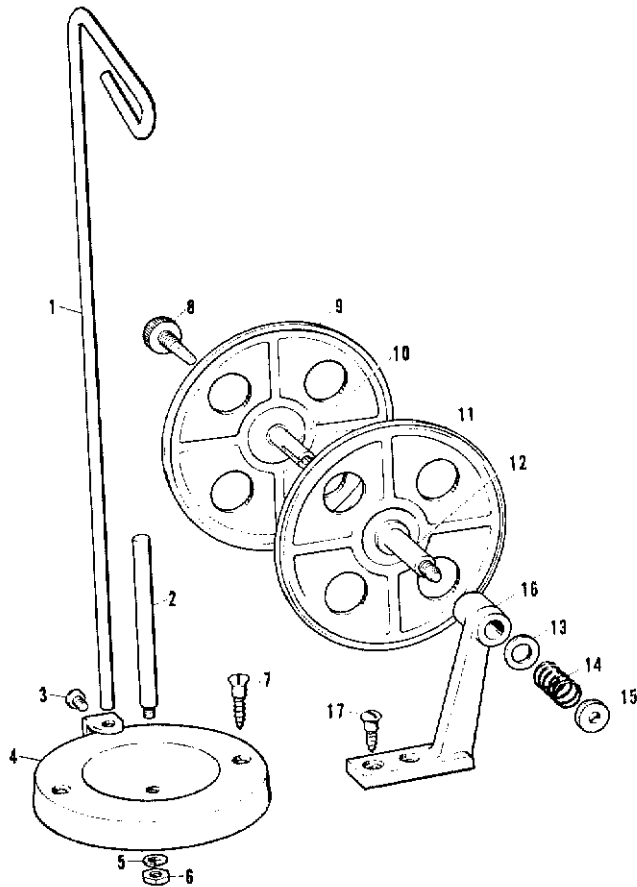

Ref. No.	Name of Parts	Q'ty	Parts No.	Assembly No.	
X- 1	Thread Guide Stud	1	109853-0-01	109854-0-01	
X- 2	Spool Stand	1	100444-0-02		
X- 3	Screw	1	100080-0-02		
X- 4	Disc for Spool	1	109852-0-01		
X- 5	Washer	1	028050-2-42		
X- 6	Nut	1	110161-0-03		
X- 7	Screw	2	100447-0-01		181031-0-01
X- 8	Screw	1	143980-0-01		
X- 9	Tape Winder Wheel (L)	1			143978-0-01
X-10	Tape Winder Wheel Shaft (L)	1			
X-11	Tape Winder Wheel (R)	1			143976-0-01
X-12	Tape Winder Wheel Shaft (R)	1			
X-13	Washer	1	108494-0-01		143767-0-02
X-14	Spring	1	108495-0-01		
X-15	Tension Control Nut	1	100136-0-01		
X-16	Tape Winder Bracket	1	143750-0-02		
X-17	Screw	2	101118-0-01		

## Z. Machine Head Plate and Spool Stand

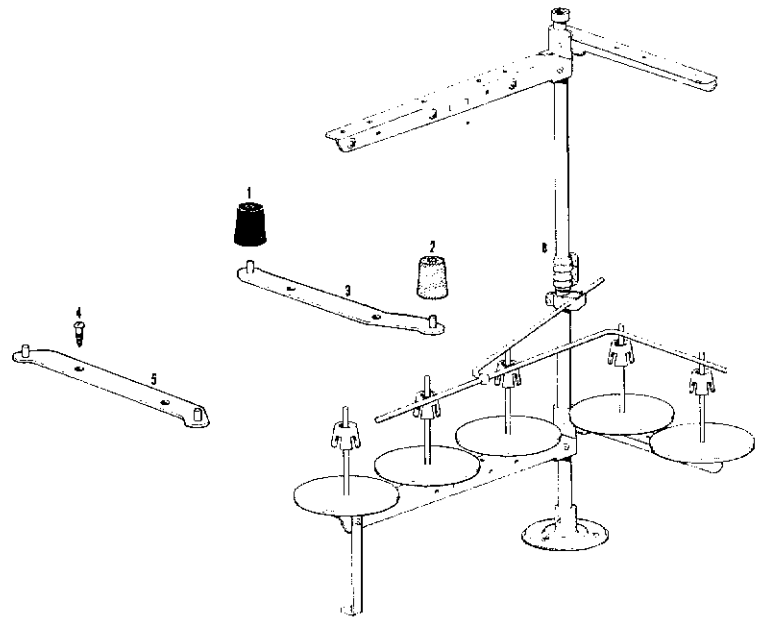

Ref. No.	Name of Parts	Q'ty	Parts No.	Assembly No.
Z-1	Rubber Cushion	1	147919-0-01	150162-0-01
Z-2	Rubber Cushion	3	147919-0-02	
Z-3	Cushion Base (Right)	1	148290-0-01	
Z-4	Screw	4	034151-6-03	
Z-5	Cushion Base (Left)	1	148292-0-01	
Z-8	Cotton Stand Assembly	1	150162-0-01	

## Z'. Accessories

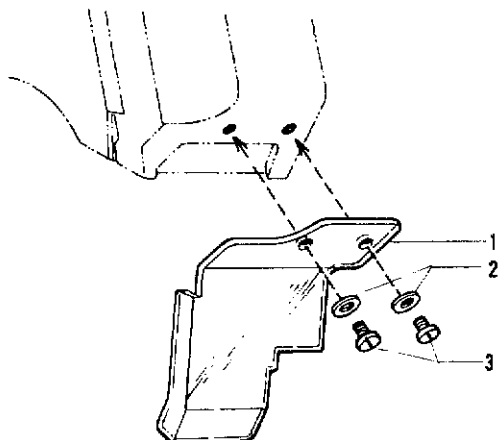

Ref. No.	Name of Parts	Q'ty	Parts No.	Assembly No.
Z'-1	Eye Guard	1		151017-0-01
Z'-2	Washer	2	025030-2-32	
Z'-3	Screw	2	009660-5-12	

# Y. Accessories

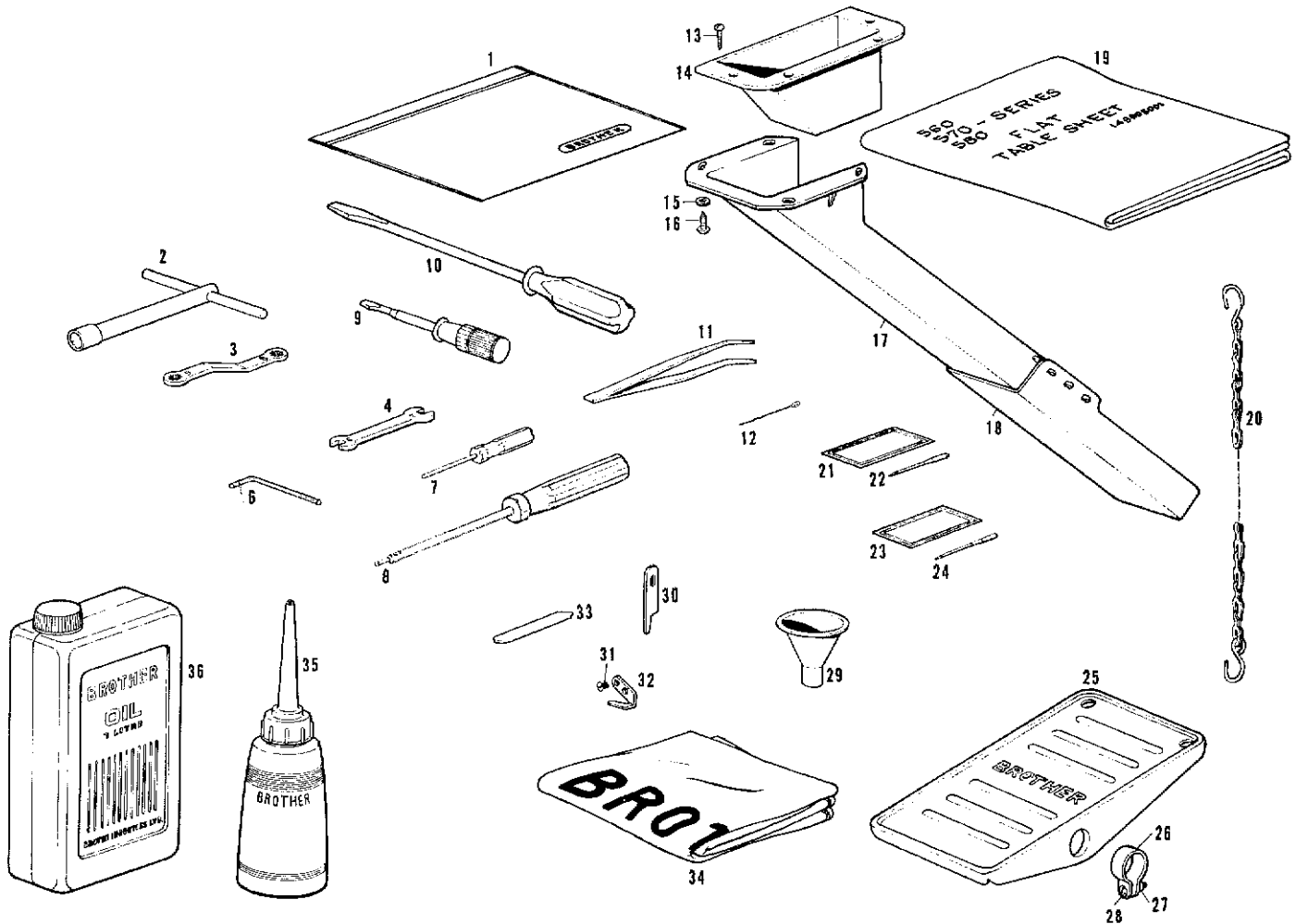

Ref. No.	Name of Parts	Q'ty	Parts No.	Assembly No.	Ref. No.	Name of Parts	Q'ty	Parts No.	Assembly No.
Y- 1	Vinyl Bag		122991-0-01		Y-20	Chain Assembly		142262-0-01	
Y- 2	Wrench		140342-0-01		Y-21	Needle Bag			
Y- 3	Wrench		105343-0-01		Y-22	Needle DC×1		112297-	
Y- 4	Spanner 6×7		107779-0-01		Y-23	Needle Bag			
Y- 6	Spanner 3		142721-0-01		Y-24	Needle DM×13		140104-	
Y- 7	Screw Driver		144124-0-01		Y-25	Threadle Pedal		147893-0-01	
Y- 8	Allen Driver Wrench		146700-0-01		Y-26	Pedal Stopper		116016-0-01	
Y- 9	Screw Driver		118837-0-01		Y-27	Nut		021400-1-06	
Y-10	Screw Driver		101572-1-01		Y-28	Screw		001401-4-06	
Y-11	Tweezers		117466-0-00		Y-29	Funnel		140759-0-00	
Y-12	Threader		142125-0-00		Y-30	Upper Knife		148198-0-01	
Y-13	Screw		031311-3-02		Y-31	Screw		141542-0-01	
Y-14	Duster Drop		148430-0-01		Y-32	Trimming Knife		148259-0-01	
Y-15	Washer		025680-2-32		Y-33	Lower Knife		112436-0-01	
Y-16	Screw		031451-6-03		Y-34	Head Cover		144225-0-01	
Y-17	Duster Shoot (L)		148431-0-01		Y-35	Oiler		114483-0-01	
Y-18	Duster Shoot (S)		148432-0-01		Y-36	Oil Tank		145277-0-01	
Y-19	Table Sheet		149005-0-01						

\* The details of included accessories are subject to change.

\* Änderungen in der Aufstellung der mitgelieferten Zubehöre sind vorbehalten.

\* Les détails des accessoires inclus sont sujets à des changements.

\* Los detalles de los accesorios incluidos pueden variar.

# DIFFERENT PARTS LIST

Model	Sub-Class	No. of Needles	No. of Thread	Needle Gauge	Sewing Width	Max. Stitch	Differential Ratio	Presser Foot	Feed Dog		Needle Size	Sewing Speed	Front Cover Assembly		Supporter for Front Cover Assembly		Needle Clamp Assembly		Needle DC	
									Pitch	Type										
B-581	061-3 5	2	5	2	3 5	3.6	0.3-1.8	4	1.6		#11	5000	A-34 A-38 A-79	148987-001	A-28 A-29	146444-001	B-11 B-12	146487-001	B-13 B-14	112297-011 140104-011
	062-3	2	4	2	3	3.6	0.3-1.8	4	1.6		#11	5000	A-34 A-38 A-79	148987-001	A-28 A-29	146444-001	B-11 B-12	146487-001	B-13 B-14	112297-011 140104-011
	063-5	2	5	3	5	3.6	0.3-1.8	6	1.6		#14	5000	A-34 A-38 A-79	148987-001	A-28 A-29	146444-001	L-14 L-15	146489-001	L-16 L-17	112297-014 140104-014
	064-5	2	4	3	5	3.6	0.3-1.8	6	1.6		#14	5000	A-34 A-38 A-79	148987-001	A-28 A-29	146444-001	M-14 M-15	146489-001	M-16 M-17	112297-014 140104-014
	065-5	2	5	5	5	3.6	0.3-1.8	6	1.6		#16	5000	A-34 A-38 A-79	148987-001	A-28 A-29	146444-001	N-14 N-15	146491-001	N-16 N-17	112297-016 140104-016
	066-5	2	4	5	5	3.6	0.3-1.8	6	1.6		#16	5000	A-34 A-38 A-79	148987-001	A-28 A-29	146444-001	P-14 P-15	146491-001	P-16 P-17	112297-016 140104-016
	067-4	2	5	2	4	3.3	0.3-2.7	5	1.6		#14	5000	A-34 A-38 A-79	148101-001	A-28 A-29	146444-001	B-11 B-12	146487-001	Q-19 Q-20	112297-014 140104-014
	069-5	2	5	3	5	3.3	0.3-2.7	5	1.6		#14	5000	A-34 A-38 A-79	148101-001	A-28 A-29	146444-001	R-21 R-22	146489-001	R-19 R-20	112297-014 140104-014
	071-6	2	5	5	6	3.3	0.3-2.7	5	1.6		#14	5000	A-34 A-38 A-79	148101-001	A-28 A-29	146444-001	S-21 S-22	146491-001	S-19 S-20	112297-014 140104-014
	073-4	2	5	2	4	3.3	0.3-2.7	5	1.6		#14	5000	A-34 A-38 A-79	148101-001	A-28 A-29	146444-001	B-11 B-12	146487-001	T-19 T-20	112297-014 140104-014
	075-5	2	5	3	5	3.3	0.3-2.7	5	1.6		#14	5000	A-34 A-38 A-79	148101-001	A-28 A-29	146444-001	U-21 U-22	146489-001	U-19 U-20	112297-014 140104-014
	077-6	2	5	5	6	3.3	0.3-2.7	5	1.6		#14	5000	A-34 A-38 A-79	148101-001	A-28 A-29	146444-001	V-21 V-22	146491-001	V-19 V-20	112297-014 140104-014
	081-5	2	5	3	5	3.6	0.3-1.8	6	1.6		#14	5000	A-34 A-38 A-79	148987-001	A-28 A-29	146444-001	W-16 W-17	146489-001	W-15 W-14	112297-014 140104-014
	087-6	2	5	5	6	3.6	0.3-1.8	6.5	2.5		#21	5000	A-34 A-38 A-79	148987-001	A-28 A-29	146444-001	W-1 W-2	146491-001	W-3 W-4	112297-021 140104-021
	089-5	2	5	3	5	3.6	0.3-1.8	6	1.6		#14	5000	a-36 a-40 a-46	148989-001	a-32 a-33	147367-001	a-15 a-16	146489-001	B-13 B-14	112297-014 140104-014
092-6	2	5	5	6	3.0	0.3-1.8	3.5	2.5		#21	5000	A-34 A-38 A-79	148987-001	A-28 A-29	146444-001	b-1 b-2	146491-001	b-3 b-4	112297-021 140104-021	

Model	Sub-Class	Needle Plate	Presser Foot Assembly		Main Feed Dog		Differential Feed Dog		Chain Feed Dog		Over Looper Assembly		Over Looper		Needle Thread Take-up		Washer	
B-581	061-3 -5	B-67 146498-001	F-59 F-67	148155-001	E-43	146567-001	E-40	146572-001	E-42	146577-001	C-37 C-45 C-61	148209-001	C-46 C-47	147934-001	G-6	144108-001	G-7	105248-003
	062-3	B-67 146498-001	F-59 F-67	148155-001	E-43	146567-001	E-40	146572-001	E-42	146577-001	C-37 C-45 C-61	148209-001	K-2 K-3	147935-001	K-1	142201-001		
	063-5	L-18 146503-001	L-1 L-13	148150-001	E-43	146567-001	E-40	146572-001	E-42	146577-001	C-37 C-45 C-61	148209-001	C-46 C-47	147934-001	G-6	144108-001	G-7	105248-003
	064-5	M-18 146503-001	M-1 M-13	148150-001	E-43	146567-001	E-40	146572-001	E-42	146577-001	C-37 C-45 C-61	148209-001	M-20 M-21	147935-001	M-19	142201-001		
	065-5	N-18 146504-001	N-1 N-13	148153-001	N-19	146568-001	N-20	146573-001	E-42	146577-001	C-37 C-45 C-61	148209-001	C-46 C-47	147934-001	G-6	144108-001	G-7	105248-003
	066-5	P-18 146504-001	P-1 P-13	148153-001	N-19	146568-001	P-20	146573-001	E-42	146577-001	C-37 C-45 C-61	148209-001	P-21 P-22	147935-001	P-23	142201-001		
	067-4	Q-14 146507-001	Q-1 Q-13	148158-001	Q-16	148190-001	Q-17	146575-001	Q-15	148189-001	C-37 C-45 C-61	148209-001	G-46 C-47	147934-001	G-6	144108-001	G-7	105248-003
	069-5	R-14 146508-001	R-1 R-13	148160-001	R-16	148190-001	R-17	146575-001	R-15	148189-001	C-37 C-45 C-61	148209-001	C-46 C-47	147934-001	G-6	144108-001	G-7	105248-003
	071-6	S-14 146509-001	S-1 S-13	148161-001	S-16	148191-001	S-17	146576-001	S-15	148189-001	C-37 C-45 C-61	148209-001	C-46 C-47	147934-001	G-6	144108-001	G-7	105248-003
	073-4	T-14 146507-001	T-1 T-13	148747-001	T-16	148750-001	T-17	146575-001	T-15	148189-001	C-37 C-45 C-61	148209-001	C-46 C-47	147934-001	G-6	144108-001	G-7	105248-003
	075-5	U-14 146508-001	U-1 U-13	148748-001	U-16	148751-001	U-17	146575-001	U-15	148189-001	C-37 C-45 C-61	148209-001	C-46 C-47	147934-001	G-6	144108-001	G-7	105248-003
	077-6	V-14 146509-001	V-1 V-13	148749-001	V-16	148752-001	V-17	146576-001	V-15	148189-001	C-37 C-45 C-61	148209-001	C-46 C-47	147934-001	G-6	144108-001	G-7	105248-003
	081-5	W-20 146503-001	W-1 W-13	148162-001	E-43	146567-001	E-40	146572-001	E-42	146577-001	C-37 C-45 C-61	148209-001	C-46 C-47	147934-001	G-6	144108-001	G-7	105248-003
	087-6	W-14 146510-001	W-5 W-13	148260-001	W-15	146569-001	W-16	146574-001	E-42	146577-001	W-18 W-27	148217-001	W-30 W-31	147937-001	G-6	144108-001	G-7	105248-003
089-5	a-14 147369-001	a-1 a-13	148263-001	E-43	146567-001	E-40	146572-001	E-42	146577-001	C-37 C-45 C-61	148209-001	C-46 C-47	147934-001	G-6	144108-001	G-7	105248-003	
092-6	b-14 146510-001	b-5 b-13	148260-001	b-15	146569-001	b-16	146574-001	E-42	146577-001	b-18 b-27	148217-001	b-30 b-31	147937-001	G-6	144108-001	G-7	105248-003	

Of Cap	Threading Diagram	Level	Level	Ruffling Attachment Assembly	Screw	Ruffler Guide	Screw	Lapper
A 27	111865 001	A 33 148104 001	A 19 146976 001	A 42 147943 001				
A-27	111865-001	K 4 148105 001	K-5 146976 004					
A-27	111865-001	A 33 148104 001	L-19 146976 009	A 42 147943 001				
A-27	111865 001	M 22 148105 001	M 23 146976 012					
A 27	111865 001	A 33 148104 001	N 21 146976 013	A 42 147943 001				
A 27	111865 001	P 24 148105 001	P 25 146976 016					
		A 33 148104 001	Q-18 146976 019	A 42 147943 001	Q 21 146587 001 Q 52	Q 53 009781 812	Q 54 144793 000	Q 55 112751 002
		A 33 148104 001	R 18 146976 021	A 42 147943 001	R 23 146587 001 R 54	R 55 009781 812	R 56 144793 000	R 57 112751 002
		A 33 148104 001	S 18 146976 023	A 42 147943 001	S 23 146587 001 S 54	S 55 009781 812	S 56 144793 000	S 57 112751 002
		A 33 148104 001	T 18 146976 025	A 42 147943 001	T 21 146587 001 T 52	T 53 009781 812	T 54 144793 000	T 55 112751 002 T 58 147440 000
		A 33 148104 001	U 18 146976 027	A 42 147943 001	U 23 146587 001 U 54	U 55 009781 812	U 56 144793 000	U 57 112751 002 U 60 147440 000
		A-33 148104 001	V-18 146976 029	A-42 147943 001	V 23 146587 001 V 54	V 55 009781 812	V 56 144793 000	V 57 112751 002 V 60 147440 000
A 27	111865 001	A 33 148104 001	W 21 146976 039	A 42 147943 001				
A 27	111865 001	A 33 148104-001	W 17 146976 051	A 42 147943 001				
A 27	111865 001	A 33 148104 001	a 43 146976 069	A 42 147943 001				
A-27	111865-001	A-33 148104-001	b 17 146976 090	A 42 147943 001				

Model	Sub-Class	Screw	Spool Stand Assembly	Tape Winder Assembly	Screw	Lapper Assembly	Screw	Washer	Tape Guide	Screw					
B 581	061-3	/	/	/	/	/	/	/	/	/					
	-5	/	/	/	/	/	/	/	/	/					
	062-3	/	/	/	/	/	/	/	/	/					
	063-5	/	/	/	/	/	/	/	/	/					
	064-5	/	/	/	/	/	/	/	/	/					
	065-5	/	/	/	/	/	/	/	/	/					
	066-5	/	/	/	/	/	/	/	/	/					
	067-4	/	/	/	/	/	/	/	/	/					
	069-5	/	/	/	/	/	/	/	/	/					
	071-6	/	/	/	/	/	/	/	/	/					
	073-4	T-59	009680 612	X-1 181031 001 X-7	X-8 143767 002 X-16	a-26	101118 001	/	/	/	/				
	075-5	U-61	009680 612	X-1 181031 001 X-7	X-8 143767 002 X-16	a-26	101118 001	/	/	/	/				
	077-6	V-61	009680-612	X-1 181031 001 X-7	X-8 143767 002 X-16	a-26	101118-001	/	/	/	/				
	081-5	/	/	/	/	/	/	/	/	/	/				
	087-6	/	/	/	/	/	/	/	/	/	/				
089-5	/	/	/	a-17 143767 002 a-25	a-26	101118 001	a-27 147373 000 a-30	a-31	009670 512	a-41	025350 332	a-34	147377 001	a-35	009670 512
092-6	/	/	/	/	/	/	/	/	/	/	/	/	/	/	/

Washer	Handle	Nut	Tape Guide	Screw	Spring	Upper Knife	Bolt	Upper Knife Holder								
					G-18	144104-001	F-42	148198-001	F-41	144075-001	F-43	144179-001				
					G-18	144104-001	F-42	148198-001	F-41	144075-001	F-43	144179-001				
					G-18	144104-001	F-42	148198-001	F-41	144075-001	F-43	144179-001				
					G-18	144104-001	F-42	148198-001	F-41	144075-001	F-43	144179-001				
					G-18	144104-001	F-42	148198-001	F-41	144075-001	F-43	144179-001				
					G-18	144104-001	F-42	148198-001	F-41	144075-001	F-43	144179-001				
					G-18	144104-001	F-42	148198-001	F-41	144075-001	F-43	144179-001				
	Q-56	145809-001	Q-57	021780-303					G-18	144104-001	F-42	148198-001	F-41	144075-001	F-43	144179-001
	R-58	145809-001	R-59	021780-303					G-18	144104-001	F-42	148198-001	F-41	144075-001	F-43	144179-001
	S-58	145809-001	S-59	021780-303					G-18	144104-001	F-42	148192-001	F-41	144075-001	F-43	144179-001
	T-56	145809-001	T-57	021780-303					G-18	144104-001	F-42	148192-001	F-41	144075-001	F-43	144179-001
	U-58	145809-001	U-59	021780-303					G-18	144104-001	F-42	148192-001	F-41	144075-001	F-43	144179-001
	V-58	145809-001	V-59	021780-303					G-18	144104-001	F-42	148192-001	F-41	144075-001	F-43	144179-001
					W-18	146883-001	W-19	009669-412	G-18	144104-001	F-42	148192-001	F-41	144075-001	F-43	144179-001
									W-32	148851-001	F-42	148192-001	F-41	144075-001	F-43	144179-001
a-42	025350-332								G-18	144104-001	F-42	148192-001	F-41	144075-001	F-43	144179-001
									b-32	148851-001	b-34	148342-001			b-33	148345-001





# INDEX

Parts No.	Ref. No.	Remark	Parts No.	Ref. No.	Remark	Parts No.	Ref. No.	Remark	Parts No.	Ref. No.	Remark
001401-4-06	Y-28		009680-6-12	R-47		017761-6-12	F-37		101118-0-01	X-17	
001630-4-02	G-45		"	S-42		"	W-28		101572-1-01	Y-10	
"	G-48		"	S-47		"	b-24		101706-0-01	A-63	
001670-5-12	Q-41		"	T-40		017771-4-12	D-10		"	Q-27	
"	R-43		"	T-45		017771-6-12	A-45		"	Q-28	
"	S-43		"	T-59		"	C-56		"	R-29	
"	T-41		"	U-42		"	F-52		"	R-30	
"	U-43		"	U-47		018061-6-22	B-75		"	S-29	
"	V-43		"	U-61		021400-1-06	Y-27		"	S-30	
009630-6-12	D-1		"	V-42		021670-2-02	B-77		"	T-27	
009630-8-12	E-41		"	V-47		021680-2-02	F-9		"	T-28	
009639-3-12	F-60		"	V-61		021760-3-03	Q-52		"	U-29	
"	F-62		009680-7-12	A-52		"	R-54		"	U-30	
009660-6-12	b-9		"	A-77		"	S-54		"	V-29	
009660-7-12	Q-12		"	B-31		"	T-52		"	V-30	
"	Q-22		"	B-35		"	U-54		101706-0-03	D-14	
"	R-12		"	B-68		"	V-54		"	E-28	
"	R-23		"	C-62		021780-3-03	Q-57		102424-0-03	b-37	
"	S-12		"	E-53		"	R-59		102538-0-02	B-39	
"	S-23		"	F-14		"	S-59		102627-0-01	F-54	
"	T-12		"	F-58		"	T-57		102843-0-04	A-8	
"	T-21		009680-7-14	A-1		"	U-59		"	B-46	
"	U-12		009680-8-12	Q-49		"	V-59		"	B-50	
"	U-23		"	R-51		025350-3-32	a-41		104908-0-01	F-20	
"	V-12		"	S-51		"	a-42		105163-0-01	Q-44	
"	V-23		"	T-49		025630-2-32	G-44		"	R-46	
009669-3-12	G-5		"	U-51		"	G-47		"	S-46	
009669-4-12	B-5		"	V-51		025680-2-32	Y-15		"	T-44	
"	B-71		009681-0-12	B-58		025770-2-32	Q-35		"	U-46	
"	F-68		009681-2-12	A-17		"	R-37		"	V-46	
"	G-55		009681-4-12	F-10		"	S-37		105230-0-01	G-64	
"	W-19		"	G-21		"	T-35		105234-0-03	Q-29	
009670-4-12	A-31		009781-8-12	Q-53		"	U-37		"	R-31	
"	G-52		"	R-55		"	V-37		"	S-31	
009670-5-12	C-1		"	S-55		028050-2-42	X-5		"	T-29	
"	C-19		"	T-53		028350-2-43	G-51		"	U-31	
"	C-28		"	U-55		031311-3-02	Y-13		"	V-31	
"	C-48		"	V-55		031451-6-03	Y-16		105248-0-03	G-7	
"	C-57		013679-4-12	O-50		034151-6-03	Z-4		105288-0-01	L-7	
"	F-25		"	R-52		047140-8-42	A-37		"	L-10	
"	a-31		"	S-52		047140-8-42	a-38		"	M-7	
"	a-35		"	T-50		048020-3-42	L-12		"	M-10	
009670-6-12	A-7		"	U-52		"	M-12		"	N-7	
"	A-9		"	V-52		"	N-12		"	N-10	
"	A-40		013760-6-12	A-74		"	P-12		"	P-7	
"	A-48		"	C-14		"	W-4		"	P-10	
"	A-54		013761-4-10	B-56		"	W-11		"	Q-10	
"	A-60		014680-4-22	A-22		"	a-11		"	R-10	
"	A-67		"	C-9		072600-0-00	B-42		"	S-10	
"	A-70		"	C-23		072600-1-00	B-53		"	T-10	
"	F-47		"	C-45		"	B-60		"	U-10	
"	G-8		"	C-47		"	B-62		"	V-10	
"	G-25		"	D-25		081002-6-70	F-17		"	W-8	
"	G-34		"	G-54		100022-0-05	F-21		"	W-12	
"	G-39		"	K-3		100032-0-03	A-58		"	W-6	
"	G-57		"	M-21		"	B-66		"	W-9	
"	G-66		"	P-22		100080-0-02	X-3		"	a-7	
"	G-69		"	W-22		100136-0-01	a-25		"	a-10	
009670-8-12	B-8		"	W-35		"	X-15		105343-0-01	Y-3	
"	B-38		"	b-18		100260-0-01	C-32		106568-0-01	A-55	
"	C-24		"	b-31		"	F-30		106720-0-02	A-69	
"	G-10		017751-4-12	C-21		100366-0-01	B-19		107244-0-01	B-64	
"	G-12		"	D-23		"	B-20		107351-0-01	B-74	
"	G-38		017761-4-12	D-20		"	B-26		107407-0-03	A-39	
009671-0-14	b-38		"	E-7		"	B-81		"	E-38	
009671-4-12	B-76		"	E-14		"	E-22		"	E-45	
009680-6-12	Q-40		"	E-25		100444-0-02	X-2		"	F-44	
"	Q-45		017761-6-12	B-24		100447-0-01	X-7		"	F-51	
"	R-42		"	C-39		101118-0-01	a-26		107779-0-01	Y-4	

Parts No.	Ref. No.	Remark	Parts No.	Ref. No.	Remark	Parts No.	Ref. No.	Remark	Parts No.	Ref. No.	Remark
108494-0-01	a -23		113589-0-01	A -15		140273-0-01	Q - 4		144049-0-01	C -26	
"	X -13		114255-0-02	B -15		"	R - 4		144075-0-01	F -41	
108495-0-01	a -24		114483-0-01	Y -35		"	S - 4		144103-0-02	G -17	
"	X -14		116016-0-01	Y -26		"	T - 4		"	G -29	
108809-0-01	C -36		116231-0-01	E - 9		"	U - 4		144104-0-01	G -18	
"	W-32		"	E -15		"	V - 4		144105-0-00	G -19	
"	b -28		117160-0-01	A -30		140275-0-01	Q - 5		"	G -27	
109203-0-01	A -44		117466-0-00	Y -11		"	R - 5		"	G -63	
109852-0-01	X - 4		117515-0-01	F -45		"	S - 5		"	Q -33	
109853-0-01	X - 1		117516-0-01	E -39		"	T - 5		"	R -35	
109854-0-01	X -1 ~ 5		"	E -44		"	U - 5		"	S -35	
110161-0-03	X - 6		"	F -46		"	V - 5		"	T -33	
110230-0-01	Q -30		117591-0-01	D -18		140289-0-01	G -67		"	U -35	
"	R -32		117608-0-01	B -72		140290-0-01	G -53		"	V -35	
"	S -32		118768-0-01	B -32		140313-0-01	D - 9		144106-0-02	G -20	
"	T -30		118837-0-01	Y - 9		140327-0-01	D -11		"	G -26	
"	U -32		122771-0-02	G -41		140342-0-01	Y - 2		"	Q -32	
"	V -32		"	L - 4		140759-0-00	Y -29		"	R -34	
110641-0-01	A -43		"	M - 4		140774-0-00	E -30		"	S -34	
110670-0-00	B -59		"	N - 4		"	E -54		"	T -32	
110672-0-00	B -61		"	P - 4		140992-0-01	Q - 1		"	U -34	
110673-0-00	B -63		"	W-10		"	R - 1		"	V -34	
110807-0-02	b -10		"	W: 4		"	S - 1		144108-0-01	G - 6	
110813-0-01	G -33		"	a - 4		"	T - 1		144110-0-01	G -28	
"	G -59		122991-0-01	Y - 1		"	U - 1		144124-0-01	Y - 7	
"	G -70		140041-0-01	A - 5		"	V - 1		144127-0-01	C -25	
110820-0-01	G -14		140065-0-01	E - 1		140993-0-01	Q - 2		144179-0-01	F -43	
"	G -32		140066-0-01	B -28		"	R - 2		144225-0-01	Y -34	
"	Q -36		"	C -29		"	S - 2		144458-0-01	C -10	
"	R -38		140077-0-01	A -50		"	T - 2		144764-0-01	Q -42	
"	S -38		140084-0-00	B -65		"	U - 2		"	R -44	
"	T -36		140085-0-03	B -57		"	V - 2		"	S -44	
"	U -38		140092-0-01	B -18		141183-0-00	A -65		"	T -42	
"	V -38		"	B -25		141393-0-01	F -70		"	U -44	
110832-0-01	G -15		140104 -	Y -24		141528-0-01	F - 8		"	V -44	
"	G -31		140104-0-11	B -14		141542-0-01	Y -31		144778-0-01	Q -11	
"	G -60		140104-0-14	L -17		142125-0-00	Y -12		"	R -11	
111486-0-01	B -78		"	M -17		142201-0-01	K - 1		"	S -11	
111865-0-01	A -27		"	Q -20		"	M -19		"	T -11	
112297 -	Y -22		"	R -20		"	P -23		"	U -11	
112297-0-11	B -13		"	S -20		142243-0-01	F -64		"	V -11	
112297-0-14	L -16		"	T -20		142244-0-01	F -61		144783-0-01	Q -21	
"	M -16		"	U -20		142245-0-01	F -59		"	R -25	
"	Q -19		"	V -20		142246-0-01	F -65		"	S -25	
"	R -19		"	W -14		142247-0-01	F -66		"	T -23	
"	S -19		"	a -45		142262-0-01	Y -20		"	U -25	
"	T -19		140104-0-16	N -17		145290-0-01	C - 3		"	V -25	
"	U -19		"	P -17		"	C - 7		144784-0-01	Q -23	
"	V -19		140104-0-21	W:21		"	C -54		"	R -24	
"	W -15		"	b - 4		142658-0-01	C -50		"	S -24	
"	a -44		140180-0-01	B -55		142669-0-01	G -42		"	T -22	
112297-0-16	N -16		140208-0-01	E -34		142674-0-00	E -31		"	U -24	
112297-0-21	W-20		"	E -57		"	E -58		"	V -24	
"	b - 3		140248-0-01	F -57		142721-0-01	Y - 6		144788-0-01	Q -34	
112299-0-01	G - 3		140270-0-01	N -13		143312-0-00	B -41		"	R -36	
112300-0-01	G - 2		"	P -13		143374-0-01	A -75		"	S -36	
112301-0-01	G - 4		"	Q - 6		143444-0-01	C -15		"	T -34	
112436-0-01	F -49		"	R - 6		143750-0-02	a -22		"	U -36	
"	Y -33		"	S - 6		"	X -16		"	V -36	
112751-0-02	Q -55		"	T - 6		143757-0-01	G - 9		144793-0-00	Q -54	
"	R -57		"	U - 6		143767-0-02	a -18~25		"	R -56	
"	S -57		"	V - 6		"	X - 9~16		"	S -56	
"	T -55		"	W:12		143976-0-01	a -20 - 21		"	T -54	
"	U -57		140272-0-01	Q - 9		"	X -11 - 12		"	U -56	
"	V -57		"	R - 9		143978-0-01	a -18 - 19		"	V -56	
112754-0-01	B -37		"	S - 9		"	X - 9 - 10		145147-0-01	L - 8	
112797-0-16	P -16		"	T - 9		143980-0-01	a -17		"	M - 8	
113431-0-02	E -37		"	U - 9		"	X - 8		"	N - 8	
"	E -46		"	V - 9		144031-0-00	C -35		"	P - 8	

Parts No.	Ref. No.	Remark	Parts No.	Ref. No.	Remark	Parts No.	Ref. No.	Remark	Parts No.	Ref. No.	Remark
145147-0-01	W-13		146483-0-01	B - 9		146634-0-01	D -24		147377-0-01	a -34	
"	W-10		146486-0-00	B -10		146635-0-01	D -26		147440-0-00	T -38	
145277-0-01	Y -36		146487-0-01	B -11 - 12		146644-0-00	B -29		"	U -60	
145446-0-01	G -16		146489-0-01	L -14 - 15		146649-0-01	G -13		"	V -60	
"	G -30		"	M-14 - 15		146652-0-01	G -36		147691-0-00	B -33	
"	G -61		"	R -21 - 22		146653-0-01	G -37		"	B -34	
145803-0-01	Q -24		"	U -21 - 22		146654-0-01	G -40		147893-0-01	Y -25	
"	R -26		"	W-16 - 17		146662-0-01	G -50		147919-0-01	Z - 1	
"	S -26		"	a -15 - 16		146663-0-01	G -43		147919-0-02	Z - 2	
"	T -24		146491-0-01	N -14 - 15		146700-0-01	Y - 8		147933-0-01	Q -37	
"	U -26		"	P -14 - 15		146865-0-01	L -13		"	R -39	
"	V -26		"	S -21 - 22		"	M-13		"	S -39	
145807-0-01	Q -48		"	V -21 - 22		"	W - 5		"	T -37	
"	R -50		"	W-18 - 19		"	a -12		"	U -39	
"	S -50		"	b - 1 - 2		146868-0-01	L - 6		"	V -39	
"	T -48		146498-0-01	B -67		"	M- 6		147934-0-01	C -46 - 47	
"	U -50		146503-0-01	L -18		"	N - 6		147935-0-01	K - 3 - 4	
"	V -50		"	M-18		"	P - 6		"	M-20 - 21	
145808-0-01	Q -46		"	W-20		"	W-11		"	P -21 - 22	
"	R -48		146504-0-01	N -18		"	W- 7		147943-0-01	A -42	
"	S -48		"	P -18		"	a - 6		147973-0-01	W-34 - 35	
"	T -46		146507-0-01	Q -14		146870-0-01	L - 5		"	b -30 - 31	
"	U -48		"	T -14		"	M- 5		148015-0-01	b - 6	
"	V -48		146508-0-01	R -14		"	N - 5		148016-0-01	b - 7	
145809-0-01	Q -56		"	U -14		"	P - 5		148017-0-01	b -12	
"	R -58		146509-0-01	S -14		"	W - 9		148020-0-01	b -11	
"	S -58		"	V -14		"	W - 5		148065-0-01	A -16	
"	T -56		146510-0-01	W-14		"	a - 5		148066-0-00	A -18	
"	U -58		"	b -14		146879-0-01	Q - 7		148067-0-01	A - 2	
"	V -58		146547-0-00	E -51		"	T - 7		148068-0-00	A - 3	
145811-0-01	Q -39		146549-0-01	E -52		146883-0-01	W-18		148069-0-01	A -72	
"	R -41		146567-0-01	E -43		146901-0-01	L - 3		148070-0-01	A -76	
"	S -41		146568-0-01	N -19		"	M - 3		148071-0-00	A -73	
"	T -39		"	P -19		"	N - 3		148072-0-01	A -71	
"	U -41		146569-0-01	W-15		"	P - 3		148073-0-01	A -12	
"	V -41		"	b -15		"	W - 3		148074-0-01	A - 6	
146315-0-00	A -62		146572-0-01	E -40		"	W- 2		148075-0-00	A - 4	
146421-0-00	A -14		146573-0-01	N -20		"	a - 3		148076-0-01	A -66	
146426-0-00	A -11		"	P -20		146924-0-00	A -29		148077-0-01	A -61	
146427-0-01	A -10		146574-0-01	W-16		"	a -33		148078-0-01	A -49	
"	A -68		"	b -16		146926-0-01	G -24		148082-0-01	A -57	
"	B - 2		146575-0-01	Q -17		"	G -68		148083-0-01	A -56	
"	B -12		"	R -17		146928-0-01	G -49		148084-0-01	A -23	
"	C -40		"	T -17		146929-0-01	G -35		148085-0-01	A -26	
"	D -21		"	U -17		146930-0-01	G -56		148086-0-00	B -43	
"	F - 2		"	V -17		146976-0-01	A -19		148087-0-01	A -46	
"	L -15		146576-0-01	S -17		146976-0-04	K - 5		148088-0-00	A -47	
"	M -15		146577-0-01	E -42		146976-0-09	L -19		148089-0-01	A -59	
"	N -15		146580-0-01	F -39		146976-0-12	M -23		148090-0-01	A -51	
"	P -15		146581-0-01	C -33		146976-0-13	N -21		148101-0-01	A -34 ~ 38	
"	R -22		"	F -31		146976-0-16	P -25		148103-0-01	A -41	
"	S -22		146582-0-01	F -53		146976-0-19	Q -18		148104-0-01	A -33	
"	U -22		146583-0-01	F -50		146976-0-21	R -18		148105-0-01	K - 4	
"	V -22		146584-0-01	F -55		146976-0-23	S -18		"	M-22	
"	W -16		146585-0-01	F -48		146976-0-25	T -18		"	P -24	
"	W -19		146586-0-00	F -56		146976-0-27	U -18		148111-0-00	B -54	
"	W -27		146587-0-01	Q -21 ~ 52		146976-0-29	V -18		148112-0-00	B -52	
"	a -16		"	R -23 ~ 54		146976-0-39	W -21		148113-0-01	B -51	
"	b - 2		"	S -23 ~ 54		146976-0-51	W -17		148120-0-00	B -27	
"	b -23		"	T -21 ~ 52		146976-0-69	a -43		148121-0-00	B -17	
146440-0-01	A -36		"	U -23 ~ 54		146976-0-90	b -17		148123-0-01	B -16	
"	a -39		"	V -23 ~ 54		147148-0-01	G -58		148124-0-01	B -73	
146441-0-00	A -38		146592-0-01	Q -51		147149-0-01	G -62		148125-0-01	B -70	
"	a -37		"	R -53		147272-0-01	G -46		148126-0-01	B -69	
146442-0-01	A -35		"	S -53		147344-0-01	G - 1		148128-0-01	F -11	
"	a -40		"	T -51		147367-0-01	a -32 - 33		148129-0-01	F -12	
146444-0-01	A -28 - 29		"	U -53		147369-0-01	a -14		148130-0-01	F -13	
146446-0-01	A -32		"	V -53		147371-0-01	a - 8		148131-0-01	F -18 - 19	
146472-0-01	B -40		146617-0-01	C -22		147373-0-00	a -27 - 30		148133-0-01	F -19	

Parts No.	Ref. No.	Remark	Parts No.	Ref. No.	Remark	Parts No.	Ref. No.	Remark	Parts No.	Ref. No.	Remark
148134-0-01	F-16		148208-0-01	C-34		148783-0-01	b-27				
148135-0-01	F-15		148209-0-01	C-37~45		148813-0-01	F-24				
148136-0-01	F-29		148217-0-01	W-22~31		148838-0-01	E-12				
148137-0-01	F-27		"	b-18~27		148847-0-01	E-11				
148138-0-01	F-28		148224-0-01	C-2		"	E-13				
148139-0-01	F-26		148225-0-01	B-45		148851-0-01	W-32				
148143-0-01	F-7		148226-0-01	C-11		"	b-32				
148144-0-01	F-4		148227-0-00	C-12		148857-0-01	C-5				
"	F-6		148228-0-00	C-20		"	C-52				
148145-0-01	F-5		148230-0-01	B-3~8		"	D-5				
148146-0-01	F-3		148232-0-01	C-16		"	E-26				
148147-0-01	F-1		148233-0-01	D-4		"	B-48				
148148-0-01	F-69		148234-0-00	D-3		148858-0-01	B-20~23				
148150-0-01	L-1~13		148235-0-01	D-2		"	B-47				
"	M-1~13		148236-0-01	D-6		"	B-79~82				
148152-0-01	L-2		148237-0-00	D-7		148859-0-00	A-78				
"	M-2		148239-0-01	D-15		149005-0-01	Y-19				
"	N-2		148240-0-01	D-17		150162-0-01	Z-8				
"	P-2		148241-0-01	D-19		180323-0-01	C-13-14				
"	W-2		148242-0-01	C-17		181031-0-01	X-1~7				
"	W-3		148243-0-01	D-16		181628-0-01	C-51-52				
"	a-2		148244-0-00	D-12		181629-0-01	B-4-5				
148153-0-01	N-1~13		148245-0-00	D-22		181630-0-01	B-3				
"	P-1~13		148247-0-01	B-36		"	B-6-7				
"	W-1~13		148248-0-00	E-2		181631-0-01	C-50				
148155-0-01	F-59~67		148249-0-00	C-59		"	C-53-54				
148158-0-01	Q-1~13		"	W-33		"	D-10				
148160-0-01	R-1~13		"	b-29		181995-0-01	D-13-14				
148161-0-01	S-1~13		148250-0-01	C-58		"	E-28-29				
148162-0-01	W-1~13		148251-0-01	C-27		181995-0-02	Q-26-27				
148163-0-01	E-21~24		148252-0-01	C-18		"	R-28-29				
148166-0-01	E-23		148253-0-01	G-22		"	S-28-29				
148167-0-01	E-3		148254-0-01	G-23		"	T-26-27				
148168-0-00	E-4		148255-0-01	G-11		"	U-28-29				
148170-0-01	E-49-50		148256-0-01	G-65		"	V-28-29				
148173-0-00	E-48		148259-0-01	Y-32		181969-0-03	A-63-64				
148174-0-00	E-36		148260-0-01	b-5~13		025060-1-32	D-27				
148175-0-00	E-47		148262-0-01	E-48~50							
148176-0-01	E-27		148263-0-01	a-1~13							
148177-0-01	E-17		148264-0-01	a-36~40							
148178-0-01	E-16		148269-0-01	B-1~8							
148179-0-01	E-10		148281-0-01	F-40							
148180-0-01	E-8		148290-0-01	Z-3							
148181-0-01	E-5		148292-0-01	Z-5							
"	E-19		148304-0-01	A-53							
148182-0-01	E-18		148315-0-01	B-30							
148183-0-01	E-6		148342-0-01	b-34							
148184-0-00	E-32		148343-0-01	b-35							
148185-0-01	E-33		148344-0-01	b-36							
148186-0-01	E-35		148345-0-01	b-33							
"	E-56		148346-0-01	F-22~25							
148189-0-01	Q-15		148373-0-00	B-44							
"	R-15		148403-0-00	E-55							
"	S-15		148404-0-01	E-59							
"	T-15		148430-0-01	Y-14							
"	U-15		148431-0-01	Y-18							
"	V-15		148432-0-01	Y-17							
148190-0-01	Q-16		148747-0-01	T-1~13							
"	R-16		148748-0-01	U-1~13							
148191-0-01	S-16		148749-0-01	V-1~13							
148196-0-00	F-38		148750-0-01	T-16							
148197-0-00	F-32		148751-0-01	U-16							
148198-0-01	F-42		148752-0-01	V-16							
"	Y-30		148769-0-00	E-20							
148200-0-01	C-50~55		148782-0-01	C-60							
148201-0-01	C-49		"	D-29							
148205-0-01	B-49		148783-0-01	C-61							
148206-0-01	C-30		"	D-28							
148207-0-00	C-31		"	W-31							

