

MODEL : ACF-172-1790

List No : 1382-03

# PARTS LIST

Published:09/22/2017

## CONTENTS

---

FRAME & MECHANISM COVER COMPONENTS (1).....	1
FRAME & MECHANISM COVER COMPONENTS (2).....	5
FEED BODY COMPONENTS (1).....	9
FEED BODY COMPONENTS (2).....	13
FEED BODY COMPONENTS (3).....	15
STACKER COMPONENTS (1).....	17
STACKER COMPONENTS (2).....	21
PRESET COMPONENTS (1).....	25
PRESET COMPONENTS (2).....	29
PRESET COMPONENTS (3).....	31
AIR COMPONENTS .....	35
FRAME COMPONENTS .....	39
CONTROL BOX COMPONENTS .....	43
OPERATION PANEL COMPONENTS .....	47
WIRING DIAGRAM (1).....	49
WIRING DIAGRAM (2).....	53
ACCESSORIES COMPONENTS (1).....	55
ACCESSORIES COMPONENTS (2).....	57
OPTIONAL DEVICE COMPONENTS (1).....	59
OPTIONAL DEVICE COMPONENTS (2).....	61
LIST FOR INFORMATION OF CHANGE.....	63
HOW TO MAKE USE OF THIS PARTS LIST .....	64

FRAME & MECHANISM COVER COMPONENTS (1)

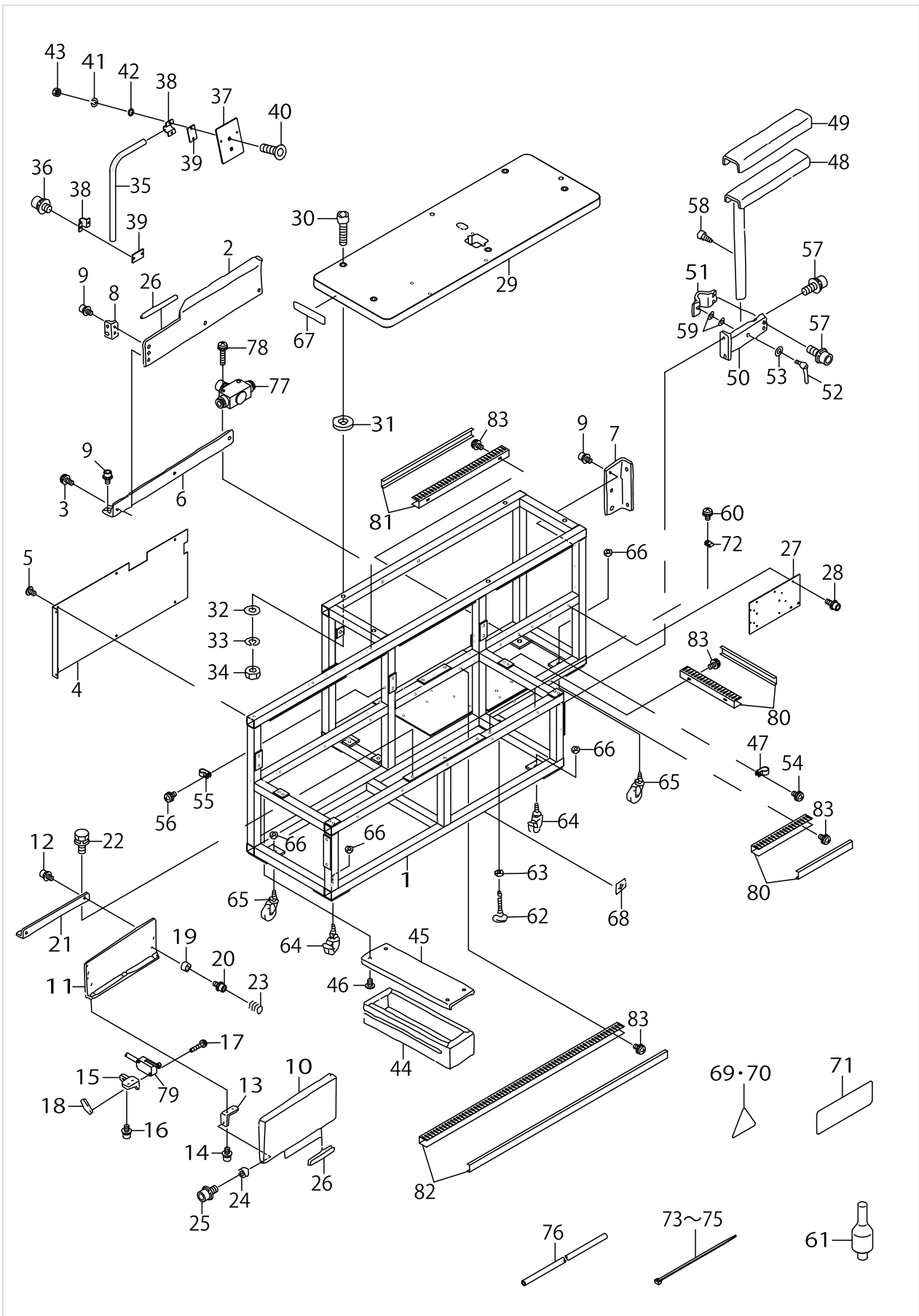

FRAME & MECHANISM COVER COMPONENTS (1)

No.	Parts No.	Parts name	Remarks	Level	Cons	Qty
1	40014271	FRAME				1
2	G5020172000	REAR COVER, TOP				1
3	SL4041091SC	SCREW M4 L=10				3
4	40019865	REAR_CIVER_LOWER				1
5	SM0040601SA	SCREW				6
6	G5022172000	REAR COVER SUPPORT, TOP				1
7	G5024172000	RIGHT COVER SUPPORT, LARGE				1
8	G5034171000	COVER SUPPORT				1
9	SL6040892TN	BOLT				8
10	G50051720A0	KNEE SWITCH				1
11	G5006172000	KNEE SWITCH SUPPORT				1
12	SL6040892TN	BOLT				2
13	G5007172000	KNEE SWITCH SHAFT HOLDER				2
14	SL6040892TN	BOLT				4
15	G5008172000	MICROSWITCH FITTING PLATE				1
16	SL6040892TN	BOLT				2
17	SL4031691SC	SCREW M3 L=16				2
18	13774906	SWITCH BASE				1
19	G5009172000	STOPPER RUBBER				3
20	SL6040842TN	SCREW M4 L=8				3
21	G5010172000	KNEE SWITCH FITTING PLATE				1
22	SL9061693SE	WASHER HEXAGONAL BOLT M6 L=16				3
23	B3207470000	SPRING				2
24	B2544280000	WASHER, FOR WORK CLAMP FOOT HO				2
25	SL6061292TN	SCREW				2
26	GBR01910000	RUBBER CUSHION				3
27	40011422	SV-BASE				1
28	SL6041092TN	SCREW				3
29	40011321	TABLE_ACF				1
30	MTJMS000030	SCREW				5
31	22573505	PACKING				5
32	WP0852086SC	WASHER M8				5
33	WS0820002KN	SPRING WASHER M8				5
34	NS6200710SN	NUT 5/16-18				5
35	G1017192000	STAND				1
36	SL6061692TN	BOLT				2
37	40011423	PANEL_PLATE				1
38	G1015192000	CLAMP				2
39	G1016192000	CLAMP BOTTOM PLATE				2
40	SM1062052TP	SCREW M6 L=20				2
41	WS0610002KN	SPRING WASHER 6.1X12.2X1.5				2
42	WP0641601SC	WASHER				2
43	NM6060001SC	NUT M6				2
44	11155108	DRAWER				1
45	G5011172000	DRAWING RAIL				1
46	SM0040601SA	SCREW				4
47	HX00150000F	CABLE CLIP				3

FRAME & MECHANISM COVER COMPONENTS (1)

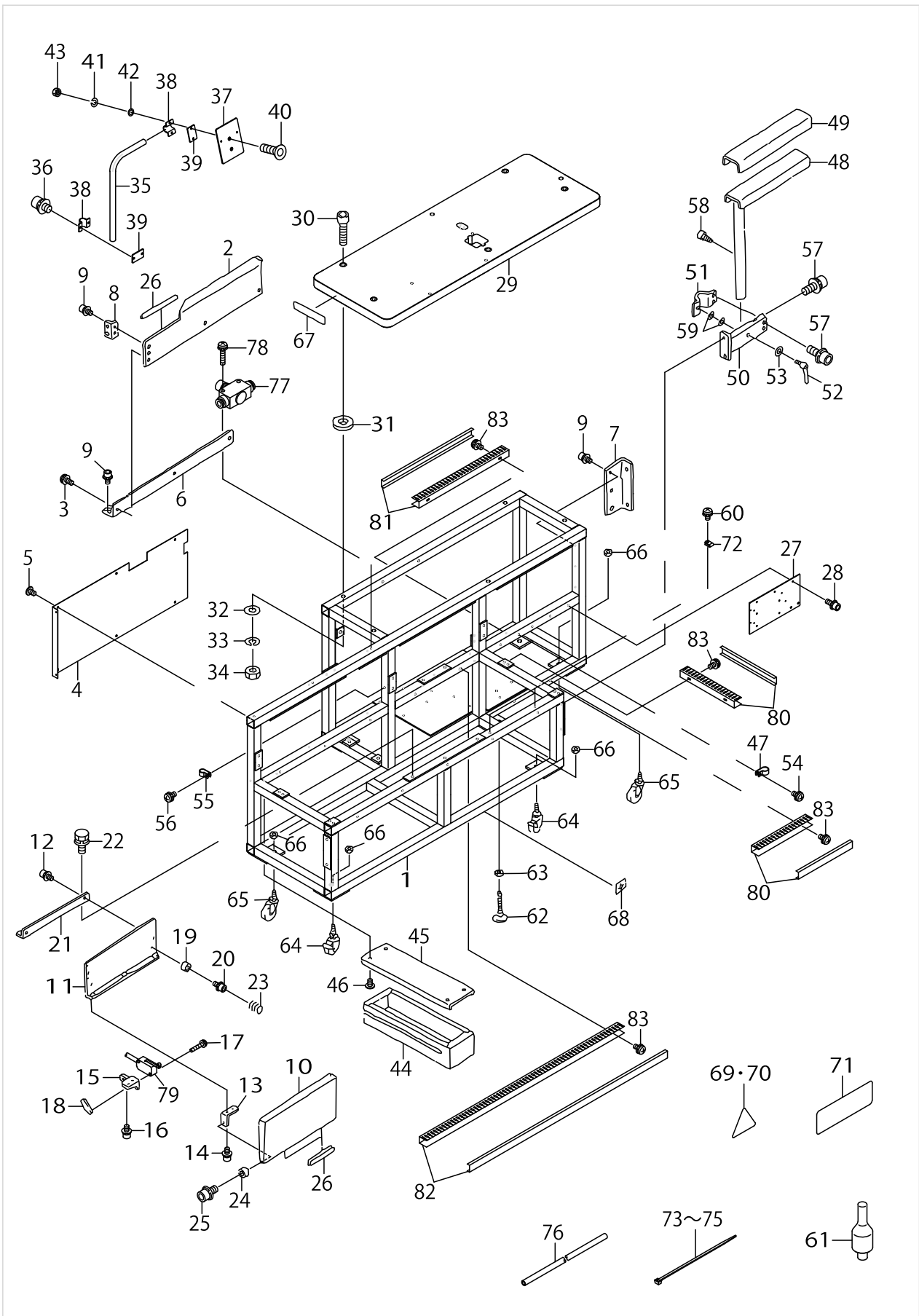

FRAME & MECHANISM COVER COMPONENTS (1)

No.	Parts No.	Parts name	Remarks	Level	Cons	Qty
48	G50281720A0	CLOTH LAYING TABLE				1
49	G5029172000	CLOTH LAYING TABLE CUSHION				1
50	G50301720A0	CLOTH LAYING TABLE SUPPORT				1
51	G5031172000	CLOTH LAYING TABLE SADDLE				1
52	G5032172000	CLOTH LAYING TABLE LEVER				1
53	WP0841601SC	WASHER 8.4X17.4X1.6				1
54	SL4040881SC	SCREW M4 L=8				3
55	HX00150000D	CABLE CLIP				1
56	SL4040881SC	SCREW M4 L=8				1
57	SL6061692TN	BOLT				4
58	SM6061202TN	BOLT				1
59	MTJMGC00000	RUBBER CUSHION				2
60	SL4040881SC	SCREW M4 L=8				3
61	14101208	HEAD SUPPORT BAR				1
62	G5033172000	ADJUSTER				1
63	NM6160001SC	NUT				1
64	G5031164000	CASTER WITH BRAKE				4
65	G5032164000	CASTER				2
66	NM6160001SC	NUT				6
67	40015134	COMOLETE_NAME_PLATE				1
68	16870206	GRAVITY SEAL				1
69	CM300200003	ATTENTION LABEL				3
70	CM300200004	LABEL (50)				1
71	CM301300001	SAFETY LABEL				1
72	HX001500000	CLIP				3
73	EA9500B0100	CABLE BAND				7
74	HX00065000B	CABLE BAND				4
75	HX002920000	BAND				3
76	BT0400251EB	URETHANE HOSE, BLACK				1
77	PC012601000	SPEED CONTROLLER				1
78	SL4042081SC	SCREW				1
79	40016844	START SWITCH ASSY				1
80	G6801172000	DUCT, A				2
81	G6802172000	DUCT, B				1
82	G6803172000	DUCT, C				1
83	SL4040891SC	SCREW M4 L=8				12

FRAME & MECHANISM COVER COMPONENTS (2)

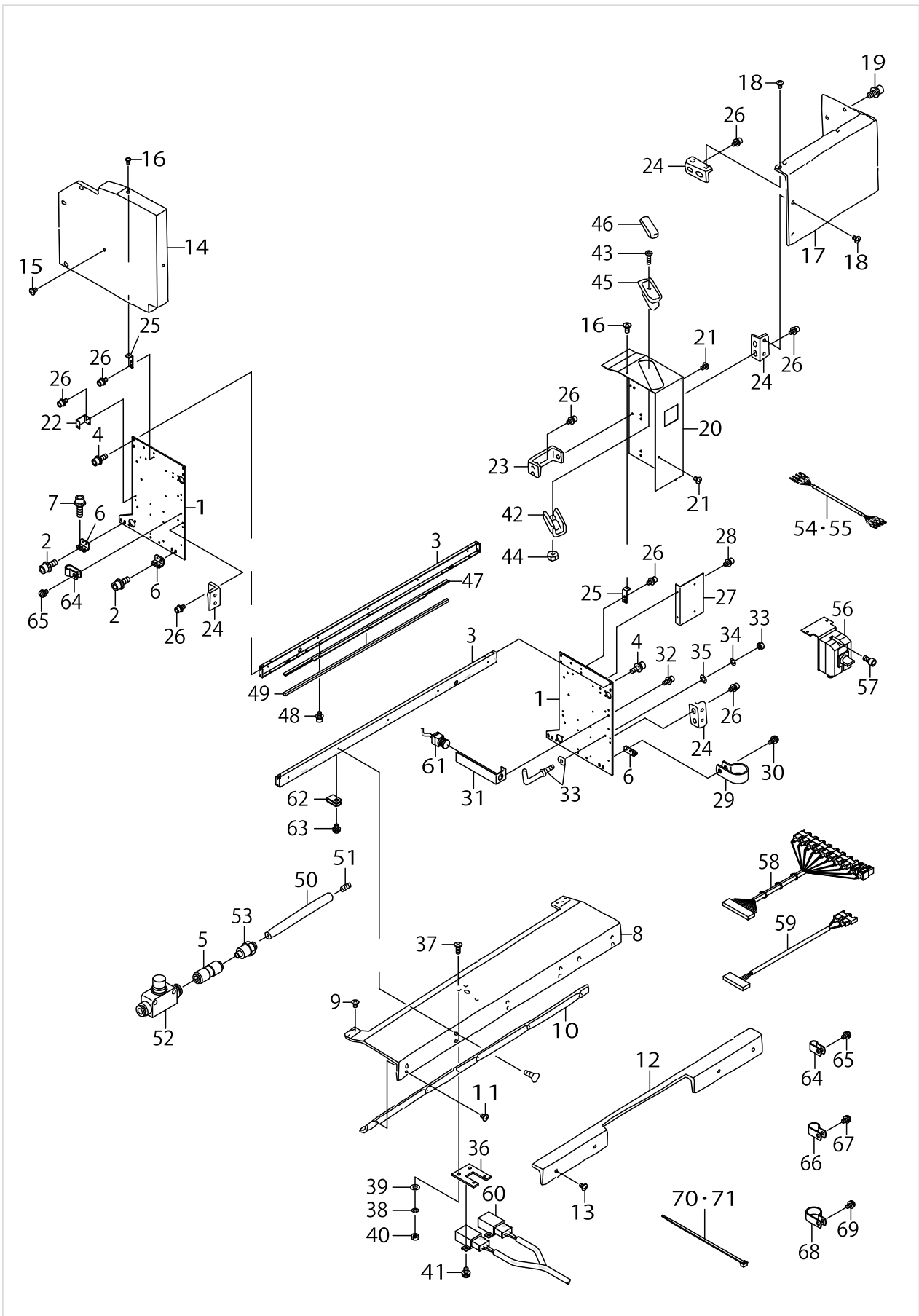

FRAME & MECHANISM COVER COMPONENTS (2)

No.	Parts No.	Parts name	Remarks	Level	Cons	Qty
1	40015611	SIDE_COVER				2
2	SL6061692TN	BOLT				8
3	G5003172000	SIDE PLATE CONNECTING PLATE				2
4	SL6051492TN	BOLT				8
5	PJ303060001	STRAIGHT UNION				1
6	G5037172000	SIDE PLATE				4
7	SL6062092TN	SCREW M6 L=20				8
8	G5014172000	UPPER COVER				1
9	SM0040601SA	SCREW				9
10	G5015172000	FRONT COVER, TOP				1
11	SM0040601SA	SCREW				5
12	G5016172000	FRONT COVER, BOTTOM				1
13	SM0040601SA	SCREW				4
14	G5017172000	LEFT COVER				1
15	SM0040601SA	SCREW				5
16	SM0030601SA	SCREW M3X0.5 L=6				2
17	G5018172000	RIGHT COVER, LARGE				1
18	SM0040601SA	SCREW				3
19	SL6061492TN	BOLT				2
20	40019864	RIGHT_COVER				1
21	SM0040601SA	SCREW				2
22	G5023172000	LEFT COVER SUPPORT				1
23	G5025172000	RIGHT COVER SUPPORT, SMALL				1
24	G5034171000	COVER SUPPORT				5
25	G5016162000	STOPPER PLATE				2
26	SL6040892TN	BOLT				18
27	40015612	SWITCH_BASE				1
28	SL6040892TN	BOLT				2
29	HX00150000K	CABLE CLIP				2
30	SL4041081SC	SCREW M4 L=10				2
31	G5026172000	EMERGENCY SWITCH FITTING PLATE				1
32	SL6041092TN	SCREW				2
33	G5026162000	HOOK				1
34	WS0510002KN	SPRING WASHER				1
35	WP0531001SC	WASHER				1
36	G5013172000	CLOTH SENSOR FITTING PLATE				2
37	SM1030801SC	SCREW M3 L=8				4
38	WS0310002KN	SPRING WASHER M3				4
39	WP0320501SC	WASHER M3				4
40	NM6030001SC	NUT M3				4
41	SL4030681SC	SCREW M3 L=6				4
42	G5027172000	SMALL CASTINGS CASE SUPPOT				1
43	SM4041401SC	SCREW M4X0.7 L=14				2
44	NM6040001SC	NUT M4				2
45	11156007	CASE				1
46	11155801	CASE MAGNET				1
47	G5217172000	CLOTH PRESSER PLATE				1



FRAME & MECHANISM COVER COMPONENTS (2)

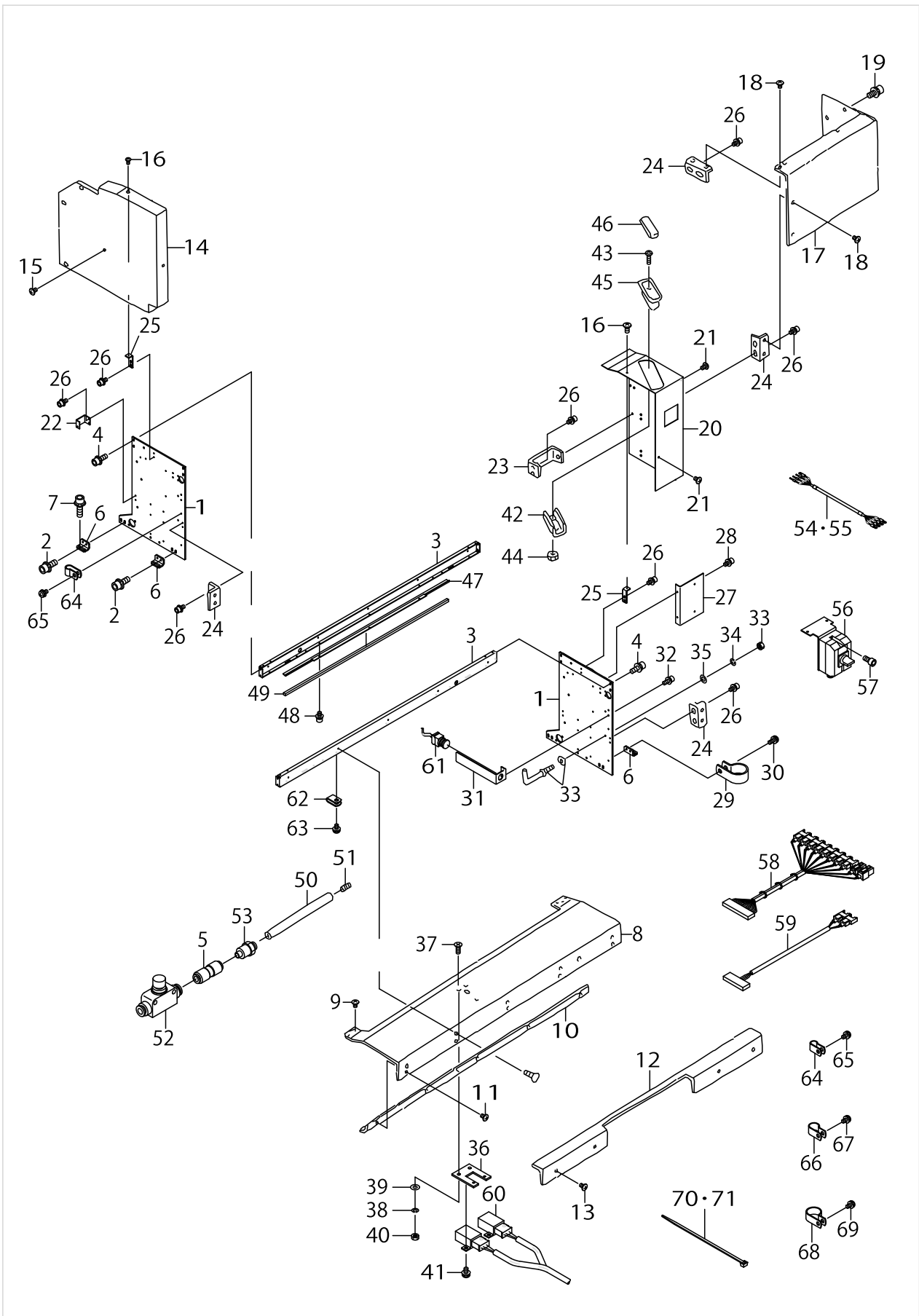

FRAME & MECHANISM COVER COMPONENTS (2)

No.	Parts No.	Parts name	Remarks	Level	Cons	Qty
48	SL6040892TN	BOLT				3
49	G5212172000	PUSHER CUSHION				1
50	G5136172000	BLOW PIPE				1
51	SM8050812TP	SCREW M5X8				1
52	PC012601000	SPEED CONTROLLER				1
53	PJ032059008	NIPPLE				1
54	40017091	AC POWER CORD 3P ASSY				1
55	40017092	AC POWER CORD 1P ASSY				1
56	HA004860000	POWER SWITCH				1
57	SM6051002TN	BOLT				2
58	40016852	SENSOR JOINT CORD A ASSY				1
59	40016853	SENSOR JOINT CORD B ASSY				1
60	40016845	CLOTH DETECT SENSOR ASSY				1
61	40015562	PAUSE SWITCH ASSY				1
62	HX001500000	CLIP				1
63	SL4040881SC	SCREW M4 L=8				1
64	HX00150000B	CABLE CLIP				1
65	SL4040881SC	SCREW M4 L=8				1
66	HX00150000D	CABLE CLIP				1
67	SL4040881SC	SCREW M4 L=8				1
68	HX00150000H	CABLE CLIP				4
69	SL4040881SC	SCREW M4 L=8				4
70	EA9500B0100	CABLE BAND				12
71	HX00065000B	CABLE BAND				3

FEED BODY COMPONENTS (1)

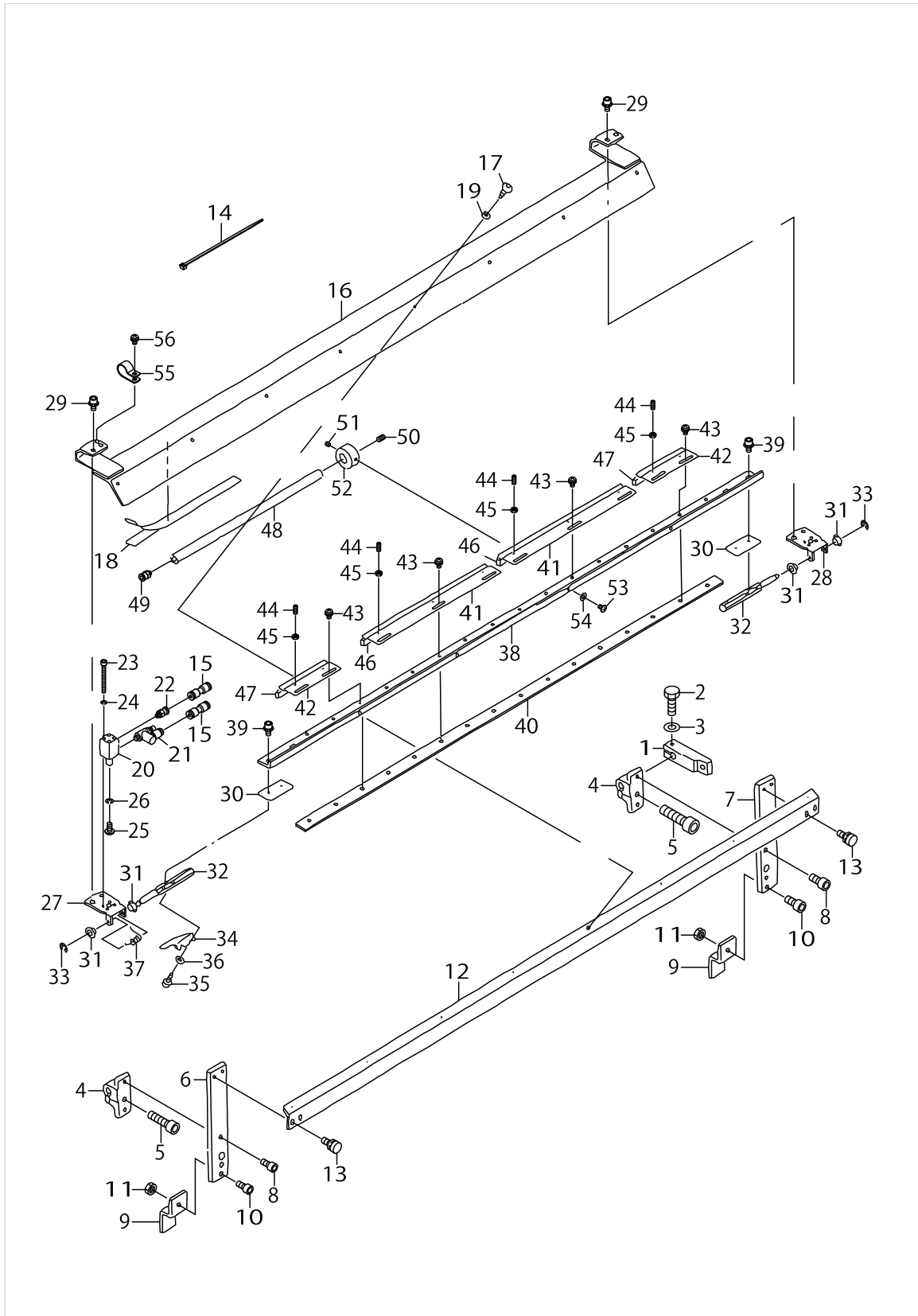

FEED BODY COMPONENTS (1)

No.	Parts No.	Parts name	Remarks	Level	Cons	Qty
1	G5115172000	ROCKING ARM				1
2	SM9082503SE	HEXAGONAL HEADED BOLT				1
3	WP0841601SC	WASHER 8.4X17.4X1.6				1
4	G5116172000	STUD BRACKET				2
5	SM6083002TP	SCREW M8 L=30				2
6	G5117172000	STUD, LEFT				1
7	G5118172000	STUD, RIGHT				1
8	SM6061202TP	SCREW M6 L=12				4
9	G5119172000	STUD STOPPER				2
10	SM6061202TP	SCREW M6 L=12				2
11	NM6060003SC	NUT M6				2
12	G5122172000	CLAMP TABLE SUPPORT				1
13	SL9061693SE	WASHER HEXAGONAL BOLT M6 L=16				4
14	EA9500B0100	CABLE BAND				8
15	PJ303040002	STRAIGHT UNION				2
16	G51231720A0	CLAMP TABLE				1
17	G5144162000	SCREW				8
18	G5138172000	CLAMP TABLE LINER				1
19	WS0410002KN	SPRING WASHER				8
20	PA160100500	AIR CYLINDER				1
21	PC010519000	SPEED CONTROLLER				1
22	PJ301040502	HALF UNION 4XM5				1
23	SM6033052TP	SCREW				4
24	WS0310002KN	SPRING WASHER M3				4
25	SM4040801SN	SCREW M4 L=8				1
26	WS0410002KN	SPRING WASHER				1
27	G5124172000	HOLDING PLATE, LEFT				1
28	G5125172000	HOLDING PLATE, RIGHT				1
29	SL6051092TN	BOLT				4
30	G5140172000	SPACER				2
31	G5126172000	CLAMP SHAFT HOLDER				4
32	G5127172000	CLAMP SHAFT				2
33	RE0500000K0	E-RING				2
34	G5128172000	CLAMP SHAFT ARM				1
35	G5144162000	SCREW				2
36	WP0430801SC	WASHER 4.3X9X0.8				2
37	G5129172000	CLAMP SPRING				1
38	G5130172000	CLAMP FITTING BASE				1
39	SL6051092TN	BOLT				4
40	G5131172000	CLAMP FITTING NUT				1
41	G5132172000	CLAMP, LARGE				2
42	G5133172000	CLAMP, SMALL				2
43	SL4040891SC	SCREW M4 L=8				12
44	SM8041012TP	SCREW M4 L=10				10
45	NM6040003SC	NUT M4				10
46	G5134172000	CLAMP CUSHION, LARGE				2
47	G5135172000	CLAMP CUSHION, SMALL				1

FEED BODY COMPONENTS (1)

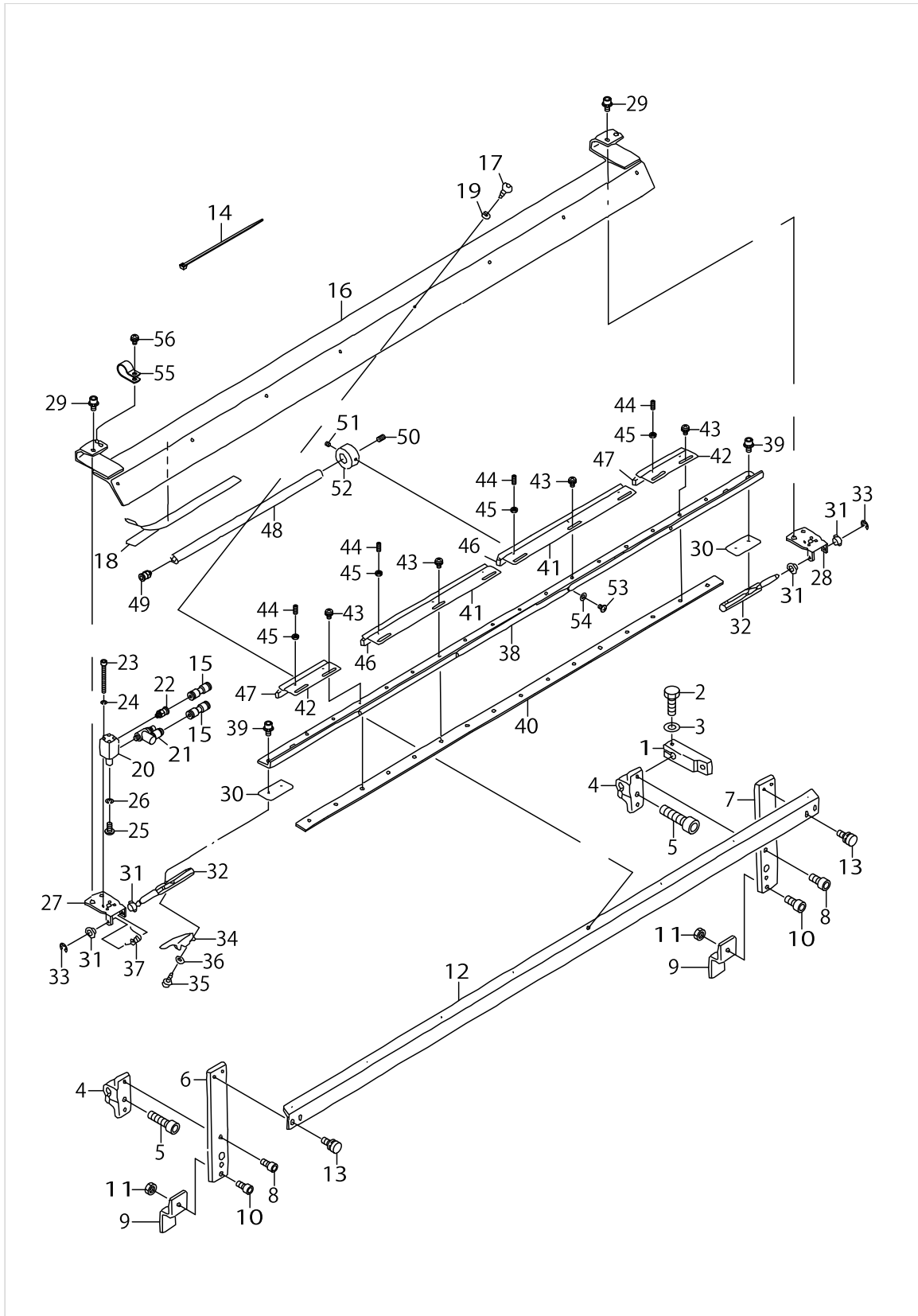

FEED BODY COMPONENTS (1)

No.	Parts No.	Parts name	Remarks	Level	Cons	Qty
48	G5136172000	BLOW PIPE				1
49	PJ301060503	HALF UNION				1
50	SM8050812TP	SCREW M5X8				1
51	SM8040402TP	SCREW M4X0.7 L=4				4
52	G5137172000	BLOW PIPE HOLDER				4
53	SM0040601SA	SCREW				4
54	WP0430801SC	WASHER 4.3X9X0.8				4
55	HX00150000F	CABLE CLIP				2
56	SL4040881SC	SCREW M4 L=8				2

FEED BODY COMPONENTS (2)

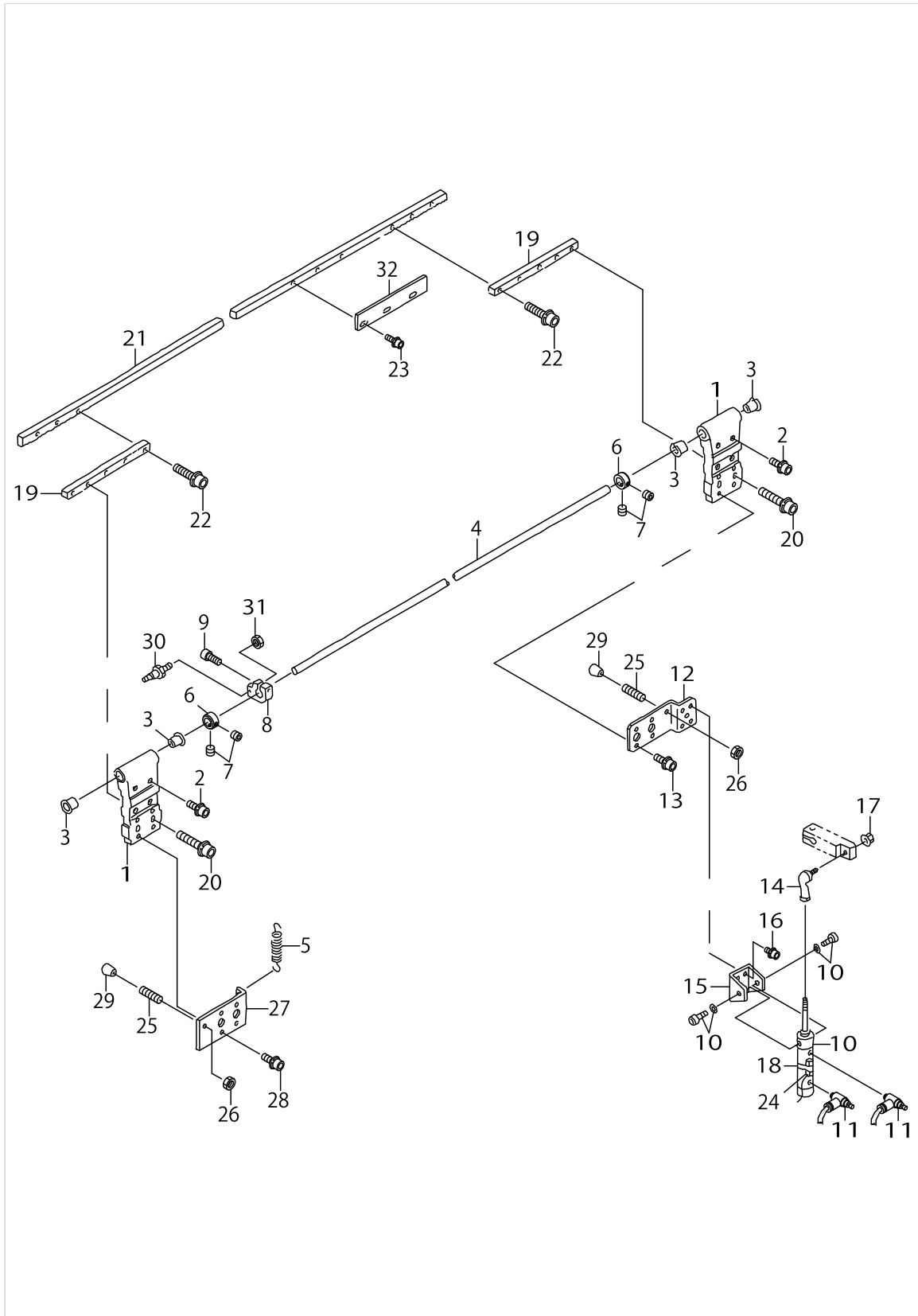

FEED BODY COMPONENTS (2)

No.	Parts No.	Parts name	Remarks	Level	Cons	Qty
1	G5101172000	FEED BODY				2
2	SL6051442TN	BOLT				8
3	G5112172000	FEED BODY FALLING SHAFT HOLDER				4
4	G5113172000	FEED BODY FALLING SHAFT				1
5	40020109	CLAMP_TABLE_SPRING				1
6	16136905	THRUST COVER				2
7	SS8660612TP	SCREW 1/4-40 L=6				4
8	11206505	FEED DRIVING LINK				1
9	SS6121212TP	SCREW 3/16-28 L=12.0				1
10	PA200251500	AIR CYLINDER (DIA20-25ST)				1
11	PC010508000	SPEED CONTROLLER				2
12	G5114172000	FALLING CYLINDER SUPPORT				1
13	SL6051492TN	BOLT				4
14	G5204171000	LINK BOLL				1
15	PA900041000	CYLINDER BRACKET				1
16	SL6040892TN	BOLT				4
17	G5238171000	NUT				1
18	PX906003000	SWITCH CLAMP (DIA20)				1
19	G5106172000	RACK FIXING ROD				2
20	SL6063092TN	SCREW M6 L=30				4
21	G5107172000	RACK				1
22	SL6062592TN	SCREW				6
23	SL6041292TN	SCREW				3
24	40016849	CARRIER MOV CYL SW ASSY				1
25	SM8062012TP	SCREW M6 L=20				2
26	NM6060003SC	NUT M6				2
27	G5120172000	STUD STOPPER FITTING PLATE				1
28	SL6051492TN	BOLT				4
29	G5138161000	RUBBER CAP				2
30	G5121172000	SPRING HOOK				1
31	NM6060003SC	NUT M6				1
32	G5102164000	ORIGINAL POINT SENSOR PLATE				1



FEED BODY COMPONENTS (3)

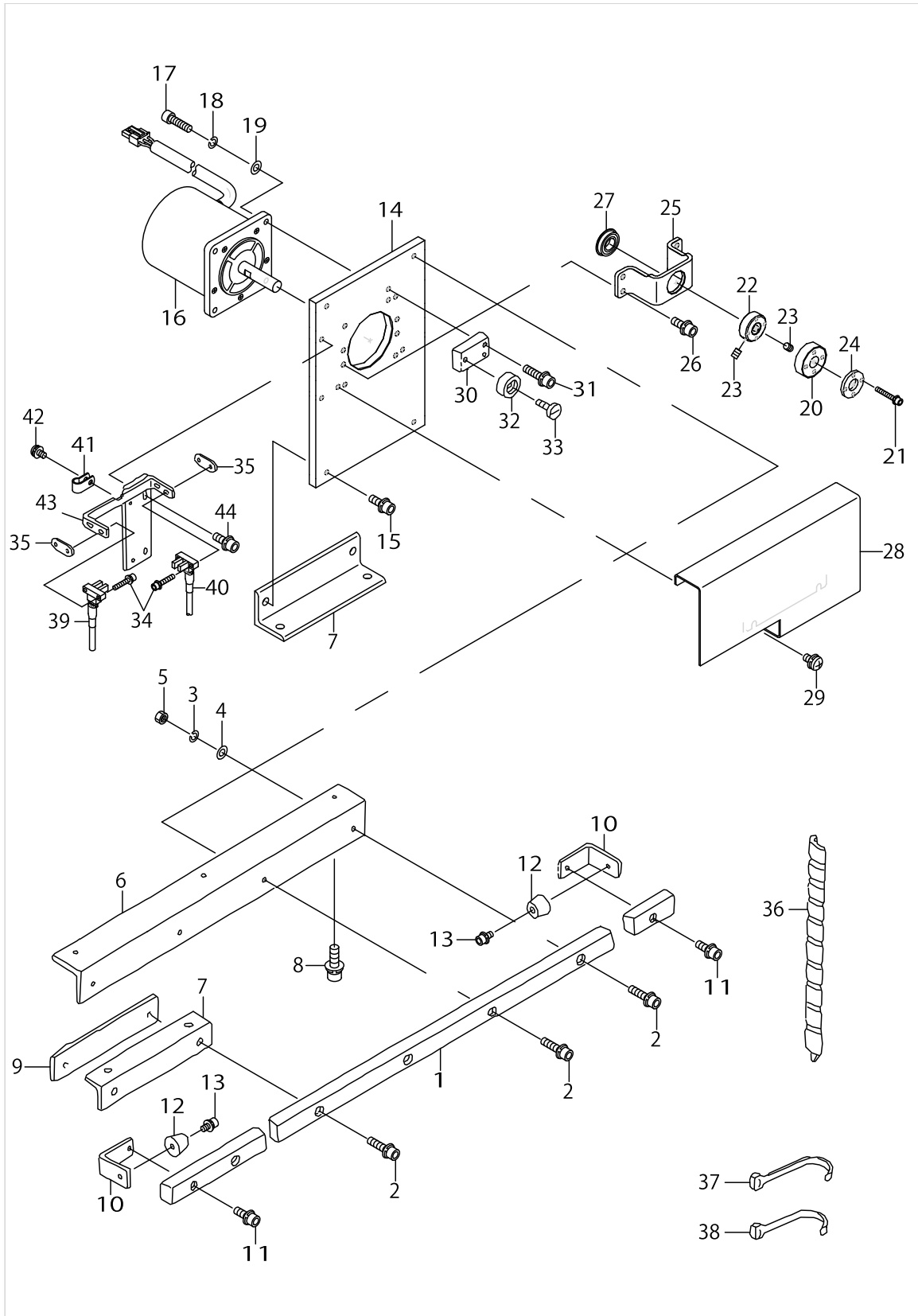

FEED BODY COMPONENTS (3)

No.	Parts No.	Parts name	Remarks	Level	Cons	Qty
1	G5010164000	FEED RAIL				1
2	SL6052042TN	SCREW				14
3	WS0510002KN	SPRING WASHER				2
4	WP0531001SC	WASHER				2
5	NM6050001SC	NUT M5				2
6	G5102172000	FEED RAIL SUPPORT, LARGE				2
7	G5103172000	FEED RAIL SUPPORT, SMALL				3
8	SL6062092TN	SCREW M6 L=20				13
9	G5104172000	RAIL FIXING NUT				5
10	G5105172000	FITTING PLATE				2
11	SL6051442TN	BOLT				2
12	G5009172000	STOPPER RUBBER				2
13	SL6040842TN	SCREW M4 L=8				2
14	40012545	MOTOR_BASE_PLATE				1
15	SL6051492TN	BOLT				2
16	40016666	CARRIER MOTOR				1
17	SM6051802TP	SCREW M5 L=18				4
18	WS0510002KN	SPRING WASHER				4
19	WP0531001SC	WASHER				4
20	40012547	GEAR				1
21	SL6032092TN	BOLT				4
22	40012546	GEAR_BOSS				1
23	SM8060802TP	SCREW M6 L=8				2
24	40012548	GEAR_PLATE				1
25	40012529	BEARING_BASE				1
26	SL6051492TN	BOLT				4
27	SB112001100	BEARING				1
28	G5139172000	FEED MECHANISM COVER				1
29	SL4051091SC	SCREW M5X0.8 L=10				2
30	G5110172000	RACK HOLDER FITTING PLATE				1
31	SL6052092TN	SCREW				2
32	G5111172000	RACK HOLDER				1
33	G5150162000	SCREW				1
34	SL6031642TN	SCREW				4
35	G5153171000	SENSOR PLATE				2
36	G5454161000	SPIRAL TUBE				2
37	EA9500B0100	CABLE BAND				6
38	EA9500B0200	CABLE BAND 150				1
39	40016842	CARRIER ORG SENSOR ASSY				1
40	40016843	CARRIER DECEL SENSOR ASSY				1
41	HX00150000B	CABLE CLIP				2
42	SL4040881SC	SCREW M4 L=8				2
43	G5108172000	FITTING PLATE				1
44	SL6051492TN	BOLT				2

STACKER COMPONENTS (1)

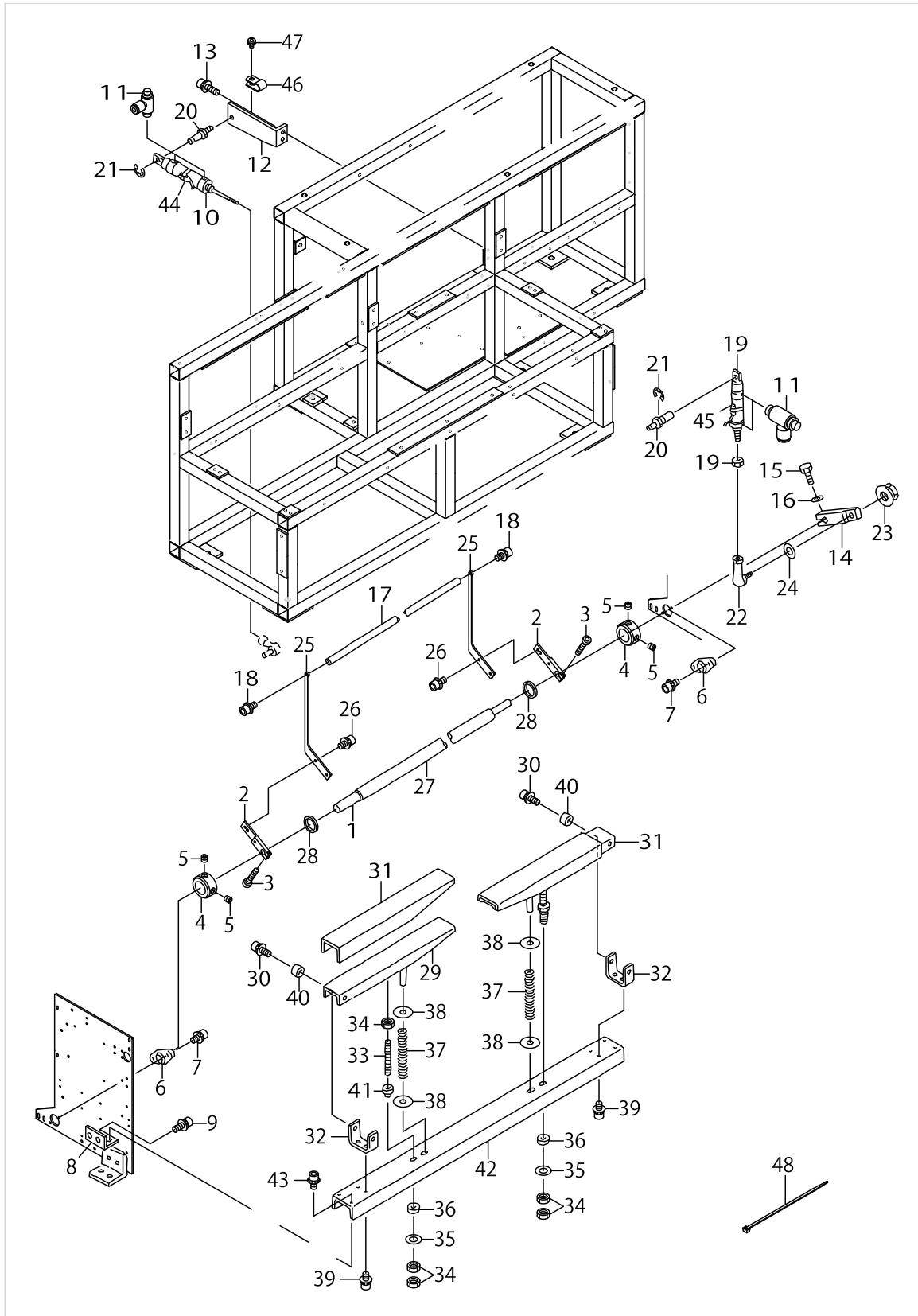

STACKER COMPONENTS (1)

No.	Parts No.	Parts name	Remarks	Level	Cons	Qty
1	G5213172000	PUSHER ROCKING SHAFT				1
2	40016101	STACKER_SHAFT_ARM				2
3	SM6062502TP	SCREW M6 L=25				2
4	16136905	THRUST COVER				2
5	SS8660612TP	SCREW 1/4-40 L=6				4
6	G5239171000	FLANGE				2
7	SL6061292TN	SCREW				4
8	G5214172000	ROCKING HOLDER SHAFT BASE				2
9	SL6061692TN	BOLT				4
10	PA2007508A0	AIR CYLINDER				1
11	PC015108000	SPEED CONTROLLER				4
12	G52151720A0	PUSHER ROCKING CYLINDER BASE				1
13	SL6062092TN	SCREW M6 L=20				2
14	G5115172000	ROCKING ARM				1
15	SM9082503SE	HEXAGONAL HEADED BOLT				1
16	WP0841601SC	WASHER 8.4X17.4X1.6				1
17	G5218172000	SWING BAR				1
18	SL6061292TN	SCREW				2
19	PA2005015A0	AIR CYLINDER				1
20	G5216172000	ROCKING FULCRUM SHAFT				2
21	RE0700000K0	E-RING 7				2
22	G5204171000	LINK BOLL				1
23	G5238171000	NUT				1
24	WP0841601SC	WASHER 8.4X17.4X1.6				1
25	G5219172000	SWING BAR ARM				2
26	SL6061292TN	SCREW				4
27	G5220172000	SWING BAR SHAFT SPACER				1
28	HX00055000C	CABLE CLIP				2
29	G52211720A0	CLOTH PILING TABLE				2
30	SL6061692TN	BOLT				4
31	G5222172000	CUSHION				2
32	G5223172000	CLOTH PILING TABLE SUPPORT				2
33	G5224172000	CLOTH PILING SUPPORT BOLT				2
34	NM6080003SC	NUT M8				6
35	WP0841601SC	WASHER 8.4X17.4X1.6				2
36	MTJMGC00000	RUBBER CUSHION				2
37	B1505040000	PRESSER SPRING				2
38	WP0651646SC	WASHER				4
39	SL6061292TN	SCREW				4
40	B1504761A00	ROLLER COLLAR (A)				4
41	G5225172000	CLOTH PILING TABLE ROCK NUT				2
42	G5226172000	CLOTH PILING TABLE HOLDER				1
43	SL6061292TN	SCREW				4
44	40016850	STACKER CNT CYL SW ASSY				1
45	40016851	STACKER2 CYL SW ASSY				1
46	HX00150000B	CABLE CLIP				1
47	SL4040881SC	SCREW M4 L=8				1

STACKER COMPONENTS (1)

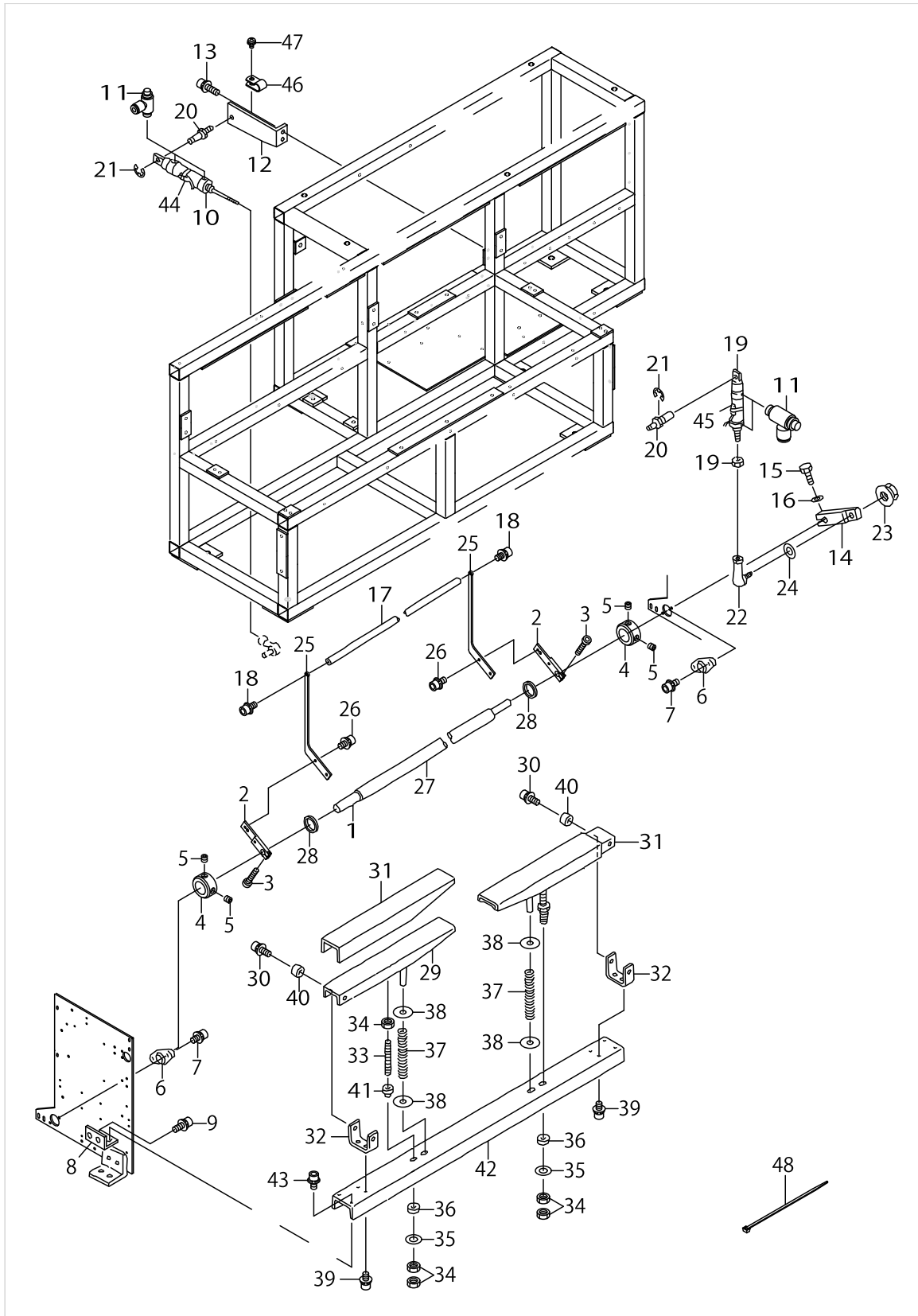

STACKER COMPONENTS (1)

No.	Parts No.	Parts name	Remarks	Level	Cons	Qty
48	HX00065000B	CABLE BAND				1

STACKER COMPONENTS (2)

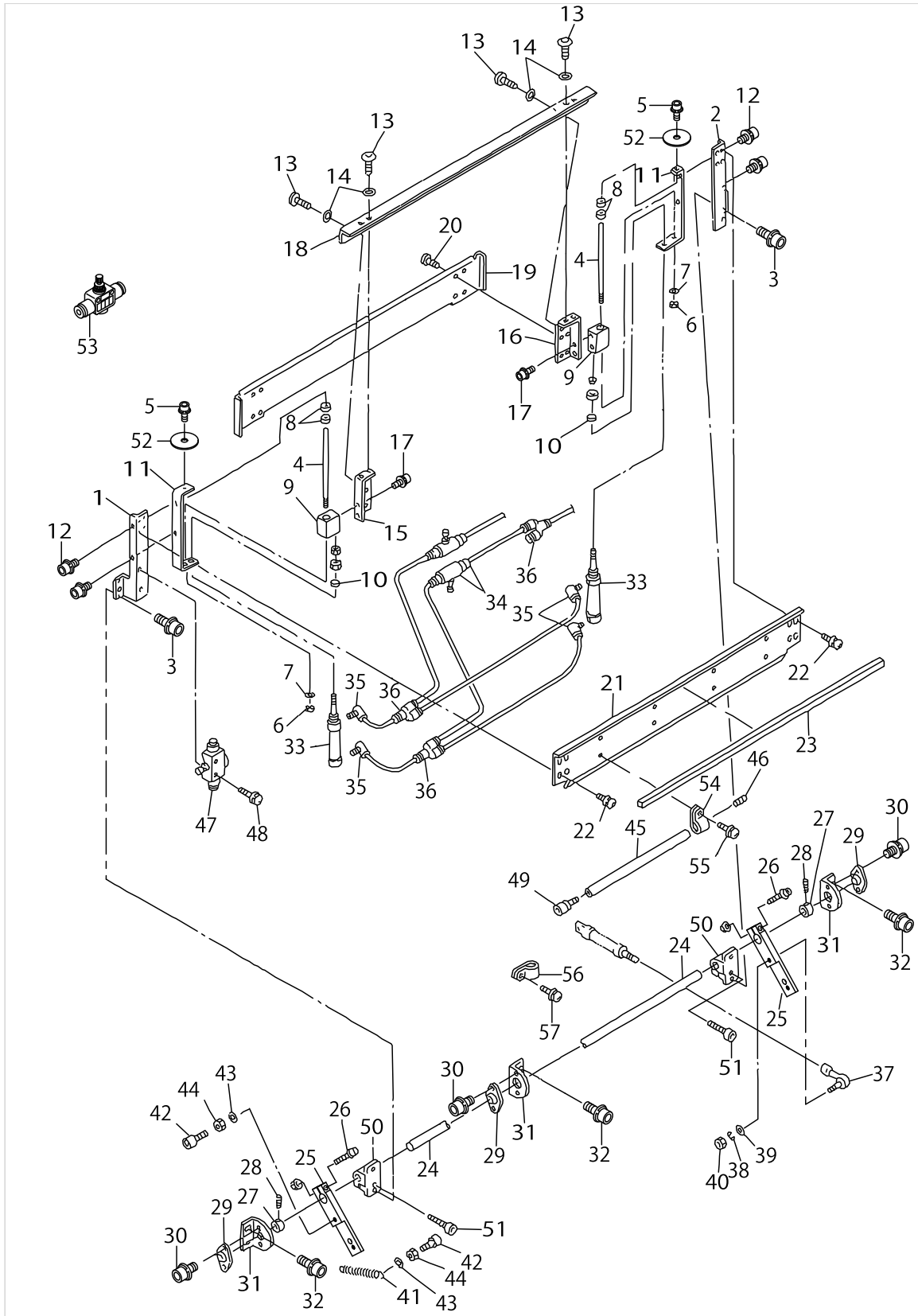

STACKER COMPONENTS (2)

No.	Parts No.	Parts name	Remarks	Level	Cons	Qty
1	G5201172000	PUSHER STUD, LEFT				1
2	G5202172000	PUSHER STUD, RIGHT				1
3	SL6061692TN	BOLT				4
4	G5204172000A	PUSHER SHAFT				2
5	SL6041042TN	BOLT				2
6	NM6080001SC	NUT M8X1.25				4
7	WP0841601SC	WASHER 8.4X17.4X1.6				4
8	SB708000100	BEARING				4
9	G5205172000	PUSHER SHAFT HOLDING BOX				2
10	PA900024000	FLOATING JOINT A				2
11	G5203172000A	PUSHER SHAFT BASE				2
12	SL6051092TN	BOLT				4
13	G5144162000	SCREW				8
14	WP0430801SC	WASHER 4.3X9X0.8				8
15	G5207172000	PUSHER PLATE, LEFT				1
16	G5208172000	PUSHER PLATE, RIGHT				1
17	SL6041092TN	SCREW				4
18	G5209172000	PUSHER				1
19	G5210172000	PUSHER COVER				1
20	SM0040601SA	SCREW				8
21	G5211172000	PUSHER STAY				1
22	SL4040691SC	SCREW M4 L=6				8
23	G5212172000	PUSHER CUSHION				1
24	G5213172000	PUSHER ROCKING SHAFT				1
25	40016101	STACKER_SHAFT_ARM				2
26	SM6052502TP	SCREW M5X0.8 L=25				2
27	16136905	THRUST COVER				2
28	SS8660612TP	SCREW 1/4-40 L=6				4
29	G5239171000	FLANGE				3
30	SL6061292TN	SCREW				6
31	G5214172000	ROCKING HOLDER SHAFT BASE				3
32	SL6061692TN	BOLT				6
33	PA1008501A0	AIR CYLINDER (DIA10-85ST)				2
34	PC012401000	SPEED CONTROLLER				2
35	PJ304040504	ELBOW UNION				4
36	PJ308040002	QUICK COUPLING				3
37	G5204171000	LINK BOLL				1
38	WS0820002KN	SPRING WASHER M8				1
39	WP0841601SC	WASHER 8.4X17.4X1.6				1
40	NM6080001SC	NUT M8X1.25				1
41	G5227172000	SPRING				1
42	SM6063002TN	SCREW M6 L=30				2
43	WP0641601SC	WASHER				2
44	NM6060001SC	NUT M6				2
45	G5136172000	BLOW PIPE				1
46	SM8050812TP	SCREW M5X8				1
47	PC012601000	SPEED CONTROLLER				1



STACKER COMPONENTS (2)

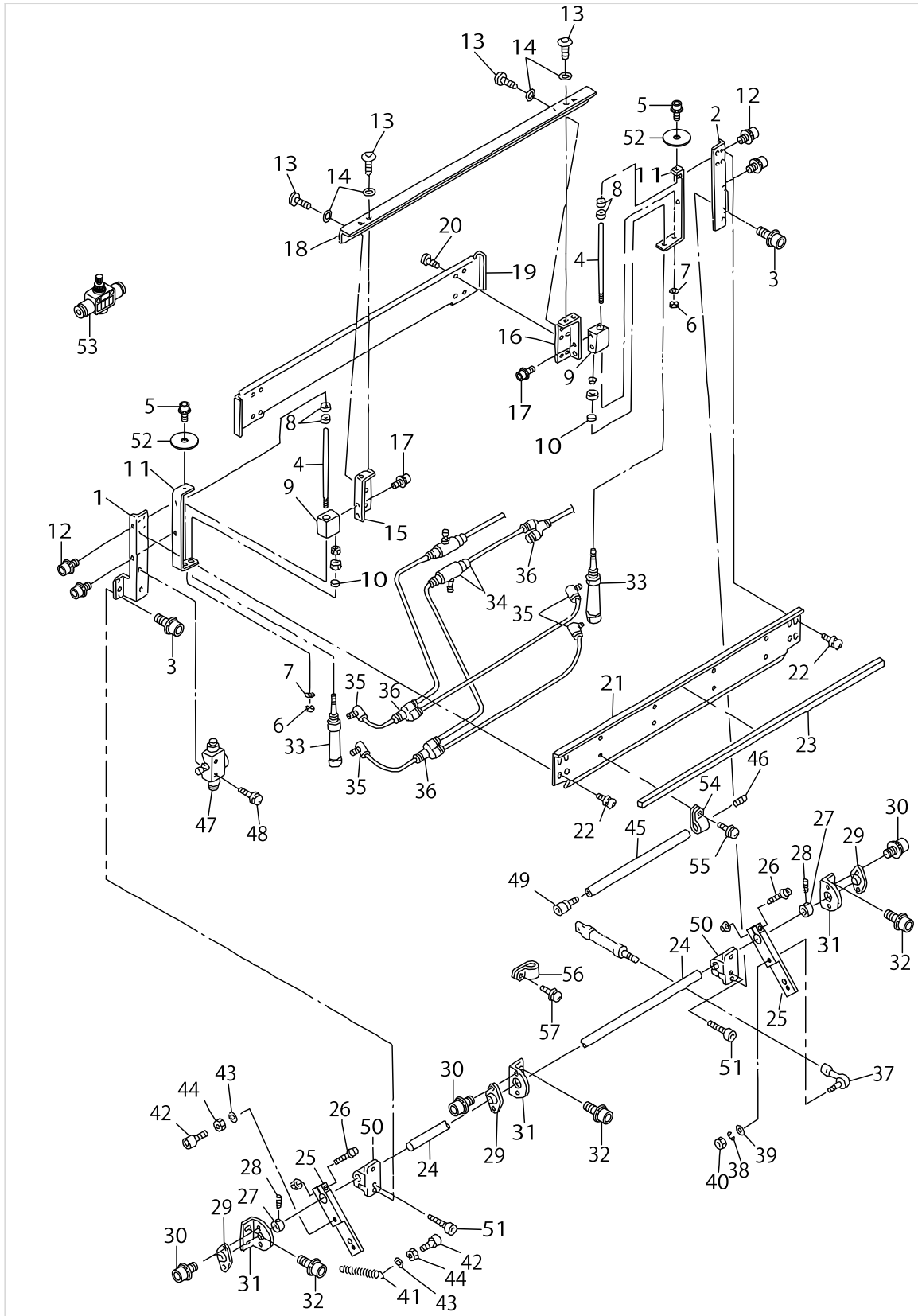

STACKER COMPONENTS (2)

No.	Parts No.	Parts name	Remarks	Level	Cons	Qty
48	SL4042091SC	SCREW M4X0.7 L=20				1
49	PJ032059008	NIPPLE				1
50	G5116172000	STUD BRACKET				2
51	SM6083002TN	SCREW M8 L=30				2
52	WP0451016SP	WASHER 4.5X20X1				2
53	PC012401000	SPEED CONTROLLER				1
54	HX00150000B	CABLE CLIP				5
55	SL4040881SC	SCREW M4 L=8				5
56	HX00150000C	CABLE CLIP				1
57	SL4040881SC	SCREW M4 L=8				1

PRESET COMPONENTS (1)

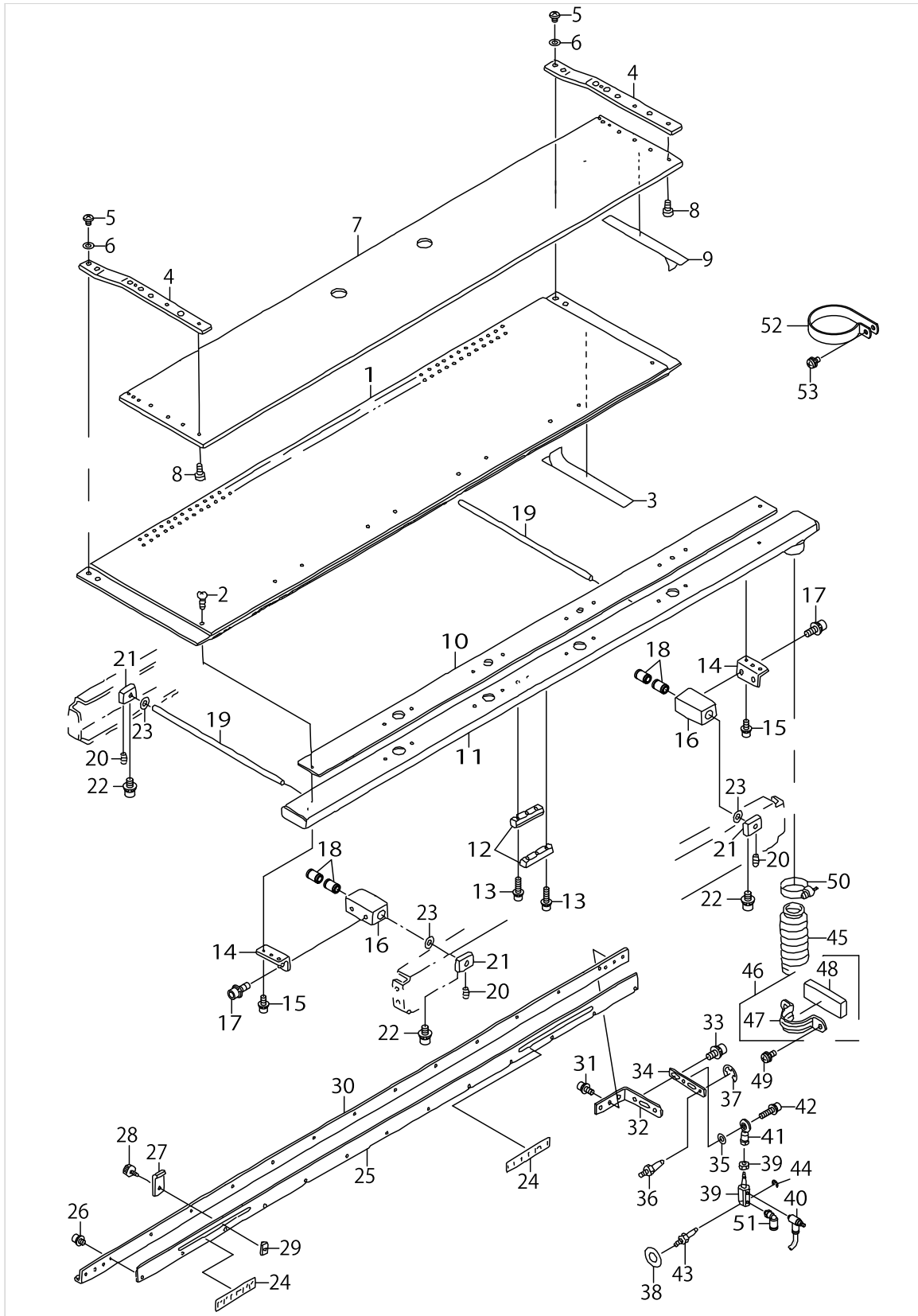

PRESET COMPONENTS (1)

No.	Parts No.	Parts name	Remarks	Level	Cons	Qty
1	G5809172000	PRESET TABLE				1
2	SM0041001SC	SCREW M4 L=10				10
3	G5302172000	PRESET TABLE LINER				5
4	G5303172000	AUXILIARY PRESET PLATE SUPPORT				2
5	SM4040801SN	SCREW M4 L=8				4
6	WP0430801SC	WASHER 4.3X9X0.8				4
7	G5304172000	AUXILIARY PRESET PLATE				1
8	SM6020350SP	SCREW M2 L=2.5				6
9	G5305172000	AUXILIARY PRESET LINER				5
10	G5306172000	PRESET PACKING				1
11	G53071720A0	PRESET FITTING PLATE				1
12	G5308172000	CAM FOLLOWER RAIL				2
13	SL6041642TN	SCREW				6
14	G5309172000	SHAFT HOLDING BOX SUPPORT				2
15	SL6041092TN	SCREW				6
16	G5310172000	SLIDE SHAFT HOLDING BOX				2
17	SL6051492TN	BOLT				4
18	SB710000200	SLIDE BEARING				4
19	G5311172000	SLIDE SHAFT				2
20	SM8050602TP	SCREW M5 L=6				4
21	G5312172000	SLIDE SHAFT SUPPORT				4
22	SL6051092TN	BOLT				8
23	G5313172000	SLIDE SHAFT RUBBER				4
24	G5352171000A	SCALE, RIGHT				2
25	G5334172000	SET PLATE				1
26	SL6040642TN	BOLT				10
27	G5808172000	GAUGE				2
28	G6010003000	KNOB SCREW				2
29	G5810172000	GAUGE NUT				2
30	G5335172000	SET PLATE SUPPORT				1
31	SL6041092TN	SCREW				2
32	G5336172000	SET PLATE SUPPORT ARM				1
33	SL6051292TN	BOLT				2
34	G5337172000	SET PLATE FULCRUM ARM				1
35	WP0430800SC	WASHER M4				1
36	G5216172000	ROCKING FULCRUM SHAFT				1
37	RE0700000K0	E-RING 7				1
38	WP0621016SH	WASHER				1
39	PA1001016A0	AIR CYLINDER (DIA10-10ST)				1
40	PC010508000	SPEED CONTROLLER				1
41	16556300	ROD END				1
42	SL6041642TN	SCREW				1
43	G5338172000	SET PLATE CYLINDER SHAFT				1
44	RE0300000K0	E-RING 3				1
45	G5343172000	VACUUM HOSE, A				1
46	G53461720A0	HOSE HOLDER ASM.				1
47	G5346172000	HOSE HOLDER		*		1

PRESET COMPONENTS (1)

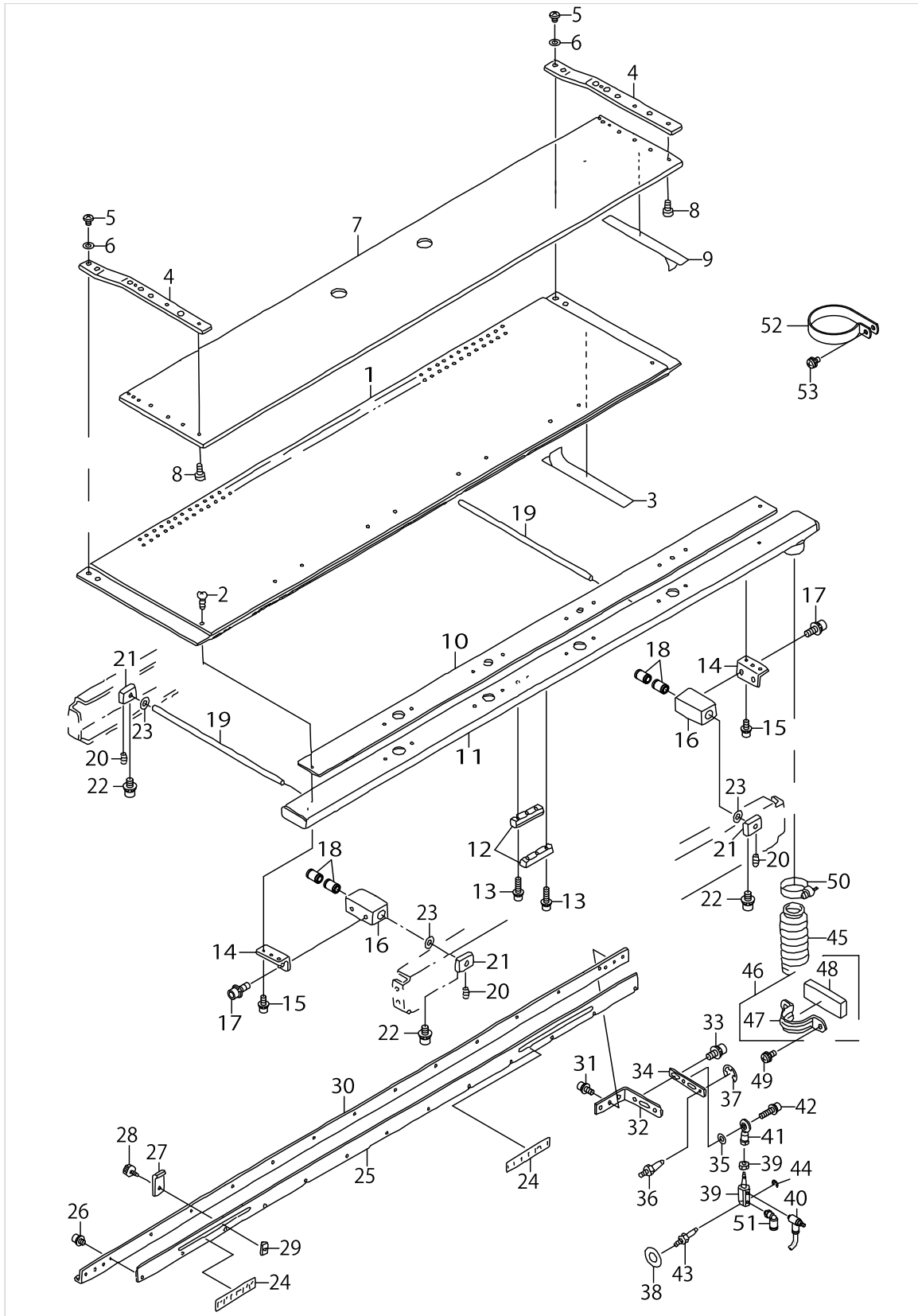

PRESET COMPONENTS (1)

No.	Parts No.	Parts name	Remarks	Level	Cons	Qty
48	G5904172000	HOSE HOLDER RUBBER		*		1
49	SL4041091SC	SCREW M4 L=10				2
50	G5176136000	HOSE BAND				1
51	PJ304040504	ELBOW UNION				1
52	HX00150000S	CABLE BAND				1
53	SL4040881SC	SCREW M4 L=8				1

PRESET COMPONENTS (2)

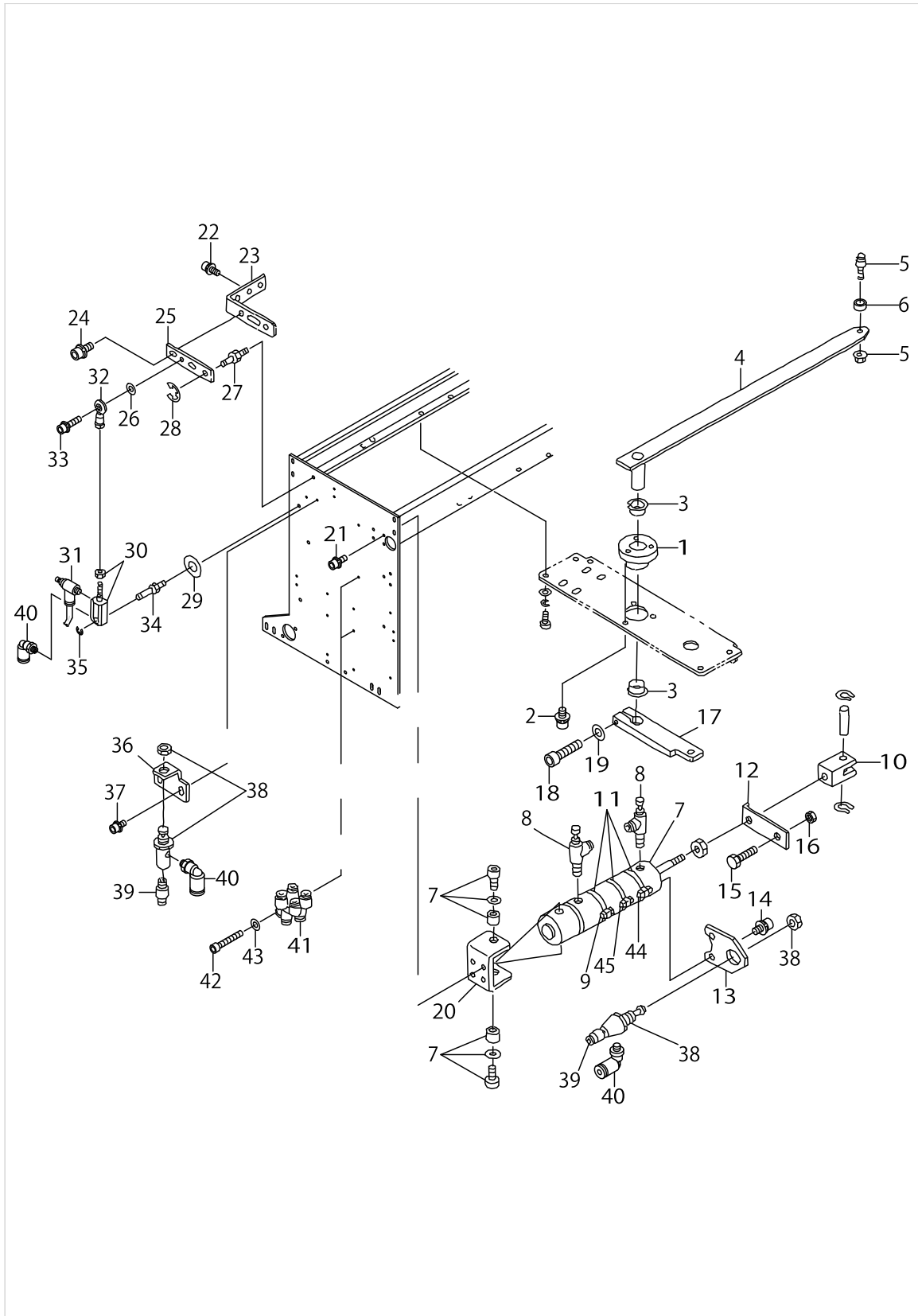

PRESET COMPONENTS (2)

No.	Parts No.	Parts name	Remarks	Level	Cons	Qty
1	G5314172000	PRESET SHAFT HOLDING BOX				1
2	SL6051092TN	BOLT				3
3	G5315172000	PRESET SHAFT HOLDER				2
4	G53161720A0	PRESET DRIVING ARM				1
5	13741806	CHANGE-OVER ROLLER				1
6	11041100	ROLLER				1
7	PA320500200	AIR CYLINDER (DIA32-50ST)				1
8	PC015108000	SPEED CONTROLLER				2
9	40016848	PRESET CYL BKWD SW ASSY				1
10	PA900042000	KNUCKLE JOINT				1
11	PX906004000	SWITCH CLAMP (DIA32)				3
12	G5341172000	RETURN VALVE DOG				1
13	G5342172000	RETURN VALVE FITTING PLATE				1
14	SL6051092TN	BOLT				2
15	SM9052003SC	SCREW M5 L=20				1
16	NM6050003SC	NUT M5X0.8				1
17	G5317172000	PRESET CYLINDER ARM				1
18	SM6062502TP	SCREW M6 L=25				1
19	WP0641601SC	WASHER				1
20	G5318172000	PRESET CYLINDER BASE				1
21	SL6041292TN	SCREW				4
22	SL6041092TN	SCREW				2
23	G5336172000	SET PLATE SUPPORT ARM				1
24	SL6051292TN	BOLT				2
25	G5337172000	SET PLATE FULCRUM ARM				1
26	WP0430800SC	WASHER M4				1
27	G5216172000	ROCKING FULCRUM SHAFT				1
28	RE0700000K0	E-RING 7				1
29	WP0621016SH	WASHER				1
30	PA1001016A0	AIR CYLINDER (DIA10-10ST)				1
31	PC010508000	SPEED CONTROLLER				1
32	16556300	ROD END				1
33	SL6041642TN	SCREW				1
34	G5338172000	SET PLATE CYLINDER SHAFT				1
35	RE0300000K0	E-RING 3				1
36	GMC16007000	START VALVE FITTING PLATE				1
37	SL6040892TN	BOLT				2
38	PV010503000	VALVE				2
39	PJ301040502	HALF UNION 4XM5				2
40	PJ304040504	ELBOW UNION				3
41	PJ308040002	QUICK COUPLING				4
42	SM6042502TP	SCREW M4X0.7 L=25				2
43	WP0430801SC	WASHER 4.3X9X0.8				2
44	40016846	PRESET CYL FWD SW ASSY				1
45	40016847	PRESET CYL MID SW ASSY				1



PRESET COMPONENTS (3)

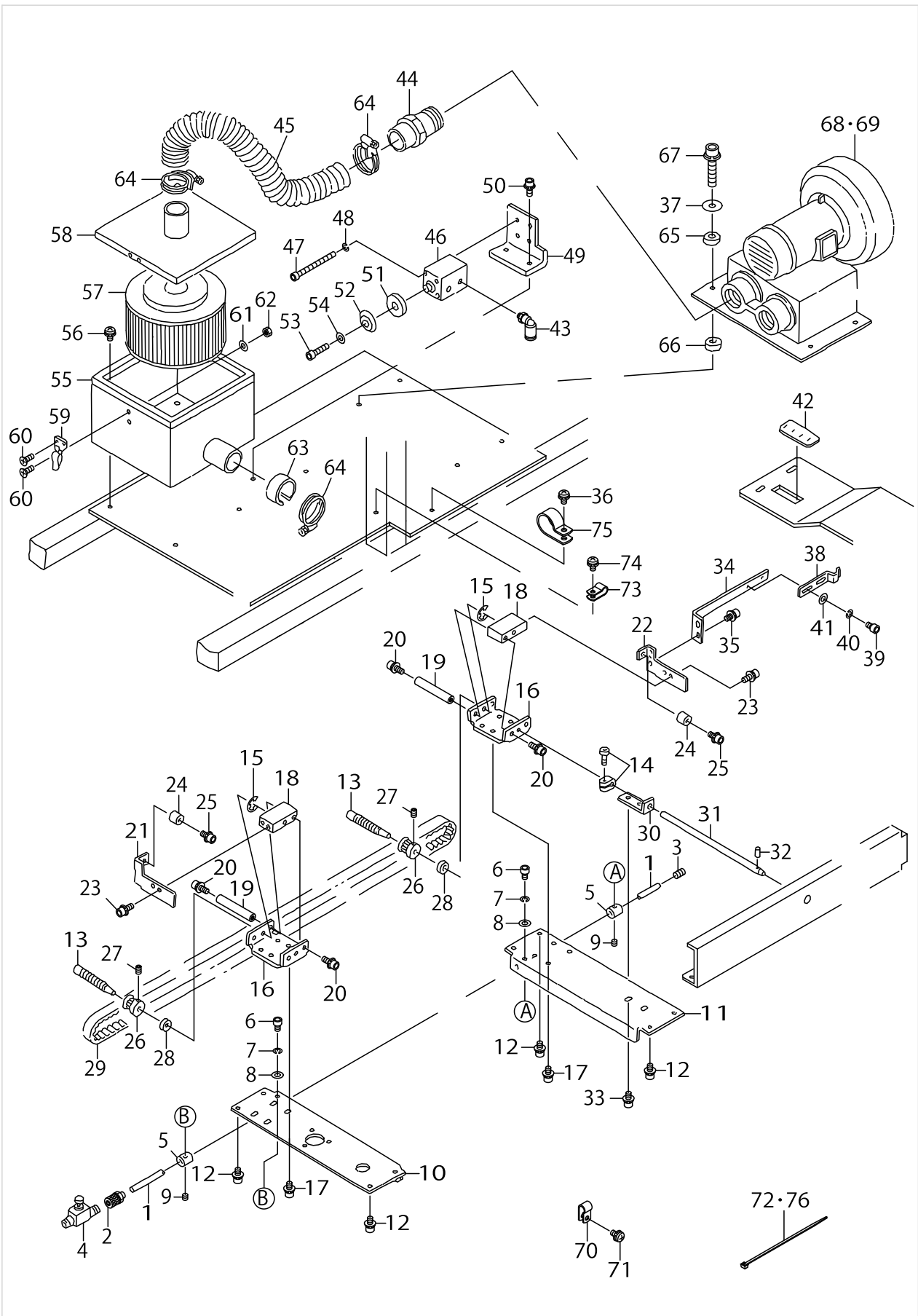

PRESET COMPONENTS (3)

No.	Parts No.	Parts name	Remarks	Level	Cons	Qty
1	G5136172000	BLOW PIPE				1
2	PJ032059008	NIPPLE				1
3	SM8050812TP	SCREW M5X8				1
4	PC012601000	SPEED CONTROLLER				1
5	G5137172000	BLOW PIPE HOLDER				2
6	SM6040602TP	SCREW M4 L=6				2
7	WS0410002KN	SPRING WASHER				2
8	WP0430801SC	WASHER 4.3X9X0.8				2
9	SM8040402TP	SCREW M4X0.7 L=4				2
10	G5319172000	HOLDING BASE, LEFT				1
11	G5320172000	HOLDING BASE, RIGHT				1
12	SL6040892TN	BOLT				8
13	G5322172000	PRESET ADJUSTING SHAFT				2
14	B25198500A0	LOOPER CONNECTING ROD TRUST AS				1
15	RE0600000K0	E-RING 6				2
16	G5321172000A	PRESET ADJUSTING SHAFT HOLDER				2
17	SL6040892TN	BOLT				8
18	G5323172000	PRESET ADJUSTING NUT				2
19	G5324172000A	PRESET ADJUSTING NUT GUIDE				2
20	SL6041092TN	SCREW				4
21	G5325172000	PRESET STOPPER, LEFT				1
22	G5326172000	PRESET STOPPER, RIGHT				1
23	SL6041092TN	SCREW				4
24	G5009172000	STOPPER RUBBER				2
25	SL6040842TN	SCREW M4 L=8				2
26	G5327172000	PRESET ADJUSTING PULLEY				2
27	SM8040602TP	SCREW M4X0.7 L=6				4
28	G5328172000	PULLEY SPACER				2
29	G5329172000	PRESET ADJUSTING BELT				1
30	G5330172000	EXTENSION SHAFT SUPPORT				1
31	G5331172000	ADJUSTING EXTENSION SHAFT				1
32	PS0300162KH	SPRING PIN 3X16				1
33	SL6040892TN	BOLT				2
34	G5332172000	PRESET CHARACTERISTIC SUPPORT				1
35	SL6040892TN	BOLT				2
36	SL4040881SC	SCREW M4 L=8				1
37	WP0651646SC	WASHER				4
38	G5333172000	PRESET CHARACTERISTIC				1
39	SM6040602TP	SCREW M4 L=6				2
40	WS0410002KN	SPRING WASHER				2
41	WP0430801SC	WASHER 4.3X9X0.8				2
42	G5309164000	SCALE				1
43	PJ304040504	ELBOW UNION				1
44	G5345172000	BLOWER JOINT				1
45	G5344172000	VACUUM HOSE, B				1
46	PA160100500	AIR CYLINDER				1
47	SM6033052TP	SCREW				4

PRESET COMPONENTS (3)

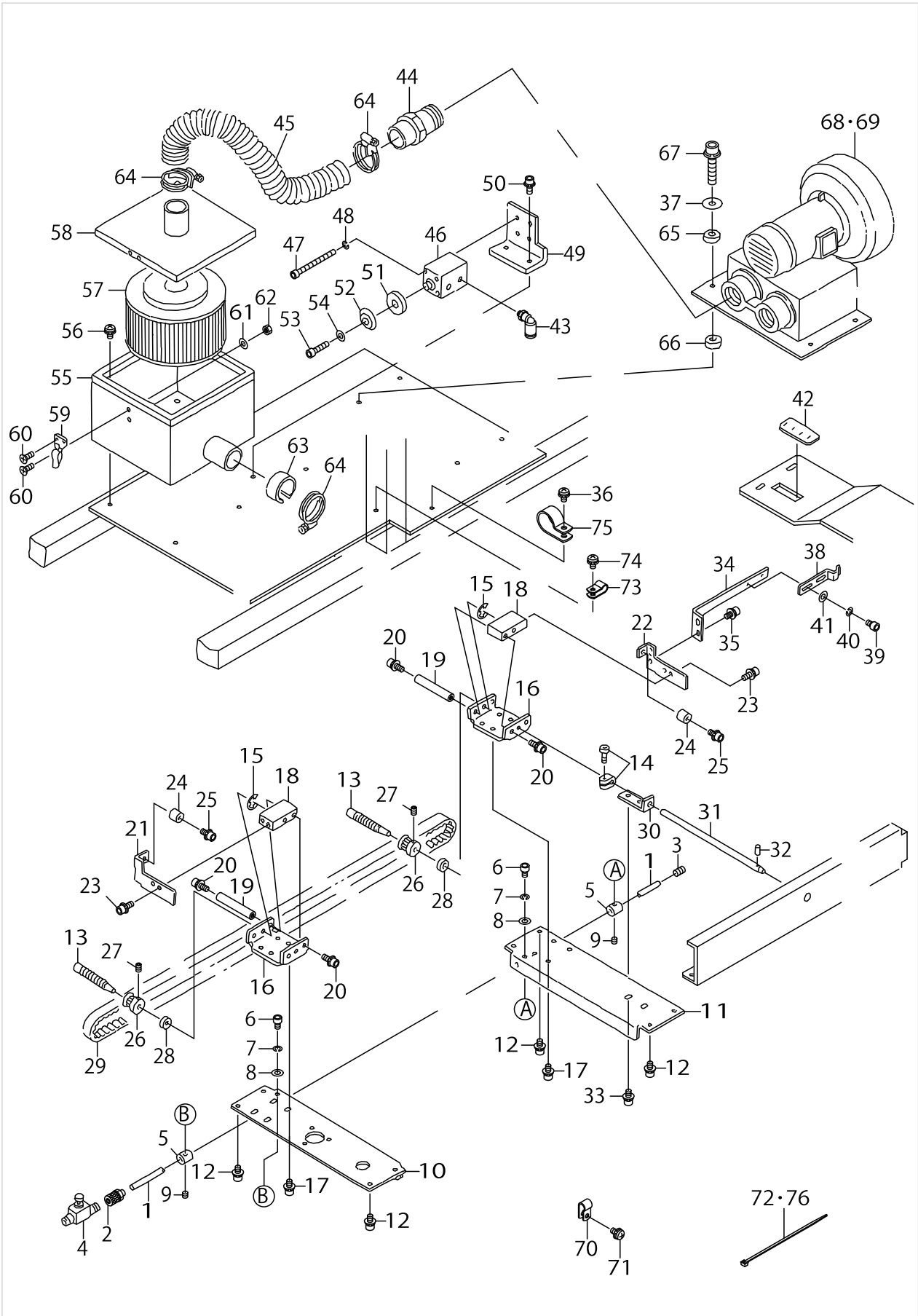

PRESET COMPONENTS (3)

No.	Parts No.	Parts name	Remarks	Level	Cons	Qty
48	WS0310002KN	SPRING WASHER M3				4
49	GMC16003000	VACUUM CYLINDER				1
50	SL6041092TN	SCREW				2
51	GMC16004000	VACUUM CHANGE CYLINDER BOSS				1
52	G5229171000	STOPPOR RUBBER				1
53	SM6041602TP	SCREW M4X0.7 L=16				1
54	WP0430801SC	WASHER 4.3X9X0.8				1
55	GMC160010A0	FILTER BOX ASM.				1
56	SL4040891SC	SCREW M4 L=8				4
57	GMC10004000	FILTER ELEMENT				1
58	GMC100050A0	TOP COVER ASM.				1
59	GMC10007000	METAL FITTINGS				2
60	SM1030801SC	SCREW M3 L=8				8
61	WP0320501SC	WASHER M3				4
62	NM6030001SC	NUT M3				4
63	G5171136000	VACUUM CONTROL PLATE				1
64	G5176136000	HOSE BAND				3
65	B4420373000	CUSHION				4
66	B1123205000	RUBBER PAD				4
67	SL6063042TN	BOLT				4
68	G6951172BA0	HITACHI POWER CORD COMPL.				1
69	G6951172CA0	HITACHI POWER CORD COMPL.				1
70	HX00150000B	CABLE CLIP				7
71	SL4040881SC	SCREW M4 L=8				7
72	EA9500B0100	CABLE BAND				38
73	HX00150000B	CABLE CLIP				2
74	SL4040881SC	SCREW M4 L=8				2
75	HX00150000K	CABLE CLIP				1
76	EA9500B0200	CABLE BAND 150				20

AIR COMPONENTS

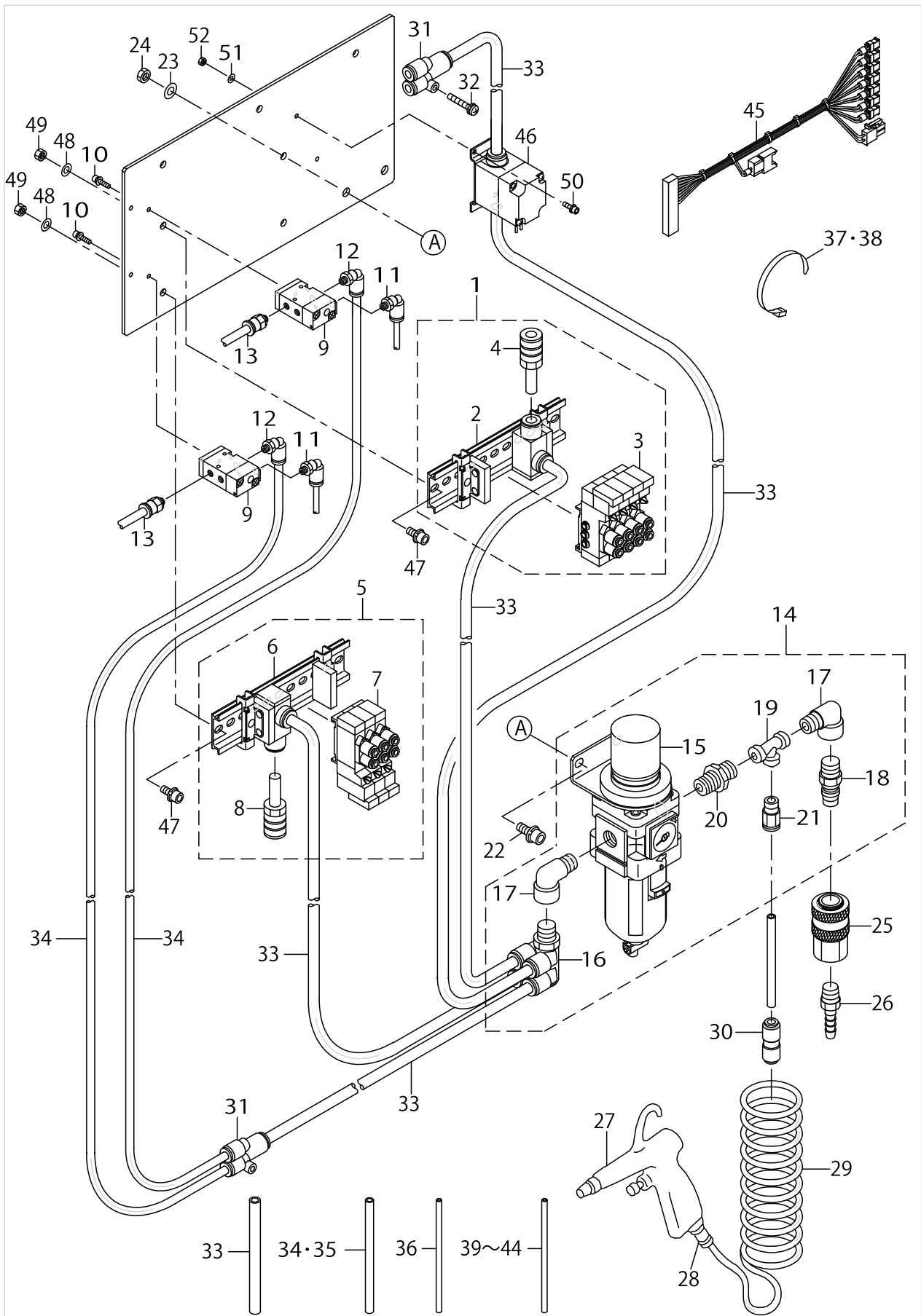

AIR COMPONENTS

No.	Parts No.	Parts name	Remarks	Level	Cons	Qty
1	E41507290A0	ELECTROMAGNETIC VALVE A ASM.				1
2	PV915005000	SOLENOID VALVE INSTALLING BASE		*		1
3	PV150209300	5 PORT ELECTROMAGNETIC VALVE		*		4
4	PX050003000	SILENCER		*		1
5	40000916	MANIFOLD VALVE A ASM				1
6	PV915005000	SOLENOID VALVE INSTALLING BASE		*		1
7	PV150209300	5 PORT ELECTROMAGNETIC VALVE		*		3
8	PX050003000	SILENCER		*		1
9	PV130536000	AIR OPERATE VALVE				2
10	SL6031292TN	BOLT				4
11	PJ304040504	ELBOW UNION				2
12	PJ304060502	ELBOW UNION 6XM5				2
13	PJ301060503	HALF UNION				2
14	40014272	ASSY_REGULATOR				1
15	PF0552160A0	FILTER REGULATOR		*		1
16	PJ309085202	DOUBLE BRANCH UNIVERSAL ELBOW		*		1
17	PJ042520001	ELBOW		*		2
18	PJ025200004	PLUG		*		1
19	PJ050525201	TEE		*		1
20	PJ030520001	RING JOINT (NIPPLE)		*		1
21	PJ301065201	HALF UNION 6XPT1/4		*		1
22	SL6061692TN	BOLT				2
23	WP0641601SC	WASHER				2
24	NM6060003SC	NUT M6				2
25	PJ309005204	SOCKET				1
26	PJ032526001	HOSE NIPPLE				1
27	16111403	AIR GUN				1
28	16111502	SOCKET				1
29	G5458116000	CURLED TUBE				1
30	PJ303060001	STRAIGHT UNION				1
31	PJ308080003	Y-UNION				2
32	SL4042581SC	SCREW				1
33	BT0800501EB	VINYL TUBE				1
34	BT0600401E0	TUBE				10
35	BT0600401EB	TUBE				10
36	BT0400251EB	URETHANE HOSE, BLACK				10.5
37	HX00065000B	CABLE BAND				4
38	HX002920000	BAND				4
39	BT0400251E0	TUBE HOSE, CLEAR				6
40	BT0400251EH	TUBE HOSE, YELLOWISH				6
41	BT0400251EA	TUBE HOSE, BLUE				6
42	BT0400251ED	TUBE HOSE, GREEN				6
43	BT0400251EE	TUBE HOSE, RED				6
44	BT0400251EC	TUBE HOSE, YELLOW				6
45	40016684	AIR VALVE CORD ASSY				1
46	40016685	AIR BLOW VALVE ASSY				1
47	SL6051292TN	BOLT				4

AIR COMPONENTS

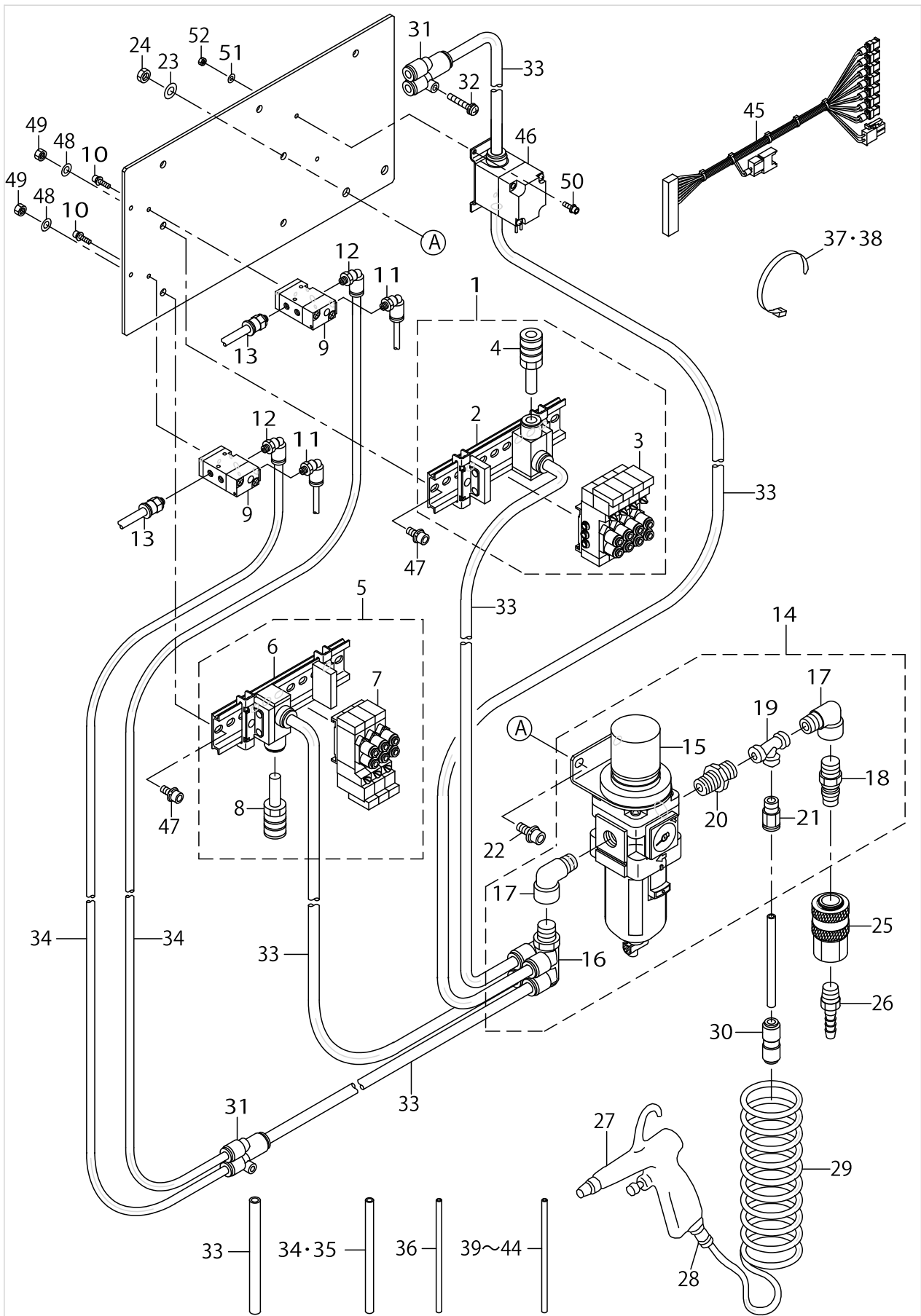

AIR COMPONENTS

No.	Parts No.	Parts name	Remarks	Level	Cons	Qty
48	WP0531001SC	WASHER				4
49	NM6050001SC	NUT M5				4
50	SL6031092TN	SCREW				2
51	WP0320501SC	WASHER M3				2
52	NM6030001SC	NUT M3				2



FRAME COMPONENTS

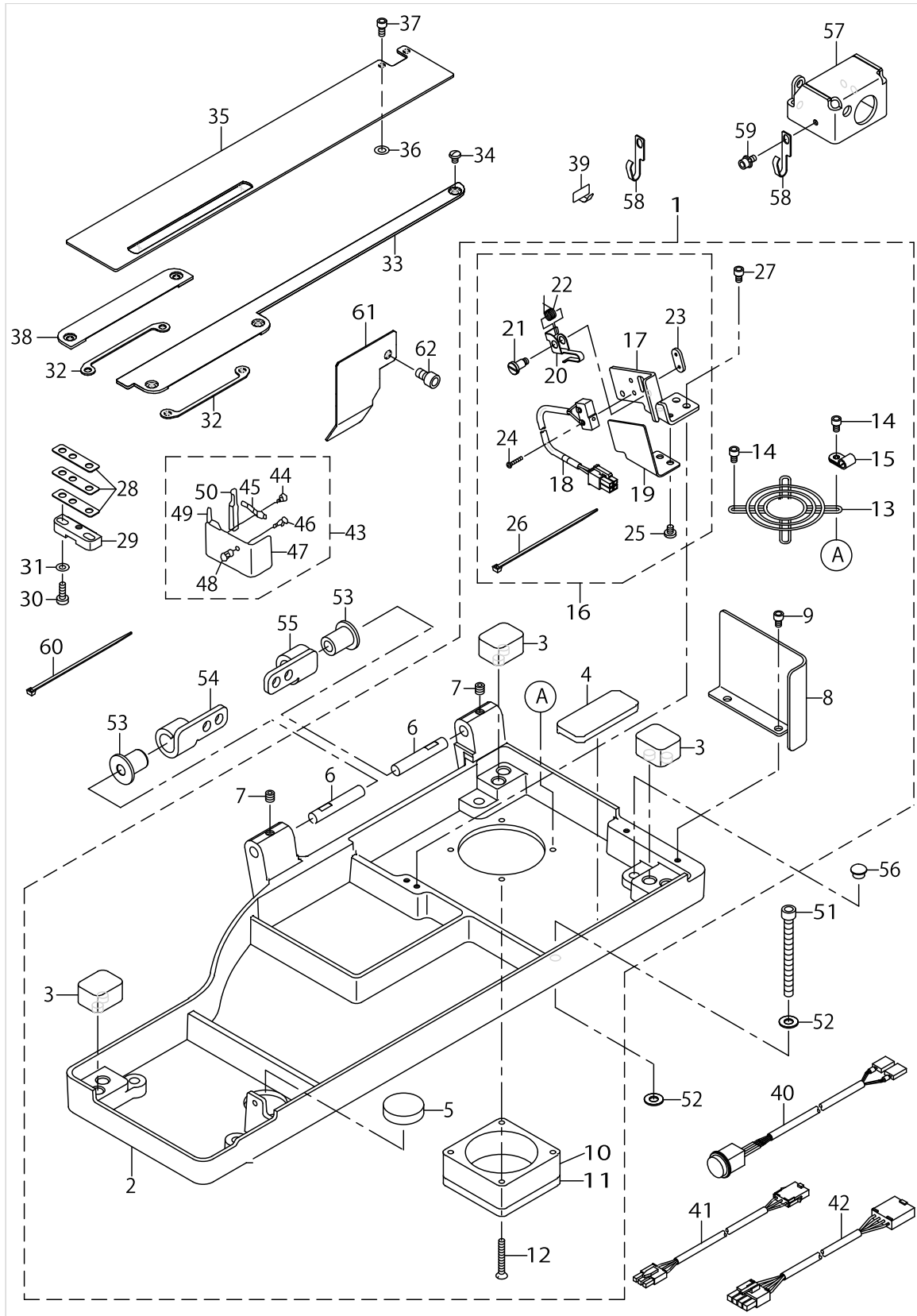

FRAME COMPONENTS

No.	Parts No.	Parts name	Remarks	Level	Cons	Qty
1	40015224	ASSY_BED_BASE_ACF				1
2	40015141	BED_BASE_ACF		*		1
3	40008977	RUBBER C		*		3
4	40008978	RUBBER D		*		1
5	E2002855000	Z STOPPER RUBBER		*		1
6	13700604	HINGE PIN		*		2
7	SM8060612TP	SCREW M6 L=6		*		2
8	40004160	BED_REAR_COVER		*		1
9	SM6040602TP	SCREW M4 L=6		*		2
10	40005403	HEAD FAN MOTOR B ASS'Y		*		1
11	HM000550010	FILTER		*		1
12	SM1043001SP	SCREW M4X0.7 L=30		*		2
13	HM0003800A0	FINGER GUARD		*		1
14	SM6040602TP	SCREW M4 L=6		*		2
15	HX00150000A	CABLE CLAMP		*		1
16	40003495	SAFETY SWITCH ASS'Y		*		1
17	14516603	SAFETY SW BASE		*		1
18	40003496	SAFETY SWITCH CORD ASS'Y		*		1
19	14516900	SAFETY SWITCH COVER		*		1
20	23638109	SAFETY SWITCH ARM		*		1
21	23638307	SAFETY SWITCH ARM SHAFT		*		1
22	23638208	SAFETY SWITCH SPRING		*		1
23	23638406	SAFETY SWITCH NUT		*		1
24	SM4021201SC	SCREW M2 L=12		*		2
25	SS7090520SP	SCREW 9/64-40 L= 4.5		*		2
26	EA9500B0100	CABLE BAND		*		1
27	SM6040602TP	SCREW M4 L=6		*		2
28	40004326	BTT_SPACER				3
29	40004325	POSITIONING_PLATE_BASE				1
30	SM6041200SP	SCREW M4 L=12				2
31	WP0430801SE	WASHER 4.3X9X0.8				2
32	40011319	THROAT_PLATE_BASE_SPACER				2
33	40011317	CARRIER_GUIDE_ACF				1
34	SM5040550TP	SCREW M4 L=5				1
35	40011320	WORK_CLAMP_CARRIER_ACF				1
36	WP0531000SF	WASHER M5				2
37	SM6040802TP	SCREW M4X0.7 L=8				2
38	40011318	THROAT_PLATE_BASE_COVER_ACF				1
39	HX005210000	STICKER				2
40	40017014	PRESET LEDSW ASSY				1
41	40005710	SERVO MOTOR S CODE ASM.				1
42	40005711	SERVO MOTOR P CODE ASM.				1
43	13903356	HOOK COVER COMPL. (ACH)				1
44	SS4110515SP	SCREW 11/64-40 L=5		*		1
45	13704002	HINGE SPRING		*		1
46	SL4030881SF	SCREW M3 L=8		*		1
47	13903307	HOOK COVER (ACH)		*		1

# FRAME COMPONENTS

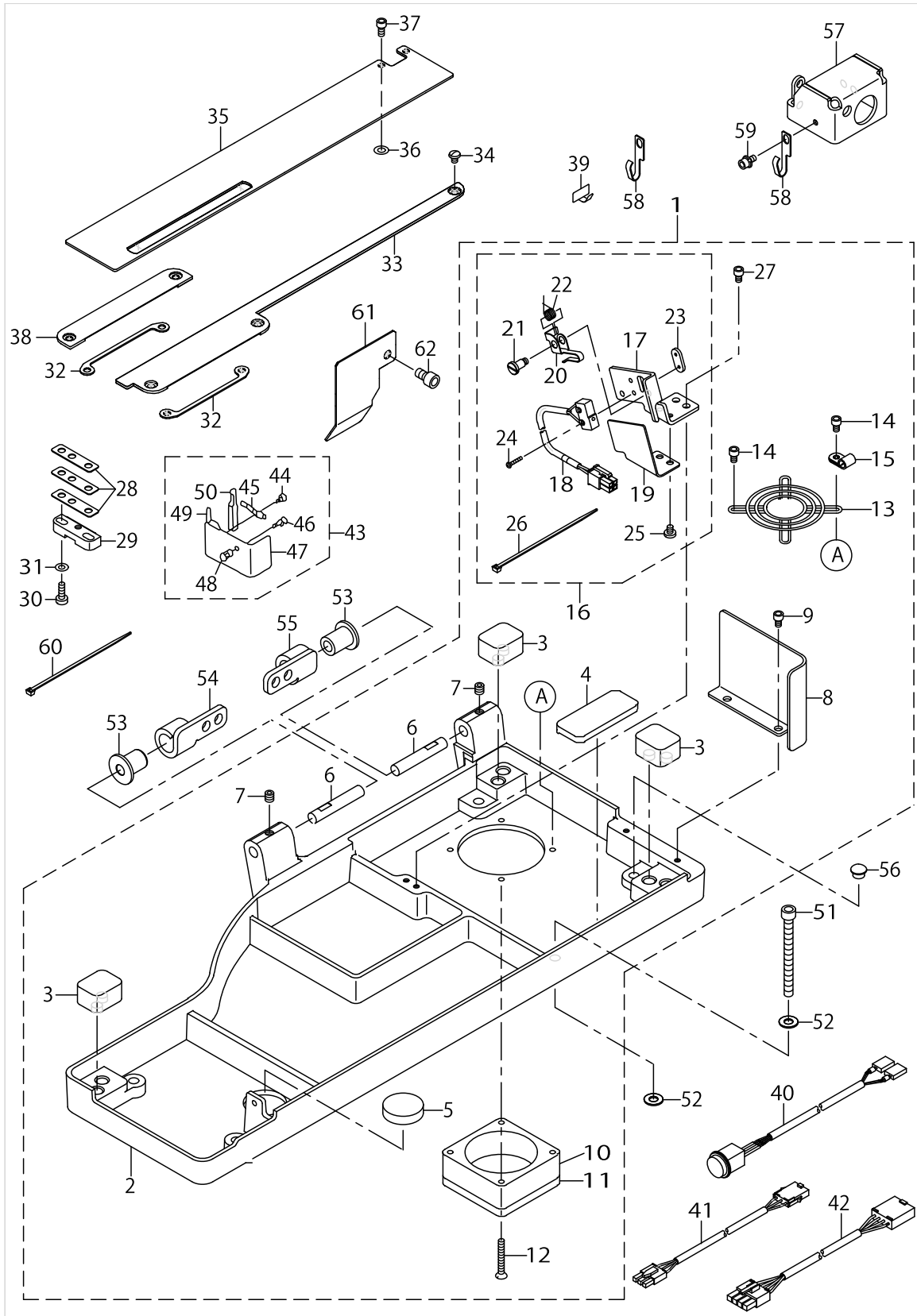

FRAME COMPONENTS

No.	Parts No.	Parts name	Remarks	Level	Cons	Qty
48	13778600	HOOK COVER KNOB		*		1
49	13703905	HINGE PIN		*		1
50	13703806	HOOK OIL SHIELD HINGE		*		1
51	SM6066052TP	SCREW M6 L=60				1
52	WP0621016SH	WASHER				2
53	40006314	HINGE_BUSH				2
54	13700505	HINGE PLATE, B				1
55	13700406	HINGE PLATE, A				1
56	TA0800504R0	PLUG D=8 L=4.5				1
57	40011893	SWITCH_COVER				1
58	26230409	LUBRICATING OIL WICK STOPPER				3
59	SL6040892TN	BOLT				1
60	EA9500B0100	CABLE BAND				1
61	40011013	HOOK_OIL_COVER				1
62	SM6061002TP	SCREW M6 L=10				1

CONTROL BOX COMPONENTS

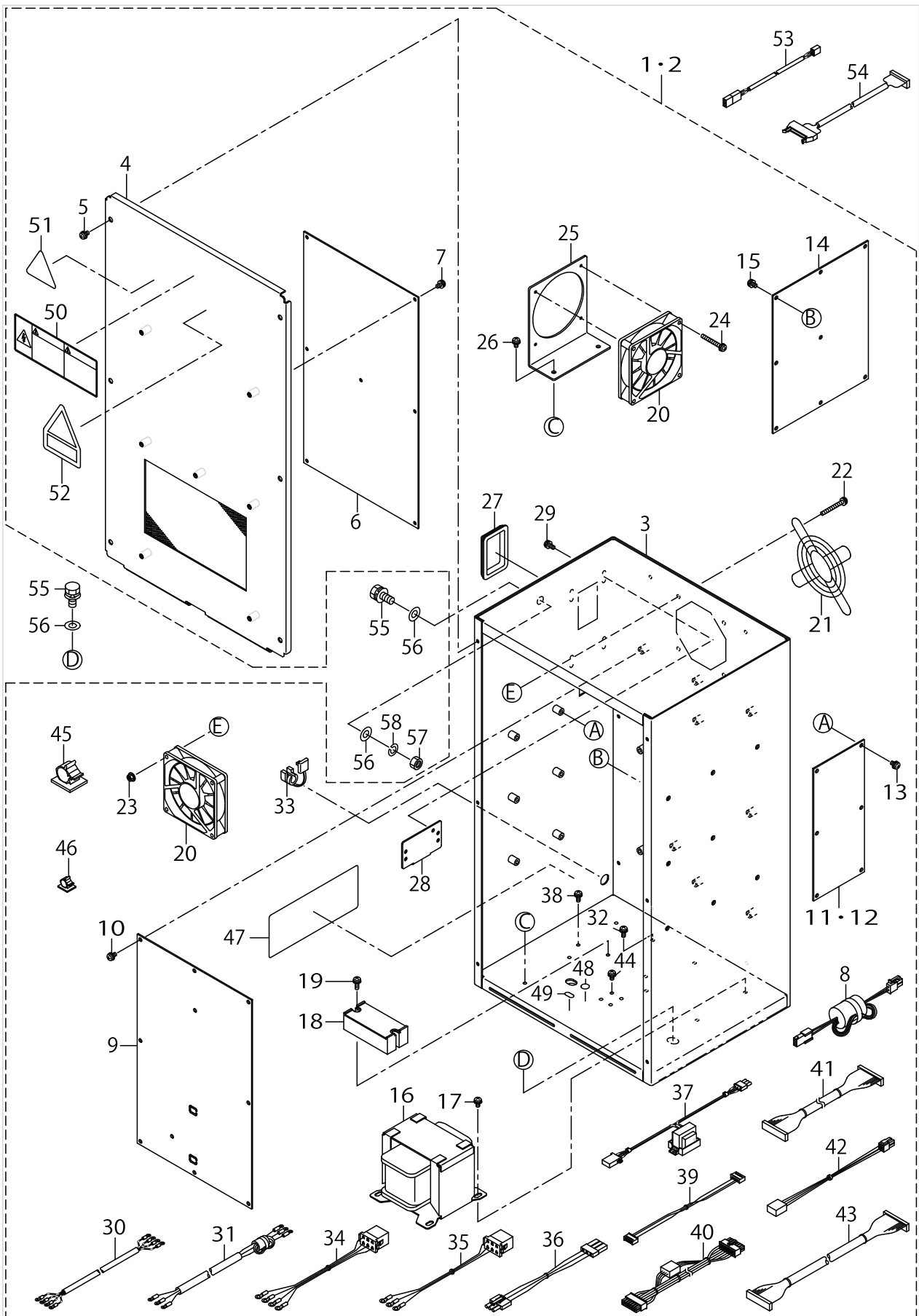

CONTROL BOX COMPONENTS

No.	Parts No.	Parts name	Remarks	Level	Cons	Qty
1	40016393	CONTROL BOX A ASSY	FOR USE IN JAPAN/EXPORT 3φ			1
2	40016394	CONTROL BOX B ASSY	FOR EXPORT 1φ			1
3	40015601	CONTROL BOX		*		1
4	40015602	CONTROL BOX FRONT COVER		*		1
5	SL4040891SC	SCREW M4 L=8		*		6
6	40015556	MAIN PCB B ASSY		*		1
7	SL4040881SC	SCREW M4 L=8		*		7
8	40018093	TRANS JOINT CORD ASSY		*		1
9	40000029	SDC PCB A ASS'Y		*		1
10	SL4040881SC	SCREW M4 L=8		*		10
11	40000056	FLT-T PCB A ASS'Y	FOR USE IN JAPAN/EXPORT 3φ	*		1
12	40000046	FLT-S PCB A ASS'Y	FOR EXPORT 1φ	*		1
13	SL4040881SC	SCREW M4 L=8		*		6
14	40015534	I/O PCB ASSY		*		1
15	SL4040881SC	SCREW M4 L=8		*		8
16	40015554	POWER TRANSFORMER		*		1
17	SL4040891SC	SCREW M4 L=8		*		4
18	HK026650040	TERMINAL STAND		*		1
19	SL4041281SC	SCREW M4X0.7 L=12		*		2
20	40005401	FAN MOTOR ASS'Y		*		2
21	HM000480010	FINGER GUARD		*		1
22	SL4043591SC	SCREW		*		4
23	NM3040520SC	NUT M4		*		4
24	SL4033091SC	SCREW M3 L=30		*		4
25	40005404	FAN MOTOR BRACKET		*		1
26	SL4040891SC	SCREW M4 L=8		*		2
27	HX004070000	BUSH		*		2
28	17845009	CORD FITTING PLATE		*		2
29	SL4041091SC	SCREW M4 L=10		*		4
30	40015609	POWER CORD 3P ASSY	FOR USE IN JAPAN/EXPORT 3φ	*		1
31	40015610	POWER CORD 1P ASSY	FOR EXPORT 1φ	*		1
32	SL4041081SC	SCREW M4 L=10	FOR EXPORT 1φ	*		1
33	HX00410000A	STRAIN RELIEF BUSHING		*		1
34	40015606	FLT INPUT CORD 3P ASSY	FOR USE IN JAPAN/EXPORT 3φ	*		1
35	40015607	FLT INPUT CORD 1P ASSY	FOR EXPORT 1φ	*		1
36	40005393	FLT-SDC CORD P ASS'Y	FOR USE IN JAPAN/EXPORT 3φ	*		1
37	40012038	REACTOR CORD ASSY	FOR EXPORT 1φ	*		1
38	SL4041091SC	SCREW M4 L=10	FOR EXPORT 1φ	*		2
39	40005394	FLT-SDC CORD S ASS'Y		*		1
40	40015617	SDC-MAIN CORD P ASSY		*		1
41	40015618	SDC-MAIN CORD S ASSY		*		1
42	40015608	I/O POWER CORD ASSY		*		1
43	40016401	MAIN-I/O CORD ASSY		*		1
44	SL4040891SC	SCREW M4 L=8		*		4
45	E9609603000	STICKER (LARGE)		*		3
46	E9607603000	STICKER (SMALL)		*		2
47	40015603	RATING LABEL (BLANK)		*		1

# CONTROL BOX COMPONENTS

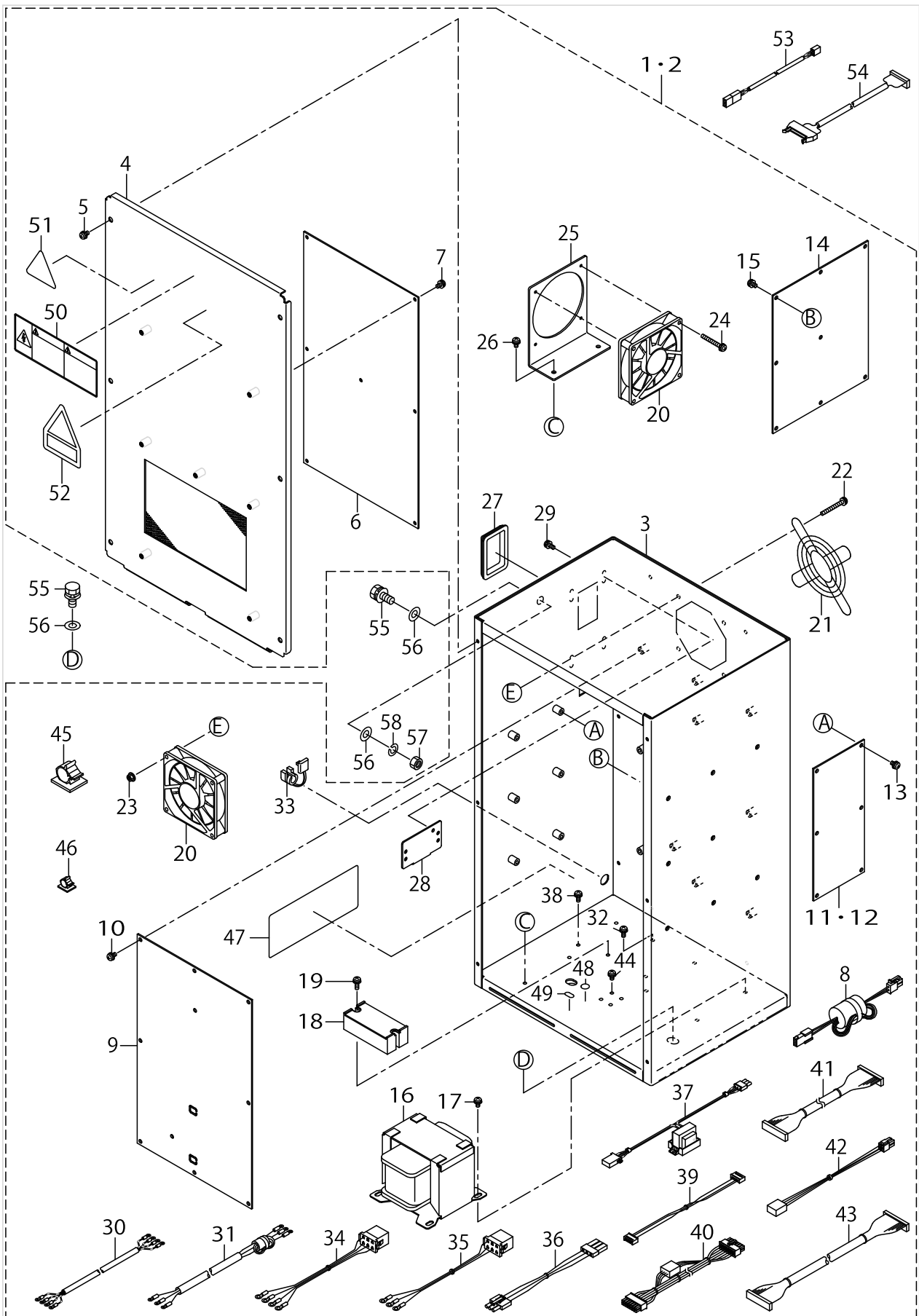

## CONTROL BOX COMPONENTS

No.	Parts No.	Parts name	Remarks	Level	Cons	Qty
48	E9567319000	EARTH MARK		*		1
49	CM200100001	PE MARK LABEL	FOR EXPORT 1 $\phi$	*		1
50	CM300100401	LABEL 3 (LARGE)	FOR USE IN JAPAN/EXPORT 3 $\phi$	*		1
51	CM300100003	VOLTAGE WARNING LABEL(25)	FOR EXPORT 1 $\phi$	*		1
52	CM300400601	VOLTAGE CAUTION LABEL		*		1
53	40017821	HEAD FAN JOINT CORD ASSY				1
54	40017822	PANEL JOINT CORD ASSY	FOR IP-200			1
55	SL9082093SE	SCREW				3
56	WP0841601SC	WASHER 8.4X17.4X1.6				4
57	NM6080001SC	NUT M8X1.25				1
58	WS0820002KN	SPRING WASHER M8				1



OPERATION PANEL COMPONENTS

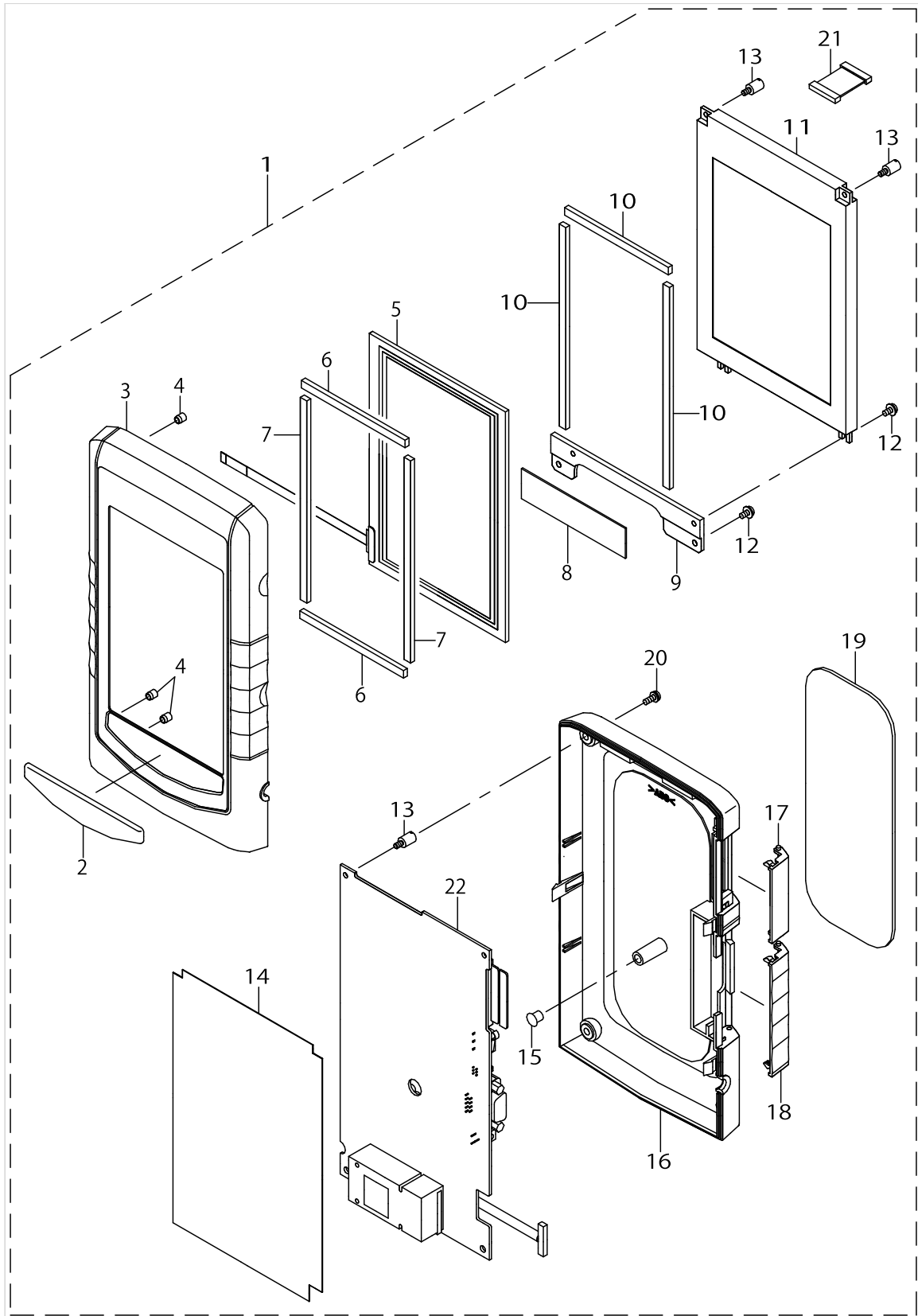

OPERATION PANEL COMPONENTS

No.	Parts No.	Parts name	Remarks	Level	Cons	Qty
1	40016643	IP-200E ASSY				1
2	40000131	NAME_PLATE		*		1
3	40000132	OPERATION_PANEL_F		*		1
4	40000133	INSERT_NUT		*		6
5	A3906010000	TOUCH PANEL		*		1
6	40000134	TTP_H_FELT		*		2
7	40000135	TTP_V_FELT		*		2
8	40000136	KEY_SHEET		*		1
9	40000137	LCD_BASE_PLATE		*		1
10	40000138	BOTHSIDES_TAPE		*		3
11	A39500100A0	LCD		*		1
12	SL4030691SC	SCREW M3X6		*		4
13	40000139	STUD		*		6
14	40000140	ISOLATION_SHEET		*		1
15	TA0550604R0	RUBBER PLUG		*		1
16	40000141	OPERATION_PANEL_R		*		1
17	40000142	SM_COVER		*		1
18	40000143	SERIAL_COVER		*		1
19	40000144	OPERATION_PANEL_MAGNET		*		1
20	SL4030881SC	SCREW M3X8		*		4
21	40000146	LCD_CABLE_ASS'Y		*		1
22	40000148	PANEL_PCB_A_ASS'Y		*		1

WIRING DIAGRAM (1)

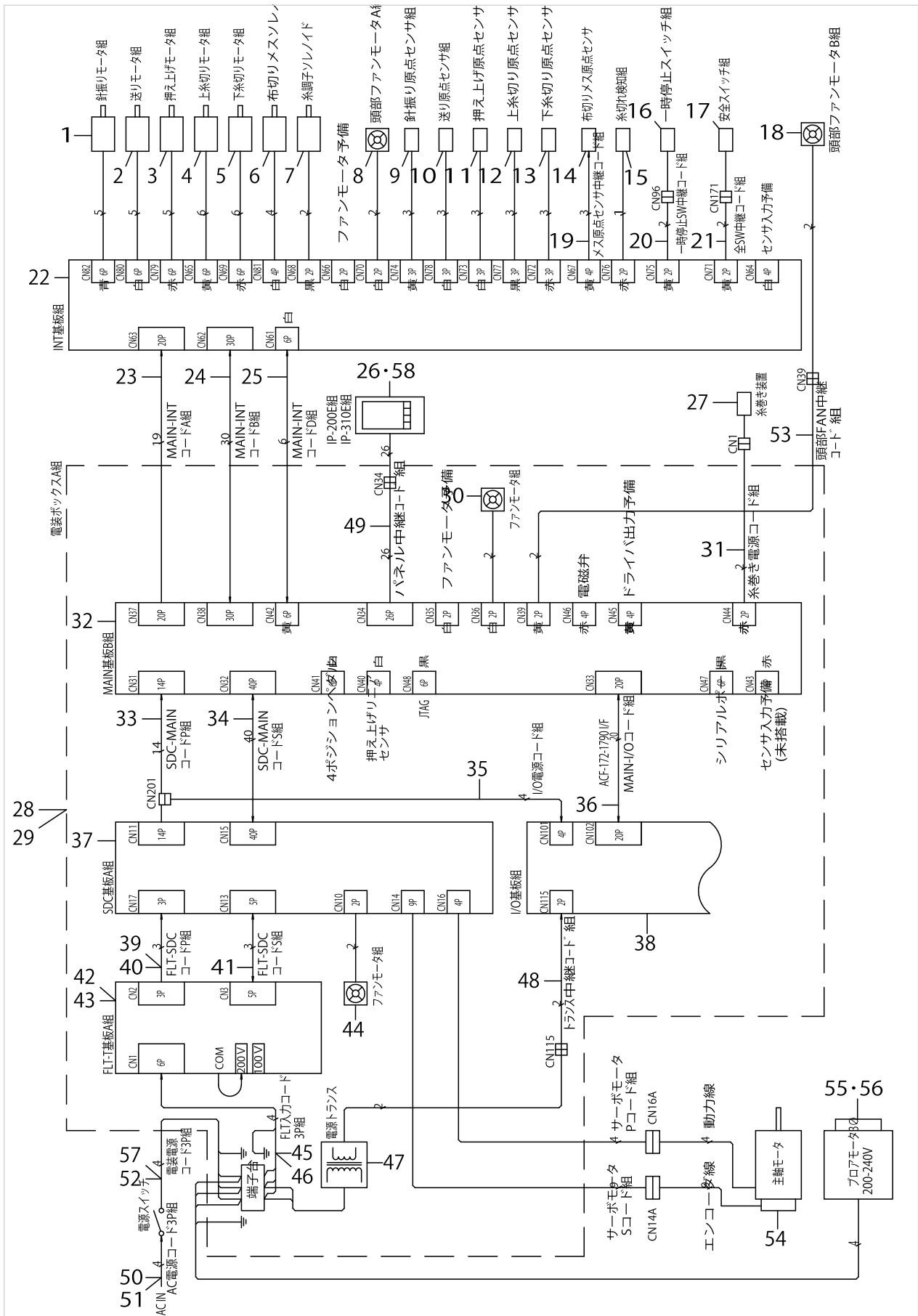

## WIRING DIAGRAM (1)

No.	Parts No.	Parts name	Remarks	Level	Cons	Qty
1	40005371	NEEDLE SWING MOTOR ASS'Y				1
2	40005372	FEED MOTOR ASS'Y				1
3	40005373	CLAMP MOTOR ASS'Y				1
4	40005374	UT TRIM MOTOR ASSY				1
5	40005375	LT TRIM MOTOR ASSY				1
6	40004382	SOLENOID				1
7	40006261	ASSY_AT_SOLENOID				1
8	40005402	HEAD FAN MOTOR A ASS'Y				1
9	40005377	NEEDLE SWING SENSOR ASSY				1
10	40005378	FEED SENSOR ASSY				1
11	40005379	CLAMP SENSOR ASSY				1
12	40005380	UT TRIM SENSOR ASSY				1
13	40005381	LT TRIM SENSOR ASSY				1
14	HD00057000A	PHOTO SENSOR				1
15	40003499	THREAD BREAK DETECTOR A				1
16	32002354	SWITCH ASM.				1
17	40003495	SAFETY SWITCH ASS'Y				1
18	40005403	HEAD FAN MOTOR B ASS'Y				1
19	40005382	CUTTER SENSOR JOINT CORD ASSY				1
20	40005400	PAUSE SWITCH JOINT CORD				1
21	40003497	SAFETY SWITCH JOINT CORD				1
22	40003422	INT PCB ASS'Y				1
23	40016640	MAIN-INT CORD A ASSY				1
24	40016641	MAIN-INT CORD B ASSY				1
25	40016642	MAIN-INT CORD D ASSY				1
26	40016643	IP-200E ASSY	FOR IP-200			1
27	G50011980A0A	BOBBIN WINDER ASM.				1
28	40016393	CONTROL BOX A ASSY	FOR USE IN JAPAN/EXPORT 3φ			1
29	40016394	CONTROL BOX B ASSY	FOR EXPORT 1φ			1
30	40005401	FAN MOTOR ASS'Y		*		1
31	40005405	WINDER CORD ASS'Y		*		1
32	40015556	MAIN PCB B ASSY		*		1
33	40015617	SDC-MAIN CORD P ASSY		*		1
34	40015618	SDC-MAIN CORD S ASSY		*		1
35	40015608	I/O POWER CORD ASSY		*		1
36	40016401	MAIN-I/O CORD ASSY		*		1
37	40000029	SDC PCB A ASS'Y		*		1
38	40015534	I/O PCB ASSY		*		1
39	40005393	FLT-SDC CORD P ASS'Y	FOR USE IN JAPAN/EXPORT 3φ	*		1
40	40012038	REACTOR CORD ASSY	FOR EXPORT 1φ	*		1
41	40005394	FLT-SDC CORD S ASS'Y		*		1
42	40000056	FLT-T PCB A ASS'Y	FOR USE IN JAPAN/EXPORT 3φ	*		1
43	40000046	FLT-S PCB A ASS'Y	FOR EXPORT 1φ	*		1
44	40005401	FAN MOTOR ASS'Y		*		1
45	40015606	FLT INPUT CORD 3P ASSY	FOR USE IN JAPAN/EXPORT 3φ	*		1
46	40015607	FLT INPUT CORD 1P ASSY	FOR EXPORT 1φ	*		1
47	40015554	POWER TRANSFORMER		*		1

WIRING DIAGRAM (1)

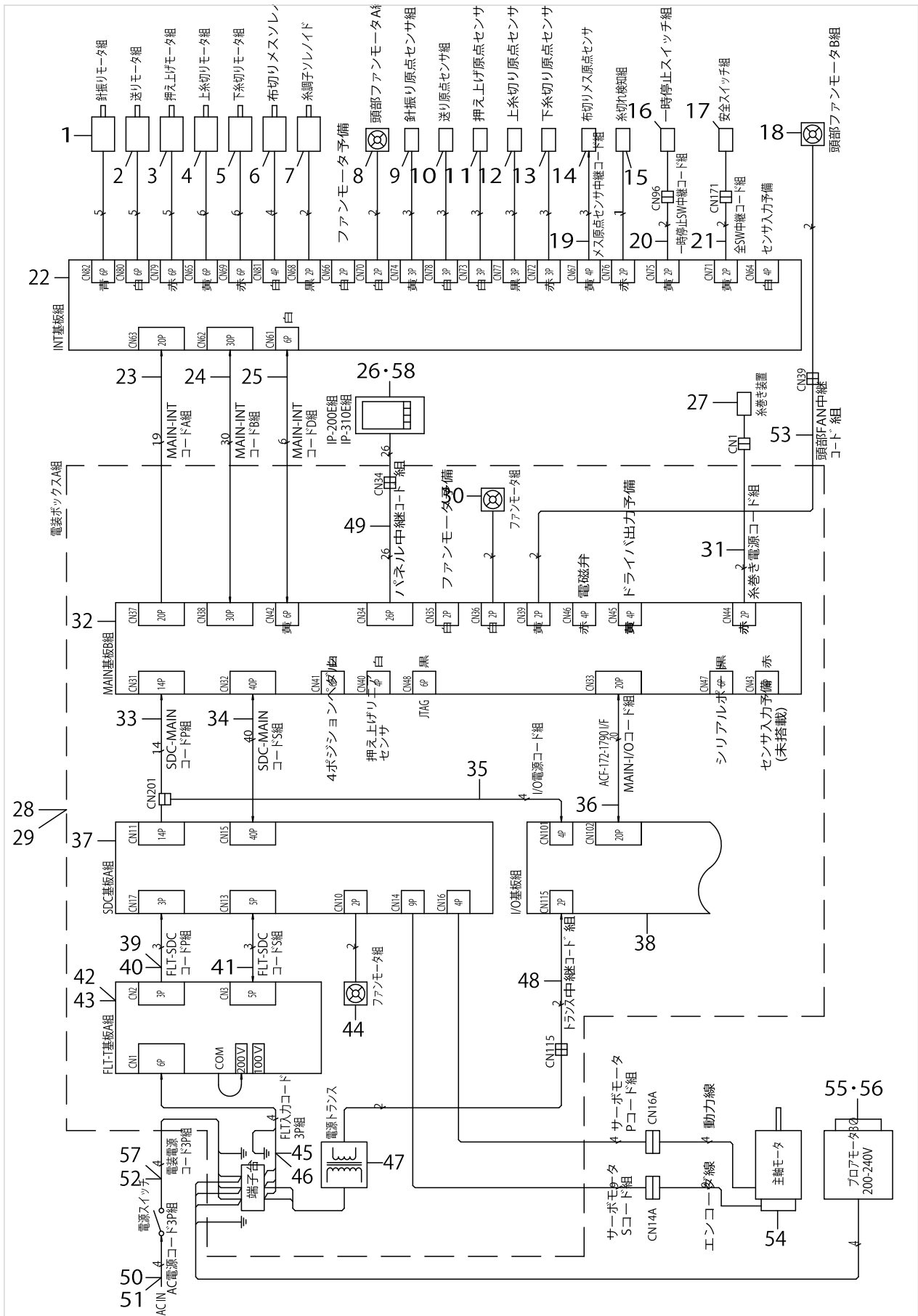

WIRING DIAGRAM (1)

No.	Parts No.	Parts name	Remarks	Level	Cons	Qty
48	40018093	TRANS JOINT CORD ASSY		*		1
49	40017822	PANEL JOINT CORD ASSY	FOR IP-200	*		1
50	40017091	AC POWER CORD 3P ASSY	FOR USE IN JAPAN/EXPORT 3 $\phi$			1
51	40017092	AC POWER CORD 1P ASSY	FOR EXPORT 1 $\phi$			1
52	40015610	POWER CORD 1P ASSY	FOR EXPORT 1 $\phi$			1
53	40017821	HEAD FAN JOINT CORD ASSY				1
54	40003470	AC SERVO MOTOR				1
55	G6951172BA0	HITACHI POWER CORD COMPL.	FOR USE IN JAPAN/EXPORT 3 $\phi$			1
56	G6951172CA0	HITACHI POWER CORD COMPL.	FOR EXPORT 1 $\phi$			1
57	40015609	POWER CORD 3P ASSY	FOR USE IN JAPAN/EXPORT 3 $\phi$			1
58	40059377	IP-310E_STD				1

WIRING DIAGRAM (2)

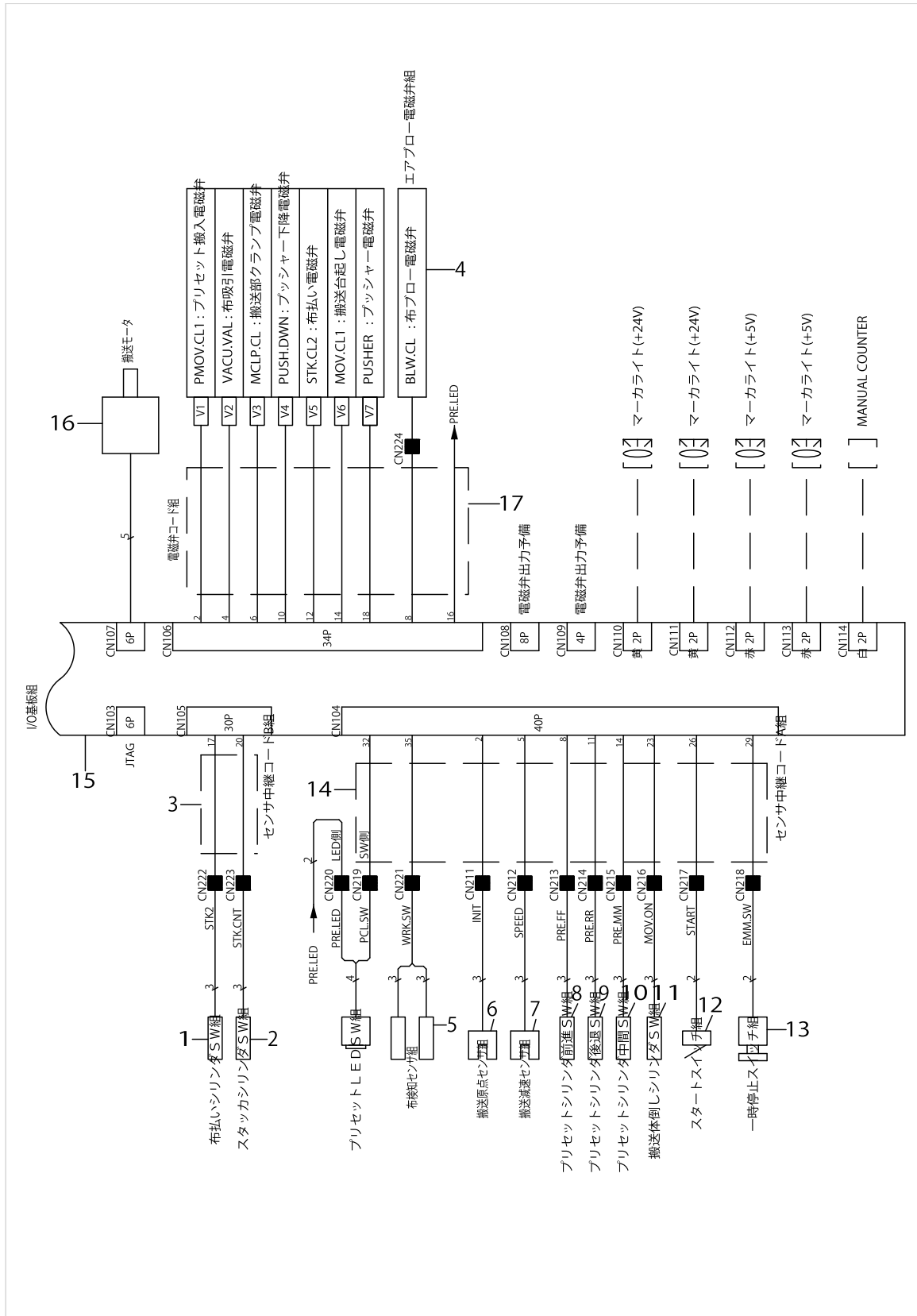

WIRING DIAGRAM (2)

No.	Parts No.	Parts name	Remarks	Level	Cons	Qty
1	40016851	STACKER2 CYL SW ASSY				1
2	40016850	STACKER CNT CYL SW ASSY				1
3	40016853	PRESET LEDSW ASSY				1
4	40016685	AIR BLOW VALVE ASSY				1
5	40016845	CARRIER ORG SENSOR ASSY				1
6	40016842	CARRIER DECEL SENSOR ASSY				1
7	40016843	PRESET CYL FWD SW ASSY				1
8	40016846	PRESET CYL BKWD SW ASSY				1
9	40016848	PRESET CYL MID SW ASSY				1
10	40016847	CARRIER MOV CYL SW ASSY				1
11	40016849	START SWITCH ASSY				1
12	40016844	PAUSE SWITCH ASSY				1
13	40015562	SENSOR JOINT CORD A ASSY				1
14	40016852	I/O PCB ASSY				1
15	40015534	CARRIER MOTOR				1
16	40016666	AIR VALVE CORD ASSY				1
17	40016684	AIR VALVE CORD ASSY				1



ACCESSORIES COMPONENTS (1)

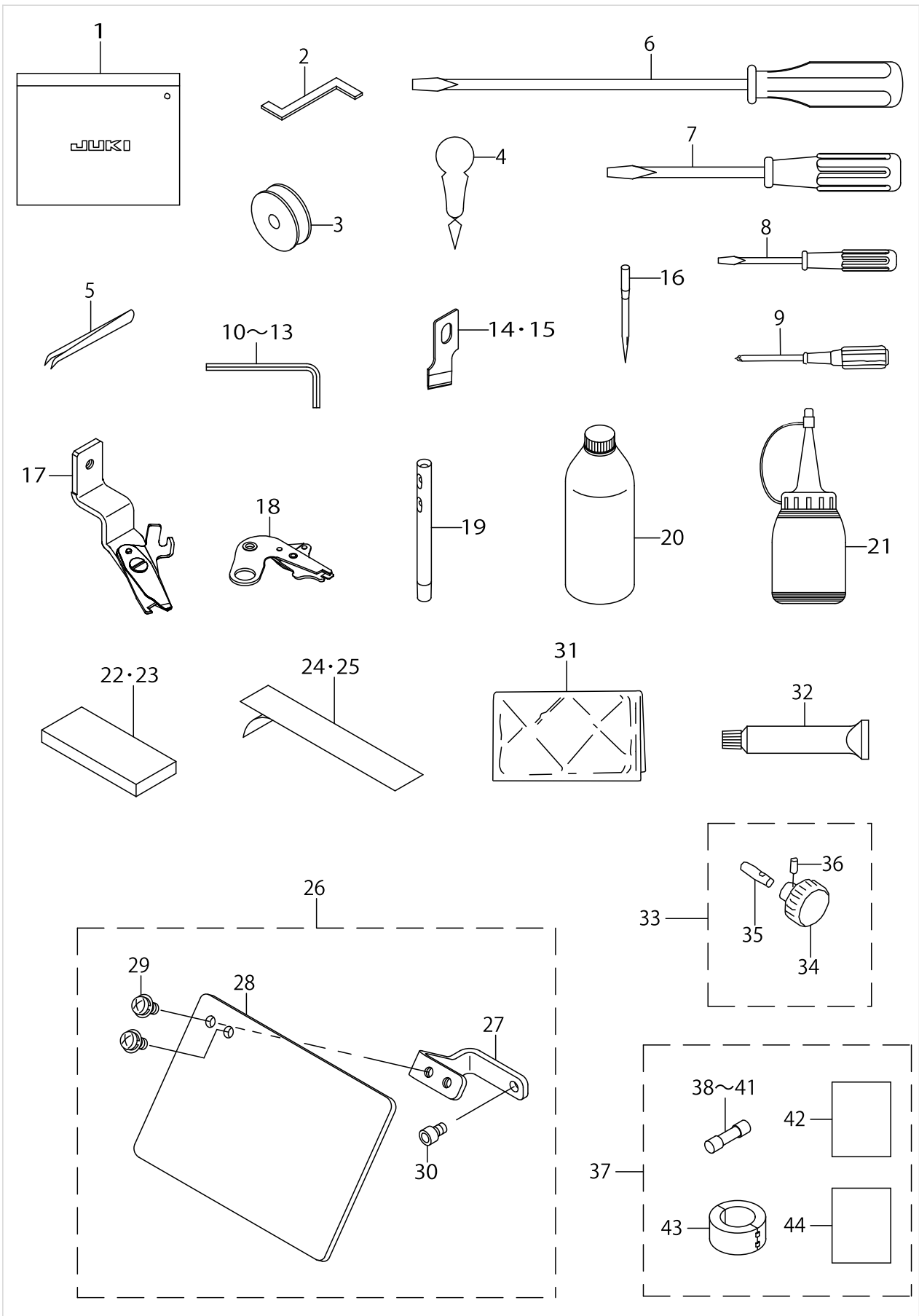

ACCESSORIES COMPONENTS (1)

No.	Parts No.	Parts name	Remarks	Level	Cons	Qty
1	22932800	ACCESSORIE BAG				1
2	40015430	TIMING_GAUGE_ACF				1
3	40009148	BOBBIN				1
4	B9107761000	THREAD PASSING INSTRUMENT				1
5	B9204804000	TWEEZERS				1
6	22933006	SCREW DRIVER,LARGE				1
7	22933105	SCREW DRIVER,MIDDLE				1
8	22933204	SCREW DRIVER,SMALL				1
9	MA117002000	RECESSED HEAD DRIVER (NO.1)				1
10	J106600000D	HEXAGONAL WRENCH KEY				1
11	GCT02904000	SPANNER				1
12	GCT02905000	SPANNER				1
13	J106600000A	HEXAGONAL ROD SPANNER 1.5MM				1
14	B2702047K00A	KNIFE 3/8				1
15	B2702047M00A	KNIFE 5/8				1
16	MDP5J0B1102	NEEDLE DPX5 #11J-2				1
17	40004255	ASSY_UTT_TRIMMER				1
18	40004311	BT_TRIMMER				1
19	22502504	THREAD GUIDE BAR				1
20	MDFRX1600C0	DEFRIX OIL NO.1(600CC)				1
21	J1067000000	OILER				1
22	G5134172000	CLAMP CUSHION, LARGE				2
23	G5135172000	CLAMP CUSHION, SMALL				2
24	G5138172000	CLAMP TABLE LINER				1
25	G5302172000	PRESET TABLE LINER				5
26	40052047	ASSY SAFETY PLATE B				1
27	40049424	SAFETY PLATE BASE		*		1
28	B3120372000	SAFETY PLATE		*		1
29	SL4040891SC	SCREW M4 L=8		*		2
30	SM6040602TP	SCREW M4 L=6		*		1
31	26234005	VINYL COVER				1
32	40006323	JUKI GREASE A TUBE				1
33	G53471720A0	PRESET ADJUSTING HANDLE ASM.				1
34	G5347172000	PRESET ADJUSTING HANDLE		*		1
35	G5348172000	PRESET ADJUSTING HANDLE BOSS		*		1
36	PS0300162KH	SPRING PIN 3X16		*		1
37	40016665	CONTROL BOX ACCESORY B ASSY				1
38	HF0013050P0	FUSE 5A		*		1
39	HF0013040P0	FUSE 4A		*		1
40	HF00130315S	FUSE 3.15A 250V REF. NO.112		*		1
41	HF003000200	FUSE 2A (220/240V)		*		1
42	29275005	EMC PRODUCTION DECLARATION		*		1
43	HN002460000	CORES		*		1
44	40015521	CORE SETUP MANUAL		*		1

ACCESSORIES COMPONENTS (2)

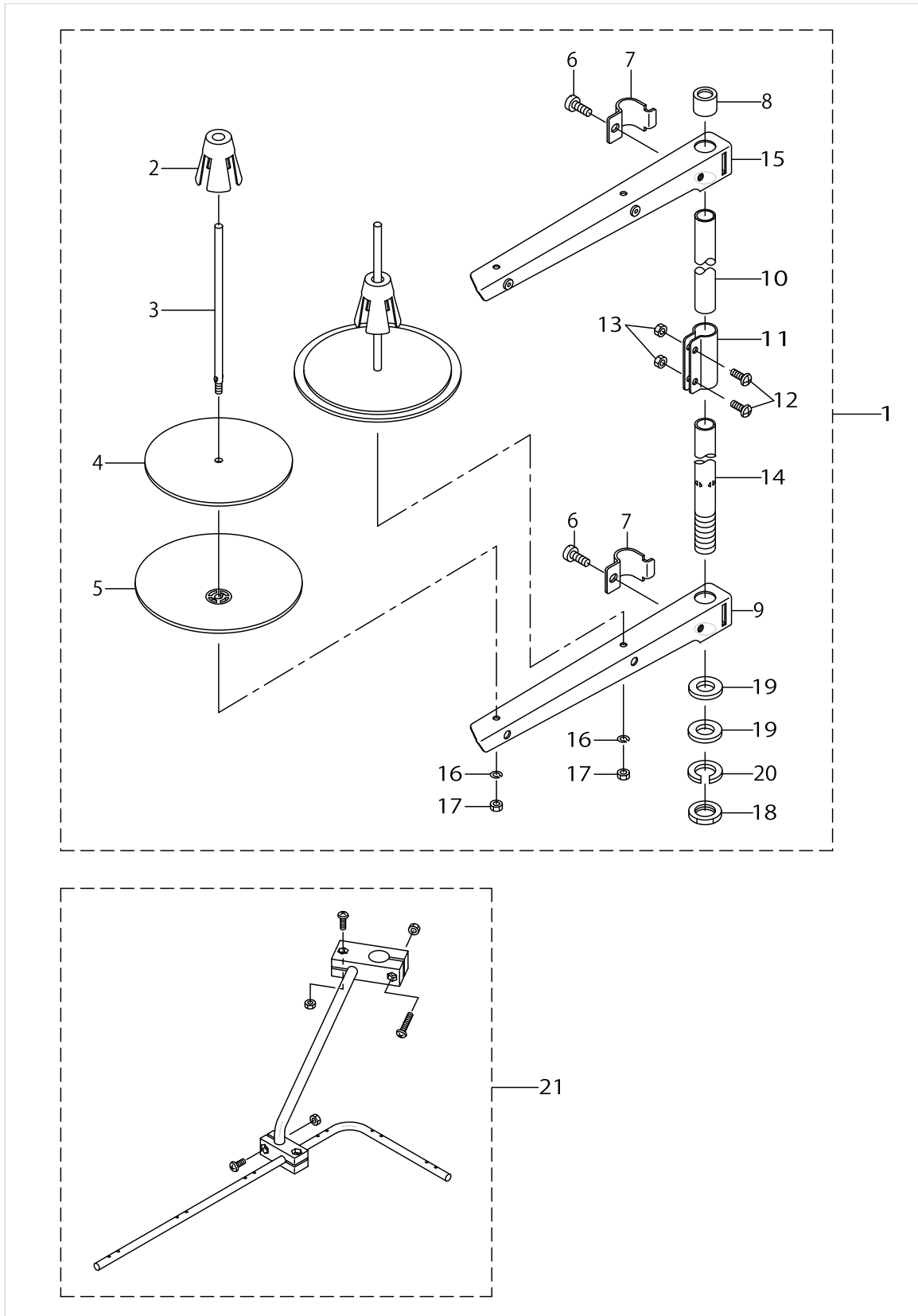

ACCESSORIES COMPONENTS (2)

No.	Parts No.	Parts name	Remarks	Level	Cons	Qty
1	22930358	THREAD STAND ASM.				1
2	22931109	SPOOL RETAINER		*		2
3	22931000	SPOOL PIN		*		2
4	22930903	SPOOL REST CUSHION		*		2
5	22930804	SPOOL REST		*		2
6	SM6061610SC	SCREW M6 L=16		*		2
7	22930705	THREAD GUIDE ARM JOINT		*		2
8	22931406	SPOOL REST ROD RUBBER CAP		*		1
9	22930507	SPOOL REST ARM		*		1
10	22930408	SPOOL REST ROD, UPPER		*		1
11	22931307	SPOOL REST ROD JOINT		*		1
12	SM4051405SE	SCREW M5 L=14		*		2
13	NM6050001SE	NUT M5		*		2
14	22930309	SPOOL REST ROD, LOWER		*		1
15	22930556	THREAD STANDING ARM ASM.		*		1
16	WS0510002KN	SPRING WASHER		*		2
17	NM6050001SE	NUT M5		*		2
18	NM6160511SE	NUT M16X1.5		*		1
19	WP1612616SE	WASHER 16X30X2.6		*		2
20	WS1643202KR	SPRING WASHER		*		1
21	26910059	THREAD GUIDE ARM ASM.				1

OPTIONAL DEVICE COMPONENTS (1)

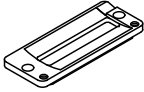
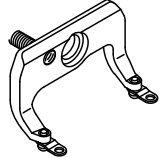
		Cloth Cutting Knife 布切りメス	Presser Foot (Length of Cloth Cutting Knife) 押え (布切りメス長さ)			Presser Foot (Presser Size) 押え足 (押えサイズ)
						
		標準 Standard	標準 Standard	メリヤス用 For Hoisier	標準 (振り巾6mm) Standard (For swing width 6mm)	標準 Standard
inch	mm	Ref.no	Ref.no	Ref.no	Ref.no	Ref.no
1/4	6.4	1	12 (6.4 ~ 19.1 mm)	15 (6.4 ~ 19.1 mm)	18 (6.4 ~ 31.8 mm)	19 (Type 1)
3/8	9.5	2				
7/16	11.1	3				
1/2	12.7	4				
9/16	14.3	5				
5/8	15.9	6				
1 1/16	17.5	7				
3/4	19.1	8				
7/8	22.2	9	13 (6.4 ~ 25.4 mm)	16 (6.4 ~ 25.4 mm)	20 (Type 2)	
1	25.4	10	14 (6.4 ~ 31.8mm)	17 (6.4 ~ 31.8 mm)		
1-1/4	31.8	11				21 (Type 3)

OPTIONAL DEVICE COMPONENTS (1)

No.	Parts No.	Parts name	Remarks	Level	Cons	Qty
1	B2702047F00	KNIFE 1/4				1
2	B2702047K00A	KNIFE 3/8				1
3	B2702047I00	KNIFE (7/16)				1
4	B2702047L00A	KNIFE 1/2				1
5	B2702047V00	KNIFE 9/16				1
6	B2702047M00A	KNIFE 5/8				1
7	B2702047A00	KNIFE 11/16				1
8	B2702047N00	KNIFE 3/4				1
9	B2702047P00	KNIFE 7/8				1
10	B2702047Q00A	KNIFE 1				1
11	B2702047S00A	KNIFE 1-1/4				1
12	B1552781000A	PRESSER				1
13	B1552782000	WORK CLAMP CHECK, 2				1
14	B1552783000	WORK CLAMP CHECK, 3				1
15	D1508771K00A	LATCH WORK CLAMP CHECK				1
16	D1508772K00	WORK CLAMP CHECK (2K)				1
17	D1508773K00	WORK CLAMP CHECK (3K)				1
18	14524409	WORK CLAMP CHECK				1
19	D1511771KA0A	WORK CLAMP CHECK HOLDER ASM.				1
20	D1511772KA0	WORK CLAMP CHECK HOLDER				1
21	D1511773KA0	WORK CLAMP CHECK HOLDER				1

OPTIONAL DEVICE COMPONENTS (2)

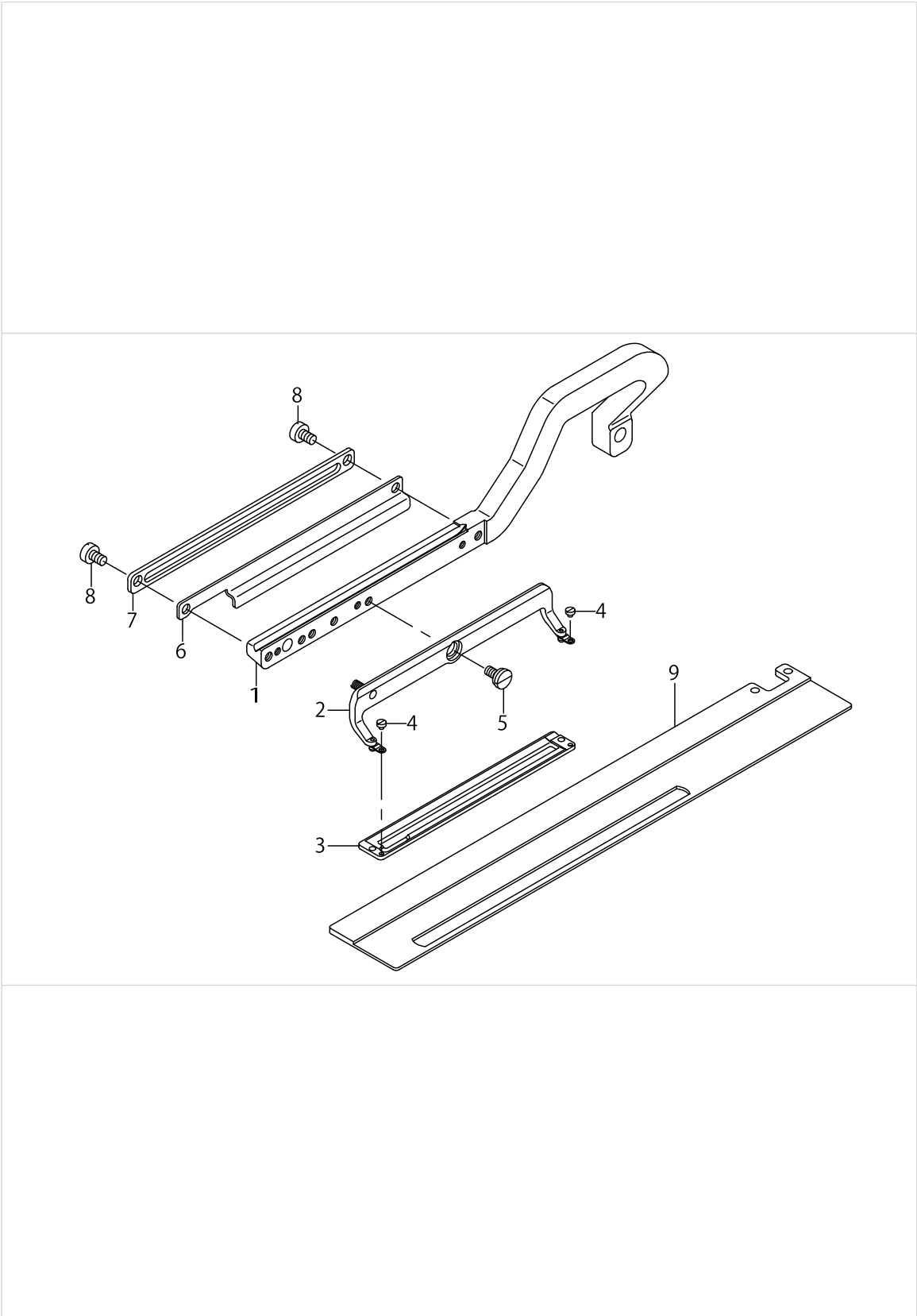

OPTIONAL DEVICE COMPONENTS (2)

No.	Parts No.	Parts name	Remarks	Level	Cons	Qty
1	40006335	WORK_CLAMP_ARM_120				1
2	40008646	ASSY_WORK_CLAMP_CHECK HOLDER_1				1
3	40008658	WORK_CLAMP_120				1
4	SS6060210SP	SCREW 3/32-56 L= 1.9				4
5	SD0790203SP	HINGE SCREW D=7.94 H=2				2
6	40006341	UTT_CLOSE_CAM_120				1
7	40006342	LIFTING_PLATE_120				1
8	SM6050800SP	SCREW M5 L=8				2
9	40014871	WORK_CLAMP_CARRIER_ACF_120				1





## HOW TO MAKE USE OF THIS PARTS LIST

### 1.Explanation of codes

1)"\*"mark.....means this part is changed from the previous parts book.

As to the details of the change, refer to the "List for information of change".

2)"#01".....refer to "Note" explanation at bottom of page.

### 2.Codes on the "Qty" column

• Each numeral indicates the number of parts required.

• "0.1" and "2.5" indicate the length (in meters) of the respective parts.

3.Parentheses mean that the corresponding part is a subpart that constructs an assembly part.

4.Dotted lines on the Figures indicate assembly parts.

### 1."注記"欄の記号説明

1) "\*"印.....前回のパーツブックに比較して今回変更された部品を意味します。

変更内容は、"変更情報リスト"を参照してください。

2) "#01".....ページ下の"注記"の説明を参照してください。

2.数量欄の数字は、個数を表し、0.1、2.5等の数値は、長さ（単位メートル）を表します。

3.数量欄の（ ）は、組部品を構成している子部品であることを意味します。

4.イラストページの-----枠は、組構成であることを意味します。

# NUMERICAL INDEX OF PARTS

PART NO	PAGE	REF NO.	PART NO	PAGE	REF NO.	PART NO	PAGE	REF NO.
11041100	30	6	22933105	56	7	40004326	40	28
11155108	2	44	22933204	56	8	40004382	50	6
11155801	6	46	23638109	40	20	40005371	50	1
11156007	6	45	23638208	40	22	40005372	50	2
11206505	14	8	23638307	40	21	40005373	50	3
13700406	42	55	23638406	40	23	40005374	50	4
13700505	42	54	26230409	42	58	40005375	50	5
13700604	40	6	26234005	56	31	40005377	50	9
13703806	42	50	26910059	58	21	40005378	50	10
13703905	42	49	29275005	56	42	40005379	50	11
13704002	40	45	32002354	50	16	40005380	50	12
13741806	30	5	40000029	44	9	40005381	50	13
13774906	2	18	40000029	50	37	40005382	50	19
13778600	42	48	40000046	44	11-12	40005393	44	36
13903307	40	47	40000046	50	43	40005393	50	39
13903356	40	43	40000056	44	11-12	40005394	44	39
14101208	4	61	40000056	50	42	40005394	50	41
14516603	40	17	40000131	48	2	40005400	50	20
14516900	40	19	40000132	48	3	40005401	44	20
14524409	60	18	40000133	48	4	40005401	50	44
16111403	36	27	40000134	48	6	40005402	50	8
16111502	36	28	40000135	48	7	40005403	40	10
16136905	14	6	40000136	48	8	40005403	50	18
16136905	18	4	40000137	48	9	40005404	44	25
16136905	22	27	40000138	48	10	40005405	50	31
16556300	26	41	40000139	48	13	40005710	40	41
16556300	30	32	40000140	48	14	40005711	40	42
16870206	4	68	40000141	48	16	40006261	50	7
17845009	44	28	40000142	48	17	40006314	42	53
22502504	56	19	40000143	48	18	40006323	56	32
22573505	2	31	40000144	48	19	40006335	62	1
22930309	58	14	40000146	48	21	40006341	62	6
22930358	58	1	40000148	48	22	40006342	62	7
22930408	58	10	40000916	36	5	40008646	62	2
22930507	58	9	40003422	50	22	40008658	62	3
22930556	58	15	40003470	52	54	40008977	40	3
22930705	58	7	40003495	40	16	40008978	40	4
22930804	58	5	40003495	50	17	40009148	56	3
22930903	58	4	40003496	40	18	40011013	42	61
22931000	58	3	40003497	50	21	40011317	40	33
22931109	58	2	40003499	50	15	40011318	40	38
22931307	58	11	40004160	40	8	40011319	40	32
22931406	58	8	40004255	56	17	40011320	40	35
22932800	56	1	40004311	56	18	40011321	2	29
22933006	56	6	40004325	40	29	40011422	2	27

# NUMERICAL INDEX OF PARTS

PART NO	PAGE	REF NO.	PART NO	PAGE	REF NO.	PART NO	PAGE	REF NO.
40011423	2	37	40016101	18	2	40017091	8	54·55
40011893	42	57	40016101	22	25	40017091	52	50
40012038	44	37	40016393	44	1·2	40017092	8	54·55
40012038	50	40	40016393	50	28	40017092	52	51
40012529	16	25	40016394	44	1·2	40017821	46	53
40012545	16	14	40016394	50	29	40017821	52	53
40012546	16	22	40016401	44	43	40017822	46	54
40012547	16	20	40016401	50	36	40017822	52	49
40012548	16	24	40016640	50	23	40018093	44	8
40014271	2	1	40016641	50	24	40018093	52	48
40014272	36	14	40016642	50	25	40019864	6	20
40014871	62	9	40016643	48	1	40019865	2	4
40015134	4	67	40016643	50	26·58	40020109	14	5
40015141	40	2	40016665	56	37	40049424	56	27
40015224	40	1	40016666	16	16	40052047	56	26
40015430	56	2	40016666	54	16	40059377	52	26·58
40015521	56	44	40016684	36	45	A3906010000	48	5
40015534	44	14	40016684	54	17	A39500100A0	48	11
40015534	50	38	40016685	36	46	B1123205000	34	66
40015534	54	15	40016685	54	4	B1504761A00	18	40
40015554	44	16	40016842	16	39	B1505040000	18	37
40015554	50	47	40016842	54	6	B1552781000A	60	12
40015556	44	6	40016843	16	40	B1552782000	60	13
40015556	50	32	40016843	54	7	B1552783000	60	14
40015562	8	61	40016844	4	79	B25198500A0	32	14
40015562	54	13	40016844	54	12	B2544280000	2	24
40015601	44	3	40016845	8	60	B2702047A00	60	7
40015602	44	4	40016845	54	5	B2702047F00	60	1
40015603	44	47	40016846	30	44	B2702047I00	60	3
40015606	44	34	40016846	54	8	B2702047K00A	56	14·15
40015606	50	45	40016847	30	45	B2702047K00A	60	2
40015607	44	35	40016847	54	10	B2702047L00A	60	4
40015607	50	46	40016848	30	9	B2702047M00A	56	14·15
40015608	44	42	40016848	54	9	B2702047M00A	60	6
40015608	50	35	40016849	14	24	B2702047N00	60	8
40015609	44	30	40016849	54	11	B2702047P00	60	9
40015609	52	57	40016850	18	44	B2702047Q00A	60	10
40015610	44	31	40016850	54	2	B2702047S00A	60	11
40015610	52	52	40016851	18	45	B2702047V00	60	5
40015611	6	1	40016851	54	1	B3120372000	56	28
40015612	6	27	40016852	8	58	B3207470000	2	23
40015617	44	40	40016852	54	14	B4420373000	34	65
40015617	50	33	40016853	8	59	B9107761000	56	4
40015618	44	41	40016853	54	3	B9204804000	56	5
40015618	50	34	40017014	40	40	BT0400251E0	36	39~44

# NUMERICAL INDEX OF PARTS

PART NO	PAGE	REF NO.	PART NO	PAGE	REF NO.	PART NO	PAGE	REF NO.
BT0400251EA	36	39~44	G5008172000	2	15	G5113172000	14	4
BT0400251EB	4	76	G5009172000	2	19	G5114172000	14	12
BT0400251EB	36	36	G5009172000	16	12	G5115172000	10	1
BT0400251EC	36	39~44	G5009172000	32	24	G5115172000	18	14
BT0400251ED	36	39~44	G5010164000	16	1	G5116172000	10	4
BT0400251EE	36	39~44	G5010172000	2	21	G5116172000	24	50
BT0400251EH	36	39~44	G5011172000	2	45	G5117172000	10	6
BT0600401E0	36	34·35	G5013172000	6	36	G5118172000	10	7
BT0600401EB	36	34·35	G5014172000	6	8	G5119172000	10	9
BT0800501EB	36	33	G5015172000	6	10	G5120172000	14	27
CM200100001	46	49	G5016162000	6	25	G5121172000	14	30
CM300100003	46	51	G5016172000	6	12	G5122172000	10	12
CM300100401	46	50	G5017172000	6	14	G51231720A0	10	16
CM300200003	4	69·70	G5018172000	6	17	G5124172000	10	27
CM300200004	4	69·70	G5020172000	2	2	G5125172000	10	28
CM300400601	46	52	G5022172000	2	6	G5126172000	10	31
CM301300001	4	71	G5023172000	6	22	G5127172000	10	32
D1508771K00A	60	15	G5024172000	2	7	G5128172000	10	34
D1508772K00	60	16	G5025172000	6	23	G5129172000	10	37
D1508773K00	60	17	G5026162000	6	33	G5130172000	10	38
D1511771KA0A	60	19	G5026172000	6	31	G5131172000	10	40
D1511772KA0	60	20	G5027172000	6	42	G5132172000	10	41
D1511773KA0	60	21	G50281720A0	4	48	G5133172000	10	42
E2002855000	40	5	G5029172000	4	49	G5134172000	10	46
E41507290A0	36	1	G50301720A0	4	50	G5134172000	56	22·23
E9567319000	46	48	G5031164000	4	64	G5135172000	10	47
E9607603000	44	46	G5031172000	4	51	G5135172000	56	22·23
E9609603000	44	45	G5032164000	4	65	G5136172000	8	50
EA9500B0100	4	73~75	G5032172000	4	52	G5136172000	12	48
EA9500B0100	8	70·71	G5033172000	4	62	G5136172000	22	45
EA9500B0100	10	14	G5034171000	2	8	G5136172000	32	1
EA9500B0100	16	37	G5034171000	6	24	G5137172000	12	52
EA9500B0100	34	72·76	G5037172000	6	6	G5137172000	32	5
EA9500B0100	40	60	G5101172000	14	1	G5138161000	14	29
EA9500B0100	42	60	G5102164000	14	32	G5138172000	10	18
EA9500B0200	16	38	G5102172000	16	6	G5138172000	56	24·25
EA9500B0200	34	72·76	G5103172000	16	7	G5139172000	16	28
G1015192000	2	38	G5104172000	16	9	G5140172000	10	30
G1016192000	2	39	G5105172000	16	10	G5144162000	10	35
G1017192000	2	35	G5106172000	14	19	G5144162000	22	13
G50011980A0A	50	27	G5107172000	14	21	G5150162000	16	33
G5003172000	6	3	G5108172000	16	43	G5153171000	16	35
G50051720A0	2	10	G5110172000	16	30	G5171136000	34	63
G5006172000	2	11	G5111172000	16	32	G5176136000	28	50
G5007172000	2	13	G5112172000	14	3	G5176136000	34	64

# NUMERICAL INDEX OF PARTS

PART NO	PAGE	REF NO.	PART NO	PAGE	REF NO.	PART NO	PAGE	REF NO.
G5201172000	22	1	G53071720A0	26	11	G5348172000	56	35
G5202172000	22	2	G5308172000	26	12	G5352171000A	26	24
G5203172000A	22	11	G5309164000	32	42	G5454161000	16	36
G5204171000	14	14	G5309172000	26	14	G5458116000	36	29
G5204171000	18	22	G5310172000	26	16	G5808172000	26	27
G5204171000	22	37	G5311172000	26	19	G5809172000	26	1
G5204172000A	22	4	G5312172000	26	21	G5810172000	26	29
G5205172000	22	9	G5313172000	26	23	G5904172000	28	48
G5207172000	22	15	G5314172000	30	1	G6010003000	26	28
G5208172000	22	16	G5315172000	30	3	G6801172000	4	80
G5209172000	22	18	G53161720A0	30	4	G6802172000	4	81
G5210172000	22	19	G5317172000	30	17	G6803172000	4	82
G5211172000	22	21	G5318172000	30	20	G6951172BA0	34	68·69
G5212172000	8	49	G5319172000	32	10	G6951172BA0	52	55·56
G5212172000	22	23	G5320172000	32	11	G6951172CA0	34	68·69
G5213172000	18	1	G5321172000A	32	16	G6951172CA0	52	55·56
G5213172000	22	24	G5322172000	32	13	GBR01910000	2	26
G5214172000	18	8	G5323172000	32	18	GCT02904000	56	10~13
G5214172000	22	31	G5324172000A	32	19	GCT02905000	56	10~13
G52151720A0	18	12	G5325172000	32	21	GMC10004000	34	57
G5216172000	18	20	G5326172000	32	22	GMC100050A0	34	58
G5216172000	26	36	G5327172000	32	26	GMC10007000	34	59
G5216172000	30	27	G5328172000	32	28	GMC160010A0	34	55
G5217172000	6	47	G5329172000	32	29	GMC16003000	34	49
G5218172000	18	17	G5330172000	32	30	GMC16004000	34	51
G5219172000	18	25	G5331172000	32	31	GMC16007000	30	36
G5220172000	18	27	G5332172000	32	34	HA004860000	8	56
G52211720A0	18	29	G5333172000	32	38	HD00057000A	50	14
G5222172000	18	31	G5334172000	26	25	HF00130315S	56	38~41
G5223172000	18	32	G5335172000	26	30	HF0013040P0	56	38~41
G5224172000	18	33	G5336172000	26	32	HF0013050P0	56	38~41
G5225172000	18	41	G5336172000	30	23	HF003000200	56	38~41
G5226172000	18	42	G5337172000	26	34	HK026650040	44	18
G5227172000	22	41	G5337172000	30	25	HM0003800A0	40	13
G5229171000	34	52	G5338172000	26	43	HM000480010	44	21
G5238171000	14	17	G5338172000	30	34	HM000550010	40	11
G5238171000	18	23	G5341172000	30	12	HN002460000	56	43
G5239171000	18	6	G5342172000	30	13	HX00055000C	18	28
G5239171000	22	29	G5343172000	26	45	HX00065000B	4	73~75
G5302172000	26	3	G5344172000	32	45	HX00065000B	8	70·71
G5302172000	56	24·25	G5345172000	32	44	HX00065000B	20	48
G5303172000	26	4	G5346172000	26	47	HX00065000B	36	37·38
G5304172000	26	7	G53461720A0	26	46	HX001500000	4	72
G5305172000	26	9	G5347172000	56	34	HX001500000	8	62
G5306172000	26	10	G53471720A0	56	33	HX00150000A	40	15

# NUMERICAL INDEX OF PARTS

PART NO	PAGE	REF NO.	PART NO	PAGE	REF NO.	PART NO	PAGE	REF NO.
HX00150000B	8	64	NM6080003SC	18	34	PJ304040504	22	35
HX00150000B	16	41	NM6160001SC	4	66	PJ304040504	28	51
HX00150000B	18	46	NM6160511SE	58	18	PJ304040504	30	40
HX00150000B	24	54	NS6200710SN	2	34	PJ304040504	32	43
HX00150000B	34	73	PA1001016A0	26	39	PJ304040504	36	11
HX00150000C	24	56	PA1001016A0	30	30	PJ304060502	36	12
HX00150000D	4	55	PA1008501A0	22	33	PJ308040002	22	36
HX00150000D	8	66	PA160100500	10	20	PJ308040002	30	41
HX00150000F	2	47	PA160100500	32	46	PJ308080003	36	31
HX00150000F	12	55	PA200251500	14	10	PJ309005204	36	25
HX00150000H	8	68	PA2005015A0	18	19	PJ309085202	36	16
HX00150000K	6	29	PA2007508A0	18	10	PS0300162KH	32	32
HX00150000K	34	75	PA320500200	30	7	PS0300162KH	56	36
HX00150000S	28	52	PA900024000	22	10	PV010503000	30	38
HX002920000	4	73~75	PA900041000	14	15	PV130536000	36	9
HX002920000	36	37·38	PA900042000	30	10	PV150209300	36	7
HX004070000	44	27	PC010508000	14	11	PV915005000	36	6
HX00410000A	44	33	PC010508000	26	40	PX050003000	36	8
HX005210000	40	39	PC010508000	30	31	PX906003000	14	18
J106600000A	56	10~13	PC010519000	10	21	PX906004000	30	11
J106600000D	56	10~13	PC012401000	22	53	RE0300000K0	26	44
J1067000000	56	21	PC012401000	24	53	RE0300000K0	30	35
MAI17002000	56	9	PC012601000	4	77	RE0500000K0	10	33
MDFRX1600C0	56	20	PC012601000	8	52	RE0600000K0	32	15
MDP5J0B1102	56	16	PC012601000	22	47	RE0700000K0	18	21
MTJMGC00000	4	59	PC012601000	32	4	RE0700000K0	26	37
MTJMGC00000	18	36	PC015108000	18	11	RE0700000K0	30	28
MTJMS000030	2	30	PC015108000	30	8	SB112001100	16	27
NM3040520SC	44	23	PF0552160A0	36	15	SB708000100	22	8
NM6030001SC	6	40	PJ025200004	36	18	SB710000200	26	18
NM6030001SC	34	62	PJ030520001	36	20	SD0790203SP	62	5
NM6030001SC	38	52	PJ032059008	8	53	SL4030681SC	6	41
NM6040001SC	6	44	PJ032059008	24	49	SL4030691SC	48	12
NM6040003SC	10	45	PJ032059008	32	2	SL4030881SC	48	20
NM6050001SC	16	5	PJ032526001	36	26	SL4030881SF	40	46
NM6050001SC	38	49	PJ042520001	36	17	SL4031691SC	2	17
NM6050001SE	58	17	PJ050525201	36	19	SL4033091SC	44	24
NM6050003SC	30	16	PJ301040502	10	22	SL4040691SC	22	22
NM6060001SC	2	43	PJ301040502	30	39	SL4040881SC	4	60
NM6060001SC	22	44	PJ301060503	12	49	SL4040881SC	8	69
NM6060003SC	10	11	PJ301060503	36	13	SL4040881SC	12	56
NM6060003SC	14	31	PJ301065201	36	21	SL4040881SC	16	42
NM6060003SC	36	24	PJ303040002	10	15	SL4040881SC	18	47
NM6080001SC	22	40	PJ303060001	6	5	SL4040881SC	24	57
NM6080001SC	46	57	PJ303060001	36	30	SL4040881SC	28	53

# NUMERICAL INDEX OF PARTS

PART NO	PAGE	REF NO.	PART NO	PAGE	REF NO.	PART NO	PAGE	REF NO.
SL4040881SC	32	74	SL6041642TN	30	33	SM4021201SC	40	24
SL4040881SC	34	74	SL6051092TN	10	39	SM4040801SN	10	25
SL4040881SC	44	15	SL6051092TN	22	12	SM4040801SN	26	5
SL4040891SC	4	83	SL6051092TN	26	22	SM4041401SC	6	43
SL4040891SC	10	43	SL6051092TN	30	14	SM4051405SE	58	12
SL4040891SC	34	56	SL6051292TN	26	33	SM5040550TP	40	34
SL4040891SC	44	44	SL6051292TN	30	24	SM6020350SP	26	8
SL4040891SC	56	29	SL6051292TN	36	47	SM6033052TP	10	23
SL4041081SC	6	30	SL6051442TN	14	2	SM6033052TP	32	47
SL4041081SC	44	32	SL6051442TN	16	11	SM6040602TP	32	39
SL4041091SC	2	3	SL6051492TN	6	4	SM6040602TP	40	27
SL4041091SC	28	49	SL6051492TN	14	28	SM6040602TP	56	30
SL4041091SC	44	38	SL6051492TN	16	44	SM6040802TP	40	37
SL4041281SC	44	19	SL6051492TN	26	17	SM6041200SP	40	30
SL4042081SC	4	78	SL6052042TN	16	2	SM6041602TP	34	53
SL4042091SC	24	48	SL6052092TN	16	31	SM6042502TP	30	42
SL4042581SC	36	32	SL6061292TN	2	25	SM6050800SP	62	8
SL4043591SC	44	22	SL6061292TN	18	43	SM6051002TN	8	57
SL4051091SC	16	29	SL6061292TN	22	30	SM6051802TP	16	17
SL6031092TN	38	50	SL6061492TN	6	19	SM6052502TP	22	26
SL6031292TN	36	10	SL6061692TN	2	57	SM6061002TP	42	62
SL6031642TN	16	34	SL6061692TN	4	57	SM6061202TN	4	58
SL6032092TN	16	21	SL6061692TN	6	2	SM6061202TP	10	10
SL6040642TN	26	26	SL6061692TN	18	30	SM6061610SC	58	6
SL6040842TN	2	20	SL6061692TN	22	32	SM6062502TP	18	3
SL6040842TN	16	13	SL6061692TN	36	22	SM6062502TP	30	18
SL6040842TN	32	25	SL6062092TN	6	7	SM6063002TN	22	42
SL6040892TN	2	16	SL6062092TN	16	8	SM6066052TP	42	51
SL6040892TN	6	48	SL6062092TN	18	13	SM6083002TN	24	51
SL6040892TN	8	48	SL6062592TN	14	22	SM6083002TP	10	5
SL6040892TN	14	16	SL6063042TN	34	67	SM8040402TP	12	51
SL6040892TN	30	37	SL6063092TN	14	20	SM8040402TP	32	9
SL6040892TN	32	35	SL9061693SE	2	22	SM8040602TP	32	27
SL6040892TN	42	59	SL9061693SE	10	13	SM8041012TP	10	44
SL6041042TN	22	5	SL9082093SE	46	55	SM8050602TP	26	20
SL6041092TN	2	28	SM0030601SA	6	16	SM8050812TP	8	51
SL6041092TN	6	32	SM0040601SA	2	46	SM8050812TP	12	50
SL6041092TN	22	17	SM0040601SA	6	21	SM8050812TP	22	46
SL6041092TN	26	31	SM0040601SA	12	53	SM8050812TP	32	3
SL6041092TN	30	22	SM0040601SA	22	20	SM8060612TP	40	7
SL6041092TN	32	50	SM0041001SC	26	2	SM8060802TP	16	23
SL6041092TN	34	50	SM1030801SC	6	37	SM8062012TP	14	25
SL6041292TN	14	23	SM1030801SC	34	60	SM9052003SC	30	15
SL6041292TN	30	21	SM1043001SP	40	12	SM9082503SE	10	2
SL6041642TN	26	42	SM1062052TP	2	40	SM9082503SE	18	15



NUMERICAL INDEX OF PARTS

PART NO	PAGE	REF NO.	PART NO	PAGE	REF NO.
SS4110515SP	40	44	WS0310002KN	34	48
SS6060210SP	62	4	WS0410002KN	10	26
SS6121212TP	14	9	WS0410002KN	32	40
SS7090520SP	40	25	WS0510002KN	6	34
SS8660612TP	14	7	WS0510002KN	16	18
SS8660612TP	18	5	WS0510002KN	58	16
SS8660612TP	22	28	WS0610002KN	2	41
TA0550604R0	48	15	WS0820002KN	2	33
TA0800504R0	42	56	WS0820002KN	22	38
WP0320501SC	6	39	WS0820002KN	46	58
WP0320501SC	34	61	WS1643202KR	58	20
WP0320501SC	38	51			
WP0430800SC	26	35			
WP0430800SC	30	26			
WP0430801SC	10	54			
WP0430801SC	12	54			
WP0430801SC	22	14			
WP0430801SC	26	6			
WP0430801SC	30	43			
WP0430801SC	32	54			
WP0430801SC	34	54			
WP0430801SE	40	31			
WP0451016SP	24	52			
WP0531000SF	40	36			
WP0531001SC	6	35			
WP0531001SC	16	19			
WP0531001SC	38	48			
WP0621016SH	26	38			
WP0621016SH	30	29			
WP0621016SH	42	52			
WP0641601SC	2	42			
WP0641601SC	22	43			
WP0641601SC	30	19			
WP0641601SC	36	23			
WP0651646SC	18	38			
WP0651646SC	32	37			
WP0841601SC	4	53			
WP0841601SC	10	3			
WP0841601SC	18	35			
WP0841601SC	22	39			
WP0841601SC	46	56			
WP0852086SC	2	32			
WP1612616SE	58	19			
WS0310002KN	6	38			
WS0310002KN	10	24			