

锂离子电池规格书

Specification For Lithium-ion Rechargeable Cell

电芯型号 : ESS 72173207-305A

Cell Type : ESS 72173207-305A

Document No		Version change date	2021-03-28
Version	1.0	Pages	16
Customer	Approved	Checked	Designed
			Jerry Yang

Contents 目录

Contents 目录.....	1
1. Preface 前言.....	2
2. Norms and Standard 标准.....	2
3. Definition 定义.....	2
3.1 Room Temperature 室温.....	2
3.2 Rated capacity 额定容量.....	2
3.3 Charge Rate 充电倍率.....	2
3.4 Cycle life 循环寿命.....	2
3.5 Open circuit voltage (OCV) 开路电压.....	3
3.6 Operating Voltage 工作电压.....	3
3.7 Standard charge method 标准充电.....	3
3.8 Standard discharge method 标准放电.....	3
3.9 Rapid discharge method 快速放电.....	3
3.10 Restore capacity 可恢复容量.....	3
3.11 Charge retention 荷电保持能力.....	3
3.12 Capacity recovery capability 容量恢复能力.....	4
3.13 State of charge (SOC) 荷电状态.....	4
3.14 Units of measurement 测量单位.....	4
4. Cell type and size 电池型号及尺寸.....	5
4.1 Description and model 电池说明及型号.....	5
4.2 Cell size 电池尺寸.....	5
5. Product Performance 产品性能.....	5
5.1 Technical Parameters 技术参数.....	5
5.2 充电模式 Charging Model.....	6
5.3 不同温度下充电电流限制 Charging Current Limit at Different Temperature.....	7
5.4 Maximum pulse charging current allowed 允许最大脉冲充电电流.....	7
5.5 Discharging Model 放电模式.....	8
5.6 OCV 开路电压.....	10
5.7 Safety Characteristics 安全性能.....	10
5.8 Storage Performance 储存性能.....	12
6. Precautions for Transportation 运输注意事项.....	12
7. Warranty 质量保证.....	13
8. Storage and Shipment Requirement 存储及运输要求.....	13
9. Warning and cautions in handling the lithium-ion cell 电池使用时警告事项及注意事项.....	13
10. Emergency Treatment 紧急情况处理.....	16
11. The restriction of the use of hazardous substances 有害物质控制要求.....	16
12. Contact information 联系方式.....	16

1. Preface 前言

This specification describes the type and size, performance, technical characteristics, warning and caution of the lithium ion rechargeable cell. The specification only applies to ESS 72173207-305A prismatic cell supplied by Envision AESC.

本标准描述了方形锂离子电池的外型尺寸、特性、技术要求及注意事项。本标准适用于远景 AESC 生产的方形 ESS 72173207-305A 锂离子电池。

2. Norms and Standard 标准

The cells must be fulfilled the following Norms and Standard:

No.	Standard name	Remark
N1	GB/T 36276	Lithium ion battery for electrical energy storage

3. Definition 定义

3.1 Room Temperature 室温:25±2°C

3.2 Rated capacity 额定容量:

Rated capacity: Cap=305Ah.Under 25±2°C, It means the capacity value of being discharged by 2-hours rate to end voltage 2.5 V, which is signed Cap, the unit is Ah.

额定容量 Cap=305Ah, 指在 25±2°C 环境下, 以 2 小时率放电至终止电压 2.5 V 时的容量, 以 Cap 表示, 单位为安培时(Ah)。

3.3 Charge Rate 充电倍率

The current value that the battery need to discharge its rated capacity in a stated time, which equal to a multiple of the rated capacity of the battery on the data value, usually expressed with the letter “C”.

电池在规定的时间内放出其额定容量时所需要的电流值, 它在数据值上等于电池额定容量的倍数, 通常以字母 C 表示。

3.4 Cycle life 循环寿命

With the repeated charging and discharging, the battery's capacity will gradually decline. Usually the rated capacity of the battery is a standard, the number of charge-discharge cycles a battery can go through before it reaches 70% of its rated capacity called cycle life.

二次电池在反复充放电的使用下, 电池的容量会逐渐下降, 通常以该电池的额定容量作为标准, 电池容量降到其 70% 的充放电次数, 称为循环寿命。

3.5 Open circuit voltage (OCV) 开路电压

Open-circuit voltage is the difference of electrical potential between two tabs of a device when disconnected from any circuit.

开路电压是指外电路没有电流流过时电池正负极耳之间的电位差。

3.6 Operating Voltage 工作电压

Operating voltage, also known as the discharge voltage or load voltage, is defined as the potential difference between the battery terminals when the current transmits through the external circuit. Working voltage is always lower than the open circuit voltage, because when the current transmits through the battery internal, the polarization resistance and ohmic resistance must be overcome.

工作电压又称放电电压或负荷电压，是指有电流通过外电路时，电池两极间的电位差。工作电压总是低于开路电压，因为电流流过电池内部时，必须克服极化电阻和欧姆内阻所造成的阻力。

3.7 Standard charge method 标准充电

Under $25\pm 2^{\circ}\text{C}$, it can be charged to 3.65V with constant current of 0.5C, and then, charged continuously with constant voltage of 3.65 V until the charged current is 0.05C.

指在 $25\pm 2^{\circ}\text{C}$ 环境下，以 0.5C 的电流恒流充电至单体电池电压 3.65V 后，转为恒压 3.65V 充电，至充电电流小于 0.05C 时，停止充电。

3.8 Standard discharge method 标准放电

At $25\pm 2^{\circ}\text{C}$, it can be discharged to the voltage of 2.5 V with constant current of 0.5C.

指在 $25\pm 2^{\circ}\text{C}$ 环境下，以 0.5C 的电流恒流放电至单体电池的终止电压 2.5V。

3.9 Rapid discharge method 快速放电

At $25\pm 2^{\circ}\text{C}$, it can be discharged to the voltage of 2.5 V with constant current of 1C.

指在 $25\pm 2^{\circ}\text{C}$ 环境下，以 1C 的电流恒流放电至单体电池的终止电压 2.5 V。

3.10 Restore capacity 可恢复容量

After storage, the capacity tested according to the standard charge and discharge conditions listed in section 3.7 and 3.9, the maximum of 3 measured values were selected as restore capacity.

电池储存后，按照本规格书第 3.7 和 3.9 条所列的标准充放电条件所测得的容量，取值分别按照本规格书第 3.7 和 3.9 条给出的充放电标准，分别选取 3 次测量的最大值。

3.11 Charge retention 荷电保持能力

The percentage of the discharge capacity and rated capacity after the battery stored in a certain temperature and time condition.

电池在一定温度下，储存一定时间后，放电所获得的容量与额定容量之比的百分数。

3.12 Capacity recovery capability 容量恢复能力

The percentage of the discharge capacity and rated capacity with recharging after the battery stored in a certain temperature and time.

电池在一定温度下，储存一定时间后再行充电，其后放电容量与额定容量之比的百分数。

3.13 State of charge (SOC) 荷电状态

The percentage of remaining energy. Only with estimating the battery SOC accurately can improve the utilization efficiency of the battery, and ensure the battery life and safety.

电池剩余电量百分比，电池一个重要的参数，只有准确估算电池 SOC 才能有效提高电池利用效率、保证电池的使用寿命和安全。

3.14 Units of measurement 测量单位

① “V” (Volt), Unit of voltage

“V” (Volt) 伏特，电压单位

② “A” (Ampere), Unit of current

“A” (Ampere) 安培，电流单位

③ “Ah” (Ampere-Hour), Unit of electric charge

“Ah” (Ampere-Hour) 安培-小时，电荷单位

④ “Wh” (Watt-Hour), Unit of energy

“Wh” (Watt-Hour) 瓦特-小时，能量单位

⑤ “mΩ” (MilliOhm), Unit of resistance

“mΩ” (MilliOhm) 毫欧姆，电阻单位

⑥ “°C” (degree Celsius), Unit of temperature

“°C” (degree Celsius) 摄氏度，温度单位

⑦ “mm” (millimeter), Unit of length

“mm” (millimeter) 毫米，长度单位

⑧ “s” (second), Unit of time

“s” (second) 秒，时间单位

⑨ “Hz” (Hertz), Unit of frequency

“Hz” (Hertz) 赫兹，频率单位

4. Cell type and size 电池型号及尺寸

4.1 Description and model 电池说明及型号

Description: Prismatic Li-ion rechargeable cell

Model: ESS 72173207-305A

ESS 72173207-305A 型号方形锂离子二次电池

4.2 Cell size 电池尺寸

Cell physical dimension listed in following figure(unit: mm).

电池尺寸图如下图所示（单位：mm）。

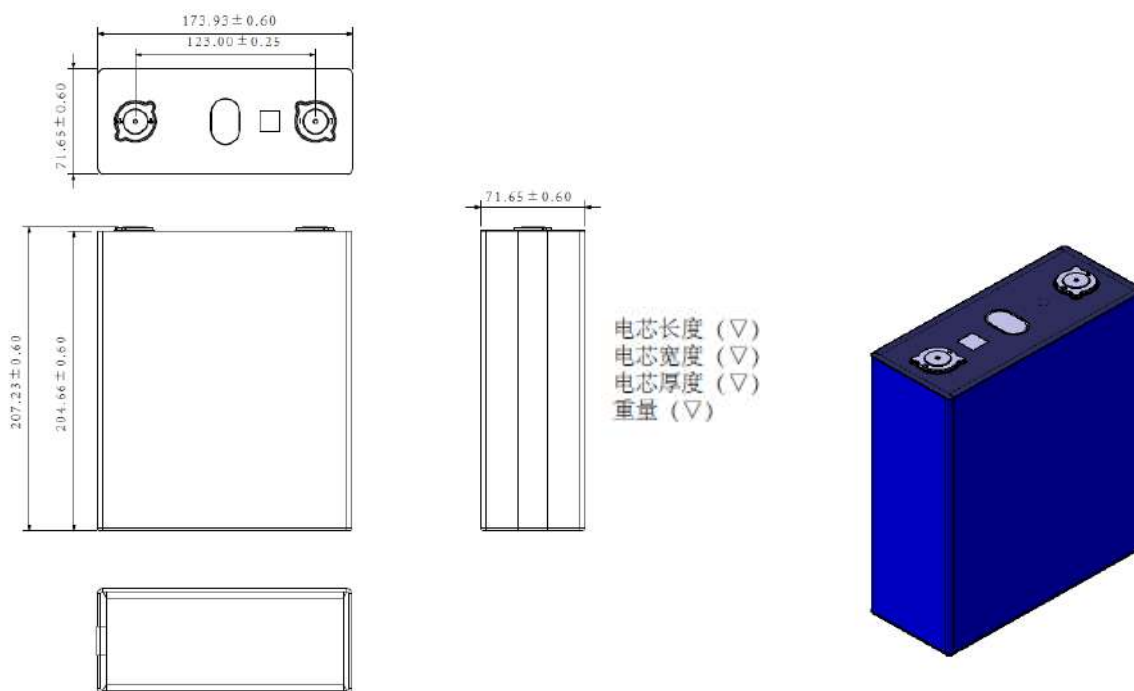

5. Product Performance 产品性能

Fresh cell, tested at $25 \pm 2^\circ\text{C}$, standard charge and discharge unless otherwise specified

电池特性（除非有特殊说明，否则所有测试要求为：温度在 $25 \pm 2^\circ\text{C}$ 条件下，样品为新电池，充放电制度为标准充电和标准放电）

5.1 Technical Parameters 技术参数

ITEM 项目	SPECIFICATION 特性
Nominal Capacity 额定容量	305.0Ah@0.5C
Nominal voltage	3.2V

额定电压	
Charge voltage (End current) 充电电压 (截止电流)	3.65V
Discharge ending voltage 放电终止电压	2.5V
Nominal energy 额定能量	976Wh@0.5C
Max continuous discharge current 最大持续放电电流	153A
Max. peak discharge current 最大脉冲放电电流	610A@30S
Max.continuous charge current 最大持续充电电流	153A
Charge temperature range 充电温度窗口	0~60°C
Discharge temperature range 放电温度窗口	-30~60°C
Storage temperature 存储温度	-30~60°C
Internal resistance 内阻	≤ 0.3 mΩ(AC Impedance, 1000 Hz)
Cycle life 循环	≥5000cycles (standard charge and standard discharge)
Recommended SOC Window推荐 SOC使用窗口	SOC: 0%~100%
Cell size 电芯尺寸	Thickness: 71.65±0.60 mm 厚度: 71.65±0.60mm (含蓝膜) Width: 173.93±0.60mm 宽度: 173.93±0.60mm (含蓝膜) Height: 207.23±0.6mm 高度: 207.23±0.6mm (含极柱、底盖)
Weight 重量	5.545±0.050kg

5.2 充电模式 Charging Model

序号 NO.	参数 Parameter	规格 Values	备注 Remarks
5.2.1	标准充电模式 Standard Charging Model	the standard charge model according to the conditions listed in section 3.7 同3.7测试标准	
5.2.2	标准充电温度 Standard	25±2°C	电池温度 Cell Temperature

	Charging Temperature		
5.2.3	绝对充电温度 Absolute Charging Temperature	0~60℃	No matter what the charging model is, once the temperature of the cell is above the absolute charging temperature, charging should be stopped. 无论电池处在何种充电模式，一旦发现电池温度超过绝对充电温度范围，即停止充电
5.2.4	绝对充电电压 Absolute Charging Voltage	最大3.65V Maximum 3.65V	No matter what the charging model is, including pulse charging, once the voltage of the cell is above the absolute charging voltage, charging should be stopped. 无论电池处在何种充电模式包括脉冲充电状态，一旦发现电池电压超过绝对充电电压范围，即停止充电

5.3 不同温度下充电电流限制 Charging Current Limit at Different Temperature

Cell temperature range 电池温度范围	<0℃	0-10℃	10-20℃	20-30℃	20-30℃	>60℃
Maximum charging current allowed 最大充电电流	小电流运行 (需与电芯供应商)	0.1C	0.2C	0.5C	0.5C	小电流运行 (需与电芯供应商)

5.4 Maximum pulse charging current allowed 允许最大脉冲充电电流

During the process of product being used, pulse current created in regenerative braking can recharge the battery. Maximum charging current allowed and the pulse duration in different temperature conditions must strictly observe the conditions listed in the following table. Violating the described conditions may cause permanent damage to the battery and thus is exempt from the responsibility of Envision AESC for product quality.

产品使用过程中，再生制动过程的脉冲电流对电池具有充电效果。不同温度条件下的允许最大脉冲充电电流和持续时间必须严格遵守下表所列的所有充电状态以及电池温度等条件。违反下列充电条件可能会造成电池永久性的损坏并进而免除远景 AESC 的产品质量责任。

In different SOC and temperature conditions, the maximum values of charging current allowed and the pulse duration are shown in the following table:

不同 SOC 和温度条件下，允许最大脉冲充电电流和持续时间如下表所示：

SOC	电池温度 Cell Temperature
-----	--------------------------

	≤-5℃	-5~0℃	0~10℃	10~23℃	23~50℃
>90%	不允许 Not allowed	不允许 Not allowed	不允许 Not allowed	1C/5s	1C/10s
>80%	不允许 Not allowed	不允许 Not allowed	1C/5s	1.5C/10s	2C/10s
>70%	不允许 Not allowed	0.5C/5s	1C/10s	2C/10s	2C/10s
<70%	不允许 Not allowed	0.5C/10s	1.5C/10s	2C/10s	2C/10s

After each brake charging, the battery needs to rest for certain time, which should be equal to or longer than the duration of the pulse charging. During the rest, the battery can be in the discharged state, or in a non-working state. But in the rest period, the battery is not allowed to pulse recharge again.

每次制动充电后，电池需要有段休眠时期，时间应等于或长于脉冲充电持续时间。休眠时期内，电池可以处于放电状态，也可以处于零电流不工作状态，但在休眠时期内，不允许电池再次发生制动充电现象。

5.5 Discharging Model 放电模式

①测试条件 Test Conditions

Unless otherwise specified, all the experiments should be carried out under ambient temperature: 25±5℃, relative humidity: 25%~85% and atmospheric pressure: 86KPa~106KPa.

除另有规定外，试验应在温度为：25±5℃，相对湿度为：25%~85%，大气压力为：86KPa~106KPa 的环境中进行。

②Requirements of Measuring Instruments and Facilities 测量仪表与设备要求

All of the measuring instruments and facilities (include the equipments which monitor the test parameters) should be verified and calibrated qualified by relevant Chinese Calibration Regulation or certain standards within the valid date. All the test instruments and equipments should have adequate precision and stability and the precision should be an order higher than the tested indicators or the tolerance should be less than one third of the tested parameters.

检验测试的所有仪表、设备（包括监控和监视试验参数的试验设备和仪器）应按国家有关计量检定规程或有关标准经检定或计量合格，并在有效期内。所有测试仪表、设备应具有足够的精度和稳定度，其精度应高于被测指标精度一个数量级或误差小于被测参数允许误差的三分之一。

NO. 序号	Items 项目	Technical Requirements 技术要求	Test Methods 测试方法及步骤
-----------	-------------	--------------------------------	-------------------------

1	Appearance 外观	电池应无破损、漏液、油污等缺陷，标识清楚。 No damage, leakage, oil contamination. Legibly marked.	目测法 Visual Inspection
2	Discharging performance under room temperature 室温放电性能	放电容量/额定容量×100%： Discharging Capacity/Nominal Capacity×100%： a) 153A 放电时≥100% Discharged at 153A ≥100% b) 305A 放电时≥95% Discharged at 305A ≥95%	It's the capacity (in Ah) when batteries are discharged to 2.5V with 153A (305A) at 25±2°C. 室温下，以 153A (305A) 进行放电至下限电压 2.5V，计算放电容量（以 Ah 计）。
3	高低温放电性能 Discharging characteristics under high and low temperatures	放电容量/额定容量×100%： Discharging Capacity/Nominal Capacity×100%： a) 60°C时≥98% Discharged at 60°C ≥98% b) -20°C时≥70% Discharged at -20°C ≥70%	高温放电容量： High-temperature discharge capacity: a) Standard charge 电池标准充电； b) Be set aside for 5h at 60±2°C； 在60±2°C条件下搁置5h； c) Discharging the battery to 2.5V with 153A at 60±2°C, calculate the capacity. 在60±2°C条件下以153A放电至终止电压2.5V，计算放电容量（以Ah计）。 低温放电容量试验按如下步骤进行： Low-temperature discharge capacity test: a) Standard charge 电池标准充电； b) Be set aside for 24h at -20±2°C； 在-20±2°C条件下搁置24h； c) Discharging the battery to 2.0V with 153A at -20±2°C, calculate the capacity在-20±2°C条件下以153A放电至终止电压2.0V，计算放电容量（以Ah计）。
4	常温荷电保持与容量恢复能力 Charge retention and capacity recoverable	荷电保持率≥98% Charge retention ≥98% 容量恢复率≥99% Capacity recovery ≥99%	a) Standard charge 电池标准充电； b) Stored for 28 days at 20±5°C； 在20±5°C条件下储存28天； c) Under room temperature, discharge it at 153A to cut-off voltage and calculate retention capacity (in Ah). 室温下，以153A 放电至终止电压，计算荷

	capability under room temperature		<p>电保持容量（以Ah计）；</p> <p>d) Then standard charged again; 电池再进行标准充电；</p> <p>e) Under room temperature, discharge it at 153A to cut-off voltage and calculate recovery capacity (in Ah). 室温下，以153A 放电至终止电压，计算恢复容量（以Ah计）。</p>
5	循环寿命 Cycle Life	<p>≥5000次</p> <p>≥5000 cycles</p>	<p>a) At room temperature, charged to 3.65V at a constant current of 153A, and then, changed continuously with constant voltage of 3.65V until the current was not more than 15.3±0.01A. 室温下，以153A恒流持续充电至单体电池电压3.65V，然后在3.65V下恒压持续充电直至电流下限≤15.3±0.1A</p> <p>b) Discharged at 153A to the cut-off voltage at room temperature; 室温下，以153A恒流放电至终止电压；</p> <p>c) Repeating steps of a) ~ b), until the discharge capacity reached the 70% of rated capacity, the number of cycles completed was defined as the battery cycle life. 重复a)~b), 至容量衰减为额定容量的70%止，所完成的循环次数定义为该电池的循环寿命。</p>

5.6 OCV 开路电压

SOC	0%	10%	20%	30%	40%	50%	60%	70%	80%	90%	100%
OCV	2.827	3.206	3.243	3.274	3.291	3.293	3.297	3.330	3.332	3.333	3.348

5.7 Safety Characteristics 安全性能

序号 NO.	项目 Items	技术要求 Technical Requirements	测试方法及步骤 Test Methods & Steps
1	过充电 Overcharge Test	不爆炸、不起火 No explosion. No fire.	<p>a) Standard charge 电池标准充电；</p> <p>b) 以 305A 电流充电至企业规定最大截止电压的 1.5 倍或充电 1h 后停止。</p>

2	过放电 Over-discharge Test	不爆炸、不起火、不漏液 No explosion. No fire. No leakage.	a) Standard charge 电池标准充电; b) 以 305A 电流放电 90min 或电压降为 0V。 Discharged for 90min with 305A current or voltage becomes 0V.
3	短路 Short-circuit Test	不爆炸、不起火 No explosion. No fire.	a) Standard charge 电池标准充电; b) Connect the battery positive and negative terminals with wire for 10min directly. The resistance of external line should be less than 5mΩ. 将电池正、负极经外部短路 10min, 外部线路电阻应小于 5mΩ。
4	挤压 Crushing Test	不爆炸、不起火 No explosion. No fire.	a) Standard charge 电池标准充电; b) 按下列条件进行试验: According to the following test conditions: ——挤压方向: 垂直于蓄电池极板方向施压。 Crushing direction: Pressure perpendicular to the battery plates. ——挤压程度: 直至电芯电压达到 0V 或变形量达到 30% 或挤压力达到 13±0.78KN. Squeeze level: Until the cell voltage reaches 0V or the deformation reaches 30% or the extrusion force reaches 13±0.78KN
5	跌落 Drop Test	不爆炸、不起火 No explosion. No fire.	a) Standard charge 电池标准充电; b) The positive or negative terminal of the single cell is freely dropped from a height of 1.5m to the concrete floor once. 单体电芯的正极或负极端子朝下从 1.5m 高度处自由跌落到水泥地面上 1 次。
6	低气压	不爆炸、不起火、不漏液 No explosion. No fire. No leakage.	a) Standard charge 电池标准充电; b) The single cell places in a low pressure 11.6KPa environment for 6h. 单体电芯在低气压 11.6Kpa 环境中静置 6h
7	加热	不爆炸、不起火 No explosion. No fire.	a) Standard charge 电池标准充电; b) 单体电芯以 5℃/min 的速率由环境温度

			<p>升至 $130 \pm 2^{\circ}\text{C}$ 并保持 30min.</p> <p>The single cell rises from ambient temperature to $130 \pm 2^{\circ}\text{C}$ at a rate of $5^{\circ}\text{C}/\text{min}$ and keeps it for 30min.</p>
8	热失控	<p>不爆炸、不起火</p> <p>No explosion. No fire.</p>	<p>a) Standard charge 电池标准充电;</p> <p>b) 触发电芯达到热失控</p> <p>Trigger Single cells to achieve thermal runaway.</p>
<p>注：电池安全试验参考 GBT 36276-2018 《电力储能用锂离子电池》。</p> <p>Notes: Refer to GBT 36276-2018 <i>Lithium ion battery for electrical energy storage</i></p>			

5.8 Storage Performance 储存性能

NO. 序号	Parameter 参数	Specifications 产品规格	Condition 条件
1	Restorable capacity (Short term) 可恢复容量 (短期)	$\geq 98\%$	Standard charged to 30% SOC, and storage for 30 days at 25°C 标准充电到30%SOC, 25°C 温度储存30天
2	Restorable capacity (Long term) 可恢复容量 (长期)	$\geq 95\%$	Standard charged to 30% SOC, and storage for 180 days at 25°C 标准充电到30%SOC, 25°C 温度储存180天

6. Precautions for Transportation 运输注意事项

The Cell shall be shipped in capacity range of 20% ~ 30% or in accordance with customers' requirement. The remaining capacity before charging shall be changed depending on the storage time and conditions.

单体电池按 20%~40%的充电容量或客户要求出货,电池出货后充电前的剩余容量取决于储存时间和条件.

The batteries should be packed in boxes for transportation which should be conducted not less than 30% SOC. They are also should be prevented from vibration, shock, extrusion, sun-scorched and rain-drenched. It could be delivered by car, train, boat, etc. If it will be delivered by air, please refer to MH/T 1020-2013 Standards for transport of lithium batteries by air.

电池应在 $\geq 30\%$ 荷电状态下包装成箱进行运输,在运输过程中应防止剧烈振动、冲击或挤压、防止日晒雨淋,不得倒置。适用于汽车、火车、轮船等交通工具运输。航空运输请参照 MH/T 1020-2013 《锂电池航空运输规范》。

7. Warranty 质量保证

The Warranty period of cell is made according to business contract. However, even though the problem occurs within this period, AESC won't replace a new cell for free as long as the problem is not due to the failure of AESC manufacturing process or is due to customer's abuse or misuse.

自出货之日起,电池的保质期限依合同而定.但是,在此期限内,如果非 AESC 的制程原因。而是客户的误用造成的电池质量问题,AESC 不承诺免费更换.

AESC will not be responsible for trouble occurred by handling outside of the precautions in instructions.

AESC 对违反安全守则操作所产生的问题不承担任何责任.

AESC will not be responsible for trouble occurred by matching electric circuit, cell pack and charger.

AESC 对与电路,电池组,充电器搭配使用所产生的问题不承担任何责任.

AESC will be exempt from warrantee any defect cells during assembling after acceptance.

出货后客户在电池组装过程中产生的不良电池不在 AESC 质量保证的范围之列.

8. Storage and Shipment Requirement 存储及运输要求

Item 项目	Requirement 要求
储存 Storage environment	Short period less than 1 month 短期少于 1 个月 -30°C ~ +55°C, 90%RH Max
	Long period more than 3 month 长期超过 3 个月 -10°C ~ + 45°C, 90%RH Max
	Recommend storage 推荐存储 -10°C ~ + 25°C , 85%RH Max
长时间存储: 如果电芯长时间存储, 电芯 SOC 状态不应低于 5%。且每 6 个月进行一次充放电。 Long time storage :If the cell is stored for a long time, the SOC state of the battery cell should not be less than 5%. Also, it is recommended to charge the cell every six months.	

9. Warning and cautions in handling the lithium-ion cell 电池使用时警告事项及注意事项

Lithium-Ion rechargeable batteries subject to abusive conditions can cause damage to the cell and/or personal injury. Please read and observe the standard cell precautions below before using utilization.

滥用锂离子充电电池可能会造成电池的损害或人身的伤害.在使用锂离子充电电池以前,请仔细阅读以

下的安全守则：

Note 1. The customer is required to contact AESC in advance, if and when the customer needs other applications or operating conditions than those described in this document.

注释 1. 如果客户需要其它应用程序或本档中描述之外的操作条件，客户需要提前联系 AESC。

Note 2. AESC will take no responsibility for any accident when the cell is used under other conditions than those described in this Document.

注释 2. 在该文件说明的条件之外使用该电池而产生的事故，AESC 不承担任何责任。

Warning! 警告

Danger warning (it should be described in manual or instruction for users, indicated especially) to prevent the possibility of the battery from leaking, heating, explosion. Please observe the following precautions:

危险警告：（应在使用说明手册或说明书中，特别注明）为防止电池可能发生泄漏，发热，爆炸，请注意以下预防措施：

Don't immerse the battery in water and seawater. Please put it in cool and dry environment if no using.

严禁将电池浸入海水或水中，保存不用时，应放置在阴凉干燥的环境中。

Don't use and leave the cell near a heat source such as fire or heater.

禁止将电池在热高温源旁，如火，加热器等旁边使用和留置。

Do not use or leave the cell under the blazing sun (or in heated car by sunshine).

不要将电池放置在太阳光直射的地方。

Being charged, using the battery charger specifically for that purpose.

充电时请选用锂离子电池专用充电器。

Don't reverse the positive and negative terminals

严禁颠倒正负极后使用电池。

Do not disassemble or modify the cell.

不要拆卸或修整电池。

Do not use the cell with conspicuous damage or deformation..

不要使电池受到明显的损害或变形。

Don't connect the cell to an electrical outlet directly.

严禁将电池直接插入电源插座。

Don't discard the cell in fire or heater.

禁止将电池丢入火或加热器中。

Do not short circuit, over-charge or over-discharge the cell.

不要将电池短路,过充或过放。

Don't transport and store the cell together with metal objects such as necklaces, hairpins.

禁止将电池与金属,如发卡、项链等一起运输或存储。

Do not use lithium ion battery and others different lithium battery model in mixture.

禁止与液态锂离子或不同型号的锂电池混合使用。

Keep the battery away from babies.

电池应远离小孩。

Don't strike, throw or trample the cell.

禁止敲击,抛掷或踩踏电芯等。

Prohibition of use of damaged cells.

禁止使用已损坏的电池。

Battery pack designing and packing Prohibition injury batteries.

电池外壳设计和包装禁止损伤电池。

The battery replacement shall be done only by either cells supplier or device supplier and never be done by the user.

更换电池应由电池供应商或设备供应商完成,用户不得自行更换。

Be aware discharged batteries may cause fire; tape the terminals to insulate them..

废弃之电池应用绝缘纸包住电极,以防起火,爆炸。

Do not use it in a location where is electrostatic and magnetic greatly, otherwise, the safety devices may be damaged, causing hidden trouble of safety.

禁止在强静电和强磁场的地方使用,否则易破坏电池安全保护装置,带来不安全的隐患。

Do not directly solder the battery and pierce the battery with a nail or other sharp object.

禁止直接焊接电池和用钉子或其它利器刺穿电池。

When disposing of secondary cells, keep cells of different electrochemical systems separate from each other.

二次电池处理时,请将电池和其他电化学体系的产品分开。

Cautions! 小心

Don't use or leave the cell at very high temperature conditions (for example, strong direct sunlight or a vehicle in extremely hot conditions).

禁止在高温下（直热的阳光下或很热的汽车中）使用或放置电池，否则可能会引起电池过热，起火或功能失效，寿命减短。

10. Emergency Treatment 紧急情况处理

If the cell leaks and the electrolyte get into your eyes, don't wipe eyes, instead, thoroughly rinse the eyes with clean running water for at least 15 minutes, and immediately seek medical attention. Otherwise, eyes injury can result.

如果电池发生泄露，电解液进入眼睛，请不要搓揉，应用清水冲洗眼睛，必要时请立即前往医院接受治疗，否则会伤害眼睛。

If the cell gives off an odor, generates heat, becomes discolored or deformed, or in any way appear abnormal during usage, recharging or storage, immediately remove it from the device or cell charger and stop using it.

如果电池发出异味，发热，变色，变形或使用、存储、充电过程中出现任何异常现象，立即将电池从装置或充电器中移开并停用。

In case the cell terminals get dirty, clean the terminals with a dry cloth before use.

如果电池弄脏，使用前应用干布抹净。

11. The restriction of the use of hazardous substances 有害物质控制要求

This model of lithium-ion cell is in accordance with our company's request of "The hazardous substances and material management standard" or customer's requirements.

本型号锂离子电池符合本公司《有害物质与材料管理规范》要求或参照客户要求执行！

12. Contact information 联系方式

If you have any questions regarding the cell, please contact the following address:

如有疑问，请按以下地址联系：

Headquarter: 8/F, Building B, SOHO Zhongshan Plaza, 1065 West Zhongsan Rd. Changning District, Shanghai China, 200051

厂址：上海市长宁区中山西路 1065 号 SOHO 中山广场 B 座 8 楼

Tel : +86-21-6031 8000

电话： +86-21-6031 8000