

Reverse Roll Shades

'Reverse roll' refers to changing the fabric on the roll so the fabric falls from the FRONT of the roller, instead of the back of the roller ('Standard roll'). This provides additional clearance so the fabric does not interfere with obstructions, such as door or window hardware. This process is considered easy and requires no special tools. A new user will need 10 minutes to complete this process.

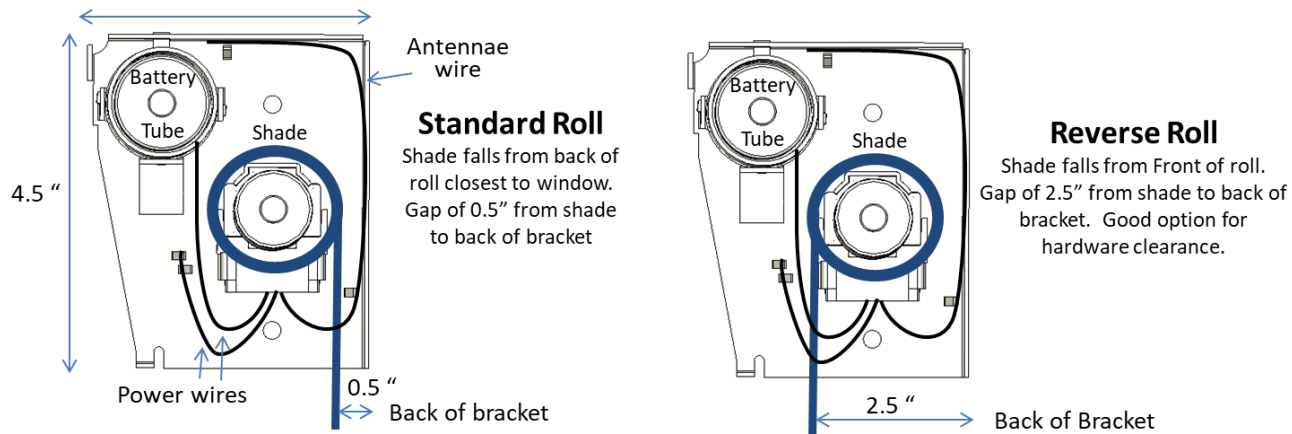

PROCESS for reverse rolling a shade:

1. Clear a flat space to roll the shade out – counter or floor. Ensure the space is clean so the shade is not soiled during the rolling process.
2. Roll out the shade all the way to the roller end. The shade is attached to the roller with tape.
3. Carefully, pull the fabric away from the roller, ensuring that the fabric does not stretch. Tape will remain on the roller tube.
4. When the fabric is off the tube, place the tube on the opposite side of the fabric. If the fabric was on top of the tube, place the tube on top of the fabric, and vice versa.
5. Line the fabric up on one side corner with the tape, and one of the embossed lines of the tube. Use that line to carefully guide the fabric and press so the edge is along the line.
6. After the fabric is attached to the tube, roll the tube up.
7. The fabric should roll up evenly on the tube. If the fabric travels significantly left or right (more than $\frac{1}{4}$ "), unroll the fabric and realign the fabric on the tube.

Reassemble the tube on the brackets.

If the fabric continues to travel left or right, please refer to instructions for correcting "Telescoping" at the bottom of the FAQ section.