

US
WG
no. 1-413

TM 1-413

WAR DEPARTMENT

TECHNICAL MANUAL

AIRCRAFT INSTRUMENTS

February 2, 1942

CHRYSLER CORPORATION
ENGINEERING LIBRARY
DETROIT, MICH.

DISTRIBUTION STATEMENT A
Approved for Public Release
Distribution Unlimited

Reproduced From
Best Available Copy

20000518 146

US W 8

*TM 1-413

TECHNICAL MANUAL }
No. 1-413 }

WAR DEPARTMENT,
WASHINGTON, February 2, 1942.

AIRCRAFT INSTRUMENTS

Prepared under direction of the
Chief of the Air Corps

	Paragraphs
SECTION I. General.....	1-2
II. Maintenance, storage, and repair.....	3-7
III. Installation.....	8-10
IV. Fuel pressure gages.....	11-15
V. Suction gages.....	16-20
VI. Manifold pressure gages.....	21-25
VII. De-icing pressure gages.....	26-30
VIII. Oil pressure gage.....	31-35
IX. Landing gear pressure gage.....	36-40
X. Engine gage units.....	41-45
XI. Chronometric tachometers.....	46-50
XII. Generator-voltmeter tachometers.....	51-55
XIII. Engine synchronism indicator (Weston).....	56-60
XIV. Engine synchroscope (Eclipse).....	61-65
XV. Vapor pressure thermometers.....	66-70
XVI. Electrically operated thermometers.....	71-75
XVII. Cylinder temperature gages.....	76-80
XVIII. Fuel mixture indicators.....	81-85
XIX. Self-synchronous instruments.....	86-90
XX. Selsyn instruments.....	91-95
XXI. Fuel level gages.....	96-100
XXII. Aircraft compasses (magnetic).....	101-105
XXIII. Air speed indicators.....	106-110
XXIV. Air speed tubes.....	111-115
XXV. Altimeters.....	116-120
XXVI. Rate of climb indicators.....	121-125
XXVII. Bank and turn indicators.....	126-130
XXVIII. Turn indicators (directional gyro).....	131-135
XXIX. Flight indicators.....	136-140
XXX. Automatic pilot type, A-2.....	141-145
XXXI. Miscellaneous instruments.....	146-148
XXXII. Type C-1 portable instrument field test set.....	149-154
XXXIII. Instrument test equipment.....	155-170
INDEX.....	Page 229

*This manual supersedes TM 1-413, November 7, 1940.

SECTION I

GENERAL

Paragraph

General 1
 Design characteristics 2

1. **General.**—*a.* Safe, economical, and reliable operation of modern aircraft and their power plants is absolutely dependent upon the use of instruments. Due to the inability of the human senses to cope with the many and variable climatic conditions and the complicated mechanical devices, it is essential that certain physical quantities be measured and indicated. These measured indications must be extremely accurate and readily accessible to the flight crew of the aircraft.

b. Figure 1 shows schematically the pilot's cockpit of a conventional two-engine bomber or transport airplane. There are about 105 instruments and controls for fuel, radio, landing gear, flaps, and engines. Approximately one-half of these are instruments. They must do for the airplane something of what the brain and nerves do for the human body. The crew chief is not only responsible for the proper inspection and maintenance of these instruments, but he must learn to use them for intelligent diagnosis of troubles.

2. **Design characteristics.**—The following general points are considered in the design of modern aircraft instruments:

a. Temperature compensation.—Aircraft instruments must operate and function satisfactorily through temperatures ranging from -35° C. to $+60^{\circ}$ C. Normal temperature is considered $+15^{\circ}$ C.

b. Vibration.—Aircraft instruments must function satisfactorily under vibration. Since this may be excessive at certain times, all instruments are mounted on shockproof panels which minimize the amplitude and frequencies of vibration to which the instrument is subjected. However, standard methods of shockproofing in use do not eliminate all vibration; consequently the instruments are designed to function accurately only when subjected to some vibration.

c. Sealing.—All aircraft instruments are sealed in either of two ways. The more rugged of the differential pressure-operated instruments have raintight seals. This kind of seal prevents dust and moisture from entering the instrument case. Instruments of this type are easily recognized by the presence of a small hole located in the bottom of the instrument case. Sensitive differential pressure gages, absolute pressure gages, and gyro actuated instruments require

airtight seals. It is very important that the seal be maintained on each instrument after its installation in an airplane.

d. Position.—Mechanisms of all aircraft instruments must be either balanced or restrained in such a manner that the indication will not be affected by any degree of incline from normal position up to 180° in any direction.

e. Damping.—All aircraft instruments must operate correctly or within very close limits regardless of surging acceleration and centrifugal forces. Where necessary, suitable restrainers, restrictions, or other damping devices are used.

f. Range.—All aircraft instruments have a range suitable for the function to be measured; normally the calibrated range is from 50 to 100 percent more than that ordinarily required.

g. Luminous markings.—Numerals, dial graduations, and pointers of aircraft instruments are coated with luminous paint. This paint is a radium-treated composition which makes reading possible in the dark without the aid of artificial light. This composition is highly poisonous and its application or reapplication is accomplished only at authorized repair depots.

h. Lighting.—Some standard instruments are provided with a built-in receptacle, molded integral with the instrument case, to receive a 3-volt lamp. A reflector ring is located under the cover glass so that the light is distributed evenly around the dial surface. Intensity of the light can be varied by rheostats located on the instrument panel. To use the standard 12- to 24-volt battery-generator system of the airplane as a source of current, it is necessary to use resistors placed in series with the lamps. Provision is made in all airplanes for carrying spare lamps and resistors. For each ten instruments or fraction thereof installed on the airplane, there is one spare lamp and resistor. Some later type instruments still under development do not have the built-in individual lamp; instead, the dial markings and pointers are designed and treated for reactance to fluorescent lighting which is obtained from one or two cockpit flood lamps of this kind.

i. Instrument cases.—(1) Most instrument cases are made of molded phenolic composition, the newer ones being of two-piece construction consisting of the main body and the cover glass hold-down ring. Gaskets are used to make the seal between the main body and the cover glass. Machine screws are used to fasten the cover glass hold-down ring to the case body. Threaded brass inserts are molded integral with the instrument case for receiving pipe and tube nipples which are used to attach the instrument to its operating units. The lamp receptacle is located in the upper right-hand corner at the

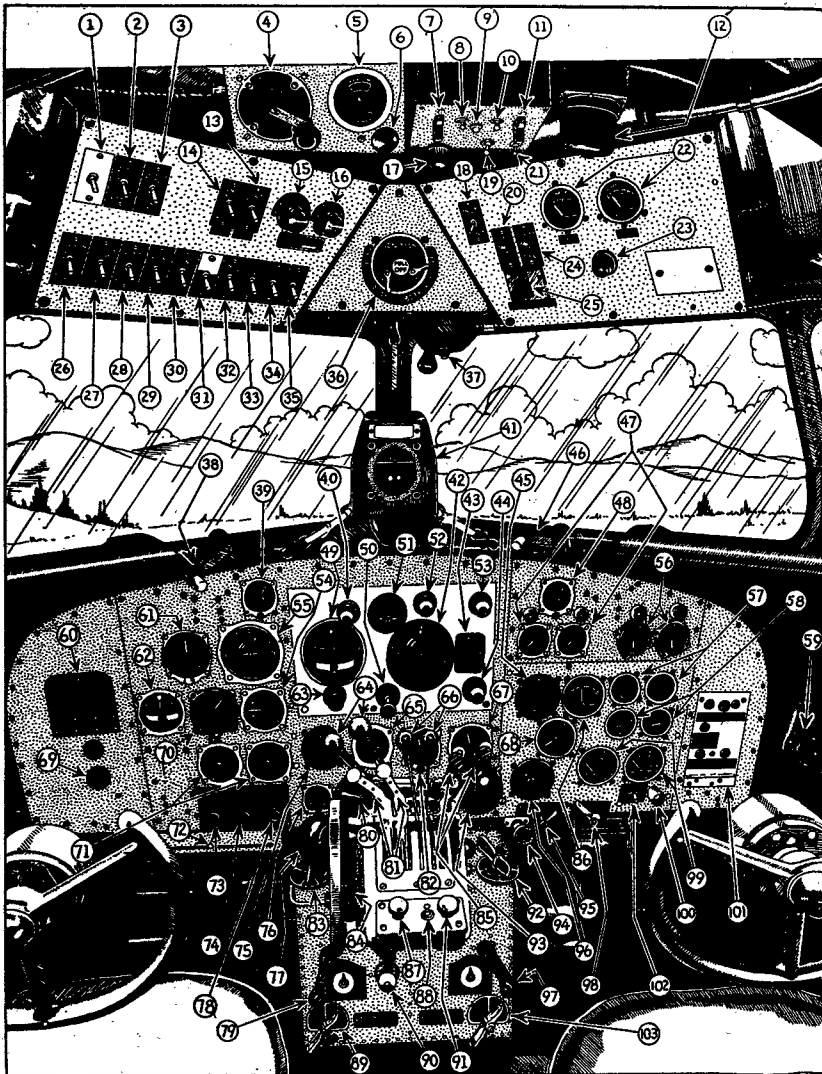

FIGURE 1.—Typical control cockpit in a two-engine transport airplane.

- | | |
|---|---|
| 1. Cabin "fasten seat belt" switch. | 10. Airport and beacon receiver change over switch. |
| 2. Propeller de-icer switch. | 11. Receiver switch. |
| 3. Carburetor de-icer switch. | 12. Electric panel light. |
| 4. Day and night frequency shift. | 13 and 14. Landing lights. |
| 5. Auxiliary receiver. | 15. Compass and gyro light rheostat. |
| 6. Auxiliary receiver tuning knob. | 16. Instrument panel light rheostat. |
| 7. Transmitter filament switch. | 17. Airline receiver volume control. |
| 8. Local distance cutting signal volume switch. | 18. Electrical instrument control switch. |
| 9. Frequency shift warning light. | 19. Dial light for auxiliary receiver. |

- | | |
|--|---|
| 20. Starter switch. | 63. Gyro caging knob. |
| 21. Auxilliary receiver power switch. | 64. Propeller pitch controls. |
| 22. Volt ammeters. | 65. Manifold pressure gage. |
| 23. Lighter. | 66. Throttles. |
| 24. Booster switch. | 67. Air speed indicator. |
| 25. Starter selection switch. | 68. Gasoline quantity gage. |
| 26. Cabin side lights switch. | 69. Cambridge indicator current adjustment. |
| 27. Cabin dome light switch. | 70. Air speed indicator. |
| 28. Pitot tube heater switch. | 71. Tachometers. |
| 29. Warning light switch. | 72. Flaps position indicator. |
| 30. Running lights. | 73. Gyro pilot rudder speed control. |
| 31. Argonne spotlights. | 74. Gyro pilot aileron speed control. |
| 32. Instrument spotlights. | 75. Manifold pressure gage. |
| 33. Electric panel lights. | 76. Eclipse engine synchronizer. |
| 34. Compass and gyro lights. | 77. Argonne light. |
| 35. Instrument light. | 78. Gyro pilot elevator speed control. |
| 36. Ignition switch. | 79. Rudder tab control. |
| 37. Beacon receiver tuning control. | 80. Selector valve for manifold pressure gages. |
| 38. Windshield crank. | 81. Propeller pitch latches. |
| 39. Clock. | 82. Kollsman sensitive barometric altimeter. |
| 40. Sperry gyro pilot rudder control knob. | 83. Fuel tank selector valve. |
| 41. Compass. | 84. Elevator tab indicator. |
| 42. Sperry bank and climb gyro. | 85. Carburetor heat controls. |
| 43. Spare light bulbs compartment. | 86. Free air temperature gage. |
| 44. Gyro pilot level flight knob. | 87. Auxiliary beacon volume control. |
| 45. Cambridge fuel analyzer. | 88. Local distance switch (auxiliary receiver). |
| 46. Window hand crank. | 89. Gyro pilot servo shut-off valve. |
| 47. Fuel pressure gages. | 90. Parking brakes. |
| 48. Clock. | 91. Beacon receiver volume control. |
| 49. Sperry directional gyro. | 92. Engine fuel selector valve. |
| 50. Cage knob for bank and climb gyro. | 93. Argonne light. |
| 51. Vacuum gage for Sperry gyro pilot. | 94. Nose vent control. |
| 52. Gyro pilot bank knob. | 95. Turn and bank vacuum selector valve. |
| 53. Gyro pilot climb knob. | 96. Gasoline gage selector switch. |
| 54. Vertical speed indicator. | 97. Aileron tab control. |
| 55. Sperry gyro horizon. | 98. Vacuum pump selector valve. |
| 56. Oil pressure gage. | 99. Cylinder heads temperature gages. |
| 57. Oil and temperature gages. | 100. Stewardess light. |
| 58. Carburetor and temperature gages. | 101. Safety warning lights. |
| 59. Primer. | 102. Stewardess switch. |
| 60. Cambridge exhaust gas analyzer junction box. | 103. Fuel pump selector valve. |
| 61. Kollsman sensitive field pressure altimeter. | |
| 62. Turn and bank indicator. | |

front of the instrument case. On the other three corners are molded lugs fitted with threaded brass inserts for receiving the mounting screws which secure the instrument on the panel. The lug inserts are all provided with self-locking devices of one kind or another.

(2) Instruments which have a total weight of more than 5 pounds use metal cases made of aluminum. Lighting and mounting features are practically the same and are comparable with those made of the phenolic composition.

j. Sizes.—With the exception of the gyro instruments and the automatic pilot control units, the mechanisms of which are too large, the mounting and dial diameters of all aircraft instruments are of two standard sizes, 1 $\frac{7}{8}$ inches and 2 $\frac{3}{4}$ inches. Most pressure gages,

thermometers, and clocks are placed in the smaller cases while the remainder require the larger size.

k. Operation markings.—Due to the wide divergence in the operating temperatures, pressures, and speeds, it is necessary to paint operation markings of various colors on the cover glass of some of the instruments.

(1) Engine instruments installed in aircraft are marked to indicate the operating limits prescribed in the various operating instructions for airplanes and engines. Air speed indicators installed in aircraft are marked with a red line extending from the center of the dial and passing directly over the point corresponding to the maximum permissible indicated air speed. The maximum permissible indicated air speed for each type airplane is that specified in the latest Air Corps Technical Orders or Operation Instructions.

(2) Lines are painted on the cover glass as shown in figure 2. Before applying markings, care should be taken to insure that the cover glass is tight in its case. Short radial lines are used to indicate limits. Arcs of circles are used to indicate the range in which a condition governs. A short radial index line is placed on the glass and case at the bottom of the instrument to make apparent any movement of the glass. The use of finely pointed brushes for the enamel and drafting pens and compasses for the lacquer should facilitate the application of these markings. To prevent a slippage of the compass on the cover glasses, the use of masking tape at the center of arc is suggested.

(3) A certain amount of parallax error is unavoidable with this system of marking unless the instruments are viewed directly from the front. In some of the later models of instruments now in use in service activities, provisions are made for adjustable colored markers to indicate the operating limits. The cover glasses of these instruments are not to be painted, as movable sections are provided to indicate the operating limits as required.

AIRCRAFT INSTRUMENTS

TM 1-413

2

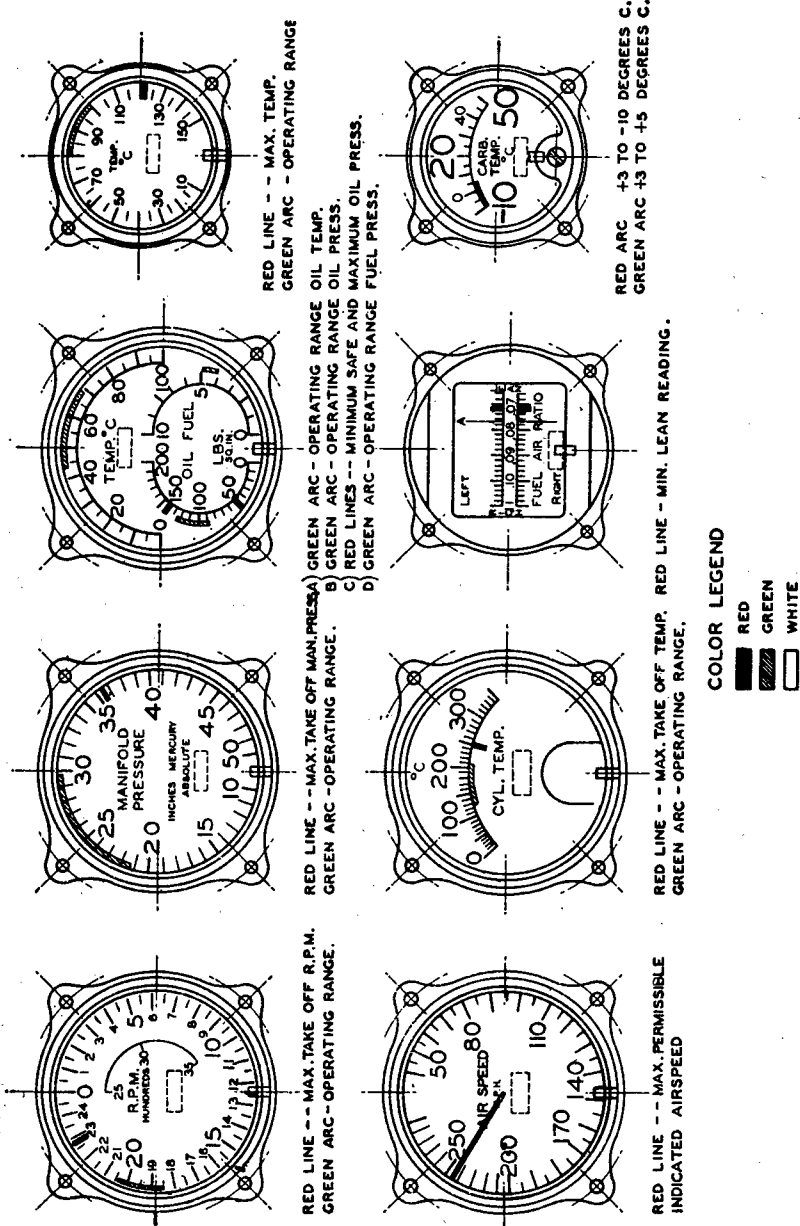

FIGURE 2.—Examples of operation markings on aircraft instruments.

SECTION II

MAINTENANCE, STORAGE, AND REPAIR

	Paragraph
Inspection.....	3
Removal and replacement.....	4
Common repairs.....	5
Packing, storage, and shipment.....	6
Reinspection and storage time limit.....	7

3. Inspection.—In order to maintain the highest possible standard of perfection in the accuracy and operation of aircraft instruments, certain checks and inspections are made at regular intervals. General instructions pertaining to these inspections and the accompanying maintenance and repairs are outlined in this section. Specific instructions for individual instruments are included with the detailed discussion of each instrument in succeeding sections.

a. Classification.—The repair, inspection, and maintenance of aircraft instruments may be classified as major repair, base repair, and line maintenance. The scope of the work performed in each of these classifications is definitely outlined in Air Corps Technical Orders and in general is based on the facilities which have been made available to the agencies doing the work. It is important therefore, that all maintenance personnel be informed as to the limits and restrictions placed on instrument repair.

(1) *Major repairs.*—This class of work is performed at depots only and consists of the application of luminous paint to dials and pointers, replacement of parts, adjustment of internal mechanisms, special lubrication, and all repair work that requires particular skill, special tools, jigs, and calibration equipment. When aircraft instruments are overhauled or repaired at depots they are insofar as practicable, equal to new instruments both as to accuracy and appearance. Depots prepare suitable log sheets for each instrument tested, identifying the instrument by serial number and showing the points, speeds, temperatures, etc., at which they were calibrated and, in addition, any variations between indicated and calibrated readings. These are retained by the instrument repair unit for possible future reference for a period of at least 2 years. Instruments of a particularly delicate nature are provided with stamped seals when they leave the factory or repair depot after a major overhaul, and service activities are not permitted to break this seal or open the case of these instruments.

(2) *Base repair.*—This work is performed at stations having base squadrons or detachments which function as the equivalent thereof. It consists of bench tests and related minor repair operations that are

beyond the scope of line maintenance and includes the reinspection of instruments carried in Air Corps stock at the various stations. The work is accomplished by specially trained personnel who are rated as instrument mechanics. They are familiar with the use and operation of shop and portable field test sets, and in some squadrons, their duties are extended to instrument trouble shooting on airplanes.

(3) *Line maintenance.*—This is the authorized instrument work performed by the crew chief and his assistants on the airplane. Normally it consists of the daily, preflight, 25-, 50-, and 100-hour inspections, such maintenance as may be required at these inspection intervals, and the removal and replacement of instruments.

b. Daily inspection.—This work is performed by the crew chief on the instruments each day and consists of checking—

(1) Pointers for excessive error at zero, except thermometers and absolute pressure-operated instruments, which should show indications consistent with surrounding temperature and pressure conditions.

(2) Instruments for loose or cracked cover glasses.

(3) Instrument lights for operation.

(4) Caging and setting knobs for freedom of movement and correct operation.

c. Preflight inspection.—This work is performed by the crew chief prior to the first flight of the day after the engines are started and consists of checking—

(1) Instruments pointers for excessive oscillation.

(2) Readings for consistency with engine requirements and speeds.

d. Fifty-hour inspection.—This work is performed by the crew chief, in some cases with the assistance of an instrument mechanic, and consists of checking—

(1) Instruments and dependent units for security of mounting.

(2) Lines and connections for leaks.

(3) Dial markings and pointers for dull and discolored luminous paint.

(4) Operation markings for correctness and discernibility.

(5) Electrical and bonding connections for good contacts and security of attachment.

(6) Vibration absorbers for security of attachment and proper tension.

e. Other inspections.—Other inspections, including 25- and 100-hour inspections, are applicable only to specific items on individual instruments and are discussed where necessary in succeeding sections.

f. Engine change inspection.—Normally this work requires the use of special portable and bench testing equipment and is accomplished by the instrument mechanic with the assistance of the crew chief.

4. Removal and replacement.—*a.* Instruments are removed and replaced for any of the following reasons:

- (1) Failure to indicate.
- (2) Inaccurate indication.
- (3) Leak in case.
- (4) Loose pointer.
- (5) Loose or cracked cover glass.
- (6) Defective lamp receptacle.
- (7) Broken or cracked mounting lug.
- (8) Defective setting or caging mechanism.
- (9) Defective binding posts or connecting nipples.
- (10) Dull or discolored luminous markings.
- (11) Any known or suspected defects in internal mechanisms.

b. The removal and replacement of instruments in airplanes require special care and attention. Some of the particular considerations necessary are as follows:

(1) Since these instruments are easily damaged, they should be handled carefully at all times and treated with the same care given an expensive watch.

(2) Unless specifically authorized to the contrary, instruments are always replaced with those of like kind and type.

(3) The location of an instrument or any of its dependent units is not to be changed without proper authority.

(4) When checking or testing an instrument, care is taken not to subject it to undue or abnormal pressures.

(5) If too much force is applied when inserting the mounting screws into the self-locking lug inserts, there is danger of pushing the inserts from the case.

(6) When making connections to the instruments, small tools are to be used and care taken not to twist or put excessive strain on the fittings.

(7) Instrument thread compound is used on all threaded connections.

5. Common repairs.—*a. General.*—(1) Common instrument repairs consist of—

(*a.*) Removal and replacement of cover glass.

(*b.*) Removal, balancing, and replacement of pointers (except on electrical instruments).

(2) Repairs of this nature are normally accomplished in the base instrument unit by specially trained personnel.

b. Removal of cover glass.—The cover glass is attached to the case of an instrument by means of a snap ring or cover glass hold-down ring. To remove the glass proceed as follows:

(1) When removing a snap ring, care should be exercised to see that the proper type tool is used to prevent scratching the glass or chipping the instrument case. After the snap ring has been removed, the sealing compound should be scraped away with a pointed orange-wood stick. A suction cup may then be used to remove the cover glass.

(2) To remove the cover glass from an instrument which employs a cover glass hold-down ring, it is first necessary to remove the ring screws. Inasmuch as the screws are made of brass and are easily damaged, it is essential that the proper size screw driver is used. If the screw slot has been enlarged to such an extent that a screw driver will not effect removal, it will be necessary to drill the screw and remove it with a screw extracting tool. The seal and seal screw must be removed before any attempt is made to lift the ring from the case. After removal of the ring and gaskets, the cover glass may be removed. Penetrating oil may be used to facilitate removal of corroded screws.

c. Replacement of cover glass.—When replacing a cover glass, the following procedure is used:

(1) The dial of the instrument is dusted with a camel's-hair or soft bristle dial brush.

(2) The pointer is inspected for proper attachment and correct zero setting.

(3) The cover glass is inspected for correct thickness and cleanliness.

(4) With a snap ring installation, after gaskets (if used) are properly installed, the cover glass is replaced, suitable sealing compound applied, and the snap ring inserted. With a hold-down ring installation, the gaskets and lighting ring are properly placed in their respective positions. The cover glass is then replaced in the case, the ring set in position, and the screws securely tightened. The seal screw should be resealed.

d. Removal of pointers.—An instrument pointer is lifted from the pointer staff by use of a small tool known as a pointer remover. Lifting of the pointer is accomplished by the tool "feet" which are applied to the under side of the pointer at the place of attachment to the shaft. The pointer of a chronometric tachometer must not be lifted before the pointer screw is removed. Scratching or marring

of the instrument dial may be avoided by using heavy paper at those points where the pointer remover touches the dial.

e. Balancing of pointer.—(1) It is essential that the pointer on the modern sensitive aircraft instrument is properly balanced. The check for static balance is accomplished by mounting the pointer on a balancing tool and testing for balance with pointer in various positions. The balancing tool consists of a pin vise and mandrel. The mandrel is inserted into the pointer bushing to support the pointer. The vise is held in a horizontal position, subjected to vibration, and the moving pointer permitted to come to rest. The pointer may be considered balanced if it comes to rest at random positions, whereas an unbalanced condition is indicated when either end consistently assumes a lower position.

(2) After it has been determined which half of the pointer is out of balance, a small amount of solder may be added to or removed from (depending upon condition indicated) the pointer balancing rivet. When adding solder, care should be exercised to protect the luminous paint on the pointer by wrapping a piece of moist cloth around the luminous portion. Minute out-of-balance conditions may be corrected by adding paint (dull flat black lacquer) to the balancing rivet or elsewhere along the back of the pointer, as determined by the balancing test. The paint on the pointer should be thoroughly dry before performing the balance check.

f. Replacement of pointer.—In some instances the bushing of a friction fit pointer may be found to be oversize. In such case the pointer should be replaced with a new pointer. If it is not possible to obtain a new pointer, and an emergency exists, the bushing of the old pointer is tinned and, if necessary, broached to fit the pointer staff. After the pointer has been replaced the instrument is held in several positions and lightly tapped to insure that the pointer has correct zero setting. The instrument should be operated to cause the pointer to deflect (in the positive direction); after the pointer returns to rest, the instrument is vibrated to note if the pointer returns to zero setting. After the setting is satisfactorily accomplished, a touch of paint (dull flat black lacquer) may be applied, if necessary, at the bushing portion of the pointer. The cover glass is replaced as heretofore outlined.

6. Packing, storage, and shipment.—*a.* Instruments are stored as received in the individual boxes from the manufacturer or instrument repair activities. Unserviceable instruments are likewise packed in individual boxes prior to shipment to depots for repairs, etc. Tissue paper, strips of corrugated paper, and packing felt are used to pack the instruments snugly and prevent their movement

within the boxes. Excelsior should never be used for this purpose. Each individual box is securely sealed with gummed paper strips and marked with the inspector's acceptance stamp, imprinted partly on the sealing strips and partly on the box, thus forming a visual means of preventing the removal of the sealing strips without detection. This does not apply to bulky, fragile, or extremely sensitive instruments that require special containers or special shock-absorbing mountings therein such as sextants, octants, chronometers, sensitive gyroscopic instruments, aperiodic compasses, etc., which are stored and shipped in the containers furnished by the manufacturer. Venturi tubes are not packed in the individual boxes with instruments but are packed in a separate container.

b. After packing in individual boxes, a printed form is completely filled out and pasted on each box. The data on this form include the name of the station performing the testing and inspection, date of such testing and inspection, name and type of instrument, manufacturer's part number, the Air Corps drawing or specification number, name of the individual performing the inspection, and storage expiration date. This information identifies the contents without opening the box and gives the storage expiration date.

c. The regular air transport supply service is utilized for the shipment of all types of aeronautical instruments whenever feasible. However, the following items are extremely delicate and if air transportation is not available are always shipped by express:

- (1) Flight indicators.
- (2) Turn indicators.
- (3) Navigation watches.
- (4) Octants.
- (5) Automatic pilot gyro controls.
- (6) Precision (type D) altimeters.

7. Reinspection and storage time limit.—*a.* When in stock, flight indicators, turn indicators, and automatic pilot control units are reinspected at the expiration of each period of 8 months from the date of last inspection; liquid-filled compasses, self-synchronous instruments, and altimeters at the expiration of each period of 1 year; all other instruments are reinspected at the expiration of each 2-year period. If, however, any question of serviceability of instruments in storage exists, more frequent inspections are performed as required.

b. After reinspection, each instrument if serviceable is properly packed, container sealed, and the printed form filled out and attached. The instrument is then returned to stock for issue. However, if the instrument is found to be unserviceable and cannot be repaired

locally, it is forwarded to the nearest repair depot for reconditioning. The limitation of repair by base squadrons is outlined in paragraph 3a(2).

c. Each instrument in a packing box, the sealing strips of which have been broken, is reinspected for serviceability before being returned to stock or issued for service. Each instrument in supply stock is considered unserviceable when the storage limit date as shown on the form secured to the packing box has expired, and is then turned over to the base squadron instrument repair unit for reinspection. Where facilities are not available locally for the work, instruments are returned to the depot for reinspection.

SECTION III

INSTALLATION

General.....	Paragraph 8
Mounting panels and connections.....	9
Installation instructions.....	10

8. **General.**—Because of wide variation in construction, dependent units, and function of aircraft instruments, there are necessarily different methods and procedures for the installation of the various types. There are, however, some instructions common to all installations which are discussed in this section. The detailed installation instructions for each instrument are presented in succeeding sections with the general discussion of that particular instrument.

9. **Mounting panels and connections.**—a. Instrument panels are made of 0.125-inch sheet aluminum or aluminum alloy. On panels of excessive width or depth, it is necessary to add stiffeners to provide the required strength and rigidity. All surfaces of the panel and the faces of all instruments have a dull or black satin finish which causes the luminous markings on the dials and pointers to stand out more clearly. If crash pads are used to surround the instruments the same color of finish is used.

b. Dimensions of instrument panels vary with the different sizes of airplanes. Normally all of the frontal space available is required to mount the instruments. As the size of the airplane increases, the number of instruments also increases because of the additional number of engines used. On some of the smaller airplanes the width of the fuselage in the pilot's cockpit does not permit enough frontal space on the instrument panel and it is necessary to add auxiliary panels for switches, control handles, etc., at the sides of the fuselage. Height of panels may be two-, three-, or four-tier depending upon the

space available. As nearly as possible, flight instruments are located so they are at eye level with the pilot when he is sitting in a normal position in the cockpit. All other instruments are located around this group as conveniently as possible.

c. All instrument panels are shockproofed. The standard method is to mount the panel on rubber shock-absorbing mounts. These absorbers are used in pairs; one is attached to a bracket fastened to the panel and the other to a bracket attached to a solid member of the fuselage as shown in figure 3. The proper size and location of each absorbing unit are determined by the airplane manufacturer when installed at the factory. In the service, periodic inspections are required of each of the units to locate any defects or breaks in the rubber cups. If a replacement is necessary, care should be taken to replace the defective one with the proper size. The load rating of each absorber is stamped on the inner ring of the cup.

d. (1) The majority of all aircraft instruments are dependent upon proper connection either to the engine or some of its accessories or to some other independent operating unit. Since the instruments are mounted on shockproof panels, all connecting lines leading to or away from the instruments must be provided with a length of flexible line immediately back of the instrument. Where lines made of metal tubing are used, this is accomplished in either of two ways. In most cases, a standard flexible connection is used. This consists of a 10- to 14-inch length of pressure resistant synthetic rubber tubing with suitable fittings at each end. Where the standard flexible connection cannot be used, it is necessary to place a coil in the tubing close to the instrument to provide the required flexibility.

(2) Electrically operated instruments are connected by either the common eyelet type of terminal soldered to the lead and secured on a binding post with a nut, or by special multiple line plug connectors.

(3) All instruments requiring tubing connections are provided with union nipples. These nipples have a pipe thread on one end and a straight thread on the other. The pipe thread end must always be inserted into the instrument. This standard rule is applicable to all instruments which require tubing connections. Connection of the tubing to the other end of the nipple requires a silver-soldered cone and cone union nut. Variation from this standard practice where it is desirable to use either two- or three-piece solderless connections is possible by the use of special adapters.

10. Installation instructions.—*a.* Standard hardware is used in all instrument installations. The tubing diameter and wall thickness and the specific items of connection or fittings are specified for each

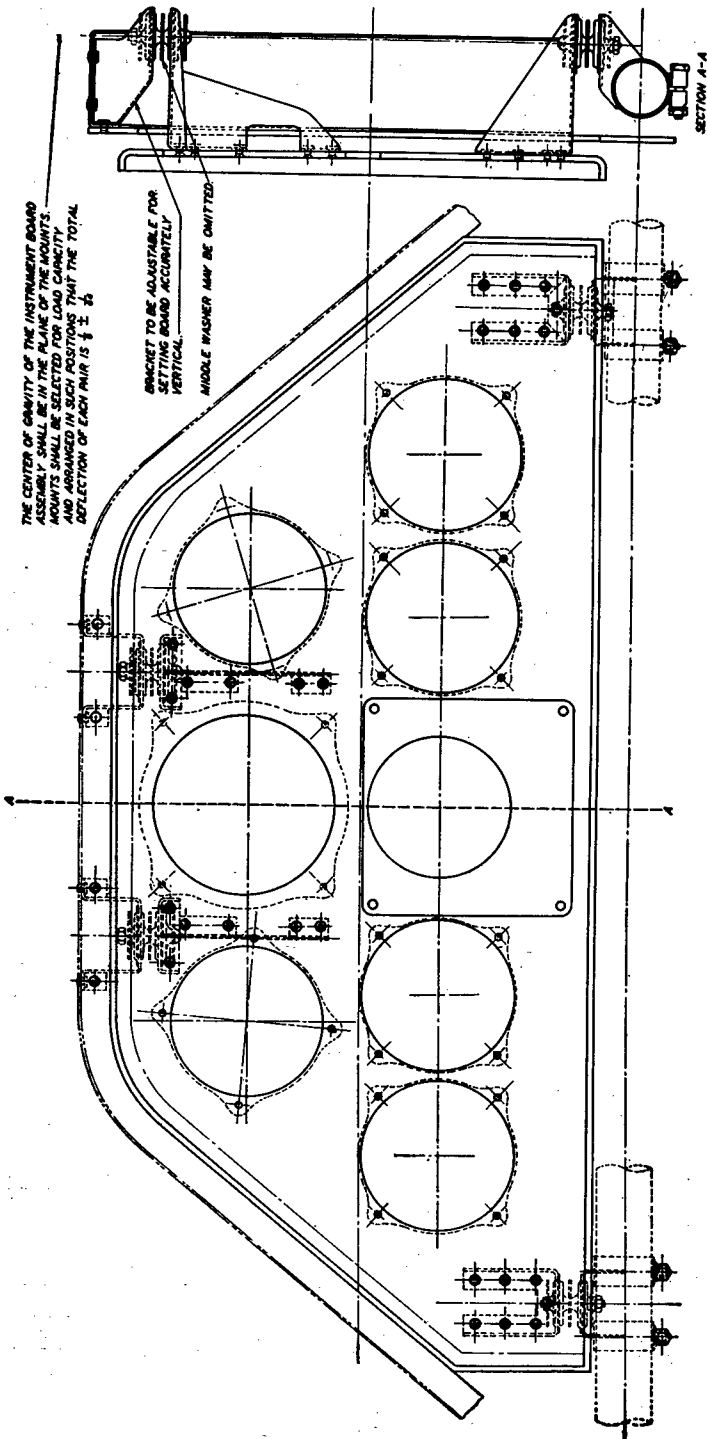

FIGURE 3.—Method of instrument panel shockproofing.

installation by Air Corps Technical Orders and installation drawings. All tubing should have a minimum number of bends. In vacuum lines particularly these bends should have radii as large as possible. Connections may be of the two-piece solderless, three-piece solderless, or silver-soldered cone types, care being taken, if the connections are threaded, that the correct thread is used in each case. Figure 4 shows a diagram of a typical instrument installation.

b. All connecting lines, tubes, leads, capillaries, etc., should be securely anchored at not less than 18-inch intervals and properly bonded. Unless otherwise directed, all replacements are duplicates of the original installation.

c. Care is taken that the connections of units sealed during manufacture such as thermometer capillaries, liquidometer capillaries, and other calibrating units are not broken, as this damages them beyond economical repair.

d. Standard aircraft power and lighting cable of either the shielded type or unshielded in aluminum conduit is used to connect all electrical instruments to their dependent units. The sizes, type of shielding, and terminals, etc., required for each installation are specified in Air Corps Technical Orders and installation drawings.

SECTION IV

FUEL PRESSURE GAGES

	Paragraph
Purpose and use.....	11
Description.....	12
Operation.....	13
Installation.....	14
Maintenance.....	15

11. Purpose and use.—The fuel pressure gage measures and indicates the difference between the air and fuel pressures at their respective inlets to the carburetor. The specific uses of this measurement are to—

a. Warn the pilot of impending engine failure due to failure of the fuel pump, a broken fuel line, or any other cause which prevents the fuel from reaching the carburetors under sufficient pressure.

b. Indicate that fuel is being supplied to the carburetors steadily under the proper pressure before the take-off. This is a check on the functioning of the fuel pump, the relief valve, and to a certain extent the entire fuel system.

c. Indicate uninterrupted flow of fuel to the carburetors while switching from one fuel tank to another.

AIR CORPS

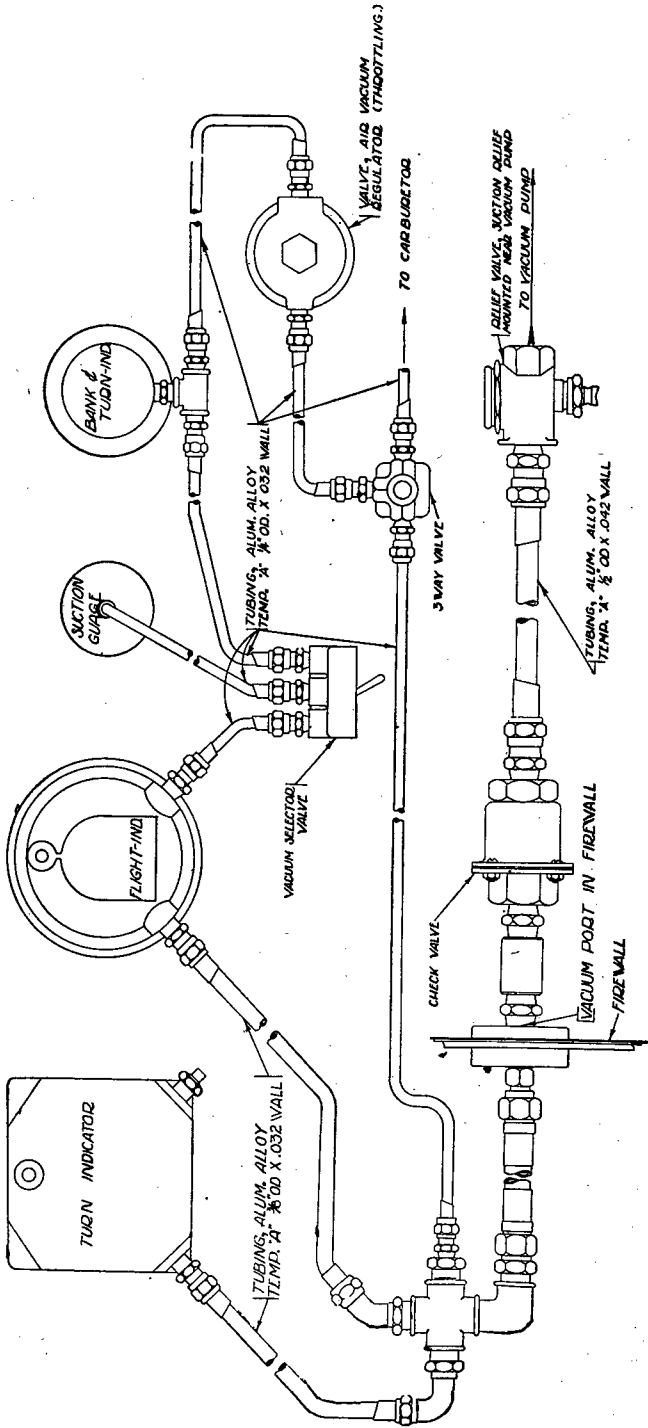

FIGURE 4.—Vacuum-operated instruments on an airplane installation.

d. Indicate proper fuel pressure relief valve adjustments for the various aircraft fuel systems.

12. Description.—*a.* The standard fuel pressure gage (fig. 5) is sealed airtight. It has a $1\frac{7}{8}$ -inch case and dial with a 3-volt built-in light. Two $1\frac{1}{4}$ -inch tube nipples are provided in the back of the case. These nipples, marked "Fuel" and "Air," serve to connect the instrument to the engine fuel system. On internally supercharged engines only the "Fuel" connection is made. The air vent remains open and therefore the air pressure in the instrument case will be atmospheric or cockpit pressure. On externally supercharged engines the air vent connects to the air pressure chamber of the supercharger. In either case, the instrument measures and indicates the difference in pressure of the fuel and air at their intakes into the carburetor.

b. The fuel pressure gages used with pressure discharge carburetors have ranges from 0 to 25 pounds per square inch, while the gages used with all other types of carburetors have ranges from 0 to 10 pounds per square inch. In both cases, the dials are graduated in increments of 1 pound per square inch. The numerals and pointer are painted with radioactive luminous material for visibility at night under normal night conditions.

c. Figure 6 shows a cross section of a pressure gage of the Bourdon tube construction. A tube is led from the point where pressure is to be measured to the connection *A* at the back of the gage case. The pressure is transmitted through the opening *X* to the inside of the Bourdon tube *T*. The Bourdon tube is made of spring-tempered brass or bronze tubing which has an elliptical cross section and is sealed at the outer end *M*. This end of the tube is free to move. The opposite end *N* is fastened rigidly to the instrument case and is stationary at all times.

13. Operation.—*a.* The Bourdon tube, due to its spring qualities, will straighten out when internal pressure is applied. This straightening movement is resisted by the air pressure on the outside surface of the tube. Thus the gage is a differential pressure measuring device and any indication it gives is due to an internal pressure in the tube greater than the pressure on the outside. The tube will always return to its normal position when the pressure is released. The movement of the tube, which is proportional to the amount of this difference in pressures, causes a movement of the links, levers, and pinions as shown in figure 6. This principle of operation applies to all Bourdon tube mechanisms, the chief difference being in the wall thickness and stiffness of the Bourdon tube. As the range of the instrument is increased, a heavier Bourdon tube is used.

b. On engines using pressure discharge carburetors, the normal pressure reading is 13 to 15 pounds per square inch. With all other types of carburetors, including fuel injection systems, the normal pressure will be 3 to 5 pounds per square inch. The instrument is sturdy and rugged enough for the purposes intended and will stand, without seriously disturbing the calibration, overpressure equivalent to one-half its calibrated range. However, if the hand pump is used too violently, there is a possibility that excess pressures beyond the

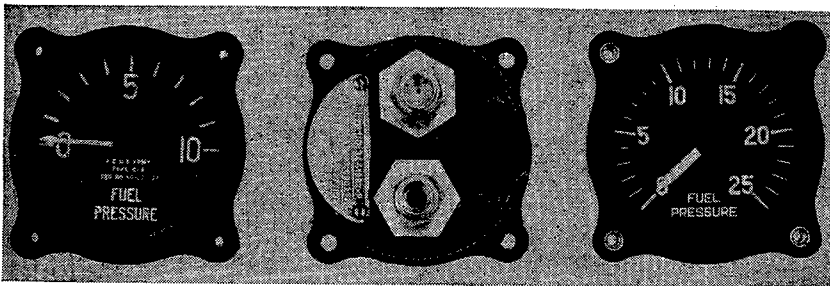

① A-0 to 10-pound gage. ② Rear view. ③ C-0 to 25-pound gage.

FIGURE 5.—Fuel pressure gage.

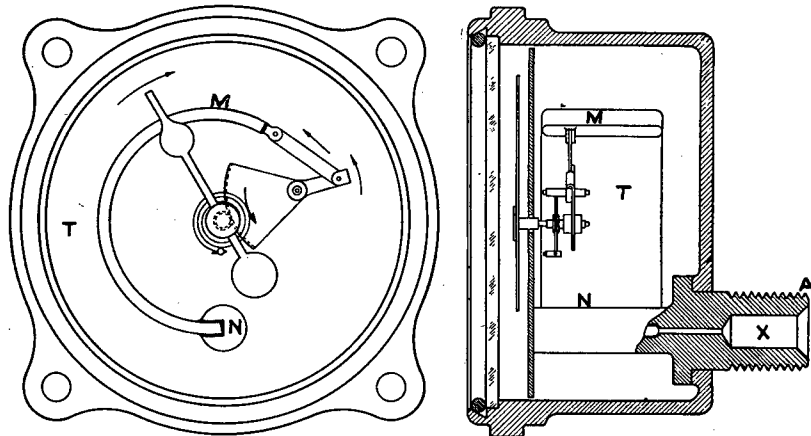

① Front view. ② Side view.

FIGURE 6.—Bourdon tube mechanism.

limits of the relief valve will be built up resulting in damage to the fuel pressure gage. It is therefore advisable when using the hand pump to watch the gage and keep the pressure within its range limits.

14. **Installation.**—See section III.

15. **Maintenance.**—See section II.

SECTION V
SUCTION GAGES

	Paragraph
Purpose and use.....	16
Description.....	17
Operation.....	18
Installation.....	19
Maintenance.....	20

16. Purpose and use.—*a.* The suction gages described herein are used on aircraft to indicate the amount of suction that actuates the air-driven gyroscopic instruments. In instrument flying it is particularly important that all flight instruments on the instrument panel function properly. Any reduction in the suction which actuates the gyroscopic flight instruments below that specified as normal will impair their functioning. Therefore a means must be provided continually to inform the pilot of the exact amount being provided.

b. The specific uses of suction gages are to—

(1) Indicate at all times the amount of suction in the vacuum systems of the aircraft.

(2) Give an indication of leaks that might develop in the vacuum system.

(3) Indicate the proper adjustment of the system relief valve.

17. Description.—The suction gage (figs. 7 and 8) consists of a case vented to the atmosphere, within which is a pressure sensitive capsule or diaphragm and a multiplying mechanism which amplifies the movement of the pressure sensitive element and transfers it to the pointer. The suction to be measured is admitted to the pressure sensitive element through a connection in the back of the case. The range of the gage is from 0 to 10 inches mercury (Hg.), the dial being graduated uniformly over the whole scale in increments of $\frac{1}{5}$ -inch Hg. Numerals are placed on the dial at 0, 2, 4, 6, 8, and 10 inches Hg. The scale utilizes 300° of the dial with the zero at the lower left side and the pointer moves clockwise with increasing suction. The hand, numerals, and "inch" graduations are painted with luminous material which under average conditions of night flying will give sufficient luminosity to be legible. All suction gages are provided with the standard 3-volt light. The light receptacle is built integral with the instrument case, which is of one-piece construction and has provision for holding the cover glass in position by use of a snap ring.

18. Operation.—*a.* The gage is connected directly into the vacuum system and indicates the amount of suction being provided to the gyroscopic instruments. The corrugated faces of the pressure capsule

are reacted upon by suction through the connection on rear of the case, and the magnitude of deflection of the capsule walls depends upon the amount of suction. This deflecting, when transferred from the diaphragm through the rocker shaft, sector, and pinion to the pointer, gives a continuous indication, and any variation in the normal output of the pump or venturi tube will be immediately apparent.

b. On all standard installations the suction gage is connected by means of $\frac{3}{16}$ -inch tubing into the flight indicator because the air consumption of this instrument is greater than that of any of the other gyro instruments. With the suction relief valve adjusted so that the required amount of suction is available in this instrument, a reading on the gage indicates that there is suction in all of the gyro instruments. Variation in the amount of suction to these instruments is obtained by the use of restrictions placed in the line leading to them. The normal suction gage reading is 3.75 to 4.25 inches Hg.

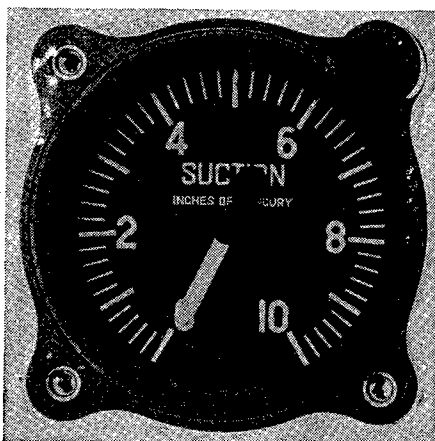

FIGURE 7.—Suction gage.

19. Installation.—*a.* The instrument is attached to the instrument panel in such a position that the pointer is horizontal when registering 2 inches Hg. When making the connection to the instrument, the threads on the nipple should be cleaned and a drop of oil added, care being taken to remove any deposits of solder from the union seat. The connecting nut is tightened until the nipple seals properly, producing a tight joint without excessive strain on the instrument. When the suction gage is mounted on a vibrationproof instrument panel and also connected to another instrument on the panel, no flexible connection is required; but if the connecting tubing is attached to a rigid portion of the airplane a suitable flexible connection must be used.

b. Suction gages equipped with built-in lighting are installed as above, except that they are mounted with three screws instead of four. The upper right-hand screw hole is notched out to accommodate the instrument lighting lug. Wiring is accomplished in accordance with the specific airplane installation drawing in which the equipment is installed.

20. **Maintenance.**—The general maintenance procedure outlined in section II is sufficient for this instrument.

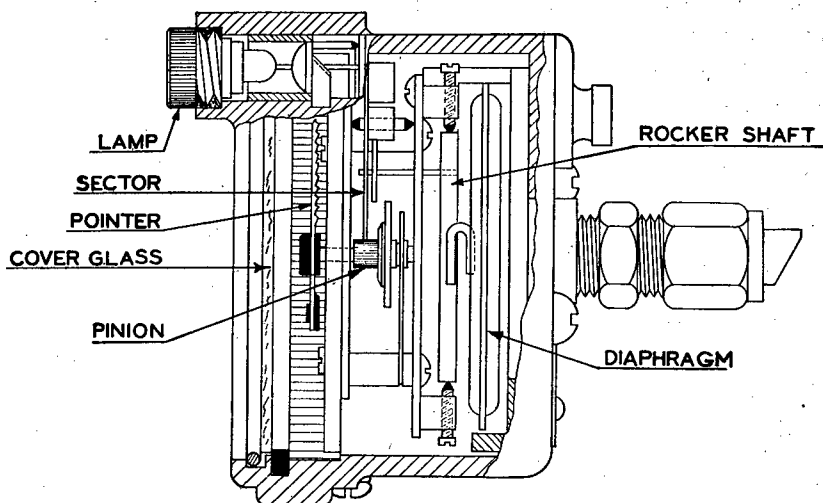

FIGURE 8.—Schematic cross section of a suction gage mechanism.

SECTION VI

MANIFOLD PRESSURE GAGES

	Paragraph
Purpose and use.....	21
Description.....	22
Operation.....	23
Installation.....	24
Maintenance.....	25

21. **Purpose and use.**—*a.* The purpose of this gage is to show manifold pressures under various engine operating conditions when the engine is equipped with a supercharger.

b. Specific uses of the manifold gage are to—

- (1) Prevent oversupercharging when operating engines at low altitudes.
- (2) Indicate loss of engine power when flying at high altitudes.
- (3) Indicate safe power output of engines.

(4) Serve as a guide when adjusting automatic controls for external type superchargers.

(5) Eliminate use of throttle stops.

22. Description.—*a.* The manifold pressure gage (fig. 9) consists of an airtight bakelite case containing an evacuated pressure sensitive capsule or aneroid, and a multiplying mechanism for amplifying the movement of the pressure sensitive element and transferring it to the pointer. The manifold pressure to be measured is admitted to the case through a connection in the back of the case. The corrugated faces of the pressure capsule are therefore acted upon by two pressures; one of very low value which is constant acting on the inside of the capsule, and the other a variable pressure acting on the outside of the capsule. The deflection of the capsule walls is therefore proportional to the difference in the two pressures and the instrument is thus completely self-compensated for changes in altitude or barometric pressure. The pressure inlet is fitted with a restrictor which effectively excludes foreign matter and also serves to dampen out rapid fluctuations of pressure.

b. There are two types of manifold pressure gages in service. One indicates absolute pressures within the range of 10 to 50 inches Hg. The range of the other is from 25 to 65 inches Hg. The dials of both are graduated in increments of 1 inch Hg. and numerals are placed at each 5-inch interval on the scale. The pointer, numerals, and main graduations are painted with a luminous material and under average conditions of night flying will give sufficient luminosity to be legible. The gages are provided with the standard 3-volt light with the receptacle molded integral with the instrument case or with reflected fluorescent light.

23. Operation.—*a.* The manifold pressure gage is designed to measure absolute pressure and its operation is continuous. When the engine is inoperative the gage reading will depend upon the local barometric pressure, and under these conditions functions the same as an ordinary barometer.

b. Figure 10 is an inside view in simple form of the manifold pressure gage. When the pressure transmitted through the tube connection on the rear of the case is raised or lowered, the aneroid, which is evacuated, contracts or expands. This movement is transmitted to the pointer *H* through the link *L*, rocking shaft *R*, sector *S*, pinion *P*, and staff *G*. The force of the hairspring *C*, which is supported on disk *D*, serves to keep all parts tight against one another.

c. Manifold pressure gage indications are governed by engine speeds and the type of supercharger employed. One type of supercharger, the internal or geared type, is located in the induction sys-

tem between the carburetor and the cylinder intake ports, and the manifold pressure gage indicates the pressure in the manifold between the supercharger outlet and the cylinder intake ports. When the external or exhaust driven type is used, the carburetor is located between the supercharger and the cylinder intake ports, and the manifold pressure gage indicates the pressure in the manifold between the supercharger and the carburetor. In engines equipped with fuel injectors, the manifold pressure gage indicates the manifold pressure immediately before the cylinder intake ports.

d. Although the manifold pressure gage is very sensitive, it is ruggedly built and will withstand the vibrations to which it is normally subjected under service conditions. However, it should not be submitted to rough handling.

e. When operating any of the modern aircraft engines, it is necessary to make a careful study of the handbooks and operations instructions for each engine to determine the maximum and desired manifold pressure readings for take-off, climb, dive, and cruising.

24. Installation.—*a.* The instrument is attached to the instrument panel in the space provided as shown on instrument panel drawing in such a position that the pointer is vertical when registering 30 inches Hg. When making the connection to the instrument, the threads on the nipple are cleaned and a drop of oil added, care being taken to remove any solder deposits on the union seat. The connecting union is tightened until it seals properly to give a tight joint without subjecting the instrument to excessive stress.

b. Whenever the instrument is installed on a vibrationproof instrument board, a length of flexible metal tubing approximately 10 inches long is connected between the instrument and the copper tubing extending to the engine manifold point of connection. A drain cock is located in the line, as close to the instrument connection as possible, for clean-out purposes. The control handle for opening and closing this valve is located so that it can be operated conveniently from the pilot's seat.

c. In addition to the above, the general installation instructions given in section III should be consulted.

25. Maintenance.—*a.* When the engine is inoperative, the manifold pressure gage reading should correspond to the local barometric pressure. Since the airplane altimeter is a very accurate barometric pressure measuring instrument and its accuracy is very dependable, it may be used as a standard of comparison for checking the manifold pressure gage.

b. A manifold pressure gage may be checked with the airplane altimeter by first setting the pointers or hands of the altimeter to

zero and then applying vibration by tapping the panel lightly four or five times to remove any friction effects that may exist in the mechanism of either instrument. With the pointers of the altimeter set in this manner, the barometric scale on the altimeter will show the local pressure in inches of mercury. The reading of the manifold pressure gage should agree with this pressure within 0.4 inch Hg.

c. After the engine is started, the drain cock in the manifold pressure gage line should be opened for about 30 seconds while the engine is idling. This will clear the line and gage of any condensate that may have collected there. When the drain cock is closed and the engine is idling, the pointer should move to the left since the absolute pressure in the manifold will be low, that is, 10 to 15 inches Hg. As the throttle is advanced and the engine rpm increases, the pointer on the gage should move to the right or in a clockwise direction.

d. The pointer should always have a rather slow and steady movement and be free of any rapid oscillations regardless of how quickly the engine speed is accelerated or decelerated. Any variation in operation other than this is an indication of either of two defects: leak in the line or case, or improper damping adjustment.

e. The instrument may be checked and tested for case leaks and proper setting of damping adjustment by first disconnecting the line to the gage at the engine end and then applying pressure until the gage indicates 50 inches Hg. If the line is then closed, a leak will be indicated by a return of the pointer to atmospheric pressure. The proper adjustment for the restrictor is checked by suddenly releasing the pressure when the gage indicates 50 inches Hg. The indicator should reach 32 inches Hg. in not less than 1 second or more than 2 seconds.

f. The general maintenance operations for this instrument are covered in instructions given in section II.

SECTION VII

DE-ICING PRESSURE GAGES

	Paragraph
Purpose and use	26
Description	27
Operation	28
Installation	29
Maintenance	30

26. Purpose and use.—*a.* The de-icing system pressure gage measures and indicates the differential air pressure in the airplane de-icing system when this system is in operation.

b. The specific uses are to—

- (1) Show if there is sufficient pressure to operate the rubber expansion cells on the wings and stabilizers of the airplane.
- (2) Provide a means of measurement when setting the relief valve and regulator in the de-icing pressure system.

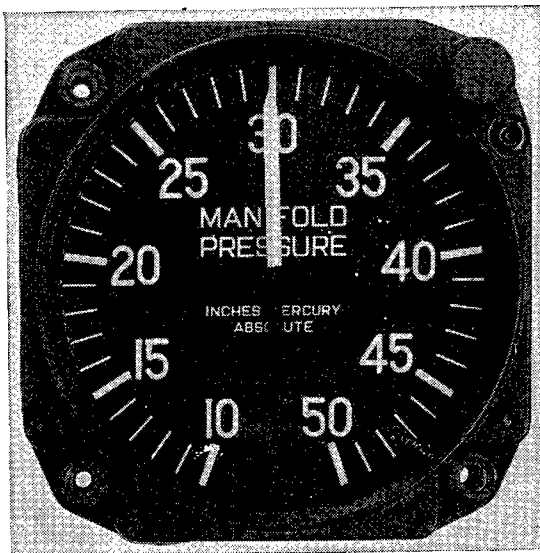

FIGURE 9.—Manifold pressure gage.

27. Description.—*a.* The de-icing system pressure gage (fig. 11) consists of a bakelite case containing a Bourdon tube and a sector gear with pinion for amplifying the motion of the tube and transferring it to the pointer. A vent at the bottom of the case keeps the inside at atmospheric pressure and also provides a drain for any accumulated moisture. The system pressure enters the Bourdon tube through a connection at the back of the case.

b. The range of the scale is from 0 to 20 pounds per square inch with graduations in increments of 2 pounds per square inch. The pointer, numerals, and main graduations are painted with luminous material. Individual lighting is provided by a small lamp inserted in the corner of the case.

28. Operation.—When installed on the airplane and connected into the de-icing pressure system, the gage reading will remain zero at all times except when the de-icing system is operating. Due to periodic inflation and deflation of the cells, the pointer of the gage will fluctuate from approximately 0 to 8 pounds per square inch. This is a normal fluctuation and should not be confused with pointer

TM 1-413
28-30

AIR CORPS

oscillation which is not a normal condition in any airplane gage and which, if present, must be corrected.

29. Installation.—See section III.

30. Maintenance.—See section II.

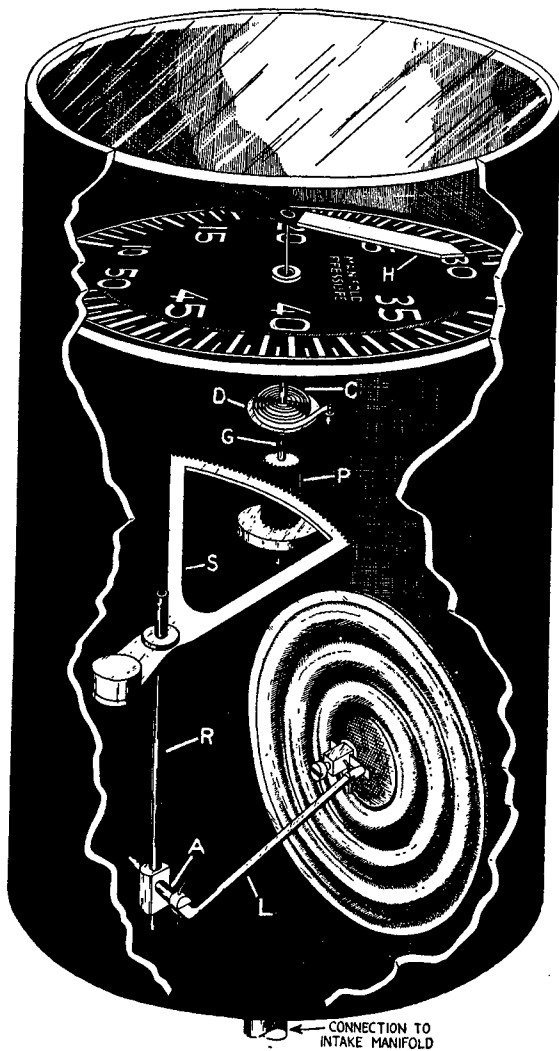

FIGURE 10.—Manifold pressure gage mechanism.

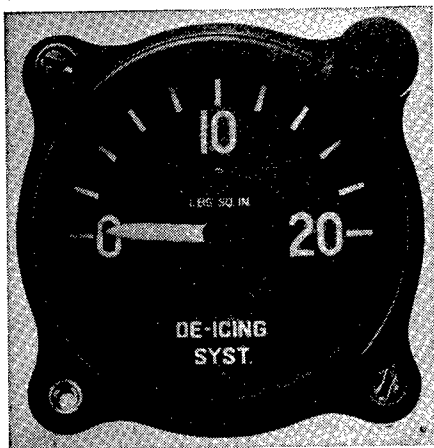

FIGURE 11.—De-icing pressure gage.

SECTION VIII

OIL PRESSURE GAGE

	Paragraph
Purpose and use.....	31
Description.....	32
Operation.....	33
Installation.....	34
Maintenance.....	35

31. Purpose and use.—*a.* Oil pressure gages are required on all types of aircraft engines to show the pressure at which the lubricant is being forced to the bearings and the various other points of the lubricating system.

b. Some of the specific uses of the oil pressure gage are to—

(1) Warn the pilot of impending engine failure due to exhausted oil supply, failure of the oil pump, burned-out bearings, broken oil leads, and other causes indicated by loss of pressure.

(2) Indicate to the pilot or mechanic that the oil is circulating under proper pressure before the take-off.

(3) Provide a means of measuring oil pressure during adjustment of the oil relief valve.

32. Description.—The standard type oil pressure gage (fig. 12) is a differential pressure measuring instrument having a Bourdon tube mechanism enclosed in a $1\frac{7}{8}$ -inch bakelite case. The range of this gage is from 0 to 200 pounds per square inch with the scale marked in 10-pound per square inch graduations. The gage is provided with a single connection on the back of the case which leads directly into the

Bourdon tube and has a 3-volt light, the light receptacle being molded integral with the instrument case.

33. Operation.—*a.* All aircraft engines are provided with engine-driven oil pumps so that whenever the engine is running, oil is forced through the engine under pressure. This pressure is controlled by a pressure relief valve which is adjustable and is set for the pressure recommended for the particular type of engine involved. The gage is connected into the system at a point between the relief valve and the engine.

b. Operation of the gage is the same as for any Bourdon tube instrument with one exception; the opening *X* into the Bourdon tube

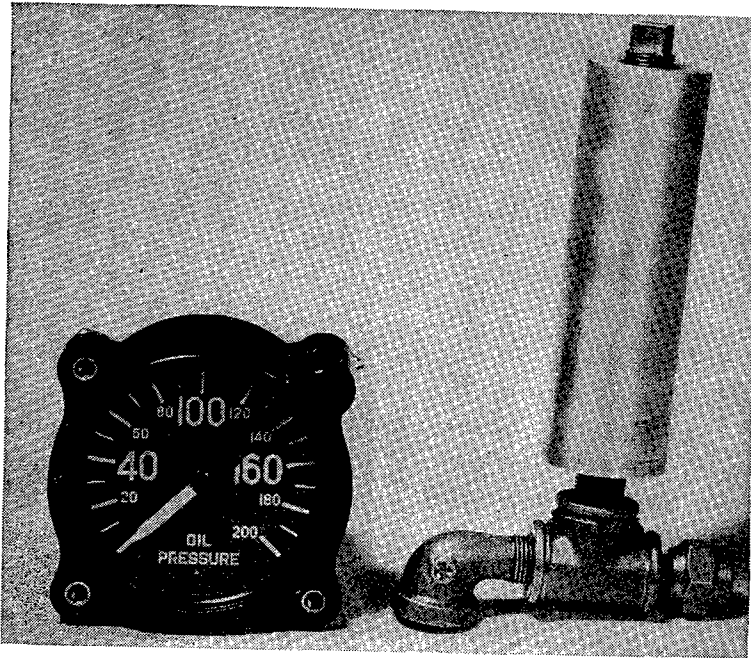

FIGURE 12.—Oil pressure gage and surge chamber.

(fig. 6) is very small compared with other pressure gages of this type. This restriction prevents the surging action of the pump from damaging the gage. Unless this provision is made, the pointer on the gage will oscillate violently through wide ranges so that it cannot be read accurately. Due to this restricted opening, under extremely cold-weather conditions and with the heavy oils that are used, the gage fails to indicate properly any pressure when the engine is first started. Under these conditions, the accuracy of the gage should not be doubted nor its operation questioned until the temperature of the oil reaches

the lowest point on the minimum marking of the oil thermometer which will occur after a few minutes running.

c. Engines which operate at pressures above 100 pounds per square inch must also have a surge chamber (fig. 12) connected into the line. The air that is trapped in the surge chamber when the line is connected to the instrument serves as a cushion for the pulsations in the oil pressure caused by the pump. This eliminates the hammer effect on the mechanism of the gage and prevents oscillation of the pointer.

34. Installation.—*a.* Surge chambers should be installed in the oil pressure gage line on all installations where specified.

b. The general instructions for installation of aircraft instruments given in section III apply to this gage.

35. Maintenance.—*a.* When sluggish operation of the oil pressure gage as evidenced by lag in indication is noticed during engine operation in cold weather, the line leading to the gage is disconnected, thoroughly drained, and refilled with aircraft instrument oil. This procedure is performed as often as necessary.

b. The general instructions on maintenance of airplane instruments given in section II apply to this gage.

SECTION IX

LANDING GEAR PRESSURE GAGE

	Paragraph
Purpose and use.....	36
Description.....	37
Operation.....	38
Installation.....	39
Maintenance.....	40

36. Purpose and use.—Landing gear pressure gages measure and indicate the differential pressure in the hydraulic system that is used to raise and lower the main wheels, tail wheels, flaps, and bomb doors and to operate the other hydraulic units. The hydraulic system of the automatic pilot, however, is provided with its own pressure gage.

37. Description.—*a.* The landing gear gage (fig. 13) consists of a bakelite case containing a Bourdon tube and a sector gear with pinion which amplifies the motion of the tube and transfers it to the pointer. A vent in the bottom of the case keeps the inside at atmospheric pressure and provides a drain for any accumulated moisture.

b. The scale of this gage ranges from 0 to 2,000 pounds per square inch and is graduated in increments of 200 pounds per square inch.

The pointer, numerals, and main graduations are painted with a luminous material and under average conditions of night flying will give sufficient luminosity to be legible. Each gage is provided with a 3-volt light, the light receptacle being molded integral with the instrument case. A $\frac{1}{4}$ -inch tube nipple is provided for connecting the gage into the hydraulic system.

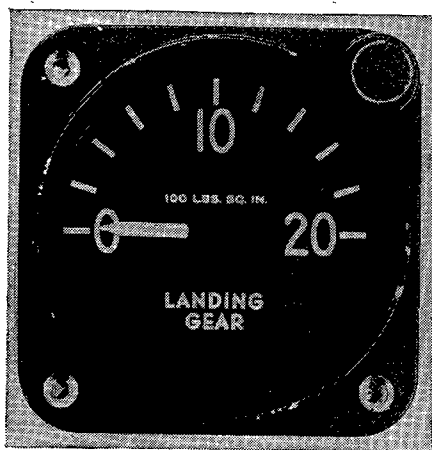

FIGURE 13.—Landing gear pressure gage.

38. Operation.—Pressure for the operation of the various hydraulic units on the airplane is obtained from hydraulic pumps. These are driven either by the airplane engine or by a separate electric motor. With the exception of the installations employing a pressure tank or “accumulator,” the operating pressure is built up only when needed; and since the landing gear gage is connected into some part of the main hydraulic system, the pressure will register on the gage only during these periods. When used in a hydraulic system employing a pressure tank, however, the gage will register continuously. While operating pressures of hydraulic systems vary for different airplanes, they generally fall in the range of 600 to 1,200 pounds per square inch.

39. Installation.—Due to the extremely high pressures employed in hydraulic systems, heavy walled tubing is used in the connecting lines. The general information on installation of aircraft instruments given in section III should be consulted for the installation of this gage.

40. Maintenance.—See section II.

SECTION X

ENGINE GAGE UNITS

	Paragraph
Purpose and use.....	41
Description.....	42
Operation.....	43
Installation.....	44
Maintenance.....	45

41. Purpose and use.—This instrument is a combination of a fuel gage, an oil pressure gage, and an oil thermometer in one standard $2\frac{3}{4}$ -inch instrument case under one cover glass. This consolidation reduces the amount of frontal space required for installation on the instrument panel and permits convenient association of these measurements which are so closely related. The specific uses of this instrument are the same as those given for individual instruments.

42. Description.—*a.* The engine gage unit (fig. 14) consists of three Bourdon tube mechanisms which measure fuel pressure from 0 to 10 pounds per square inch, oil pressures from 0 to 200 pounds per square inch, and oil temperatures from 0° to 100° C. Each of the three units is separate in its function and operation but all three are contained in a single three-piece case and all pointers and scales are placed on a standard instrument dial.

b. The thermometer unit is of the standard vapor pressure type using a progressively restrained Bourdon tube mechanism. It is made with various length capillary tubes ranging from 5 to 28 feet. The instrument case has a raintight seal only, so that atmospheric pressure is always present on the outside surfaces of the measuring elements. Tube nipples are located on the back of the instrument for line connections to the fuel and oil systems of the engine. The markings "Fuel" and "Oil" are molded in the case beside each nipple for identification when connections are made. The instrument is provided with an individual 3-volt light with the receptacle molded as an integral part of the instrument case.

43. Operation.—Operation of the units of this gage are the same as for the fuel and oil pressure gages and the oil thermometer.

44. Installation.—When connecting the units of this gage to the engine, be sure to attach the oil pressure line and the fuel line to their respective connections marked "Oil" and "Fuel" on the back of the instrument case, otherwise serious damage to the mechanisms will result when the engine is started. General information for the installation of this gage is given in section III.

45. **Maintenance.**—If any one of the three units of this gage becomes inoperative, it is necessary to remove and replace the entire assembly. Maintenance procedure for the units in this gage is the same as that described for individual gages.

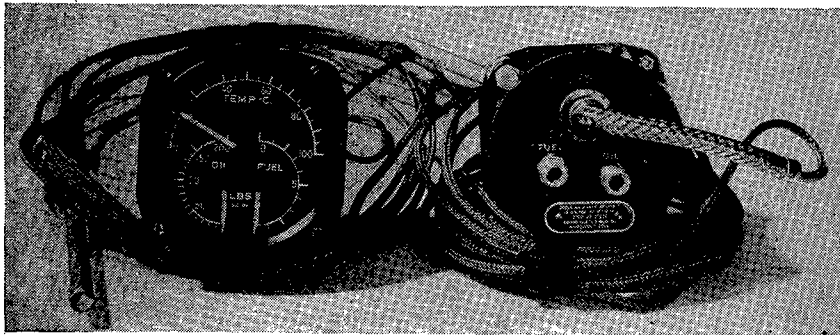

① Front view.

② Rear view.

FIGURE 14.—Engine gage unit.

SECTION XI

CHRONOMETRIC TACHOMETERS

	Paragraph
Purpose and use.....	46
Description.....	47
Operation.....	48
Installation.....	49
Maintenance.....	50

46. **Purpose and use.**—*a.* Chronometric tachometers are used on airplanes to measure the speed of the engine crankshaft. All standard types of this instrument are calibrated in revolutions per minute. The chronometric tachometer is very rugged, extremely accurate, and gives long periods of service with a minimum of maintenance and repair. However, its use is limited to single-engine airplanes because it is shaft-driven. Unsatisfactory operation results when the shaft length exceeds 20 feet or when the shaft must have an excessive amount and number of bends.

b. With the advent and use of adjustable pitch and constant speed propellers, actual uses of the tachometer are limited to the determination of the propeller speed. When using constant speed types of propellers, the instrument is used to check operation of propeller governors and controls during take-off and during variable altitude and density conditions. When using adjustable types of propellers,

the tachometer is used as a check when the propeller is changed from low to high pitch, or vice versa.

47. Description.—*a.* Standard types of chronometric tachometers (fig. 15) have a range of 0 to 3,500 rpm. All types are designed to be driven at one-half crankshaft speed, and are provided with a reversing mechanism to prevent damage due to engine kick-back. This mechanism also makes it possible for the drive unit to be driven either clockwise or counterclockwise. Since direction of rotation is optional, this feature need not be considered when connecting the instrument with the engine. The later types of chronometric tachometers are provided with two-piece cases, a 3-volt individual light, and a drive shaft "take-off" nipple which is located in the back of the case. The latter feature eliminates the necessity of having a 90° bend in the shaft.

1920 200

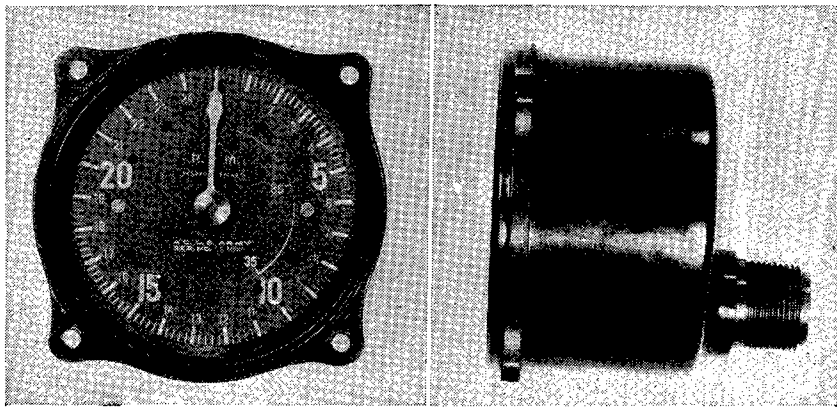

ⓐ Front view.

ⓑ Side view.

FIGURE 15.—Chronometric tachometer.

b. The mechanism of the chronometric tachometer (fig. 16) consists of the following four principal units:

(1) The driving mechanism *A* which takes the power from the flexible shaft and transmits it to the power plant.

(2) The power plant *B* which furnishes the power for driving the watch mechanism, counting mechanism, and synchronizing cams which time the action of the counting mechanism.

(3) The watch mechanism *C* which times the action of the synchronizing cams.

(4) The counting mechanism *D* which counts the revolutions transmitted to it during periods of 1 second each and indicates the results on the instrument dial.

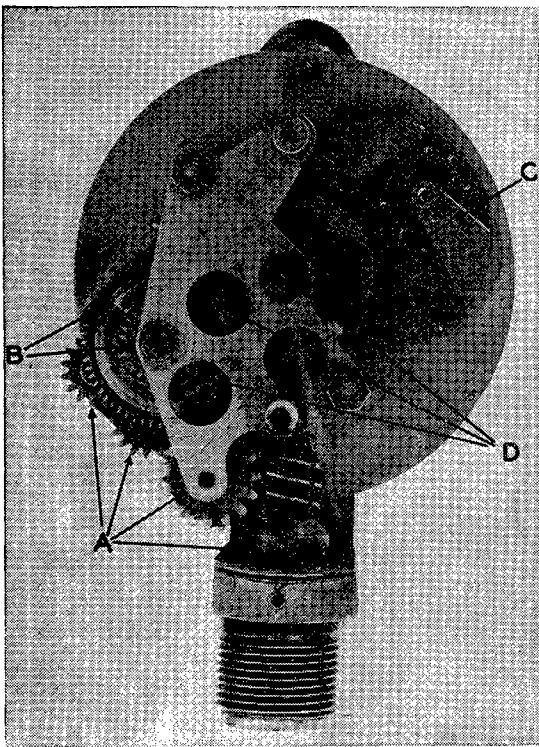
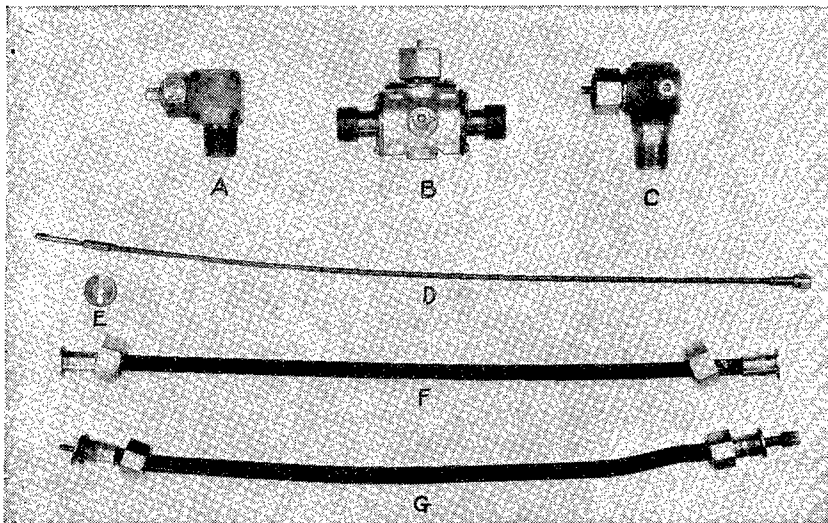

FIGURE 16.—Chronometric tachometer mechanism.

c. The drive shaft assembly (fig. 17) consists of the shaft proper which is made of hard drawn bronze wire, shaped in a coil form with suitable tangs soldered to each end for attachment with the engine and the instrument. The shaft in turn is placed in a braided copper-covered metal casing which serves as a bearing in which the shaft can rotate. All parts are nonmagnetic to eliminate interference with compasses and the covering on the casing serves as a shield to prevent interference with radio.

43. Operation.—This tachometer actually totals the revolutions (and fractions thereof) that occur during each alternate second. The seconds are automatically measured by a special watch escapement. The drive system, which consists of a chain of gears driven by the flexible drive shaft from the engine, operates the escapement cam and the counting system. The escapement cam being actuated by a friction drive causes a gear driven by the drive system to become meshed with the counting gear intermittently for 1-second intervals. During the 1-second intervals that these gears are in mesh, the large gear rotates a distance proportional to the speed of the



- | | |
|-------------------------------------|----------------------|
| A. Adapter 90° instrument end. | E. Retaining washer. |
| B. Adapter 180° two-way engine end. | F. Shaft casing. |
| C. Adapter 90° engine end. | G. Shaft assembly. |
| D. Shaft. | |

FIGURE 17.—Tachometer drive shaft and accessories.

drive system. A stud on the lower side of the counting gear pushing against a stud on a wheel directly below the pointer gear rotates the indicator hand through the same distance as the counting gear. At the end of the second the counting gear is disengaged and returned quickly to its starting position by a spring, but the indicator hand is held stationary during this time. During the next second, if the engine has run faster than during the previous second, the counter gear pushes the indicator farther around the dial. If the engine speed has been less, the indicator is released and a spring causes it to drop back to the position of the counter gear at the end of the 1-second counting period. This arrangement causes the indicator hand to move by jerks and the indicated reading at any instant is the rate of speed of the engine during the previous second. As long as the drive shaft continues to rotate this cycle of operation continues automatically. After rotation of the drive shaft ceases, there will usually be heard a rhythmic ticking which is normal and is caused by the escapement continuing to beat under the tension of the mainspring until the energy stored up in the latter is expended. Under normal conditions this may be as long as 30 seconds.

49. **Installation.**—*a.* The general points on installation of instruments as given in section III are applicable to this instrument.

b. The following specific points will be observed when installing chronometric tachometers:

(1) That the correct length drive shaft is used.

(2) The drive shaft has as few bends as possible. In no case is the radius of any bend to be less than 6 inches. When sharp bends at the engine or instrument end of the shaft cannot be avoided in any other way, the 90° adapters as shown in figure 17 will be used.

(3) The drive shaft retaining washer (fig. 17) is always placed on the engine end of the shaft before the coupling nut is attached to the drive on the engine.

(4) The tachometer is always placed on the instrument panel so that the drive shaft "take-off" is at the bottom.

50. Maintenance.—a. All general points on maintenance of instruments as given in section II are applicable to tachometers.

b. The following specific points of maintenance procedure are applicable to chronometric tachometers:

(1) If the pointer jumps or acts erratically, the fault will often be found in the flexible shaft connection or whipping of the cable in the casing due to a "tight" radius, a dry flexible shaft, or misfit or worn-out shaft connections.

(2) If the instrument fails to indicate, it may be due to a broken cable, faulty connections, or drive gear at the engine connection. Care must be exercised in connecting the flexible shaft, as any force used will result in "cocked" connections and the breaking of cables.

(3) In replacing broken cover glasses, care must be exercised to avoid particles of dust or glass entering the mechanism. If such exposure has been unavoidable, the instrument should be carefully examined and tested before sealing with a new glass.

(4) When the tachometer is at zero or normal rest, the hand should point vertically and centrally through the zero graduation mark.

(5) Under no circumstances are these instruments to be lubricated by service activities.

(6) It is possible to reset the pointer on zero by removing the pointer screw and pointer and then resetting it at the proper position. Care should be taken when doing this not to injure the surface of the dial.

(7) If the flexible drive shaft becomes defective, it is replaced with a new one rather than repaired or lengthened.

SECTION XII

GENERATOR VOLTMETER TACHOMETERS

	Paragraph
Purpose and use.....	51
Description.....	52
Operation.....	53
Installation.....	54
Maintenance.....	55

51. Purpose and use.—Generator voltmeter tachometers are designed to measure the speed of the engine crankshaft in revolutions per minute. Since the operation of this instrument is independent of the distance between the engine and the instrument panel, it is a desirable tachometer for use on multiple engine airplanes or on two-place airplanes where complete sets of engine instruments are installed in both cockpits. Attempts to use shaft-driven tachometers with a special two-way adapter on the latter type installations have not proved satisfactory because the abruptness of the bends in the shafts causes wear and friction resulting in a quick deterioration of the shaft. The generator voltmeter tachometer is used on any installation, single or multiple engine, where there may be interference of fuel tanks, ammunition boxes, etc.; the distance from the cockpit to the engine is excessive; or multiple sharp turns would be required in a flexible shaft drive. In most cases it is given preference over the chronometric type when installation difficulties of this kind are encountered.

52. Description.—*a.* The generator voltmeter tachometer (fig. 18) is an electrical instrument composed of three principal units; the indicator, which is mounted on the instrument panel; the generator, which is attached to the tachometer drive of the engine; and the connecting leads which are of insulated low-voltage cable.

b. The mechanism contained within the indicator is a permanent magnet moving coil voltmeter which is directly connected to the pointer. This type of mechanism permits only 270° rotation of the pointer, and since the desired scale range is 3,500 rpm, the smallest scale units are 100 rpm. The case is of bakelite and is provided with a shield to prevent interference with the operation of the magnetic compass and radio. As with all other types of airplane tachometers the indicator mechanism is adjusted for a crankshaft speed ratio of 2 : 1.

c. The magnetic generator is a small compact unit designed so that it may be attached easily to the tachometer drive on all engines. The armature shaft is mounted in ball bearings and provided with a tang

for insertion into the drive unit on the engine. The brush gear and commutator are of conventional type and construction and are provided with suitable terminals for connecting the generator electrically with the indicator. Direction of the rotation of the generator is optional and will be governed by the particular type of engine to which it is attached. Referring to figure 18, if the direction of rotation is clockwise, the right-hand terminal will be positive (+), and if the direction of rotation is counterclockwise, the left-hand terminal will be positive (+). The leads are made of standard No. 18 aircraft power and lighting cable. This cable is copper wire, tin-coated, and covered with varnished cambric insulation. Lengths will vary to suit the requirements of any particular installation.

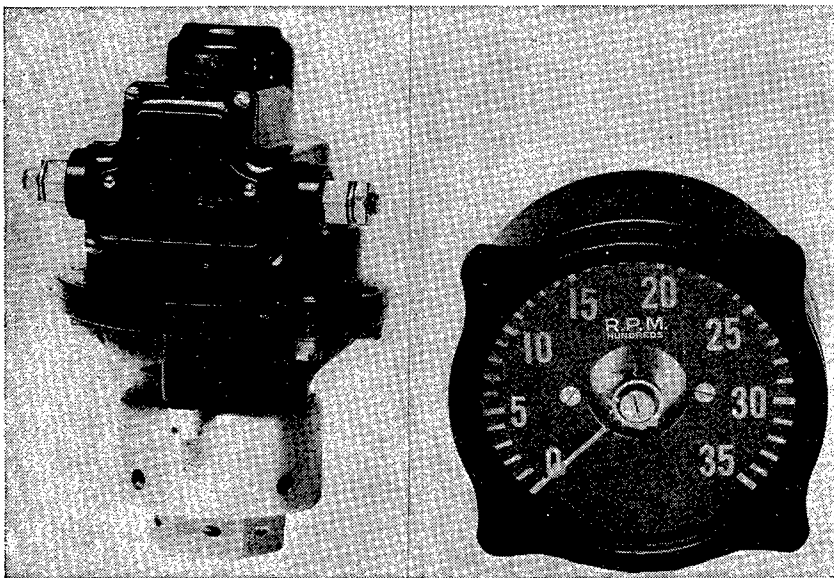

① Generator.

② Indicator.

FIGURE 18.—Generator voltmeter tachometer.

53. Operation.—The tachometer generator turns one-half crankshaft speed, and being connected electrically to the voltmeter indicator which is calibrated accordingly, an instantaneous reading on the indicator can be obtained. As the engine speed increases or decreases, the resulting reading on the indicator varies because the actual voltage output of the generator is directly proportional to the engine speed. Due to the perfect balancing of the coil and the fact that it rotates in jewel bearings, the pointer on the indicator does not oscil-

late to any great extent and a steady and accurate reading is possible at all times.

54. Installation.—*a.* The general points on installation of instruments as given in section III are applicable to this instrument.

b. The following specific points will be observed when installing generator voltmeter tachometers:

(1) When mounting the generator unit the threads on the tachometer drive outlet on the engine and the union coupling nut of the generator are cleaned and a drop of oil added. The generator is placed against the tachometer drive outlet on the engine and the union

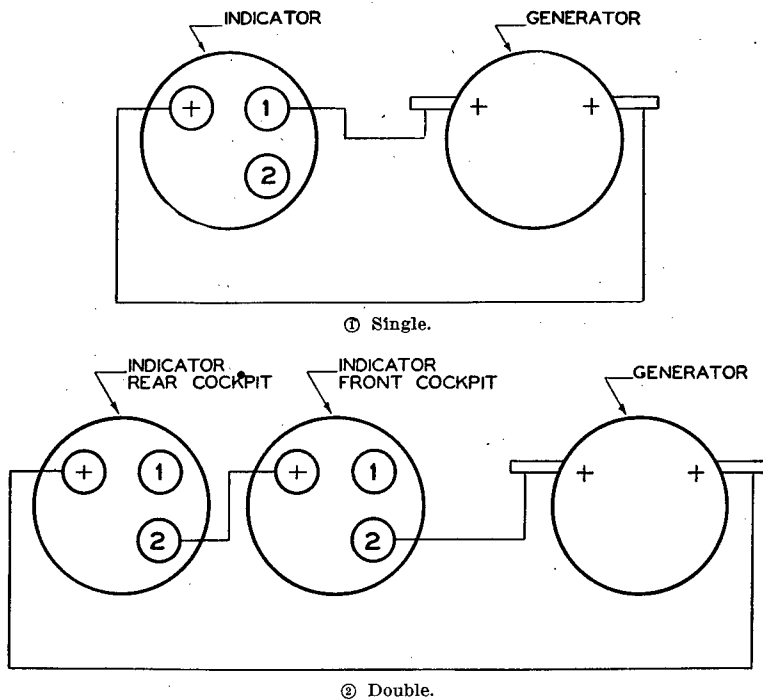

FIGURE 19.—Wiring diagram of generator voltmeter tachometer installation.

coupling nut tightened. It may be mounted with the terminal studs in any direction convenient for installation. The indicator is connected with the generator using suitable lengths of No. 18 cable, and no attempt should be made to substitute any other gage or kind of cable. If the indicator reads backward when the engine is started, reverse the connections of the generator. The direction of rotation of the generator armature is optional; however, if its rotation is reversed, its polarity is changed and the leads to the voltmeter indicator must be changed accordingly.

(2) This tachometer may be used with a single or double indicator installation for a single engine. In either case when making the connections with the indicator, locate the numbers and signs on the terminals and make the connections as shown in figure 19.

55. **Maintenance.**—*a.* The general points on maintenance of instruments given in section III are applicable to this instrument.

b. Several specific points of service maintenance and inspection of generator voltmeter tachometers must be considered. The generator and indicator units of this tachometer are sealed units and any repair or adjustments necessary to the internal mechanisms are major repairs. No lubrication on either unit is required in the field. Zero adjustment of the pointer on the indicator is provided by means of a small screw on the face of the indicator. This adjustment is permissible and may be accomplished when calibrating the indicator. Connection of the leads at all terminals must make clean contacts and should be safetied with lock washers to prevent looseness caused by engine vibration. The leads must be of the specified gage and long enough to prevent tautness at any point. Insulation of the leads must be unbroken at all points and the leads anchored to structural members of the airplane at proper intervals.

SECTION XIII

ENGINE SYNCHRONISM INDICATOR (WESTON)

	Paragraph
Purpose and use.....	56
Description.....	57
Operation.....	58
Installation.....	59
Maintenance.....	60

56. **Purpose and use.**—The synchronism indicator and the engine synchroscope (sec. XIV) are designed for use on multiple-engine airplanes for synchronism of two engines, eliminating the necessity of accomplishing this by sound or by readings on two tachometer indicators. The indication on these synchronizing instruments allows the pilot to adjust the throttles and mixture controls so that both engines and propellers are operating at the same speed. This minimizes the vibration and dissonant throbbing otherwise present.

57. **Description.**—*a.* The engine synchronism indicator (fig. 20) consists of a high resistance millivoltmeter which is adjusted to measure the unbalanced voltage generated by two tachometer generators running at slightly different speeds. The indicator scale has the zero mark in the center and a range in each direction of 50 rpm.

b. The voltmeter mechanism is placed in a 2¾-inch molded bakelite case. The instrument case is provided with a shield to reduce magnetic interference with compasses and radio equipment. Two conventional stud type binding posts protrude through the rear of the case for connection of the indicator to the tachometer circuits. These posts are marked + (positive) and - (negative). The instrument is provided with the standard 3-volt lamp, the receptacle being molded integral with the instrument case.

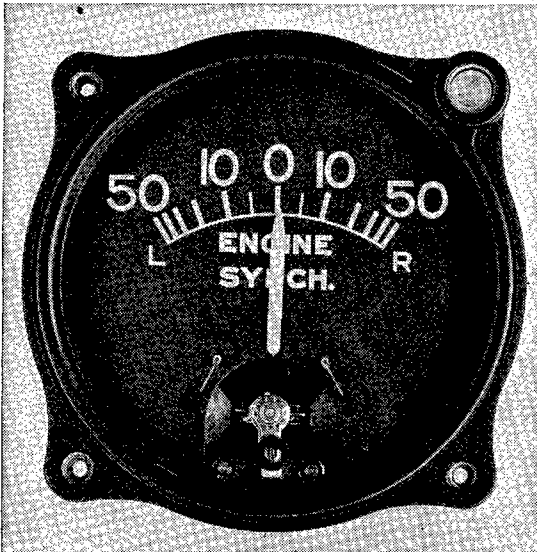

FIGURE 20.—Synchronism indicator.

58. Operation.—a. The synchronism indicator is connected into the circuit with the tachometer indicators and generators as shown in figure 21. Its indication and use are selective with that of tachometer indicators, the control gage switch having three positions, "off," "tachometers on," and "synchronizer on." For conventional operation the switch is set for the "tachometers on" position so that the engine speeds will show on each individual tachometer indicator. When the desired altitude has been attained and the airplane "trimmed," the switch is then set for the "synchronizer on" position.

b. Due to the difference in generated voltage of the two tachometer generators, the engine synchronism indicator shows the difference in speed of the two engines in revolutions per minute. A pointer movement in a clockwise direction indicates that the right engine is running at the greater speed and a counterclockwise rotation of the pointer indicates that the speed of the left engine is the greater. The throttles

are adjusted until both engines are running at the same speed and the pointer remains at zero. Accuracy is within 2 rpm. Due to the high torque imposed by the resistance, the sensitivity decreases rapidly at the outer end of the scale and the indicator will not be damaged by a tachometer generator speed difference up to 3,500 rpm.

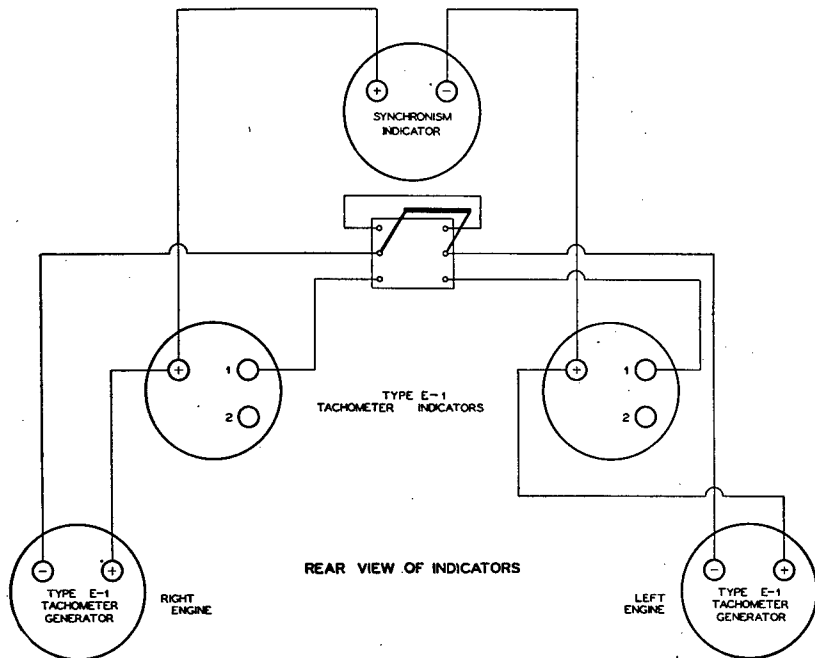

FIGURE 21.—Wiring diagram for installation of generator voltmeter tachometers and synchronism indicators.

c. After the synchronization procedure the switch position is optional. Simultaneous indication of the tachometers and indicators is not possible. It is necessary to select either one or the other and no damage will result by continuous or intermittent operation on either of the selective positions.

59. Installation.—a. The general points on installation of instruments given in section III are applicable to this instrument.

b. In addition to these, there are some specific points on installation which are applicable to this engine synchronism indicator.

(1) Before mounting the indicator, the two tachometer generators with which it is to be connected are adjusted to give identical output at the same rpm. The generators are attached to a tachometer test stand and wired to the synchronism indicator as shown in figure 22. The tachometer stand is run at approximately 1,800 rpm. and the reading of the synchronism indicator observed. If it is

off center, the adjusting screw cap is removed from one of the tachometer generators and the adjusting screw turned until the synchronism indicator reads zero. If the indicator is off center more than 10 rpm, half the adjustment is made on each generator. The adjusting screw caps are then replaced and safetied.

(2) If a tachometer stand is not available, the above check may be made on one of the engines of the airplane by connecting one of the tachometer generators to each of the tachometer outlets and running the engine at approximately 1,800 rpm. The error in the synchronism indicator at any other speed must be within 2 rpm.

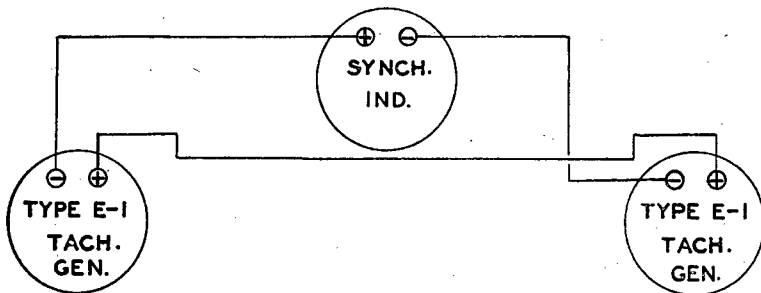

FIGURE 22.—Wiring diagram for connecting two tachometer generators with a synchronism indicator when making bench tests and shunt adjustments.

(3) By means of the zero corrector located at the bottom of the front cover glass, the pointer is set, using a small screw driver, to a point on the scale corresponding to the 0 reading. After this operation it will not be necessary to reset the pointer unless the zero corrector is moved accidentally. After the indicator is mounted on the instrument panel it is connected to the two tachometer circuits as shown in figure 21, using No. 18 gage shielded low voltage airplane power and lighting cable. These connections must be clean and tight, otherwise resistance will be introduced and the readings incorrect.

60. Maintenance.—The general points on maintenance of instruments given in section II are applicable to this instrument. When the generators and indicators are removed for periodic adjustment, the same procedure is used as that preceding the installation.

SECTION XIV

ENGINE SYNCHROSCOPE (ECLIPSE)

	Paragraph
Purpose and use.....	61
Description.....	62
Operation.....	63
Installation.....	64
Maintenance.....	65

61. Purpose and use.—The use of this instrument is the same as the engine synchronism indicator as given in paragraph 56.

62. Description.—*a.* The engine synchroscope consists of a sensitive voltmeter mechanism contained within a standard $1\frac{7}{8}$ -inch bakelite case as shown in figure 23. The case is provided with a two-piece aluminum shield to prevent static disturbance in radio and compass equipment in the airplane. The scale is an arc of approximately 180° without graduations of any kind. The pointer is covered with luminous material, provided with a zero adjuster, and mounted on a shaft which rides in jewel bearings, thereby reducing friction to a minimum and making it extremely sensitive.

b. A condenser unit built into a metal shield is provided to smooth out the pointer movement and prevent excessive oscillation due to

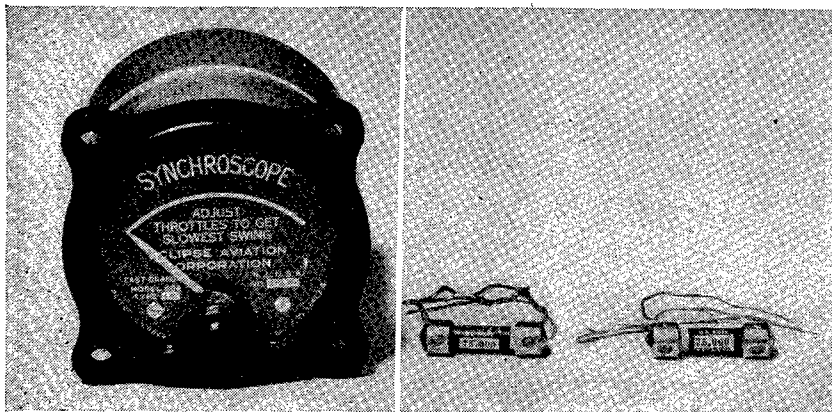

① Indicator.

② Resistors.

FIGURE 23.—Synchroscope.

slight variations in frequencies. It is attached to the rear section of the instrument case shield. Three pairs of resistors are provided with each instrument having resistance values of 35,000 ohms, 50,000 ohms, and 75,000 ohms. They are cartridge type and uniform in over-all dimensions. The three sizes are furnished to meet the variation in voltage of different types of engine magnetos. A No. 18 solid copper wire is silver-soldered into each end of the resistor for attachment into the magneto circuit.

c. Two single pole, single throw switches are used to turn the synchroscope off and on.

63. Operation.—The synchroscope and its resistors are connected between the primary circuits of two magnetos; that is, one magneto on each engine. Connections are made at the magneto switches as shown in figure 24. When connected to the two magneto switches,

two alternating voltages whose frequencies depend on the engine rpm are applied to the instrument. The sum of two alternating voltages of different frequencies produces "beats" or "nodes" in voltage which occur at regular intervals depending on the difference in rpm of the two engines. Each "beat" in frequency produces one complete swing of the synchroscope pointer. At exact synchronism the two voltages add to produce a steady alternating voltage of constant magnitude having no "beats." The pointer therefore stops at a steady indication. Due to variation in magneto construction the resistance necessary to produce the correct deflection will range from 70,000 to 150,000 ohms.

64. Installation.—*a.* The general points on installation of instruments given in section III are applicable to this instrument.

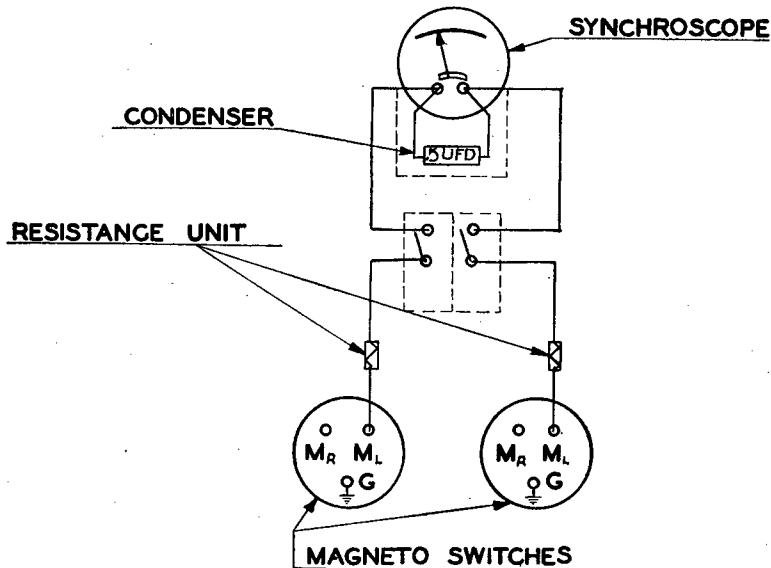

FIGURE 24.—Diagram of a two-engine synchroscope installation.

b. The instrument, resistors, and switches are connected as shown in figure 24, using not less than No. 16 gage cable, care being taken that the synchroscope is connected to only one magneto lead from each engine. The synchroscope control switches are located as close to the magneto switches as possible. The insulation of the leads between the switches and the instrument must not be broken at any point as a ground in any part of the synchroscope circuit will cause one or both magnetos to cut out.

c. In making an initial installation of the synchroscope, the two 50,000-ohm resistors are used first. One engine is operated at 1,200

rpm and the other at 1,500 rpm. Under these conditions the synchroscope needle should have a deflection of approximately one-half the scale. If the deflection is less than this, the two 35,000-ohm resistors are then used. If the pointer deflection is more than one-half full scale, the 75,000-ohm resistors are used. After the correct size of resistor has been determined on the initial trial, the same size is used for replacement unless otherwise directed. It is essential that each pair of resistors on any installation be of the same size.

65. Maintenance.—The general points on maintenance of instruments given in section II are applicable to this instrument. When the synchroscope is not in operation, the pointer should stand at the left end of the scale. A small screw is located at the bottom of the instrument in the cover glass for adjustment purposes when it becomes necessary.

SECTION XV

VAPOR PRESSURE THERMOMETERS

	Paragraph
Purpose and use.....	66
Description.....	67
Operation.....	68
Installation.....	69
Maintenance.....	70

66. Pressure and use.—*a.* Thermometers are used on the airplane to measure and indicate the temperature of—

(1) Cooling liquid in liquid-cooled engines. This measurement is made at some point in the cooling system between the engine outlet and radiator inlet.

(2) Engine lubricating oil. This measurement is made at the oil inlet to the engine.

(3) Carburetor mixture. This measurement is made in the carburetor throat.

(4) Air inside and outside of cockpits and cabins. These measurements are made in the cockpit or cabin and at some external point on the airplane surface.

b. Some of the uses of the aircraft cooling liquid thermometer are to—

(1) Enable the pilot to operate the engine within the temperature range at which best efficiency is obtained. Most liquid-cooled engines should be operated at a temperature of 70° to 160° C. To prevent rapid loss of liquid the temperature should always be held below the boiling point. While the boiling point of ethylene-glycol is 192° C. at

sea level, it is only 175° C. at 20,000 feet altitude; consequently, at that altitude the engine must be operated at a correspondingly lower temperature. Shutters on the radiator enable the pilot to control the temperature in normal operation.

(2) Warn the pilot of engine overheating. Certain engine troubles are first indicated by overheating and if noticed in time by the pilot, the airplane may be landed with power before complete engine failure occurs.

(3) Indicate to the pilot or mechanic while warming up the engine on the ground when the engine has warmed up sufficiently for the take-off and flight. In general, the cooling liquid temperature should reach at least 70° C. before the take-off is attempted.

(4) Warn the pilot of the engine cooling too much during long glides. If the engine becomes too cool, it may backfire or stop when the throttle is opened suddenly.

c. Some of the uses of the aircraft oil thermometer are to—

(1) Indicate in warming up the engine on the ground whether the oil has reached a temperature sufficient for the take-off. In general, the oil temperature should reach 30° C. before the take-off is permitted.

(2) Enable the pilot to adjust the oil coolant radiator control or check its operation when automatic control devices are employed.

d. Some of the uses of carburetor mixture thermometers are to—

(1) Indicate low temperatures in the carburetor throat which under certain humidity conditions would result in the formation of ice within the carburetor.

(2) Indicate high temperature in the carburetor when the heater is being used, which would cause detonation and loss of power.

e. Free air thermometers are used to indicate temperatures inside and outside the cabin and cockpits. Inside temperatures are necessary to provide comfort for the passengers. Outside temperatures are important in the general operation of the aircraft, especially when the moisture content of the air is such that there is danger of ice formations on the lifting surfaces of the airplane. Thermometers of this type are generally called ice-warning indicators. In construction and appearance they are the same as the distant reading types of engine thermometers, the exceptions being that they have a shorter range and the scales have characteristic markings at the critical range where ice formations occur, that is, at 0° C. or +32° F. Due to the dependence which is placed on free air thermometers in flight, they are built and calibrated very accurately and can be used at any time as a master to check other thermometers on the airplane, provided that at the time of comparison the bulbs of both thermometers are

exposed to the same medium. These thermometers are also used when it is necessary to take the temperature of the free air surrounding the aircraft at various altitudes. With the aid of altitude correction computers, the true altitude may be obtained. This is especially important when the aircraft is performing a photographic or bombing mission, or where navigation problems are to be solved involving the use of air speed.

67. Description.—*a.* The vapor pressure thermometer consists of three units, the indicator which is mounted on the instrument panel, the bulb which is located at the point of temperature measurement, and the capillary tube which serves to connect the indicator with the bulb. The ranges of these instruments vary with their particular use and in general fall in the following classification:

- (1) Oil thermometers, 0° to 100° C.
- (2) Coolant thermometers, 0° to 200° C.
- (3) Oil and coolant combination thermometers, 10° to 150° C. (fig. 25).
- (4) Free air thermometer, -40° to +50° C. (fig. 26).

b. The indicator consists of a conventional type Bourdon tube mechanism placed in a 1 $\frac{7}{8}$ -inch bakelite case with a raintight seal. The instrument case is provided with an individual 3-volt light with the receptacle molded integral with the case. Each Bourdon tube is provided with a progressive restrainer to permit the use of a uniformly graduated scale because vapor pressure does not increase uniformly with temperature.

c. The bulb is a hollow brass cylinder about $\frac{1}{2}$ -inch outside diameter by 4 inches long. It contains a volatile liquid (usually methyl chloride) which actuates the instrument. The bulb of the free air thermometer is longer and formed in the shape of a helical tube in order to provide more surface for the air to contact.

d. The capillary tube enters directly into the stationary end of the Bourdon tube. It consists of a very small annealed copper tubing and is protected with braided copper wire armor throughout its length. In order to meet all requirements, the free air thermometers are provided with various lengths of capillary tubing, ranging from 5 to 34 feet. At each end of the capillary special reinforcing armor is placed around the tube to prevent breaking or kinking.

68. Operation.—The operation of a vapor pressure thermometer is entirely automatic. The indicator, capillary, and bulb are integral with each other as shown in figure 27. As the temperature of the bulb increases the liquid inside the bulb, being highly volatile, is changed into a gas. This change of state causes an increase in pressure which is transmitted through the capillary tubing to the Bour-

don tube *b*. The Bourdon tube tends to straighten out and this movement is transmitted through a linkage to the sector *c* which rotates around its fixed pivot. The teeth of the sector are meshed

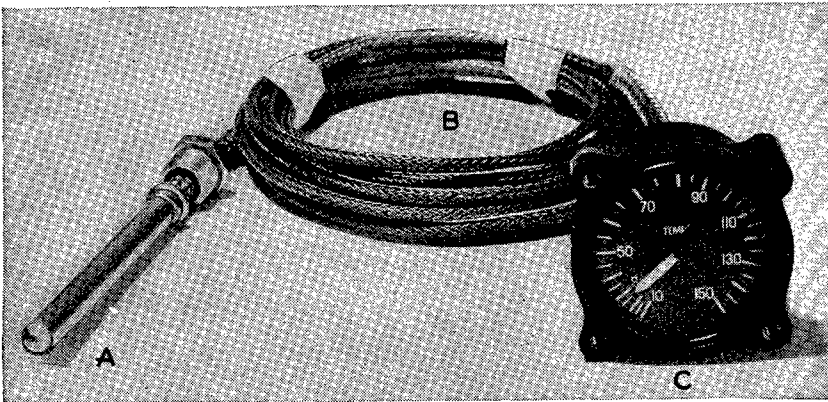

A. Bulb. B. Capillary. C. Indicator.

FIGURE 25.—Oil and coolant thermometer.

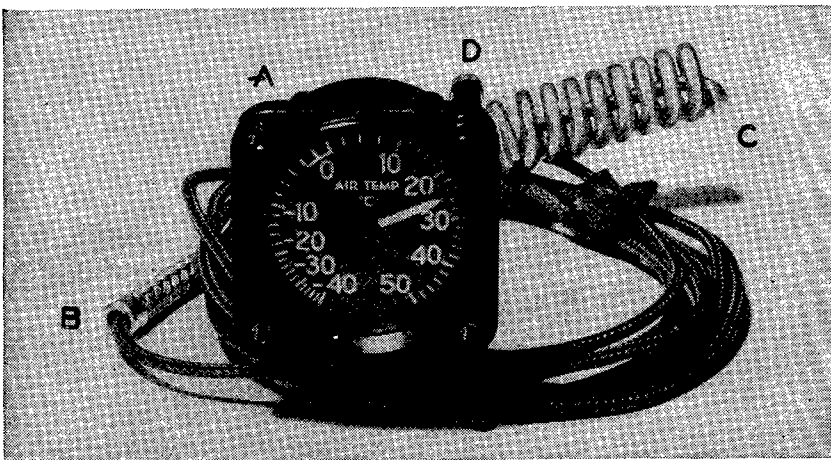

A. Indicator. C. Bulb.
B. Capillary. D. Lamp.

FIGURE 26.—Free air thermometer.

with a pinion on the pointer shaft which also rotates around a fixed axis and shifts the pointer *a* to various positions with reference to the graduations on the scale. Since the vapor pressure does not increase uniformly and because a uniform scale is most desirable in instruments of this type, the actual movements of the Bourdon tube are controlled by a progressive restrainer.

69. Installation.—*a.* In addition to the general points on installation covered in section III, some specific instructions should be considered for the vapor pressure thermometers. The units of these thermometers are integral and cannot be separated without a total loss of the assembly. Particular care is to be taken of the capillaries which should not be cut, broken, dented, or mashed, stretched or pulled taut. They are protected with friction tape shellacked on at all points of contact with other surfaces, and must not come in contact with exhaust stacks or other excessively hot parts of the engine.

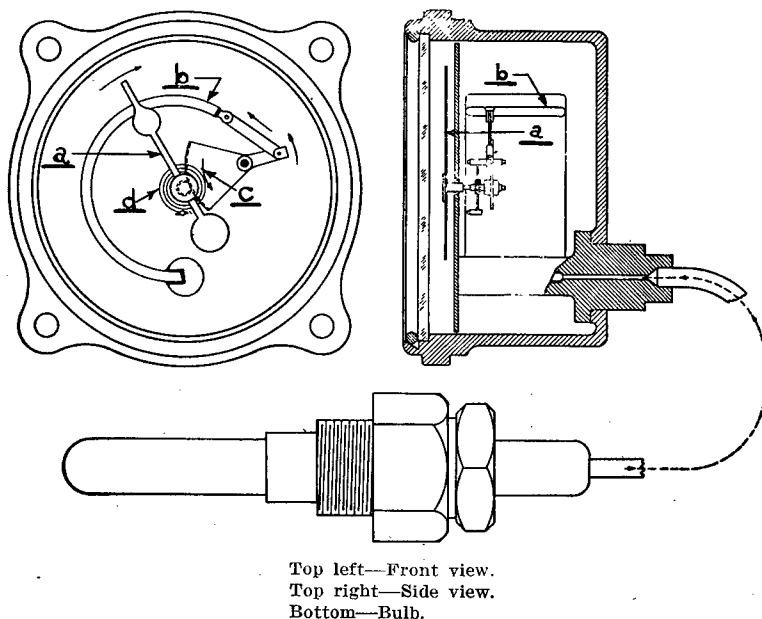

FIGURE 27.—Vapor pressure thermometer mechanism.

When replacements are made, longer capillaries may be used if the correct lengths are not available, provided the excess is neatly coiled and taped to some structural part of the nacelle or fuselage.

b. When installing free air thermometers on single-engine airplanes, it is desirable insofar as possible to install the capillary tubing inside the wing in an aluminum conduit, preferably near the leading edge in such a manner as to facilitate replacement of defective instruments by service activities without removal of the wing. This prevents the capillary tubing from disturbing the air flow over the wing as has been experienced when external installations have been made along the leading edge of the wing.

c. Where inside installations cannot be made, the capillary tubing should be securely fastened along the trailing edge of the wing and where wing strut installations outside the slip stream are not feasible, the coil or bulb is installed beyond the slip stream in a fore and aft direction attached to the rear spar and preferably on the lower side of the wing. If for any reason the tube must be placed along a spar, care must be taken that the spar flange and stiffeners are not drilled for attaching the fittings. If the airplane is equipped with flaps the capillary tubes should lie just even with the trailing edge of the wing and clear of the flaps. In any case on external installations the capillary tubing must be fastened at sufficient points to prevent whipping.

d. On two-engine airplanes, the coil or bulb is conveniently located on the outside of the fuselage.

70. Maintenance.—General information on maintenance of vapor pressure thermometers is contained in section II. In addition, each installed thermometer must be properly labeled, using name plates or aircraft enamel to indicated its use as listed below.

- a.* (1) Free air temperature.
- (2) Carburetor air temperature.
- (3) Carburetor mixture temperature.
- (4) Cabin air temperature.
- b.* (1) Oil in temperature.
- (2) Oil out temperature.
- c.* (1) Water temperature.
- (2) Prestone temperature.
- d.* (1) Cylinder head temperature.
- (2) Cylinder base temperature.

SECTION XVI

ELECTRICALLY OPERATED THERMOMETERS

	Paragraph
Purpose and use.....	71
Description.....	72
Operation.....	73
Installation.....	74
Maintenance.....	75

71. Purpose and use.—The uses of electrically operated thermometers are the same as for vapor pressure thermometers as given in paragraph 66.

72. Description.—*a.* The electrically operated thermometer consists of three main parts, the indicating instrument, the temperature sensitive element (bulb), and the connecting lead wires between the

indicating instrument and the bulb. The ranges of the various electrically operated thermometers depend on their particular use and in general may be classified as follows:

- (1) Oil temperature thermometers, 0° to 100° C. and 20° to 120° C.
- (2) Fuel mixture thermometers, -10° to +50° C.

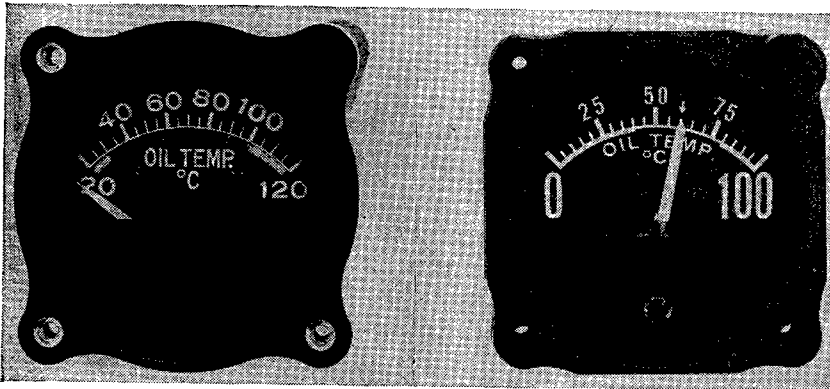

① Oil thermometer (20° to 120°).

② Oil thermometer (0° to 100°).

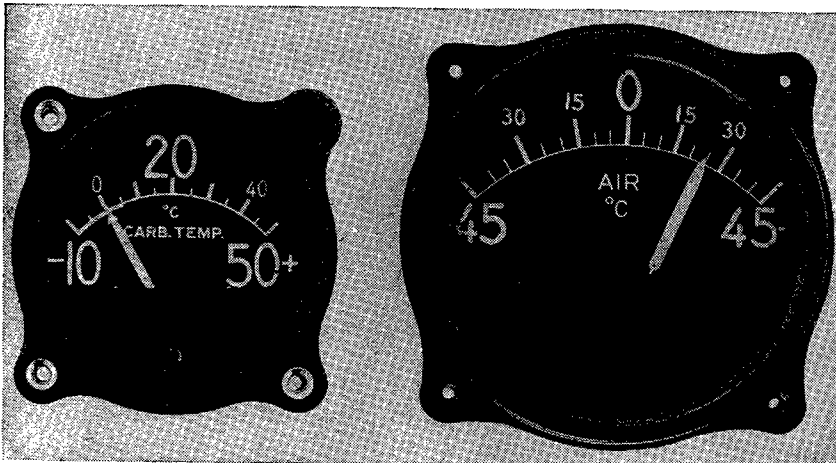

③ Fuel mixture thermometer.

④ Free air thermometer.

FIGURE 28.—Electrically operated thermometers.

(3) Free air thermometers, -45° to +45° C. Typical electrically operated thermometers for temperature measurement of oil, fuel mixture, and free air are shown in figure 28. The oil and fuel mixture thermometers have 1 7/8-inch dials, while the free air thermometer is housed in a case with a 2 3/4-inch dial.

b. Electrically operated thermometer indicators are of two general types: those having a sensitive D'Arsonval mechanism and those having a ratio meter mechanism.

(1) The indicators of the first type have a permanent magnet and a moving coil. This coil carries an aluminum radium-treated pointer and two phosphor bronze springs, and is equipped with two steel pivots. The pivots are ground so as to have a slight roundness at their point in order to withstand the vibration encountered in aircraft. This assembly is arranged to rotate in sapphire bearings which are mounted in screws secured by means of lock nuts and arranged to allow adjustment of end play of the coil. The instrument mechanism is

ARMS A, B, C = 100 OHMS EACH

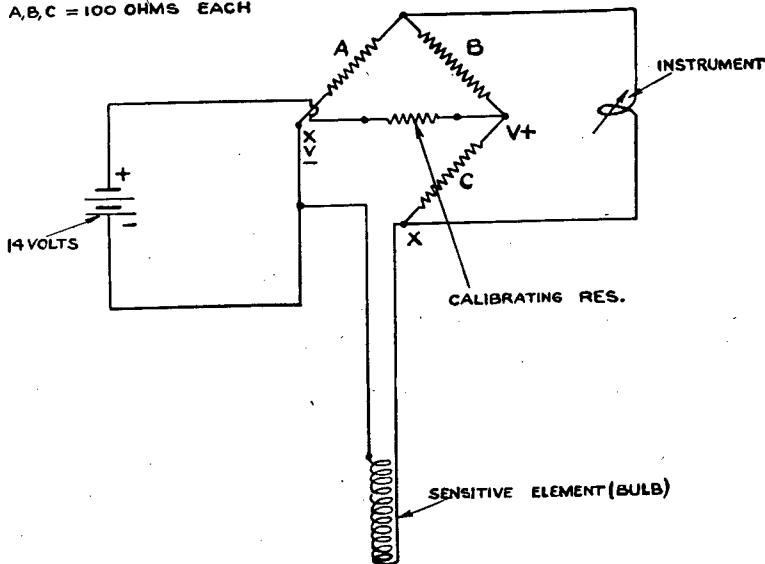

FIGURE 29.—Wiring diagram of electrically operated thermometer.

mounted on a bakelite backplate and housed in a bakelite case over which a soft iron shield is placed to minimize the effect on the magnetic compass. Mounted on the backplate are three spools which are wound with manganin wire to have a resistance of 100 ohms each. These spools are connected to form three arms of a bridge designated as A, B, and C in figure 29, the fourth arm being the sensitive element (bulb). The instrument mechanism is connected across two opposite corners of the bridge and the source of current supply is connected across the two remaining corners, the instrument mechanism serving as the galvanometer. On the back of the instrument three connections are brought out in a bakelite block for the purpose of connecting the indicator to the sensitive bulb and to the source of current supply. Over

the terminals is also a static shield arranged to take standard shielding material for shielding the conductors in order to prevent any interference with radio. The indicators of the later types of these thermometers are provided with an individual 3-volt light, the receptacle being molded integral with the case.

(2) The principal feature of the ratio meter type indicator is that its accuracy is maintained independent of voltage variations. The mechanism of the ratio meter type thermometer has both a magnetic and coil system as shown in figure 30. The magnet is a heavy alloy steel structure which is mounted on a bracket which also holds the pole pieces. The pole pieces and core are both circular but the relation between the core and the pole pieces is one of eccentricity, that is, the core is set above the center. The moving coil consists of two individual coils cemented together. The common terminals, which are connected together and are for temperature measurement purposes, are brought out as a common connection to the batteries. One coil is connected through a manganin resistance and back to the battery, thus carrying a current proportional to the voltage and resistance. The other coil is connected through the resistance bulb and back to the battery.

c. The temperature sensitive element or bulb (fig. 31), made up of a winding of specially selected pure nickel wire wound on an anode-treated aluminum tube, changes its resistance with temperature and is adjusted to be exactly 100 ohms when subjected to a temperature of 0° C. The protection tube is made up of monel which is silver-soldered into a hexagon head. The two ends of the nickel winding are soldered to a twin plug connector, which is made of bakelite having molded into it two silver-plated brass female inserts arranged to receive a bakelite two-prong plug with silver-plated brass split pins. In addition, an adapter which is designed to cover the connecting plug is also threaded to receive the nut on the end of the static shield over the conductors. A gasket is provided between the adapter and the hexagon head in order to seal against moisture. In the case of the free air thermometer, the resistance bulb is placed in a specially designed housing for attachment to the skin of the fuselage or wing.

73. Operation.—*a.* The operation of electric thermometers is dependent upon the current supply. The source of this supply is the battery generator system of the airplane which is turned “off” and “on” by use of individual control switches or a single master switch.

b. The D'Arsonval system (fig. 29) is essentially an unbalanced Wheatstone bridge. The bulb or sensitive element is installed at the point where the temperature is to be measured. For every temperature the bulb will have a definite resistance proportionate to that

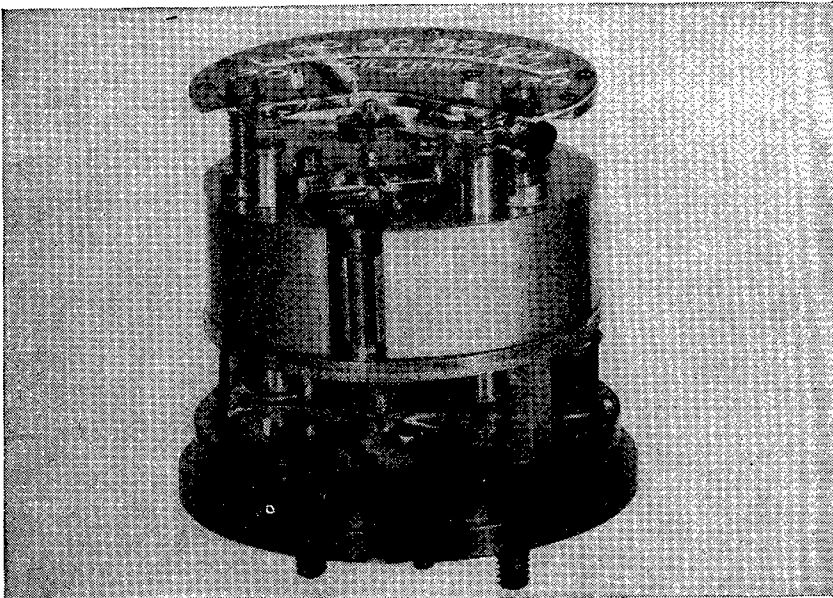

① Side view.

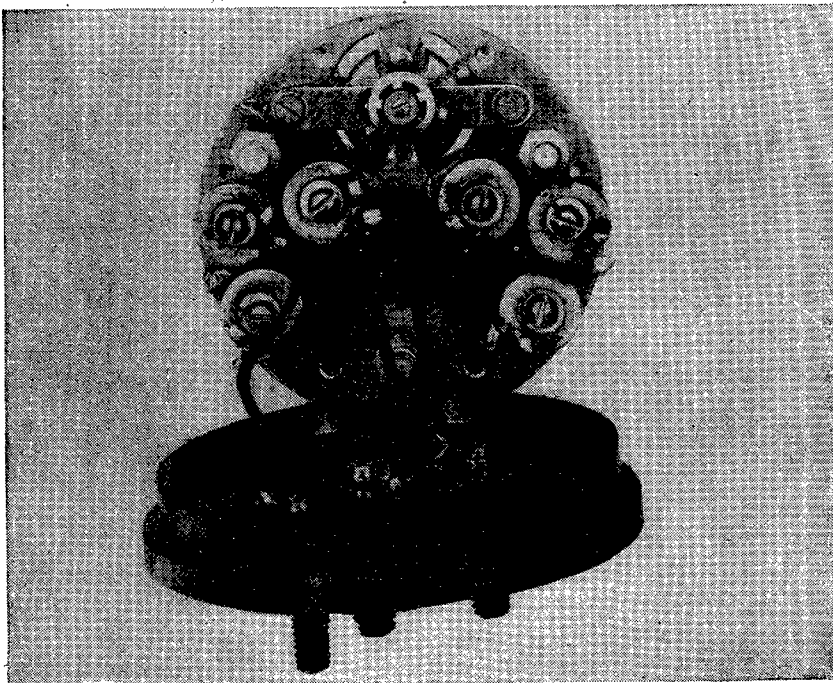

② Rear view.

FIGURE 30.—Ratio type thermometer internal mechanism.

temperature, and the bridge of which the bulb forms one arm will assume an unbalanced condition in a direction and in magnitude corresponding to the particular temperature to which the bulb is

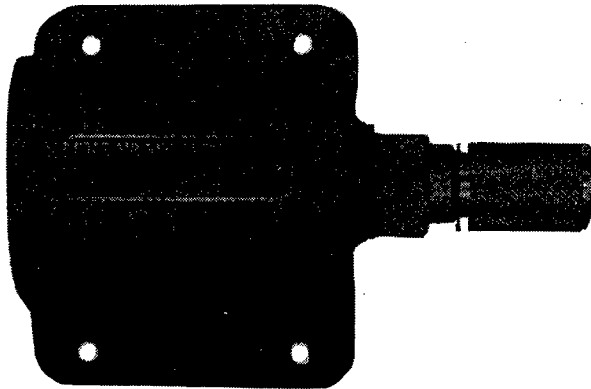

① Free air thermometer bulb.



② Oil or fuel mixture thermometer bulb.

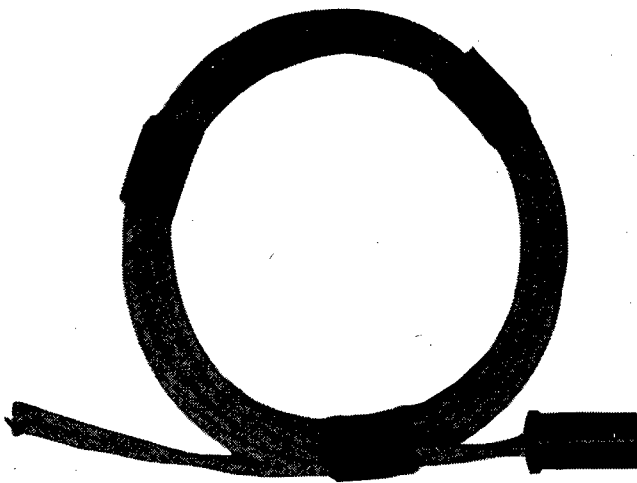

③ Connecting lead.

FIGURE 31.—Resistance bulbs and lead.

exposed. The indicator acts as the galvanometer in the Wheatstone bridge circuit, and the pointer deflection will indicate temperature in accordance with the unbalanced condition of the bridge. When the sensitive element is exposed to a temperature of 0° C., its resistance will be 100 ohms and since the arms *A*, *B*, and *C* are 100 ohms

each, it follows that under this condition the bridge is balanced. The indicating instrument will then have no current flowing through its moving coil and will therefore be in its normal zero position. When the sensitive element is exposed to a temperature higher than 0° C., its resistance will increase, thereby unbalancing the bridge in a direction which causes the indicating pointer of the instrument to deflect toward the right, thus indicating the increase in temperature. Likewise when the temperature sensitive bulb is exposed to a temperature lower than 0° C., the bridge will be unbalanced in a direction which causes the pointer to deflect toward the left part of the scale, thereby indicating a temperature lower than 0° C.

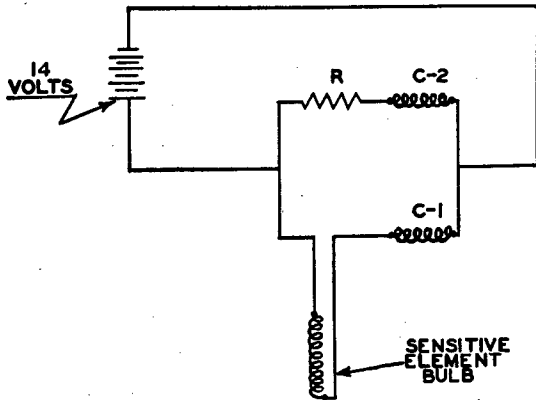

FIGURE 32.—Wiring diagram of ratio type thermometer.

c. The ratio meter type system consists of a circuit having two parallel branches as shown in figure 32. One has a fixed resistance in series with the coil *C-2* and the other the resistance bulb in series with the coil *C-1*. The direction of current in each coil and the polarity of the magnet is such as to cause the coil carrying the greater current to move into the weaker field. When the resistance of the bulb is identical with the manganin resistance *R*, and the same value of current is flowing through each coil, the torques balance and the pointer remains in the vertical position. If the temperature of the resistance bulb is raised, its resistance is increased and the current through the movable coil *C-1* is reduced. The torque of this coil is reduced as a result and the other coil *C-2* pushes downward into a weaker field, whereas coil *C-1* with its lower current goes into a stronger field and the torques again balance due to the differences in field strength at these new positions. The pointer will

therefore move across the scale to the new position, which is calibrated in terms of temperature of the bulb. By the same token, a reduction in temperature of the bulb would increase the current through coil *C*-1 and cause the pointer to move to the left. At a definite value of temperature and hence definite bulb resistance, the instrument reading is independent of comparatively large variations of battery voltage as the position taken by the pointer depends only upon the ratio of current of the two coils.

74. Installation.—*a.* The general points on installation of instruments as discussed in section III apply to these thermometers. After unpacking the indicators, they should be inspected to make sure that the glass is not cracked or broken, care being taken that when the instrument is rotated gently the pointer swings freely. The bulbs should be examined to see that no parts of the connecting head are missing.

b. When connecting the wires to the bulb leading to the instrument, the insulation is removed for about $\frac{1}{4}$ inch on the ends of the wires and the wires scraped clean. The wires are then connected to the bulb by removing the adapter and exposing the bayonet plug. The bayonet plug may then be pulled out from the bulb proper. The wires are slipped through the hole in the adapter and secured to the plug. The plug is then replaced into the bulb and the adapter put back in position.

c. Figure 33 shows two wiring diagrams. Figure 33① is a grounded system, while ② is insulated from the ground. Their functions, however, are identical. To take off the static shield the four hexagon nuts and lock washers in the back of the instrument are removed, after which the cover can be removed and the shield will slide off exposing the terminal block. One wire leading from the bulb is connected to the binding post marked *X*, the other wire from the bulb being connected to the frame of the airplane as shown in figure 33① or to the terminal marked *XV* as shown in figure 33②. After connecting the wires to the instrument, the static shield and cover fitting are replaced over the terminal opening and secured by means of the hexagon nuts and lock washers.

d. Before turning on the battery current, make sure that the instrument is on its normal zero which is 0° C. If it is found that the instrument is not on zero, adjust to zero by means of the small screw on the front of the instrument. By means of a small screw driver, rotate the screw slowly toward right or left until the instrument is on zero and then turn on the current.

75. Maintenance.—*a.* The general points on maintenance of instruments given in section II apply to these thermometers. In checking for and adjusting the mechanical zero it should be ascertained that the current to the instrument is off.

b. No servicing of the bulb is required. Unless the bulb is damaged by excessive heat, it should function indefinitely. The bulb will withstand for a short period temperatures of 302° C. (575° F.) but temperatures in excess of this may seriously damage the bulb and make it inoperative. In that case, it must be replaced with a new one and the old one forwarded to the depot for repair. Before condemning

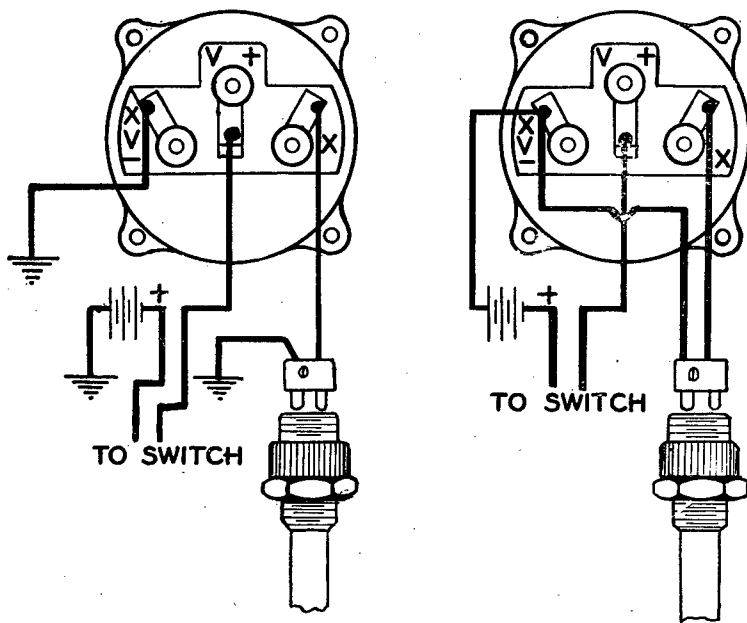

① Grounded system.

② Insulated from ground.

FIGURE 33.—Installation diagram of electrically operated thermometer.

or reporting either the indicator or bulb as being unserviceable, a careful check should be made to insure that the apparent failure is not due to loose or shorted connections especially at the bulb end.

c. When service maintenance necessitates replacement of electric thermometer units, part numbers must be checked carefully in order to match bulbs and indicators. For further information on the interchangeability of the electric thermometer units reference is made to tables in Air Corps Technical Orders.

SECTION XVII

CYLINDER TEMPERATURE GAGES

	Paragraph
Purpose and use.....	76
Description.....	77
Operation.....	78
Installation.....	79
Maintenance.....	80

76. Purpose and use.—The purpose of cylinder temperature gages on airplanes is to measure and indicate the temperature of air-cooled engines at some point on one of the cylinders, usually the master rod cylinder.

77. Description.—*a.* The cylinder temperature thermometer consists essentially of an indicator, thermocouple, and the thermocouple leads. If more than one thermocouple is used, a multiple polar switch is employed for connecting the various thermocouples to the indicator as required.

b. The indicator is a sensitive D'Arsonval type mechanism having a coil arranged to move in an annular air gap of a permanent magnet.

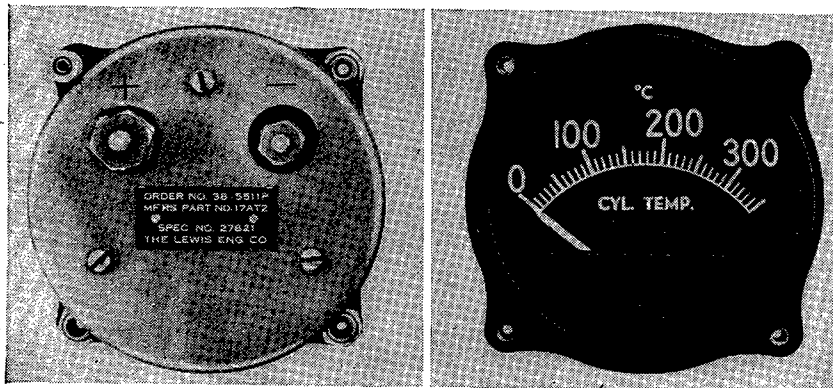

① Rear view.

② Front view.

FIGURE 34.—Cylinder temperature gage.

The coil carries the pointer and the control consists of two phosphor bronze springs which also serve to conduct the current into the coil. This mechanism is placed in a 2¾-inch molded bakelite case which is provided with a raintight seal and is covered with a static shield. Two binding posts protrude from the rear of the case and are marked with positive and negative signs, as shown in figure 34①. Standard temperature gages are provided with a 3-volt light, the receptacle being integral with the instrument case. The indicator as shown in

figure 34② has a range of 0 to 350° C. and is suitably calibrated and adjusted for use with iron constantin thermocouples and leads. It is adjusted to allow for an external circuit resistance of 2.00 ohms, which includes the thermocouple and leads, these always having the same value of resistance.

c. The thermocouple and thermocouple leads (fig. 35) are made of iron and constantin, the latter being an alloy of copper and nickel. They are selected so as to have a definite electromotive force per degree of temperature. The thermocouple consists of a solid copper gasket with the two extensions brazed to its surface. The gasket is the same

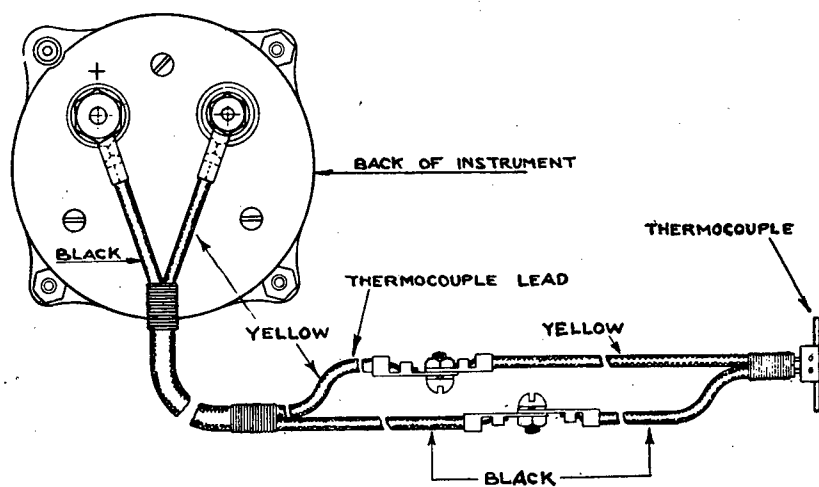

FIGURE 35.—Diagram showing connection of cylinder temperature gage, thermocouple, and leads.

in dimensions and is interchangeable with standard spark plug gaskets. The leads are insulated and have suitable terminals for connection at both ends. Switch leads, if used, are normally so short that their resistance is negligible and can be ignored.

78. Operation.—*a.* The operation of this thermometer depends on the fact that when two dissimilar wires are joined together to form a junction (generally called the hot junction) and the junction is heated, an electromotive force will be generated at the opposite ends of the two wires (generally called the cold junction). The magnitude of this electromotive force depends upon the difference in temperature between the hot and the cold junction and upon the composition of the metals used.

b. As the electromotive force generated depends upon the difference in temperature between the hot junction (the spark plug thermocouple washer) and the cold junction (the cold junction extends inside of the

instrument case), it follows that in order to indicate the true temperature at the spark plug some means must be employed to compensate the indicator for cold junction temperature changes. This is done by means of a bimetallic spiral spring, the outer end of which is attached to one of the control springs of the instrument. This causes the instrument to be actuated not only by the voltage of the thermocouple, but also by the temperature surrounding the instrument itself. When the thermocouple lead is disconnected from the instrument, the instrument will indicate the temperature of the location where it is installed. A negative temperature coefficient resistor is included in series with the moving coil of the instrument to compensate for the positive temperature coefficient of the moving coil.

79. Installation.—*a.* The general points on installation of instruments given in section III apply to the cylinder temperature gage. In addition, some specific points must be observed when service maintenance necessitates replacement installation. The binding posts of the indicator are short-circuited by a small piece of copper wire to close the electrical circuit for protection during shipment. This should be taken off and discarded at the time of installation. The magnetic shield must not be removed as this would influence the magnetic system and cause an error in the readings. Sometimes a non-magnetic static shield and cable connector is also supplied. This will be found mounted on the rear of the magnetic shield covering the binding posts. This static shield should be loosened when connecting leads to binding posts. However, it has no influence on the readings or accuracy of the indicator and is used only to prevent interference with the radio equipment and the magnetic compass.

b. In making the installation, all connections should be clean and tight, otherwise resistance will be introduced and the readings incorrect. After the gasket thermocouple has been secured in position under the spark plug and connections made to the leads, the connectors should be anchored in some way either by insulation tape or by a small clamp to prevent breaking due to vibration. In any event, the connectors must be taped to prevent shorting to the engine. The thermocouple lead is attached to the thermocouple at the one end and the indicator at the other end. The indicator end of the lead has two eye terminals with holes of unlike diameter; the thermocouple end of the lead has one eye terminal and one terminal with a nut mounted on it. The plus and minus studs of the indicator are of unlike diameter, and the indicator studs and lead terminals are so arranged that connections can be made in one way only. Correct polarity is thus assured.

c. The thermocouple leads must not be lengthened or shortened as they are of a definite resistance and enter into the calibration of the indicator. When installing, it is often desirable to trace out thermocouple leads from the engine end. A convenient method of doing this is to use a spare thermocouple attaching it to the lead to be traced and then heating the couple with a soldering iron. In this way, enough voltage will be generated to obtain a reading on the indicator.

80. Maintenance.—The general points on maintenance given in section II are applicable to cylinder temperature gages. In checking the indicator for its zero position, one convenient method is to open the circuit at some point, for example, at the thermocouple, or by removing one of the eye terminals from one of the studs on the back of the indicator. The instrument should then indicate the temperature of the cockpit which can be checked by placing a mercury in-glass thermometer adjacent to the indicator allowing sufficient time for the mercury thermometer to attain this temperature. The zero position of the indicator can then be adjusted to agree with the thermometer reading by rotating the zero adjusting screw located on the glass face.

SECTION XVIII

FUEL MIXTURE INDICATORS

	Paragraph
Purpose and use.....	81
Description	82
Operation	83
Installation	84
Maintenance	85

81. Purpose and use.—*a.* The fuel mixture indicator (exhaust gas analyzer) is an instrument that indicates fuel-air ratio of the mixture entering the engine.

b. The instrument is used as a guide to the pilot in setting the mixture control. Heretofore with fixed pitch propellers a method was used for setting the mixture control which was based on the falling off of engine rpm as the mixture was leaned or enriched. With the use of constant speed propellers, another method of indicating the mixture became necessary since the rpm is not affected even when the mixture is lean enough to damage the engine or rich enough to cause excessive fuel consumption.

82. Description.—*a.* Fuel mixture indicators are of two general types, those for single-engine airplanes and those for dual-engine

airplanes. Although the construction features of the two are different, their principle of operation is exactly the same.

(1) The fuel mixture indicator for single-engine airplanes (fig. 36) consists of an analysis cell and an indicator unit. The indicator unit includes the galvanometer for indicating the fuel-air ratio, a ballast

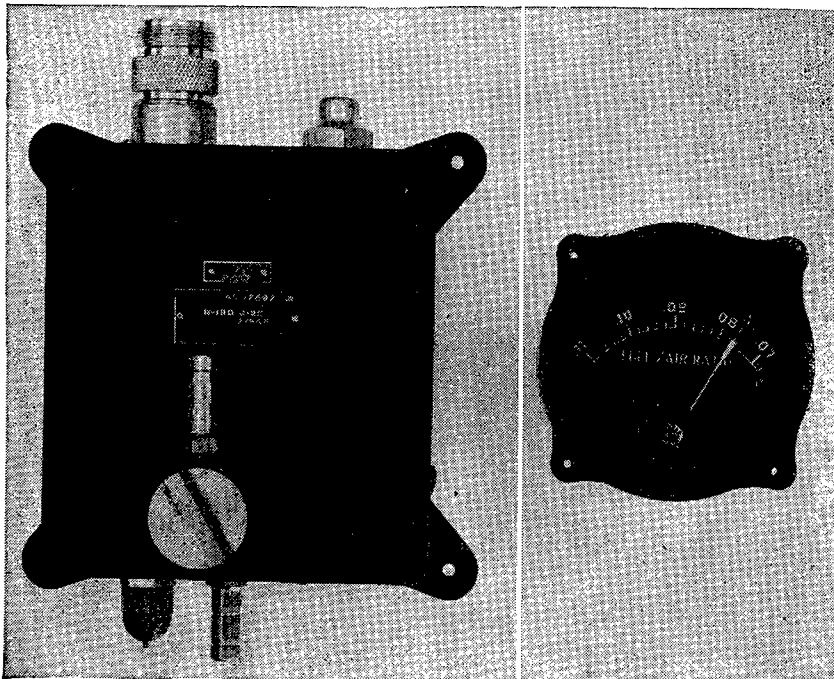

ⓐ Analysis cell.

ⓑ Indicator unit.

FIGURE 36.—Fuel mixture indicator for a single engine (Breeze).

tube for maintaining a substantially constant current through the bridge, a lamp for proper illumination of the scale together with a lamp series resistor, and the necessary coils and resistances, plug and sockets, etc., for making connections to the other units of the assembly. The analysis cell consists of a filter for removing the carbon particles from the exhaust, filled with replaceable stainless steel wool, which is connected by a small opening to the analysis cell proper. In this are four small cells across each of which is stretched a fine platinum resistance wire. Two of these cells are sealed with moistened air (moisture provided by a removable wick) and the other two are connected through the filter to the exhaust gases. The four cells form the legs of a resistance bridge (Wheatstone bridge) across which a galvanometer type indicator is connected. Figure 37 is a

wiring diagram of the fuel mixture indicator for the single-engine airplane showing the internal connections of the units. The two legs of the Wheatstone bridge in the analysis cell that are exposed to the exhaust gases are marked "EXP." Also shown are the connections to the various series and shunt resistances, galvanometer, ballast tube, and source of current supply.

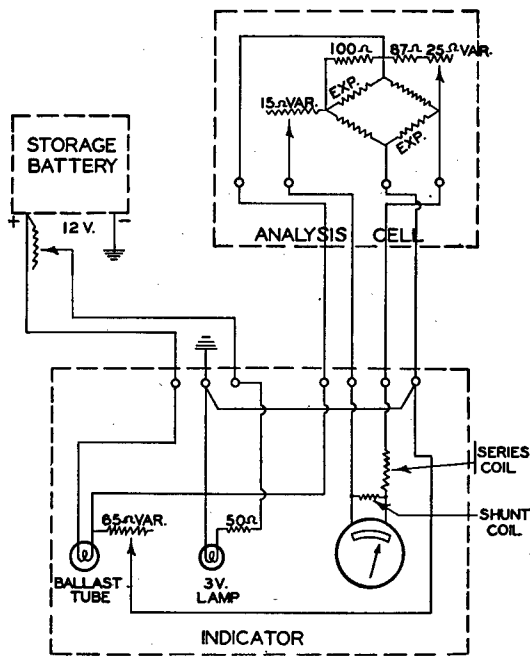
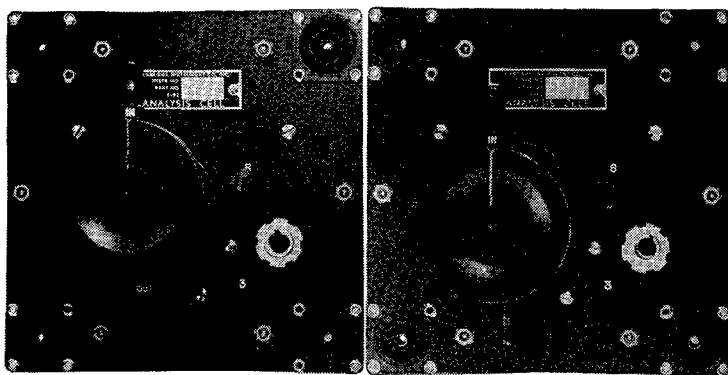

FIGURE 37.—Fuel mixture indicator wiring diagram for a single engine (Cambridge).

(2) The component parts of the dual-engine fuel mixture indicator system are shown in figure 38 and consist of two analysis cells, one for each engine, an indicator unit, and a junction box. The analysis cells for this installation are similar to that described for the single-engine airplane and includes the brass block or resistance thermometers for the analysis of the exhaust gas, necessary resistors for completing the bridge circuit, and filter chamber for filtering the carbon particles from the exhaust. The indicator unit contains two galvanometers to each of which is attached a pointer. Both pointers move over a single dial having an upper and a lower scale for indicating the fuel-air ratio of both engines. The junction box unit includes the ballast tube, a switch, a rheostat, two resistance units, and a panel for connections.

b. Multiple conductor shielded cable with conventional type terminals is used to connect the various units. A current supply of from



① Analysis cell (left engine). ② Analysis cell (right engine).

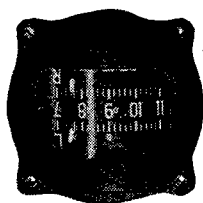

③ Indicator unit.

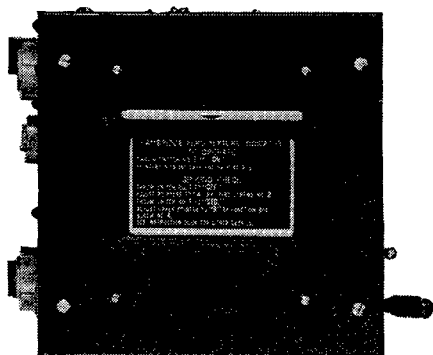

④ Junction box.

FIGURE 38.—Fuel mixture indicator for dual engines (Cambridge).

11.5 to 15 volts from the battery circuit in the airplane is used to energize the electrical system of the unit. This is reduced to 4.1 volts by the ballast tube and variable resistances in the circuit because the indication could be accurate only on a constant voltage.

83. Operation.—*a.* The engine exhaust is composed of several gases, carbon dioxide (CO_2), carbon monoxide (CO), oxygen (O_2), hydrogen (H_2), and nitrogen (N_2). The proportion of these gases in

the exhaust varies and depends upon the fuel-air ratio of the fuel mixture supplied to the combustion chambers by the carburetor. This relationship is definite; consequently, an instrument which will respond to changes in the proportion of certain of the gases can be used readily to indicate the fuel-air ratio of the fuel mixture.

b. A rich mixture (more fuel and less air than normal) results in an increase in H_2 and a decrease in CO_2 and a lean mixture reverses the proportion. H_2 has a thermal conductivity about six times greater than air, while that of CO_2 is approximately one-half that of air. It is on this difference in thermal conductivity of the two gases and their varying proportions in the exhaust that the operation of the instrument is based. The proportion of the other gases varies also but their thermal conductivity is considered as being about equal to that of air as far as it concerns the operation of the instrument.

c. The sampling tubes continuously collect and dispose of gas samples. The gas is collected and brought into the analysis cell block. The cell block contains the Wheatstone bridge which is in electrical balance at $0^\circ C.$ with no exhaust gases present. The two diametrically opposed branches of the Wheatstone bridge are placed in the path of the sample gas which must flow around the two exposed branches or resistors. The other two diametrically opposed branches of the Wheatstone bridge are sealed in a chamber exposed to moisture saturated air. Exhaust gases are completely sealed off from these two branches or resistors of the Wheatstone bridge.

d. The voltage energizing the Wheatstone bridge is reduced to 4.1 volts by means of a ballast tube. This is merely a resistor sealed in a hydrogen filled glass bulb which reduces to a minimum the influence of outside temperature, pressure, and altitude on the resistor. Any variation in current to the fuel mixture indicator instrument is reduced to such small proportion by the ballast tube as to be negligible. The current stabilizes the temperature of the branches of the Wheatstone bridge (or resistors) at $260^\circ F.$ As the exhaust gases flow around the two exposed cells of the resistors, heat will be carried off by the sample of exhaust gas passing the cell. The amount of heat carried off depends upon the proportion of H_2 and CO_2 in the volume of the gas.

e. A greater proportion of the volume of H_2 gas carries the heat away from the cells or resistors more rapidly. This cools and lessens the resistance of the resistor and causes the indicator needle to indicate a richer mixture. The movement of the needle is directly in proportion to the increase of H_2 gas. A greater proportion of CO_2 gas and a decrease of H_2 gas around the cells or resistors will carry

off heat less rapidly. The increased temperature of the resistor results in increased resistance causing the needle to deflect to the lean indication.

f. There is one important exception to the normal operation as described. If the mixture is leaned to a point where detonation (explosive combustion of the mixture within the cylinder) occurs, high proportions of H_2 are liberated causing the pointer to swing to the rich side. If this indication is misunderstood and the mixture leaned further, the extent of the detonation will increase and a still richer indication will be shown. If properly understood, this characteristic can be used successfully as a warning of detonation which is quite dangerous and if allowed to continue can result in total engine failure. Slight detonation is indicated by a fluctuation of the pointer.

g. The instrument is automatically in operation when engine is started. When making adjustments of the mixture, approximately 1 minute must be allowed before reading the indicator, as this period of time is required before a change in the carbon dioxide and hydrogen content of the exhaust gases will be indicated. The instrument will accurately indicate values of fuel-air ratios from 0.068 to 0.110, provided there is no detonation present. As the mixture is leaned out if the indicating needle does not show a leaner mixture or backs up the scale toward the rich side, detonation has very likely been encountered and the mixture should be enriched.

h. It is not expected that the fuel-air ratio indicator will supplant the engine cylinder thermometer in the avoidance of engine overheating. As there may be conditions which would cause overheating with normal indications of the fuel-air ratio indicator, both instruments should be watched and, if necessary, the mixture enriched from the recommended settings in order to prevent overheating. If the pointer stays at the center of the scale near the "A" (air-point) position, it may be that the sampling line from the exhaust stack to the analyzing cell is broken.

i. When carburetor air heaters are used, the mixture indication very definitely goes rich and if prolonged running is to be done while using the air heater, the mixture should be reset after applying the heat. Likewise when heat is shut off the pointer will definitely show lean. Therefore when shutting off the carburetor air heater always enrich the mixture first.

84. Installation.—*a.* General information on installation of instruments is given in section III and specific installation instructions can be obtained from installation drawings for the particular airplane

AIRCRAFT INSTRUMENTS

on which this equipment is to be installed. A typical dual-engine installation is shown in figure 39.

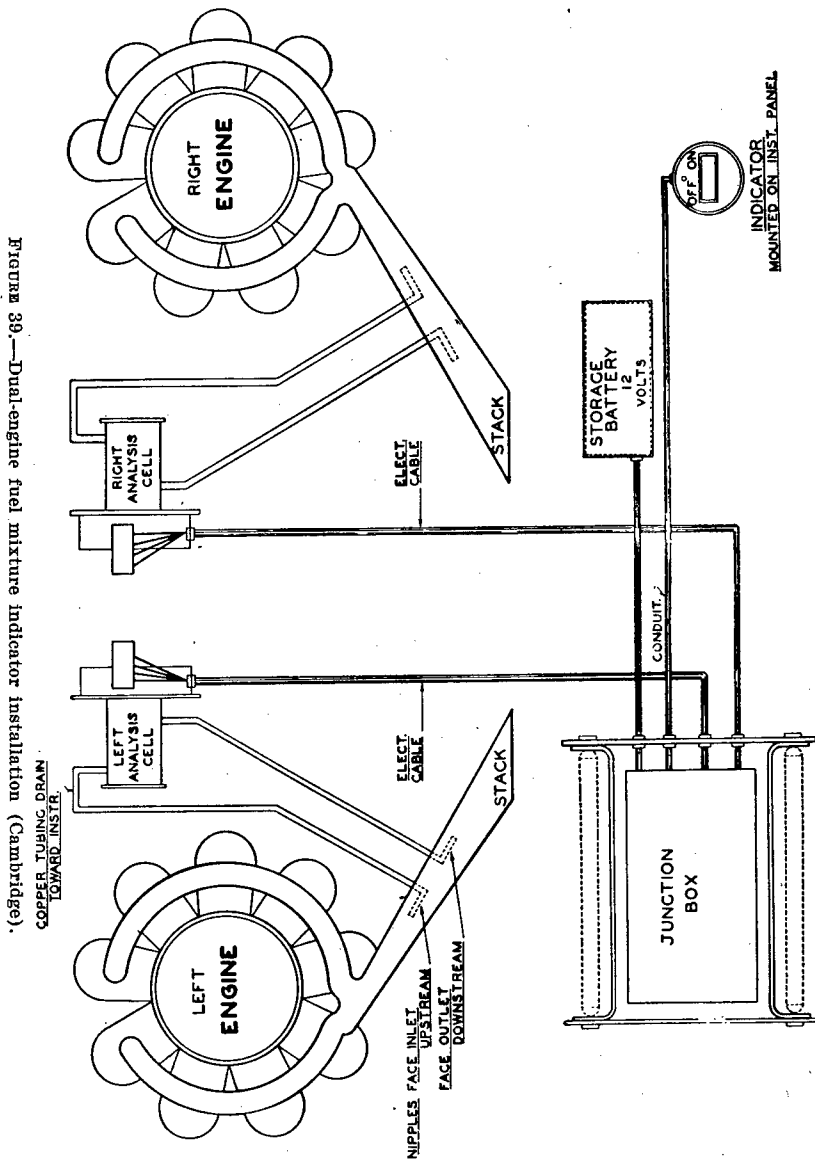

Figure 39.—Dual-engine fuel mixture indicator installation (Cambridge).

b. The indicator is installed on the panel from the rear. It may be easily removed for replacement when necessary. Each engine requires

two identical sampling tubes and one analysis cell assembly. The inlet sampling tube must be installed as far downstream from the last port as will insure an average sample from all the cylinders. The opening faces so as best to catch the exhaust gases. The outlet sample tube must be from 8 to 12 inches downstream from the inlet sampling tube. The analysis cell must be mounted in the nacelle (preferably on the fire wall) upon a surface where the vibrations are at a minimum and the temperature range is between 32° to 125° F. Below 32° F. will freeze the condensate.

c. To avoid accumulation of condensed gases in the analysis cell, the inlet tubing must run upward for a distance of 12 to 18 inches above the analysis cell and then be brought downward to the cell. Likewise the outlet tubing must have a constant downward slope, having no water trap.

85. Maintenance.—*a.* All general points on maintenance given in section II are applicable to this instrument.

b. Specific items on inspection and maintenance are as follows:

(1) To adjust mechanical zero, set the master switch on the airplane in the "off" position and note the alinement of the pointer on the indicator; if it is either to the right or left of the "A" point marked on the scale, turn the small screw which is located on the face of the instrument until the pointer is in alinement. Vibrate the instrument and repeat until the alinement becomes stable.

(2) To check and adjust electrical zero requires a balanced humidity condition in the wick and filter chambers. This condition is accomplished by removing the filter material and temporarily replacing it with a water-saturated cloth. The wick must also be removed and saturated with clean water to insure perfectly balanced conditions. The current is then turned on and after 20 minutes, the position of the pointer on the indicator is checked. It should aline with the "A" point on the scale. If the alinement is not correct, it is an indication of unbalanced resistance. This is corrected by loosening the hex nut on top of the cell and with a screw driver turning the core a slight amount until the pointer on the indicator is in perfect alinement with the "A" point on the scale. The indicator should be vibrated lightly during the actual adjusting operation and extreme care must be exercised when tightening the nut after completing the adjustment not to move the core again. This procedure must be strictly followed step by step, otherwise there is a possibility of doing more damage than good.

(3) To clean the sampling lines and nipples, break the connections at the cell, insert a discarded tachometer shaft into each line, first one then the other, and rotate it several times. It may be necessary to

withdraw and repeat the insertion several times in order to dislodge the condensate and carbon residue.

(4) To service the filter which is located in a tube extension at the bottom of each cell assembly, remove the safety wire and the plug. Then take the filter out and wash in gasoline to remove the oil and carbon residue. Then wash it in clean water, shake thoroughly, and replace it in the tube. If the material is corroded and decomposed to any extent, replace it with a new one.

SECTION XIX

SELF-SYNCHRONOUS INSTRUMENTS

	Paragraph
Purpose and use.....	86
Description.....	87
Operation.....	88
Installation.....	89
Maintenance.....	90

86. Purpose and use.—*a.* Self-synchronous instruments provide a means for measuring engine and airplane functions and transmitting the measurements electrically to a centrally located instrument panel in the pilot's or flight engineer's station in the airplane. Electrical transmission from the various remote points of measurement eliminates the use of rigid and semirigid connections such as tubing, shafts, capillary line, etc. On large multiple engine airplanes, this flexibility of connection is absolutely essential and can be accomplished satisfactorily only by use of electrical transmission systems. The instruments are used in pairs, one unit serving as a transmitted and the other as an indicator. By means of a selector switch it is possible to use one indicator with several transmitters. In this way indications from several engines or tanks may be had with greatly reduced space on the instrument board.

b. Self-synchronous instruments are used to measure and indicate the following airplane engine functions:

- (1) Fuel pressure.
- (2) Oil pressure.
- (3) Manifold pressure.
- (4) Engine rpm.
- (5) Fuel level.
- (6) Fuel flow.
- (7) Oil temperature.
- (8) Tail gear position.
- (9) Landing gear position.

(10) Flap position.

(11) Bomb door position.

87. Description.—*a.* The self-synchronous system consists of the indicator located on the instrument panel, the transmitter located with the mechanical measuring device at the point of measurement, and the leads which connect these two units. Both types of indicators are equipped with a ring light, a small 3-volt lamp removable from the front of the instrument being the source of illumination.



⊙ Front view.

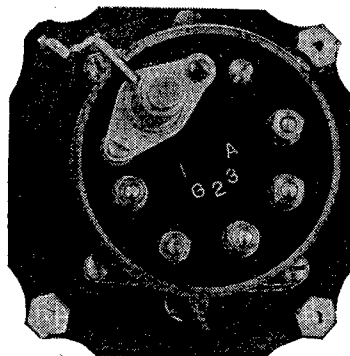

⊙ Rear view.

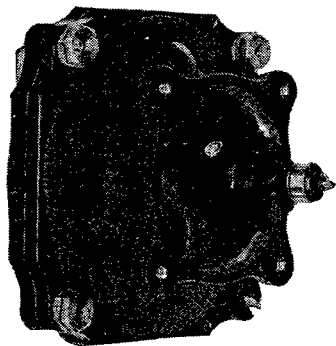

⊙ Rotor.

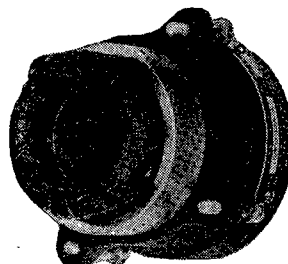

⊙ Stator.

FIGURE 40.—Single pointer self-synchronous indicator.

b. The indicators are of two general types which differ only in construction, the principle of operation being the same. These are the single pointer indicator which is used with one transmitter and the dual pointer indicator which is used with two transmitters, each transmitter operating one of the two indicator pointers.

(1) The single pointer indicator (fig. 40) consists of a motor having a suitable dial and a pointer fastened directly to the motor shaft. It is free to rotate in either direction, there being no stops

or springs of any kind. The motor is a motor only in the sense that its shape and general construction are in many ways similar to the common small power producing motor. It does not, however, spin nor produce power. The two fundamental parts of each motor are the stator and the rotor. The stator is clamped between the two end castings of the motor. Fifteen slots on the inner side of the stator carry a three-phase winding, the three leads of which are connected to the terminals marked "1," "2," and "3" on the motor case. Within the stator, the rotor is free to revolve without stops and is carried in small deep groove ball bearings. The rotor is of the two-pole type and is carried on small precision ball bearings. It has on it a field winding which is energized by 32-volt alternating current from an outside source. One end of the winding is grounded to the rotor shaft and thence through the bearings and an auxiliary silver brush under the dial to the case of the instrument. The other end of the winding is connected to a silver pin protruding from the back end of the rotor shaft and insulated from it. A flat leaf brush located under the bakelite terminal plate makes contact with the pin and connects with the outside terminal marked "A." The ground terminal marked "G" screws directly into the case. These two terminals are connected to the 32-volt power supply. The indicators used for the different functions are alike except for the dial with which they are fitted. The dial for each indicator is graduated over the same range as the mechanical instrument of like kind discussed in various sections.

(2) On the dual pointer indicator (fig. 41), both pointers rotate about the same center and are read on the same dial, each hand having a number to identify the engine with which it is associated. The indicator consists of two separate motors mounted in tandem. Both motors are similar in construction to the motor of the single pointer indicator, each having a stator and a rotor. The rotor shaft of the front motor is hollow and an extension shaft from the back motor passes through it and carries a pointer on its outer end. The extension shaft is carried in jewel bearings and is connected to the rear motor by means of pin and fork coupling so that the two motors can be separated for inspection and repair. The pointer of the forward motor is fixed directly to the end of its rotor shaft. The rotor of each motor is energized by the 32-volt a-c power supply, connection to the rotors being made by means of brushes. One end of each rotor winding is grounded to the shaft by a small spring loaded silver brush on the forward end of each motor. Connection is then made to the terminal "G" on the back of the indicator. The ungrounded end of each rotor winding connects with its respective "A" terminal on the back of the indicator through a brush. The brush of the

back motor is located under the terminal plate and contacts a silver pin projecting from the end of the shaft and insulated from it. The small cylindrical silver brush of the front motor is on the side of the

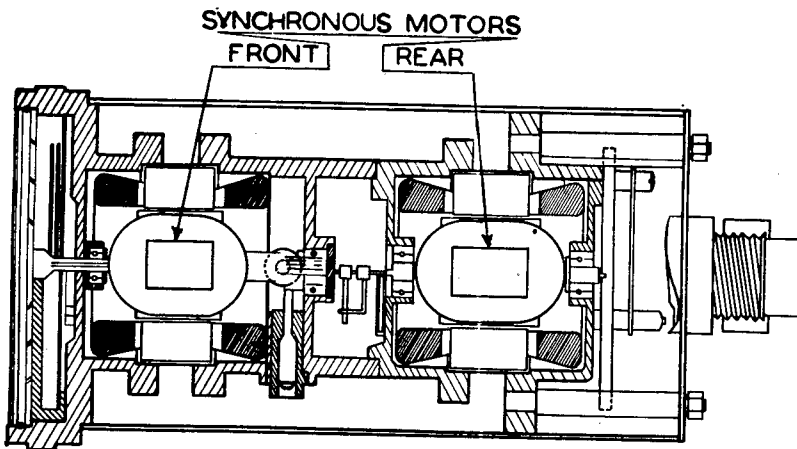
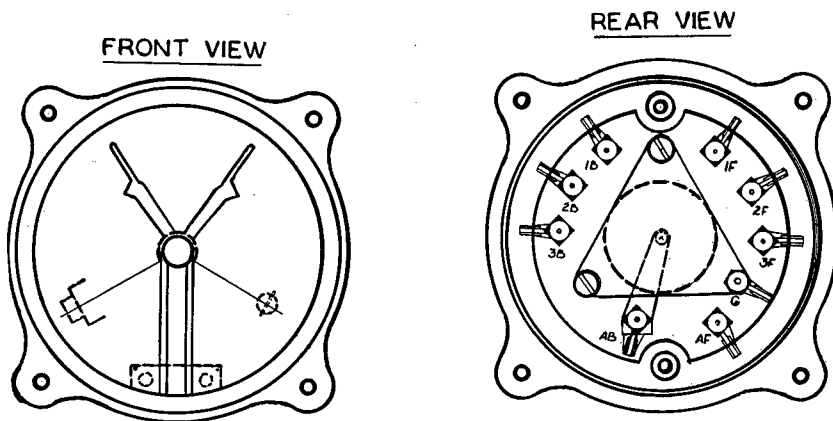

FIGURE 41.—Dual pointer, self-synchronous indicator.

case and is held by a small coil spring in contact with a silver slip ring on the rotor shaft.

c. The transmitter (fig. 42) consists of a motor similar to that of the single pointer indicator coupled directly to a mechanism having a diaphragm, Bourdon tube, centrifugal flyweights, or other

actuating element, depending on its function. The electrical elements of both the transmitter and indicator are similar except for the cases in which they are mounted. As with the indicator, the stator windings of the transmitter are connected to the terminals marked "1",

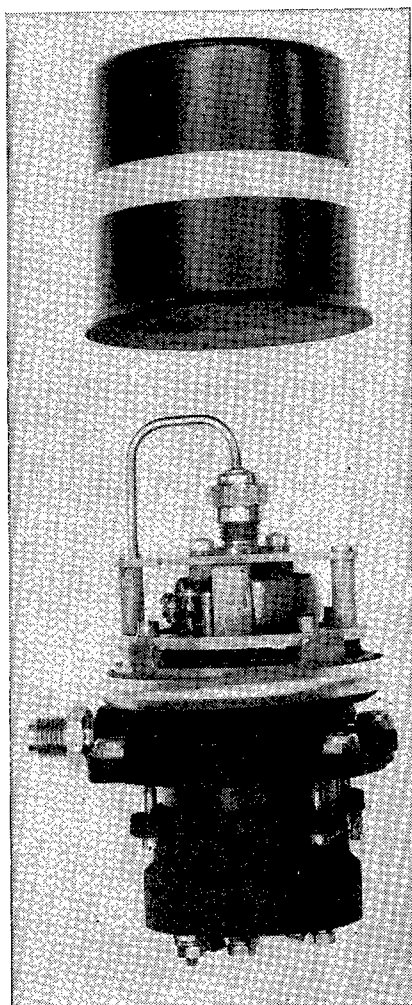

FIGURE 42.—Self-synchronous fuel pressure transmitter.

"2", and "3" and the rotor winding to the terminals "A" and "G" on the rear of the motor case. The motor of the transmitter may be said to occupy the place of the pointer on a conventional gage mechanism. The diaphragm, Bourdon tube or flyweights, as the case may be, causes the mechanism to rotate and assume a certain position to indicate a given pressure, rpm, or other condition. Thus, instead

of rotating a pointer as on a conventional instrument, the transmitter motor is rotated.

88. Operation.—*a.* The alternating current supply for the operation of the self-synchronous instruments is generally furnished by an engine-driven alternator or an electrically driven dynamotor. The current supply control switches are located at a convenient point in the cockpit. When the current is applied, all indicator pointers move from zero to a position on the scale that corresponds with the pressure or position element in the transmitter. Operation of the mechanical element in the transmitter is the same as for any conventional type of instrument of like kind described in other sections.

b. A wiring diagram of the self-synchronous instrument with indicator and transmitter is shown in figure 43. The three windings of the stators of both indicator and transmitter are respectively connected in parallel. Likewise the field windings of the rotors of both units are connected in parallel across the 32-volt a-c supply. When this a-c supply is turned on, the current in the rotors of both units will set up identical magnetic fields at right angles to the flow of the current in the windings as shown by the arrows in the wiring diagram. Since the rotor of the transmitter is fixed in a definite position by the mechanism of that unit, definite induced voltages will be set up in each of the three stator windings of the transmitter proportional to the number of lines of the magnetic field cutting each winding. For any given position of the rotor these three voltage values are fixed and correspond only to that position. Since the three stator windings of both the indicator and transmitter are connected in parallel, these same induced voltages will be present across the respective stator windings of the indicator and hence the indicator rotor, which is free to revolve, will assume the identical position of the transmitter rotor. No further movement of the indicator rotor takes place until the voltage values in the stator windings are changed by a movement of the transmitter rotor. In this way the indicator, which would otherwise be shown by a pointer mounted on the conventional gage mechanism, is transferred from the transmitter mounted at the place of measurement to the indicator mounted on the instrument panel.

89. Installation.—*a.* Typical installations of the self-synchronous system on a four-engine airplane are given in figure 44, showing the indicators, transmitters, and connecting leads. In figure 44 (1), the single pointer indicators are used, one set being employed for each engine. In figure 44 (2), the dual pointer indicators are used, requiring only one set for the right engines and one for the left. In addition, the use of selector switches allows four of the six engine functions in each case to be measured on one indicator.

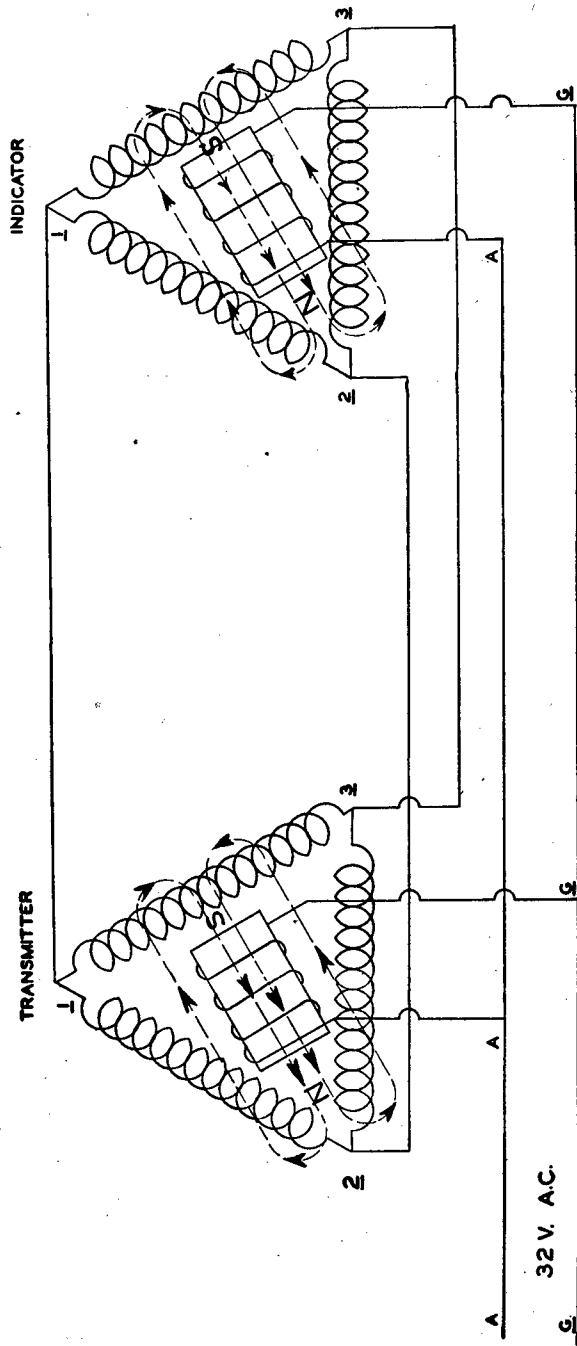
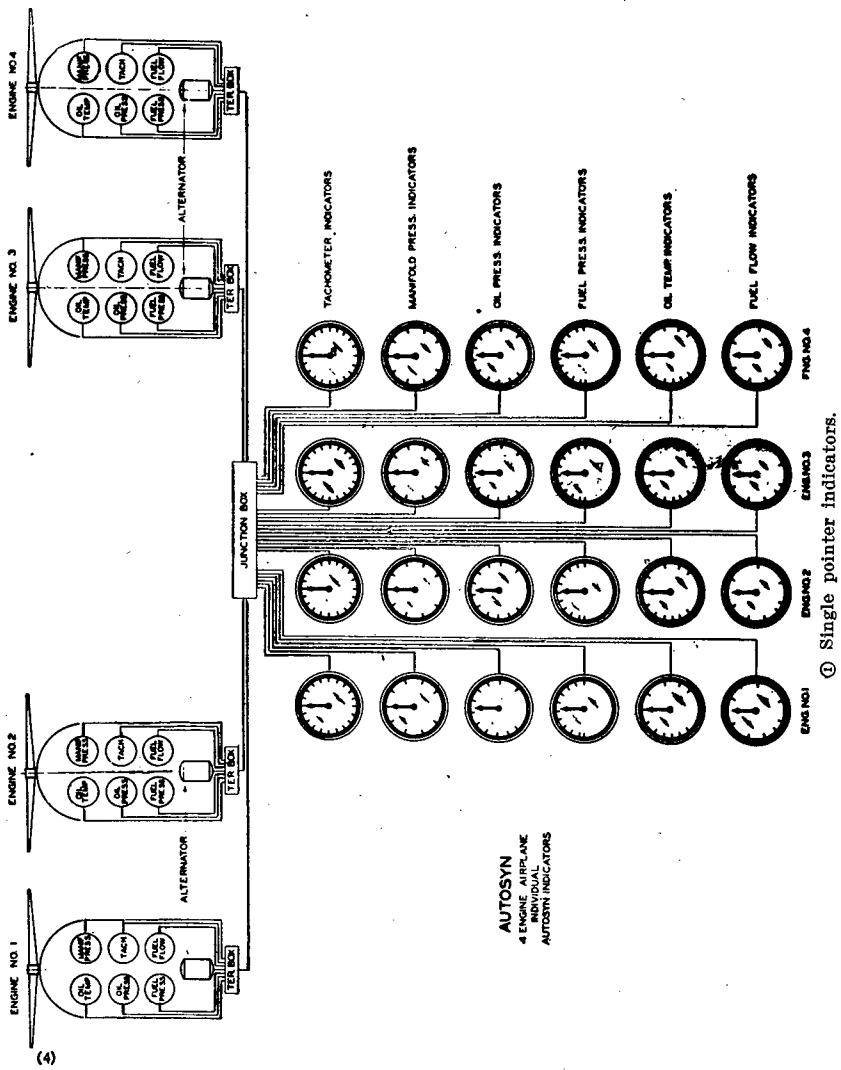

FIGURE 43.—Self-synchronous operation diagram.

b. General information on installation of instruments is given in section III. The indicators are mounted on shockproof instrument panel in the conventional manner. Transmitters are mounted on a vibration absorbing mount as near to the source of indication to be



transmitted as possible, usually in the engine nacelle. Installing replacements requires particular attention in insuring proper wire continuity, including the proper cleaning and the secure fastening of

all connections. For details on any particular installation reference is made to Air Corps Technical Orders for the particular airplane involved.

90. Maintenance.—See section II.

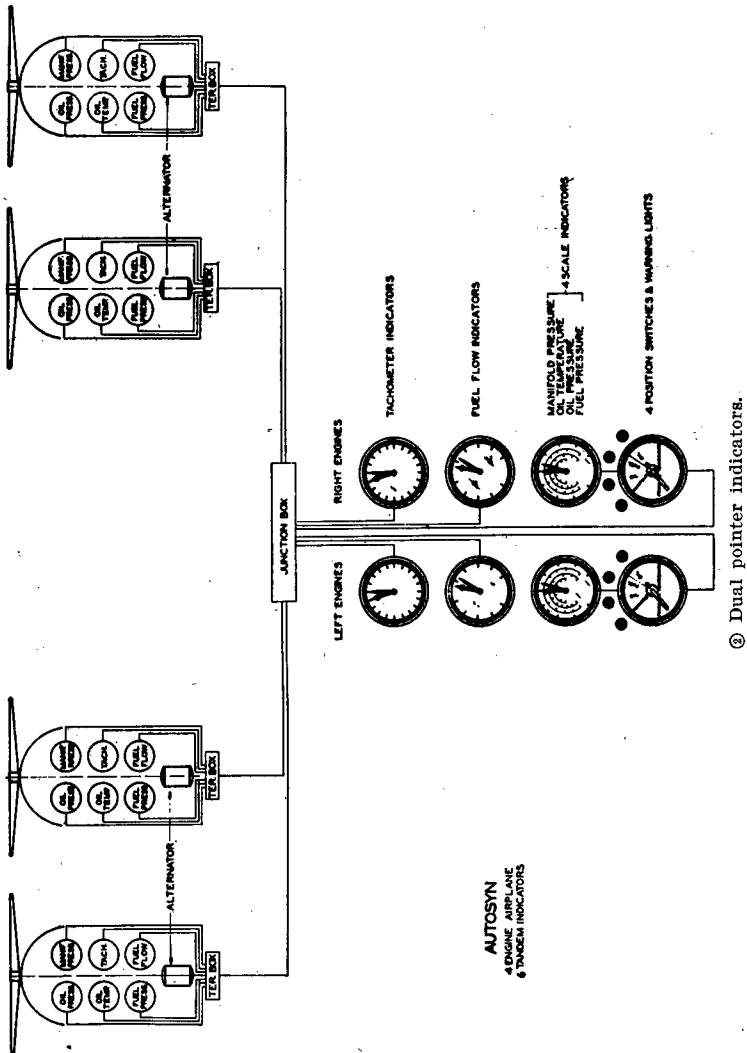

© Dual pointer indicators.

FIGURE 44.—Installation diagram of self-synchronous instruments.

SECTION XX

SELSYN INSTRUMENTS

	Paragraph
Purpose and use.....	91
Description.....	92
Operation.....	93
Installation.....	94
Maintenance.....	95

91. Purpose and use.—Selsyn instruments are used as position indicators to show the position of wing flaps and landing wheels.

92. Description.—*a.* The Selsyn instruments (fig. 45) consist of the indicator and the transmitter. The system is designed to operate

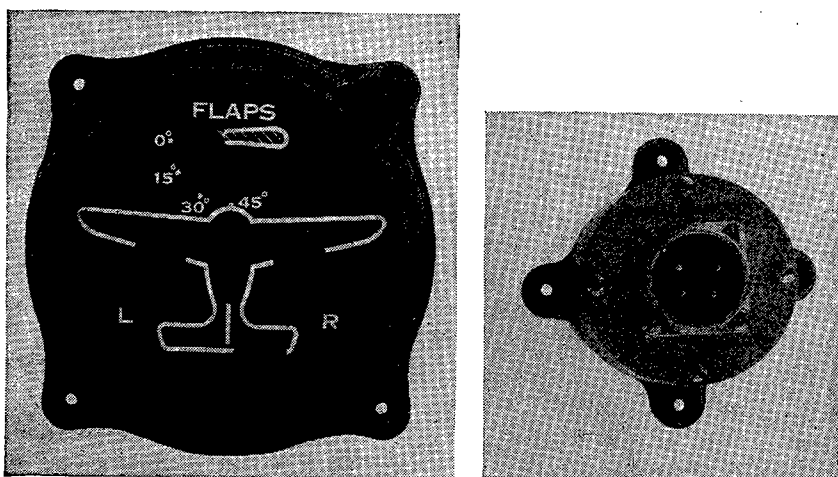

① Indicator.

② Transmitter.

FIGURE 45.—Selsyn position indicator and transmitter.

on direct current obtained from the standard battery generator systems.

b. The indicator is placed in a standard 2¾-inch shielded instrument mounting case which is provided with a 3-volt lamp for illumination, the receptacle being molded integral with the instrument case. It contains four indicating elements, one for the indication of the flap position and one for each of the three landing wheels. The connection to the elements is brought out to the back of the case through a 12-prong connector. Each element consists of a laminated ring of ferromagnetic material on which three windings are equally spaced in a delta connection. A polarized armature is supported in the center of this ring by two bearings and is free to rotate. It is surrounded by a

copper damping ring to prevent excessive oscillations. An aluminum disk, carrying the figure of a wing flap or wheel, is fastened to each of the four armature shafts so that the figure is visible through an opening in the indicator dial. On the dial there is an outline impression of a small airplane. The disks make or break the lines which form the outline so that the pilot is provided at all times with the picture of the actual position of the flaps and landing wheels. The disk at the top of the dial shows the position of the flaps and a scale graduated from 0° to 45° shows the degree of flap position. The two center disks marked "left" and "right" show the position of each of the main landing wheels. If the disks are at the top of the arced opening in the dial, the outline on the miniature airplane is complete and this indicates that the wheels are fully retracted. When the wheels are down in landing position, the disks are at the bottom of the arced opening and the outline of the miniature airplane will be broken. In the same manner the disk located at the bottom of the dial shows the position of the tail wheel.

c. The transmitter unit is housed in an aluminum housing and consists of a resistance wound on a circular form having an arc of 240° . Two spring contacts, attached to the shaft and secured together at an angle of approximately 120° , operate on this resistance. Through these contacts the current supply for energizing the units is transmitted from the battery generator system. The transmitter shaft is connected by an adjustable linkage to the wheels or flaps.

93. Operation.—A switch control is located in the cockpit for operating the Selsyn indicators. As shown in figure 46, the three equally spaced taps on the transmitter resistance winding are connected to the windings in the indicator in a series parallel circuit. For one given position of the contact arms, the current in each of the windings of the indicator will have a definite magnitude and direction. These currents each set up their independent magnetic fields to form a resultant magnetic field which has a definite magnitude and direction. The polarized armature of the indicator aligns itself with this magnetic field. The pointer dial is thereby controlled by the angular position of the transmitter shaft which in turn is controlled by the position of the wheels or flaps. Instruments designed for 12-volt systems will operate accurately on a voltage of not less than 10 or more than 15 volts.

94. Installation.—*a.* The Selsyn position indicator is located on and attached to the airplane instrument panel in a conventional manner.

b. The four transmitters are mounted on suitable brackets and located on the airplane so that wheel or wing flaps can be linked to a

bell crank and the bell crank fastened to the transmitter shaft. The link and bell crank should be adjusted so that the transmitter shaft will rotate approximately 60° for the change from the extreme up-and-down position of the wing flaps or wheels.

c. Connections from the power source through the transmitter to the indicator are made as in figure 47. Common conduit connectors are used for connecting the indicator to the transmitter and a standard connector plug is used to connect the lamp circuit. Indicators and transmitters are not interchangeable and the indications are not affected by the length of the leads. Correct polarity is of the utmost importance. The direction of indication will be reversed if the polarity of the transmitter contacts are reversed, if two of the leads between the transmitter and indicator are interchanged, or if the direction of rotation of the transmitter shaft is reversed. The wiring diagram should be followed closely to avoid this possibility.

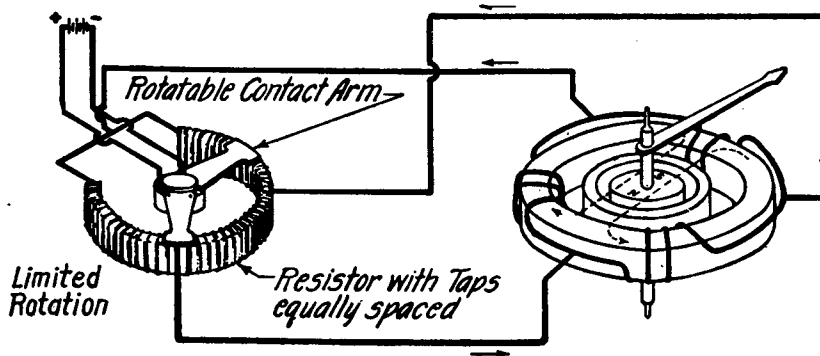

FIGURE 46.—Operation diagram of Selsyn transmitter and indicator.

95. Maintenance.—The general points on maintenance of instruments given in section II are applicable to this instrument. If in checking the continuity of the battery circuit it is found open or intermittent, the probable cause is an accumulation of dirt under one or both of the spring contacts of the rheostat in the transmitter. The contacts are cleaned by first removing the transmitter from the bracket and then removing the two nuts and felt gasket from the shaft and the four screws which hold the end plate to the case. The rheostat can then be carefully removed as a unit attached to the end plate by connecting wires and the contacts can be cleaned with a fine abrasive paper and the windings with a small brush. In assembling the rheostat to the case, care must be taken to have the dowel pin in the case enter the dowel hole in the rheostat to locate the rheostat and prevent it from turning. Care must be taken that neither the leads nor the windings are damaged, and

that the lead to the contact arm does not meet with interference as the rheostat is turned.

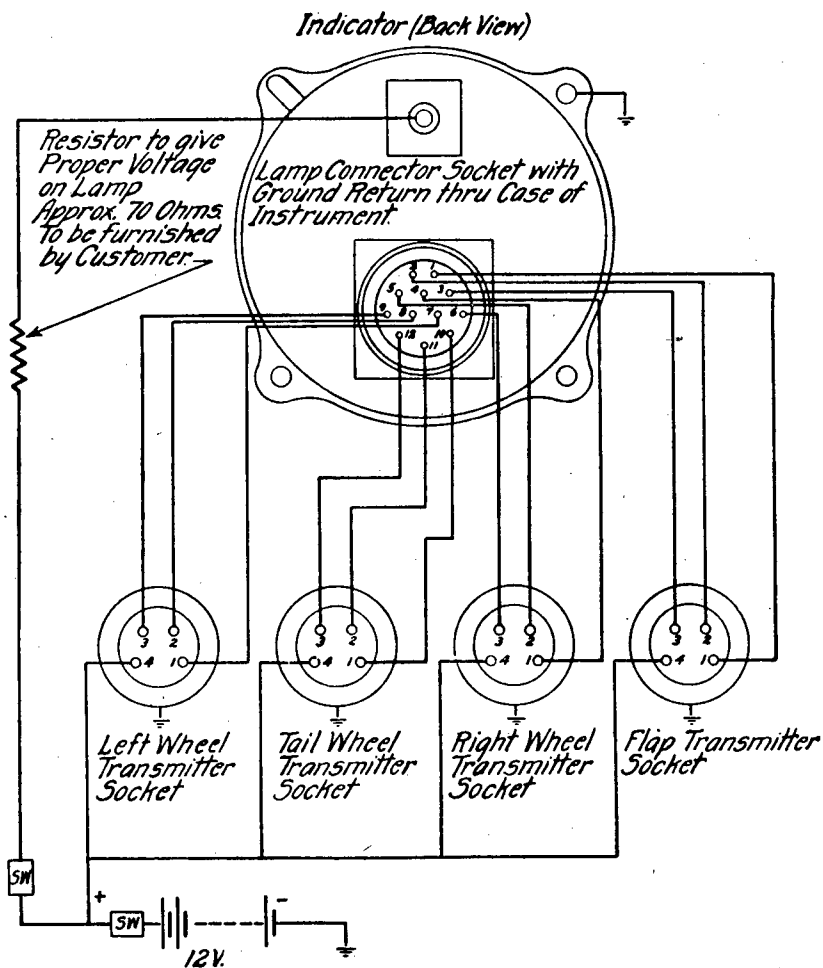

FIGURE 47.—Installation diagram of Selsyn wheel and flap position indicator.

SECTION XXI

FUEL LEVEL GAGES

	Paragraph
Purpose and use.....	96
Description.....	97
Operation.....	98
Installation.....	99
Maintenance.....	100

96. Purpose and use.—The purpose of these instruments is to indicate constantly to the pilot the amount of fuel in the fuel tank or tanks. This information enables him to judge the permissible distance of flight before it is necessary to refill the tanks or move the fuel cocks to the auxiliary or reserve tanks, and to determine the fuel consumption of an engine for a given time interval at certain speeds and throttle settings.

97. Description.—a. There is a large number of different types of these instruments which have various principles of operation. The

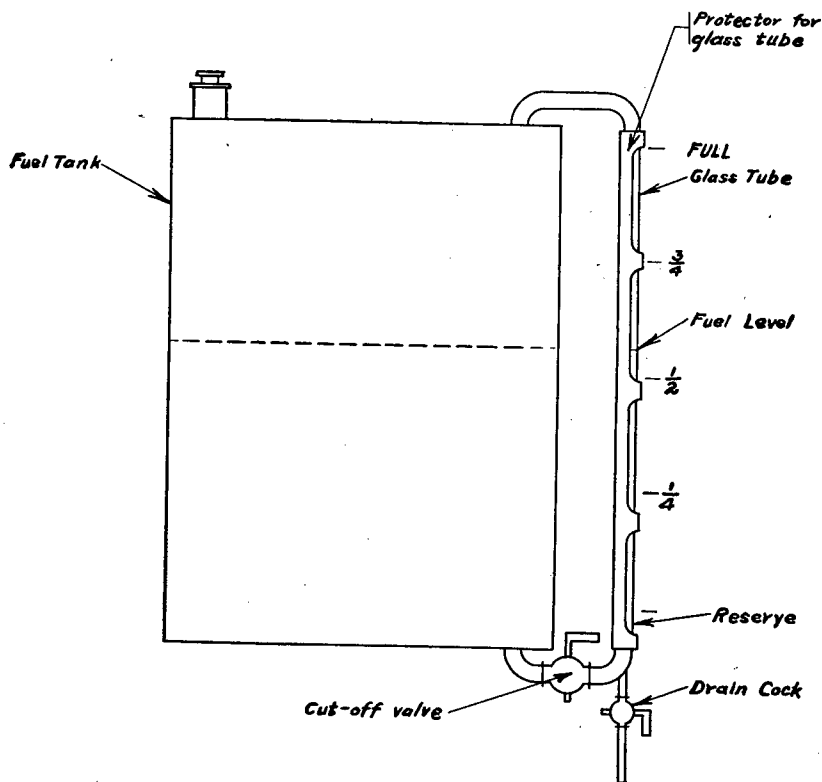

FIGURE 48.—Sight glass fuel level gage.

use of any given type generally depends on the type and size of the airplane on which the instrument is to be used, the particular manufacturer of the airplane, and the number and location of the fuel tanks. The instruments are usually composed of a float arrangement in the fuel tank, an indicator in the cockpit, and a means of transmitting the fuel level from the point of measurement to the point of indication. In general, the various types may be classified by the means used to accom-

plish this transmission, that is, liquid pressure, mechanical, and electrical.

b. The simplest form of fuel level gage is a graduated sight glass mounted directly on the fuel tank. A diagram of this installation is shown in figure 48 with the drain cock and the cut-off valve. Another form of the fuel level type, the hydraulically operated "liquidometer," is shown in figure 49. The instrument consists of a closed

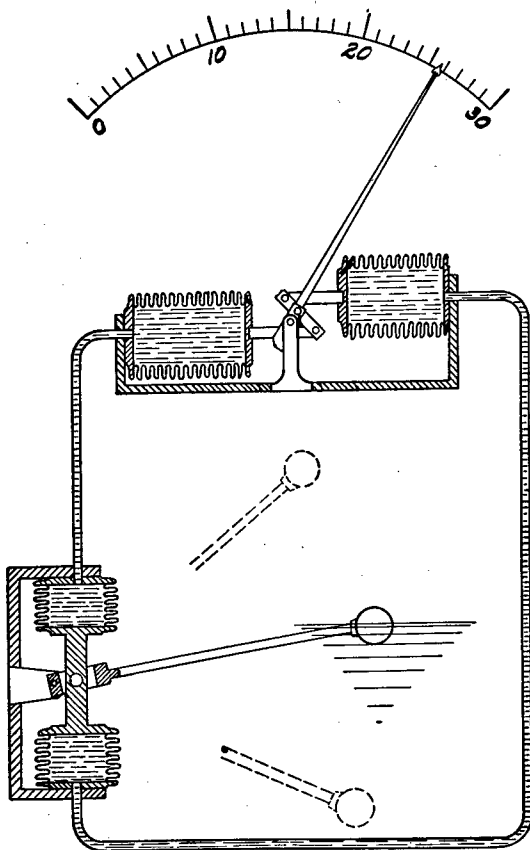

FIGURE 49.—Diagram of operating mechanism of hydraulically operated liquidometer.

hydraulic system, including an indicator unit, a tank unit, and the connecting flexible tubing. The indicator unit is made up of two multiple-ribbed bellows connected by a linkage to which is attached the dial pointer. The tank unit consists of a similar set of bellows connected by a fixed arm to which is attached the tank float. The movements of the float in either direction are transmitted to the set of bellows in the tank unit, causing a corresponding displacement of

the fluid in the connecting tubing which in turn operates the set of bellows in the indicator unit to control the position of the pointer. Any increase in pressure due to temperature expansion of the liquid in the closed system does not affect the position of the pointer since an equal force is created on both sides of the linkage. Thus the bellows are free to expand and contract without disturbing the position of the pointer, as it is supported by a bearing which is only affected when both bellows move in the same direction as a result of the float movement.

c. Three forms of fuel level gages in the second group are now in general use, the universal gage, the float and lever gage, and the direct reading float gage. The universal gasoline gage (fig. 50) is

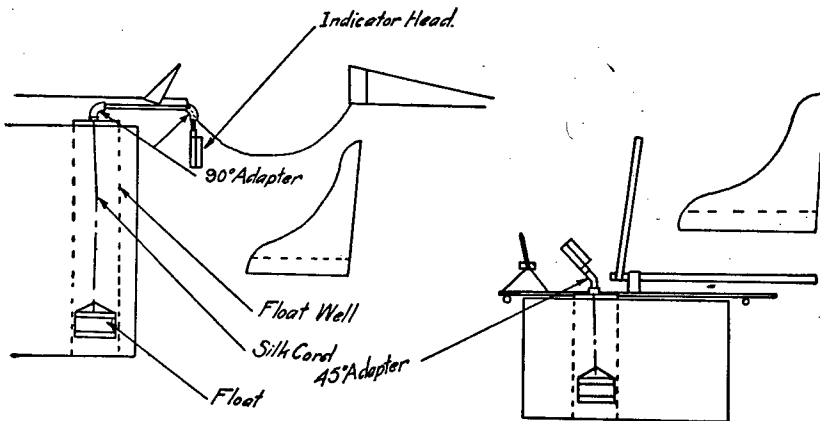

FIGURE 50.—Diagram of the universal fuel level gage.

generally used in large tanks. It consists of a float moving in a well in a gasoline tank. The movement of the float is communicated by means of a cord to an indicator placed on top of the tank or at some other point having good visibility to the pilot. The float is installed in the vertical well built for it in the fuel tank. The gage is mounted either directly on top of the tank or at some other location easily visible to the pilot. In the latter cases the cord is carried inside brass tubing, connections being accomplished by use of angle adapters (which contain rollers) at the necessary bends. The whole system is sealed against pressure or gasoline leakage, the glass of the gage being sealed in its case with a cork gasket and all connection joints by lead gaskets and shellac. The scale on the dial as furnished by the manufacturer is marked only at the point "empty". Other divisions representing the full and intermediate points usually represent fractions of the total full and are located by filling the tank with fuel in the desired amounts and marking each point on the dial. The dial is reversible, and by drilling special holes in it to fit the dial screws, the instrument may be set at any angle. The pointer pinion can be

meshed with the transmission gearing in such a position that the pointer will indicate correctly and the glass cover prevents the pointer pinion from becoming unmeshed. The float and lever fuel level gage and the direct reading float fuel gage are shown in figures 51 and 52.

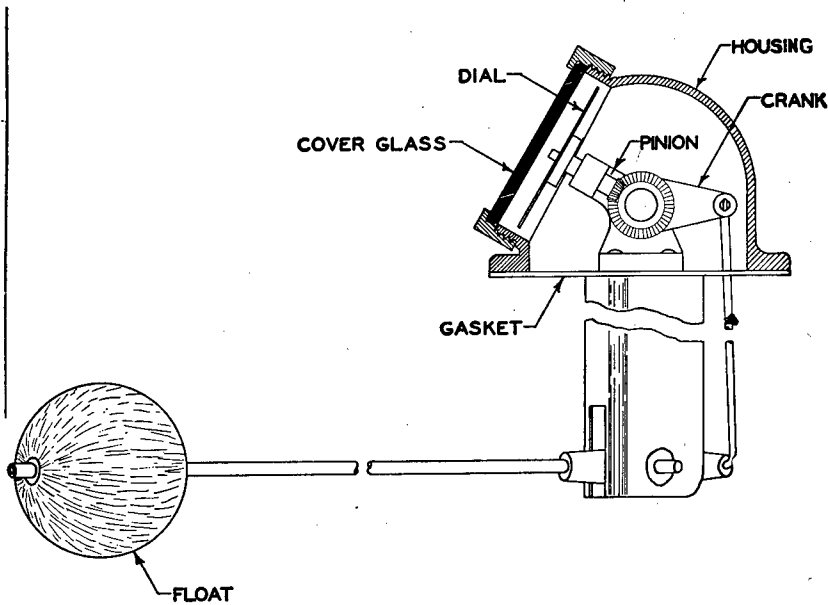

FIGURE 51.—Float and lever type fuel level gage.

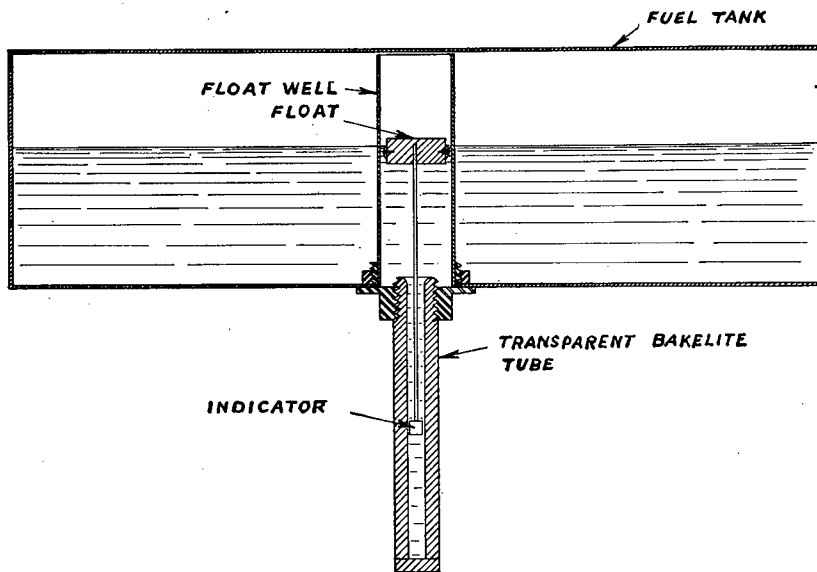

FIGURE 52.—Direct reading float type level gage.

Both depend on direct mechanical linkage for their operation. In the first the float movement is transferred through two lever arms and a worm gear to the pointer, while in the second the float is attached directly to the indicator by a fixed arm.

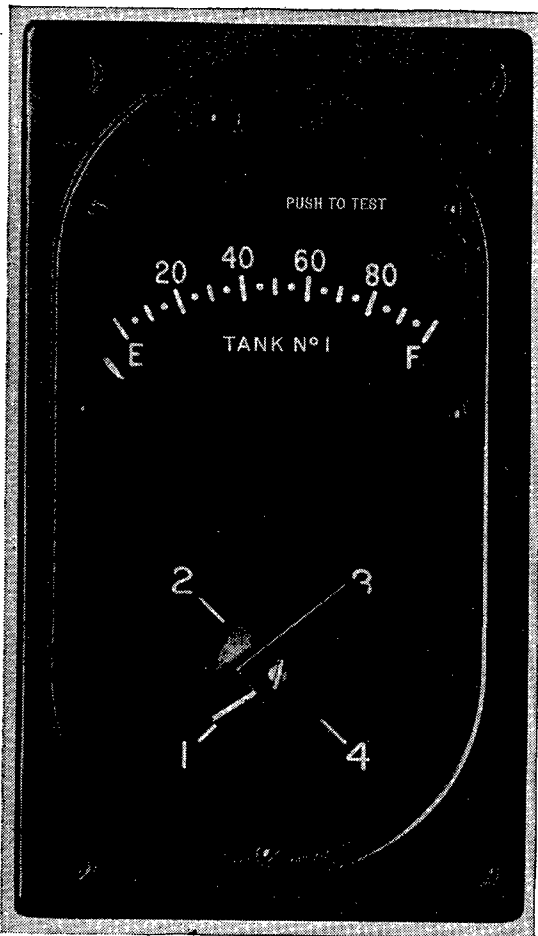

FIGURE 53.—Indicator unit of the ratio meter fuel level gage.

d. Of the numerous forms of electrically operated fuel level gages, several employ a D'Arsonval mechanism in the indicator. The various wiring circuits that are used in conjunction with these indicators and the specific details of any given installation may be found in pertinent technical publications or installations drawings. One of the later types of electrically operated instruments, the ratio meter, includes the dial change indicator and selector switch combination unit shown in figure 53 and the tank unit shown in figure 54. The indi-

cator unit has a revolving drum attached to which is a separate dial for each tank, a built-in selector switch, and a moving coil type ratio meter mechanism having two coils arranged to move in a nonlinear air gap of a permanent magnet. The coils carry the pointer and the control depends on the ratio of the currents in the coils. This indicator has a pointer travel of 70° and is arranged for indirect lighting. The tank unit consists of a circular housing to which is attached a supporting member on which a float arm pivots. Contained in this housing are a resistance strip (with provisions for adjusting stroke and end position) and a movable contact arm, this arm being connected by leverage to the float arm. A metal bellows mounted on the housing prevents fuel leakage.

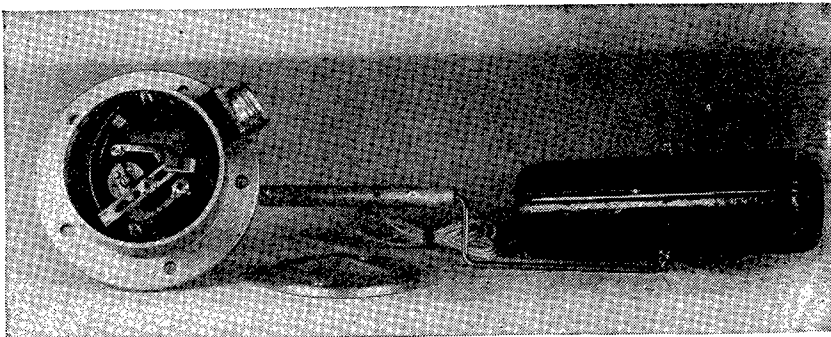

FIGURE 54.—Tank unit of the ratio meter fuel level gage.

98. Operation.—*a.* The operation of most types of fuel tank gages is quite simple and can be understood from the preceding description and inspection of the figures.

b. A wiring diagram of the ratio meter type with the “potentiometer unit” is shown in figure 55. A movable contact arm rotates on the variable resistance or “potentiometer unit” in the tank unit and controls the ratio of the current flowing through the two coils in the indicator. This in turn positions the coils in the nonuniform air gap and regulates the position of the pointer on the dial. A table is shown in the above figure giving the potentiometer resistance values for three conditions of pointer indication. When the selector switch knob is turned to a certain tank position, a dial calibrated for that tank automatically comes into view. The ratio meter indicator is not greatly affected by small changes in voltage and consequently a voltage compensation is not necessary.

99. Installation.—The fuel level gage installation varies for each type of instrument as well as each type of aircraft, therefore it is necessary to consult the Air Corps Technical Orders on the airplane

concerned for specific installation instructions. For general instructions, see section III.

100. Maintenance.—*a.* Direct reading sight glass types seldom require attention other than periodical draining to remove any sediment which may accumulate at the lower end. In case of breakage of the tube; the entire unit is removed and replaced with a new one. Periodic inspections should include a check of the tube throughout its length for cracks. The connections in which the tube is seated should be inspected for tightness, decomposed rubber fittings, loose

POINTER INDICATION	POTENTIOMETER UNIT RESISTANCE—OHMS	
	C TO +	C TO -
EMPTY	16.8	184.2
FULL	184.2	16.8
CENTRE	100.5	100.5

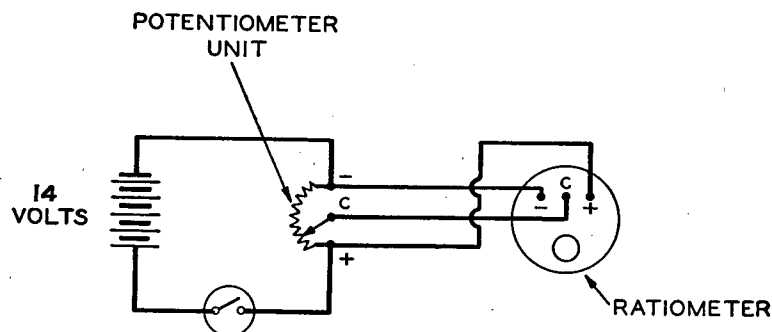

FIGURE 55.—Wiring diagram of the ratio meter fuel level gage.

clamps, or any other defect that might result in a leak. In the case of the "liquidometer" type, adjustment of the stroke of the float may be accomplished by means of two separate adjustments as shown in figure 56. The square block on the square shaft *B* controls the amount of pointer travel and the pointer position is controlled by the threaded adjustment *C*. Both these adjustments are so sensitive that only a small move is required in either direction. When the float is at the bottom of the tank, the adjustment screw *C* is moved until the pointer comes to the empty mark. The float is then moved slowly to the top of tank. If the pointer comes short of the full mark, the square block is moved in toward the transmission mechanism or outward if the pointer passes the full mark. Each time the square block is moved, it

AIRCRAFT INSTRUMENTS

will be necessary to reset the adjustment controlling the pointer position. The float should be moved slowly when making these adjustments. This should be repeated until the pointer moves from the empty to the full mark, when the float reaches the top and bottom of its swing. The jam nuts *D* are then locked, making sure that the screw *A* in the square block is tightened and the adjustment cover replaced.

b. Gages of the second group mechanical connection often fail to function from various causes, the principal ones being—

- (1) Sticking or bending of the float in the float well.
- (2) The float losing its buoyancy, which in the case of wood floats may be caused by the fuel soaking into the wood, and by leaks in the case of metal floats.

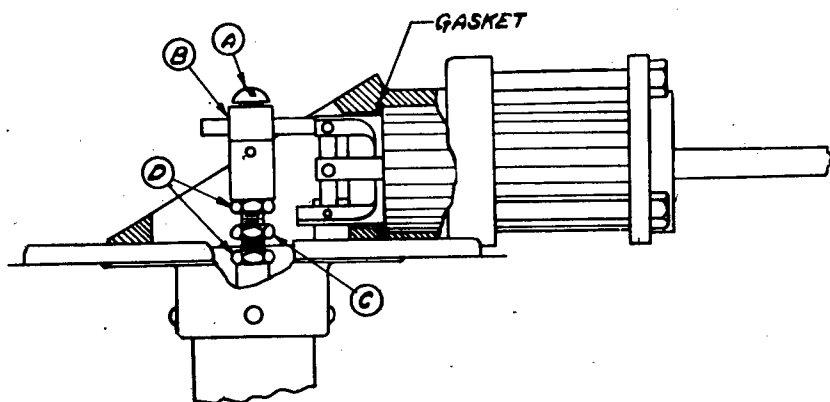

FIGURE 56.—Stroke adjustment mechanism of the hydraulically operated liquidometer.

(3) Sticking, binding, or breaking of the mechanism connecting the float to the gage. Any of these troubles would necessitate removal of the gage from the tank in order to remedy the malfunction. Extreme care should be exercised in case of removal not to damage the gaskets at the tank openings. The cords that connect the float with the indicator sometimes break in the case of the universal type of gage. To remedy this, the indicator is replaced with one on which the dial scale is graduated for that particular tank.

c. General information on maintenance of instruments given in section II apply to the electrically operated fuel level gages, and the specific maintenance instructions for any particular type may be found in the technical publications on that instrument.

SECTION XXII

AIRCRAFT COMPASSES (MAGNETIC)

Purpose and use.....	Paragraph 101
Description.....	102
Operation.....	103
Installation.....	104
Maintenance.....	105

101. Purpose and use.—*a.* In general, aircraft compasses are used for the following purposes:

- (1) To indicate the heading of the aircraft.
- (2) For locating the position of the aircraft by cross bearings.

b. The compass is a necessary navigational instrument for cross-country flying, patrol work, bombing expeditions, aerial photography, and flight through clouds. Its principal function is to indicate the direction in which the airplane is headed when flying on a straight course. However, it does not indicate correctly on turns made at velocities which require an appreciable banking of the airplane. The errors increase rapidly with the increase in the banking angle, a bank of about 20° being sufficient to destroy completely the function of the compass. This condition is inherent in any compass depending upon the earth's magnetic field for its directive effect and upon gravity for its stabilization.

102. Description.—*a.* The magnetic compass for use on aircraft consists essentially of a metal bowl filled with liquid and containing a card element carrying a system of magnetized needles so suspended on a pivot that it is free to aline itself with the meridian of the earth's magnetic field. The indications of the card and the reference marker or lubber's line are visible through a glass window of the bowl. An expansion chamber is built into the compass to provide for expansion and contraction of the liquid resulting from altitude and temperature changes. The liquid dampens the oscillations of the card. An individual lighting system is generally provided in the compass for illumination of the card when required for use during darkness.

b. Magnetic compasses for use on aircraft may be divided into two general types, type B for instrument board mounting to be used by the pilot, and type D for floor or table mounting to be used by the navigator.

(1) The type B compasses are available with cards graduated in either 1° or 5° increments. The models having the 1° graduations are intended for use on larger airplanes or when the 1° gradu-

ations are required by the pilot for navigation purposes. A front view of the type B compass having 5° increments is shown in figure 57①. The various models of this type are interchangeable insofar as mounting dimensions on the instrument panel are concerned but are not interchangeable as to dimensions back of the panel. The construction features of this type of compass are shown in figure 57②.

(2) The main characteristic of the type D (aperiodic) compass (fig. 58①) is the tendency of the card to return after displacement by one direct movement to its equilibrium position without executing a series of oscillations. This feature is obtained by the use of radial arms and damping vanes on the card which serve to increase the damping of the card movement in the liquid. These compasses are available with verge rings graduated in either 1° or 2° increments. Because of their different mounting dimensions, the two models are not interchangeable. Figure 58② shows the construction features of this type of compass.

103. Operation.—*a.* The earth acts as a huge magnet, with one pole near the north geographic pole and the other end near the south geographic pole. If a bar magnet is so suspended as to turn in any direction about its center of gravity, it will take a position with one end pointing toward the north magnetic pole and the other pointing toward the south magnetic pole. For this reason, the ends of magnets are known as the north-seeking or N-end and the south-seeking or S-end, respectively. Since the magnetic force acting on the N-end is equal and opposite to the force acting on the S-end, the effect on the N-end only is considered. The position taken by a freely suspended bar magnet gives the direction of the magnetic force or magnetic north. Thus the compass is a direction-indicating instrument. However, when installed in an airplane it is subject to additional forces.

b. There are four main causes for inaccuracy in aircraft compasses, incorrect installation, vibration, magnetism, and northerly turning error. Aircraft and instrument designers reduce or eliminate compass inaccuracies due to faulty installation and vibration by careful selection of compass location, use of vibration absorption mounts, provisions for level mounting, etc. During the construction of aircraft, the vibration and jarring of steel parts while being forged, machined, or fitted in place impart a certain amount of permanent magnetism which is induced by the earth's magnetic field. When the aircraft is placed in service, this permanent magnetism will vary due to vibrations of the engine, shocks from gunfire, landings, etc. This changing field of permanent magnetism correspondingly affects the action of the earth's magnetic field on the compass and thus causes

the compass card to deviate from the magnetic north. Further deviations of the compass result from electric currents flowing in the electrical system of the aircraft, radio equipment, electrical instruments, and from varying positions of metallic masses such as bomb loads, retractable landing gears, etc. If not excessive, corrections of compass errors resulting from the permanent magnetic influences referred to may be accomplished within close limits by the proper application of compensating magnets.

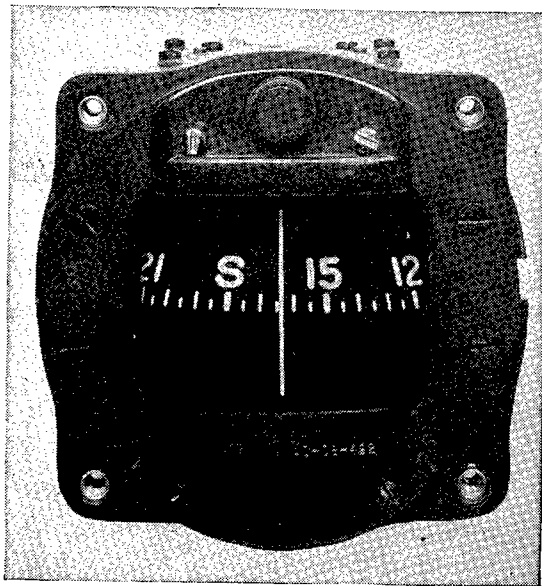

⊙ Front view.

FIGURE 57.—Type B pilot's compass.

c. The error of any compass is the angular difference between true north and compass north, or the angle between the true meridian and a vertical plane passing through the length of the compass needle. This angle is the algebraic sum of the variation and the deviation. Variation is caused by terrestrial magnetic influences and is the angular difference between true north and magnetic north measured from the true meridian. It is termed "west" when the terrestrial magnetism draws the compass needle to the left or west; and "east" when the needle is drawn to the right or east. Deviation is caused by the local magnetic influence of the aircraft in which the compass is mounted. It is the angular difference between magnetic north and compass north. As in variation, it is termed "west" when the influence acting upon the needle draws it to the left or west, and "east"

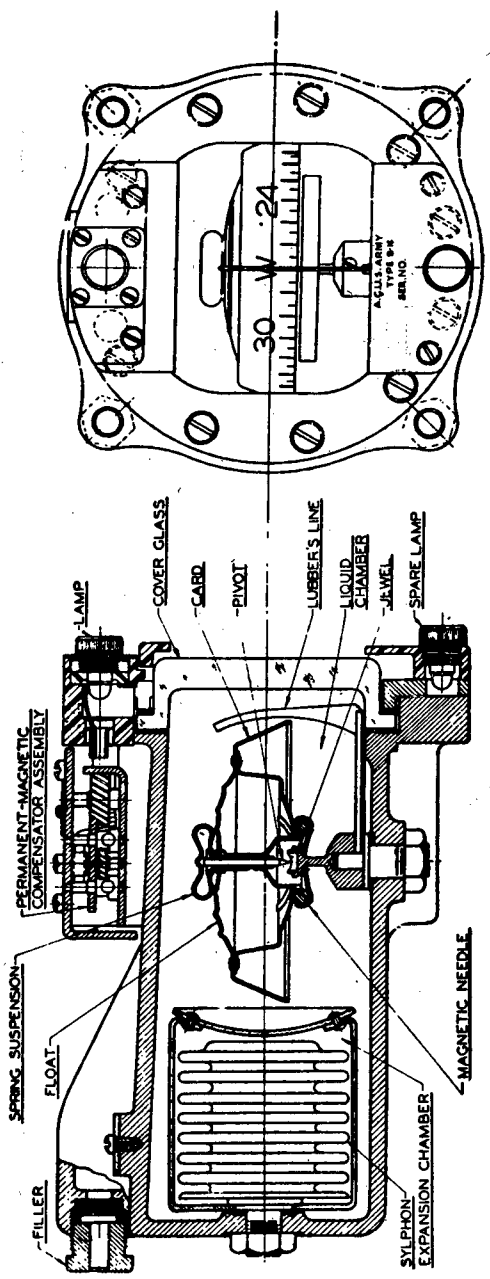

© Cross section.

FIGURE 57.—Type B pilot's compass—Continued.

when the needle is drawn to the right or east. Ordinarily the vertical component of the aircraft magnetic field has no effect on the compass readings, being at right angles to the compass card. However, when the aircraft is not in level flying position, this vertical component affects the compass card and produces a deviation known as "heeling" error. Correction for this error is not necessary as all compass readings, either when compensating or during flight, are made only with the aircraft in level flying position and engines running.

d. The type B compass for pilot's use indicates magnetic directions continuously and does not require a setting by the pilot to obtain the

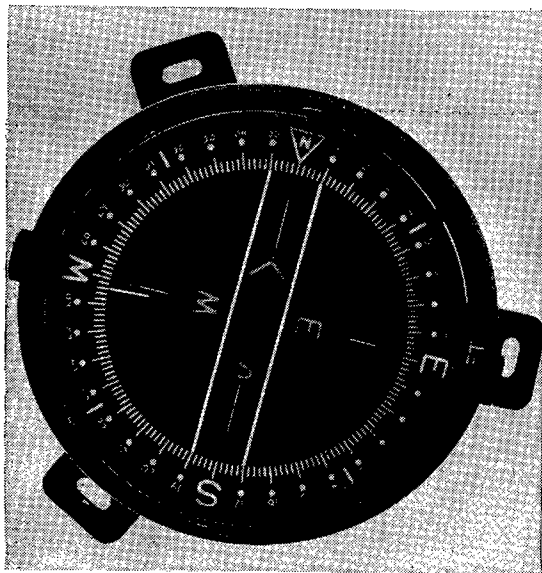

⊙ Top view.

FIGURE 58.—Type D navigator's compass.

heading of the airplane. The heading of the airplane may be read by viewing the indications on the compass card in reference to the lubber's line through a glass window in the front of the compass bowl.

e. The type D compass is for use by the navigator, and although this compass indicates magnetic directions continuously, it requires setting of the reference lines to obtain the heading of the airplane. This type compass is provided with a verge ring, which may be rotated to bring the grid wires or the lubber's line into alinement with the card pointer, after which the heading of the airplane may be read directly by means of the graduated scale on the verge ring. It is viewed through a glass window located in the top of the compass bowl.

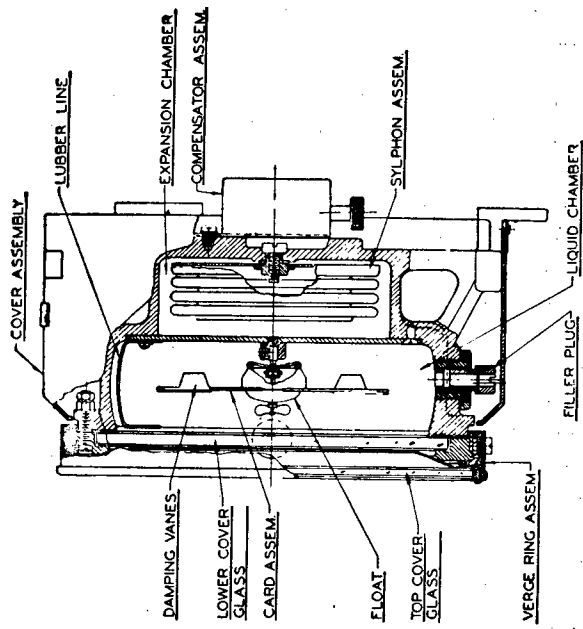

© Cross section.

FIGURE 58.—Type D navigator's compass—Continued.

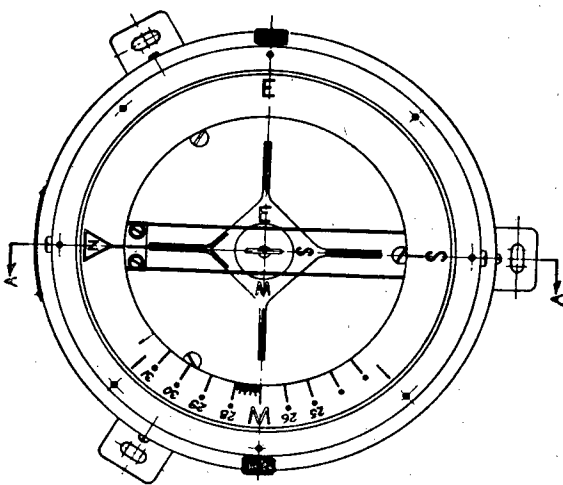

104. Installation.—*a.* Installation of compasses by service activities should always be made in the location provided in the airplane unless relocation is found necessary and is authorized. Compasses are installed by depots and airplane manufacturers so that a vertical plane passing through the card pivot and lubber's line will be parallel to the longitudinal axis of the airplane, and the card pivot supporting post substantially perpendicular to the horizontal plane when the airplane is in flying position. The type B compass is so constructed that these two conditions are fulfilled when the instrument board upon which it is mounted is perpendicular to the longitudinal axis of the airplane. The type D compass is so constructed that these two conditions are fulfilled when the surface of the base upon which the compass is mounted is parallel with the airplane leveling studs and a vertical plane through the card pivot and lubber's line of the compass is parallel to the longitudinal axis of the airplane. This can be accomplished by using a plumb line to establish the fore and aft axis or by marking a reference center line on the floor by measurements across the fuselage. The compass compensating chamber and adjusting screws must be easily accessible. The brackets required for mounting compasses are made of brass, duralumin, or other nonmagnetic materials and the mounting screws for compasses are of brass.

b. Special attention is given to the prevention of disturbing magnetic fields in the vicinity of the compass, either of a permanent nature such as may result from the proximity of electrical equipment, radio, armament, or structural members, or particularly of a varying nature such as may result from variations in current flow in electrical wiring or the position of retractable landing gears or kindred equipment. While a reasonable amount of permanent magnetism in the vicinity of the compass can be compensated for, the effect of variable magnetic fields cannot. The maximum deviation of the compass before compensation resulting from the effects of permanent magnetic fields must not be more than 25° for type B compasses, and not more than 15° for type D compasses. Deviations of the former after compensation must not exceed 10° and for the latter not more than 5° .

105. Maintenance.—*a.* The general points on maintenance given in section II are applicable to compasses. The normal service or line maintenance consists of the replacement of defective lamps, tightening of screws to eliminate leakage of liquid, checking lighting system for defective electrical connections, compensation, and replacement of defective compasses.

b. Compasses are removed and replaced by serviceable instruments if any of the following conditions exist:

- (1) Clouded or discolored liquid which impairs visibility.
- (2) Card markings are illegible due to discoloration, fading, or loss of luminous paint.
- (3) Card does not rotate freely in a horizontal plane when airplane is in normal flying position. This may be checked by deflecting the card with a small permanent magnet.
- (4) Bowl is cracked or mounting frame or lugs broken.
- (5) Compass is not responsive or is erratic in action after proper efforts to compensate.
- (6) Lubber's line is loose or misaligned.
- (7) Compass requires bench test, disassembly operations, additional liquid, or has any other major defects which might render it inoperative.

c. All compasses installed on aircraft, except primary training airplanes when used solely for airdrome flying, will be compensated and the readings recorded at each engine change period, at each change of guns or electrical equipment likely to affect the compass, or at least once during each 3-month period. However, if at any time the compass is suspected of being in error, it should be checked and compensated. The process of compensating for errors in compasses after installation in aircraft, that is, correcting within close limits the errors caused by magnetic influences and obtaining and recording the final deviations at the various points on the compass, is termed "swinging the compass." The compensation of compasses installed in aircraft cannot be expected to remain accurate for very long periods of time as it is known that under service conditions the magnetism of the aircraft structure is constantly changing both in intensity and direction. The following instructions should be observed during the compensation of all magnetic aircraft compasses:

- (1) See that the airplane is at least 100 yards from any steel structure, underground cables, or metal drainage pipes, concrete containing steel reinforcements, or other aircraft.
- (2) Insofar as possible place all controls, guns, etc., containing ferrous material in flying position, except when engines are running the elevators should be used to assist in keeping the tail of the airplane down.
- (3) If the compass employs loose magnet compensators remove all magnets from the chambers prior to compensation and keep all unused magnets away from the compass at least 2 feet.
- (4) Cause the compass card to deflect through a small angle using a small permanent magnet for this purpose (compensating magnet).

Note whether the card rotates freely on its pivot and its path of rotation is in a horizontal plane. Read the compass only from a position directly in front of (pilot's type) or above (navigator's type) the lubber's line to avoid erroneous readings.

(5) To swing an airplane on the magnetic bearing swinging base, first place the airplane in level flying position on the base with the longitudinal axis parallel with the magnetic meridian; that is, parallel to the N-S line as shown in figure 59. Then if the compass does

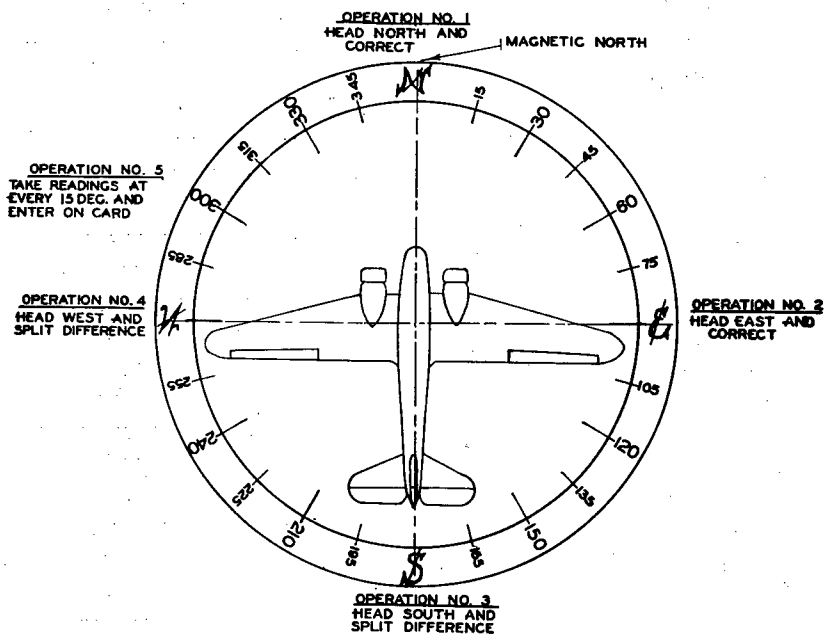

FIGURE 59.—Diagram showing procedure used when swinging aircraft compasses.

not indicate north (0°), insert sufficient compensating magnets in the athwartship chamber if compensator is of the loose magnet type, or adjust the compensating screw marked N-S if it is of the permanent magnet type, until the compass indicates north (0°). Then with the engine or engines running and speeded up sufficiently so that the maximum charge is shown on the ammeter, note whether the compass still indicates north (0°). If the compass heading is affected by the electrical current flow, it will be necessary to make further magnet corrections in order that the compass will indicate north (0°) under flight conditions. The airplane should then be headed east (90°) and the above process repeated, bearing in mind that in this position compensating magnets should be inserted in the

fore and aft chamber, or the compensating screw marked E-W adjusted to obtain the desired compass heading of east (90°).

(6) If during the compensation of the compass on the north and east headings there is no apparent change noted in the indications of the compass as a result of running the engines, there will be no further occasion to keep them running during the remaining period of compensation. However, with the engines stopped, the compass should be tapped lightly by hand before each reading is taken to eliminate errors due to friction.

(7) The airplane should next be headed south (180°) and if the compass does not indicate south, change the compensating magnets in the athwartship chamber or adjust the N-S compensating screw to eliminate one-half the error. By so doing, the error is divided between the north and south headings. The airplane should then be headed west (270°) and if the compass does not indicate west, change the compensating magnets in the fore and aft chamber or adjust the E-W compensating screw to eliminate one-half the error on this heading, thus dividing the error between the east and west headings. This procedure results in a more even distribution of the compass errors at all points.

(8) The actual compensation of the compass is now completed. The airplane should next be swung on each successive 15° heading, starting at any convenient point, and the compass readings recorded in the "radio off" space provided on the compass correction card. Then, with the radio receiver in the "on" position, the airplane should again be swung on each successive 15° heading and the compass readings recorded in the "radio on" space provided on the compass correction card. The engines will be operated as specified in (6) above if the N and E headings were affected when compensating.

(9) All entries on the compass correction card must be the actual indicated readings on all headings. After all entries have been properly made and the card dated and signed, it is placed in the holder provided for ready reference during flight.

(10) To swing an airplane by using a master compass, the same procedure as outlined in (5) above is followed, except that instead of the magnetic bearing swinging base, any serviceable magnetic compass may be used as a master compass, provided the compensating magnets have been removed before being so used. A compass having compensating magnets installed, either of the loose type or permanent type, cannot be used as a master compass. When swinging an airplane with a master compass, the compass should be attached to the wing as near the tip as possible by using a compass swinging

frame. These swinging frames have been supplied to service activities.

d. With the advent of aircraft of such size as to be unwieldy on the ground, the problem of swinging such airplanes by ground methods is extremely difficult. An increased amount of electrical and radio equipment and the incorporation of retractable landing gears and similar equipment are reasons for a more vigilant attitude with respect to compass errors, since the increased range of present-day aircraft demands a more precise method of navigation. It is definitely known that the compass errors on the larger aircraft as determined by ground swinging methods and air swinging methods are far from identical, although every reasonable precaution is taken on the ground to duplicate air conditions. Further information on both ground and air swinging of aircraft compasses may be found in Air Corps Technical Orders.

SECTION XXIII

AIR SPEED INDICATORS

	Paragraph
Purpose and use.....	106
Description.....	107
Operation.....	108
Installation.....	109
Maintenance.....	110

106. Purpose and use.—*a.* The air speed indicator shows the rate of speed that the airplane is traveling through the air. Except in still air at normal sea level atmospheric pressure, the indicated air speed is different from ground speed. However, the pilot may calculate ground speed from the indicated air speed if he knows the altitude at which he is flying and the direction and speed of the wind.

b. Some specific uses of the air speed indicator are to aid in—

(1) Estimating the actual ground speed of the airplane. This is necessary in cross-country flying when the time required to reach a landing field must be determined, in bomb sighting, and gunnery exercise.

(2) Determining the best throttle setting for the most efficient flying speed.

(3) Determining the best climbing and gliding angles.

(4) Determining whether the speed attained in a dive is within the limits of safety for the structure of the airplane.

(5) Indicating to the pilot when the airplane has attained flying speed in the take-off, and when the stalling speed is being approached in landing.

c. The reliability of an air speed indicator is dependent upon the pressures delivered by a pitot static air speed tube and the response of the mechanism of the air speed indicator to these pressures. Because of greater reliability, as compared to pitot venturi tubes, electrically heated pitot static air speed tubes have been made the standard for the

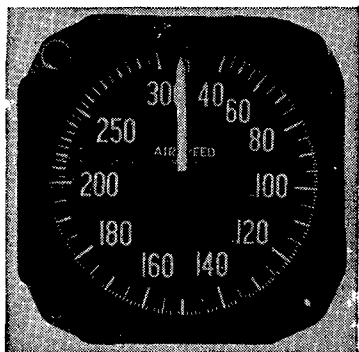

⊙ Front view.

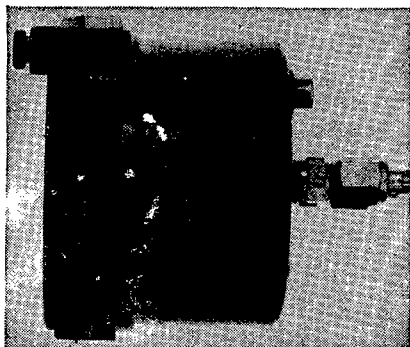

⊙ Side view.

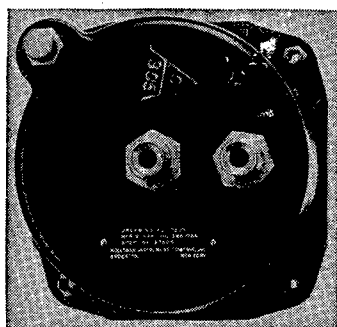

⊙ Rear view.

FIGURE 60.—Low range type of air speed indicator.

Air Corps. The pitot static air speed tubes are practically free from errors resulting from slight deposits of dust, oil, or water and electrical heating will prevent ice formation on the tube under the most severe icing conditions.

107. Description.—*a.* The two types of air speed indicators in general use are shown in figures 60 and 61. The internal mechanism and operating principle of all air speed indicators are the same, the only difference being in minor construction features and in the range of the instrument. The low range type indicates air speeds of 40 to

300 mph and the high range type indicates air speeds of 50 to 500 mph.

b. The indicator (fig. 62), consists primarily of an airtight diaphragm assembly *D* and a mechanism for multiplying its deflection. The mechanism is composed of a rocking shaft assembly *R* with diaphragm lever *A*₁ and a long lever *A*₂, a sector assembly *S* with a sec-

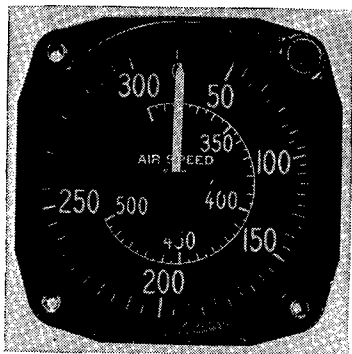

FIGURE 61.—High range type of air speed indicator.

tor lever *A*₃, and a hand staff *G*, and pinion *P*. A hairspring *C*, secured to the hand staff and anchored to the mechanism body, removes backlash from the mechanism and holds the diaphragm lever against the diaphragm bridge. The entire mechanism is housed in an airtight case. The pitot tube which is connected to the interior of the diaphragm and the static tube which is connected to the case are treated in detail as separate instruments in section XXIV.

c. In external appearance, the different air speed indicators are similar, except for the appearance of the dials and small variations in the length of the case. The cover glasses are held in the case by means of a snap ring. The back of each instrument contains a centrally located pitot pressure connection and an offset static pressure connection. Each of these connections is made up of an internal pipe thread insert in the case and a nipple union.

108. Operation.—*a.* The mechanism of the air speed indicator responds to small differential pressure changes. The phosphor-bronze or beryllium-copper diaphragm capsule is sufficiently sensitive to move under very slight changes of pressure. Since the impact pressure from the pitot tube is transmitted to the interior of the diaphragm capsule and the static pressure from the static tube is transmitted to the interior of the otherwise airtight indicator case and the outside of the diaphragm capsule, it thus responds to the difference between the pitot and static pressures. As the speed of the airplane increases, the pitot pressure inside the diaphragm causes the latter to expand. The rocking shaft picks up the motion by means of its diaphragm

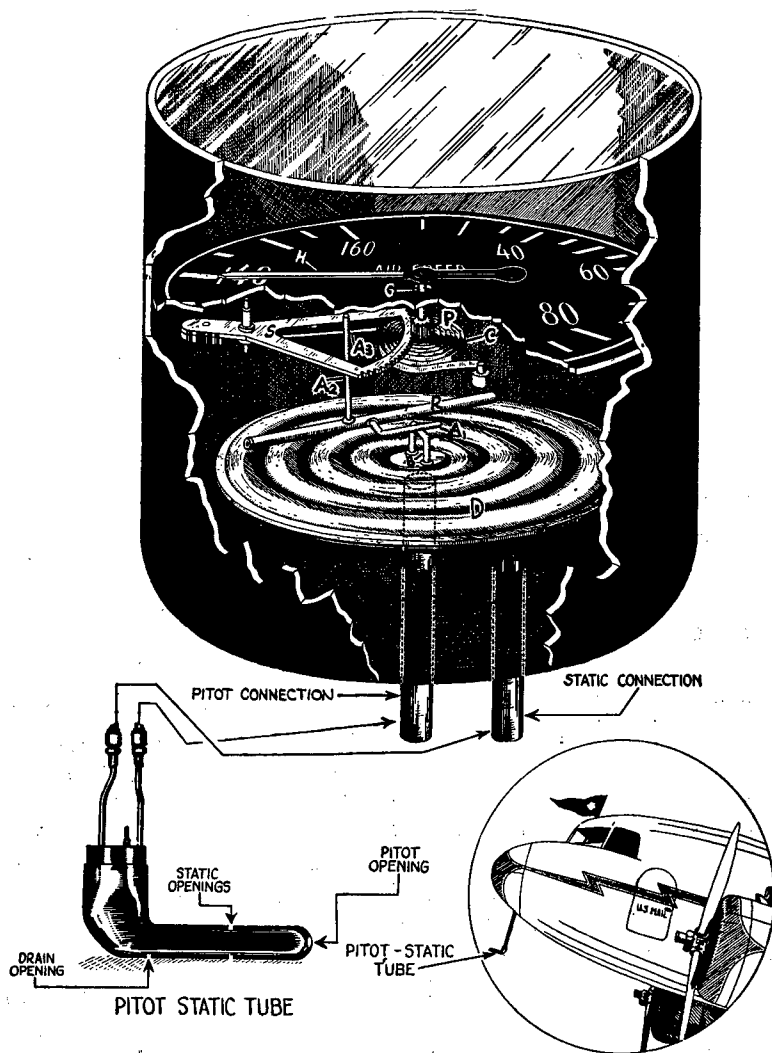

FIGURE 62.—Diagram showing air speed indicator mechanism and connection to pitot static tubes.

lever and in turn transmits this motion through the long lever to the sector and finally to the handstaff pinion. The pointer fastened to the handstaff indicates air speed in miles per hour.

b. The fact that air speed indicators may be in error due to installation and instrument maladjustment must be realized, and these errors must be taken into account when extremely accurate use of the indicator is required. Therefore, to determine true indicated air speed the corrections given below are to be determined and applied.

(1) Since the pitot static tube is seldom installed in an air stream free from disturbances caused by the aircraft structure, the differential pressure developed by the tube differs from the theoretical value. The error in the indication of speed due to this difference in differential pressure is called the "installation error."

(2) Indicators may also be in error due to the imperfect calibration to the standard air speed pressure relation or to the effect of temperature changes in the instrument. For a change in instrument temperature from +45° C. (113° F.) to -35° C. (-31° F.), the errors should not exceed 3½ miles per hour at any point on the scale. There are various types of Air Corps standard computers which may be used to facilitate the correction of air speed indications.

109. Installation.—*a.* The air speed indicator is grouped with the other flight instruments. It is mounted so that the zero on the dial is on the top side. Installation is made in accordance with various airplane and instrument board drawings. Mounting screws as required are furnished with each instrument.

b. The *P* (pitot) and *S* (static) connections on the back of the instrument case are connected to the corresponding connections on the air speed tube by means of airtight lines of seamless copper or aluminum tubing. When seamless copper tubing is used, the fittings will be either three-piece solderless or cone unions and when seamless aluminum alloy tubing is used, the fittings should be aluminum alloy 17ST, anodically treated, solderless fittings. The connecting lines are carried inside the fuselage and wing structure to prevent damage. The altimeter and rate of climb indicator are also connected into the static line. Each pitot and static pressure line should incorporate a flexible connection located behind the instrument board in such a manner as to complete the insulation of the instrument board from the vibrations of the airplane structure.

c. The lighting system of each of the air speed indicators is designed for a 3-volt source. The electrical connector socket in the back of the case is connected to a 3-volt supply by means of a standard electrical connector plug in accordance with airplane installation drawings or specific Air Corps Technical Orders affecting the various types of airplanes.

d. In the calibration of air speed indicator installations on various types of airplanes, it has been found in some cases that the maximum permissible diving speeds exceed the scale range of the instrument. Whenever this condition exists, the air speed indicator is replaced with one having the necessary higher scale range.

110. Maintenance.—The general points on service inspection and maintenance of instruments given in section II are applicable to air

speed indicators. The specific points of inspection and the procedure for dependent operating units are given in section XXIV.

SECTION XXIV

AIR SPEED TUBES

	Paragraph
Purpose and use.....	111
Description.....	112
Operation.....	113
Installation.....	114
Maintenance.....	115

111. Purpose and use.—Air speed tubes are used on aircraft to furnish accurate values of impact (pitot) and static pressures caused by the motion of the aircraft through the surrounding air. Specifically, they are used to supply—

- a. Impact pressure to the sensitive element of the air speed indicator.
- b. Static pressure to the cases of air speed indicators, altimeters, and rate of climb indicators.

112. Description.—a. The air speed tubes, of which there are two general types, are located in such a position that in flight they will be in undisturbed air. One type of tube (fig. 63①) is designed for installation on a tapered streamline mast extending below and forward of the nose of the fuselage. Another type of tube (fig. 63②) is designed for installation on a boom extending forward of the leading edge of the wing. This boom is tapered in such a way that a minimum of vibration will result under flight conditions. Although the construction of the two types differs slightly, their component parts and principle of operation are the same.

b. The air speed tube (fig. 64) is a two-section tube made of heavy gage brass seamless tubing. It is located on the airplane so that its axis is parallel with the longitudinal axis or thrust line of the aircraft out of the slip stream and free from disturbances caused by the aircraft structure. The forward section is open to the front in order that it may be subjected to the full force of the impact pressure. This impact pressure section is provided with a baffle plate to prevent blowback of moisture and dirt into the tube and a small drain hole at the bottom to dispose of moisture and condensate. Another drain hole is located in the shark fin part of the impact pressure section. While the leaks caused by these drain openings are so small that their effect on actual measurement of the impact pressure is negligible, they must be closed or sealed with masking tape when

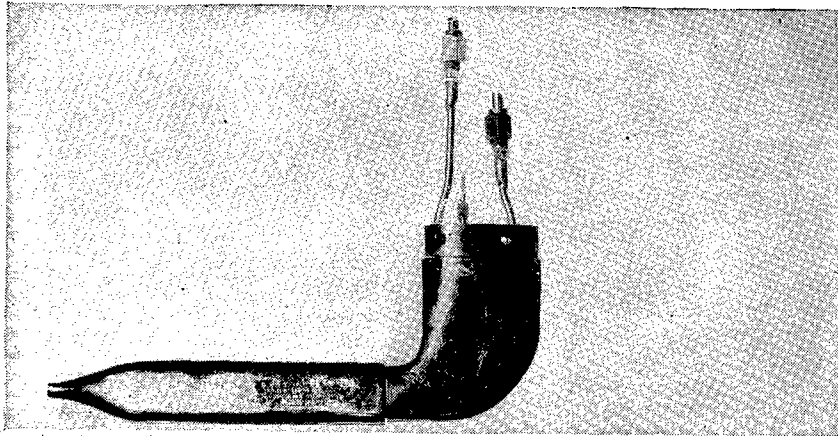

① Mounted under nose of fuselage.

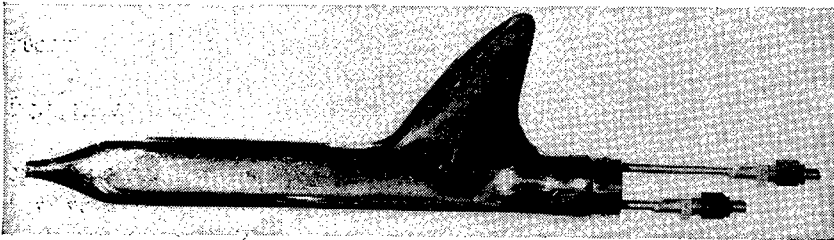

② Mounted forward of leading edge of wing.

FIGURE 63.—Streamline type air speed tubes.

the periodic leak test is made on the pitot pressure system. The rear of the static section of the tube is provided with three small openings on both the top and bottom surfaces which, because of their design and location, give accurate measurement of air in static condition and also provide a means of draining this section.

c. Risers are provided in the shark fin projection at the rear end of the tube to which are connected the tube extensions leading to the instruments. This type of construction reduces to a minimum the possibility of fouling the system with ice and dirt. The air speed tube is provided with two heating elements as shown in figure 64 to prevent icing when such condition is prevalent during flight. These elements are of excellent construction and will not burn out easily. Most of them will give trouble-free service for the life of the tube.

d. As described in section XXIII, the impact (pitot) pressure is transmitted by airtight tubing connections to the pitot pressure connection of the air speed indicator and the static pressure is trans-

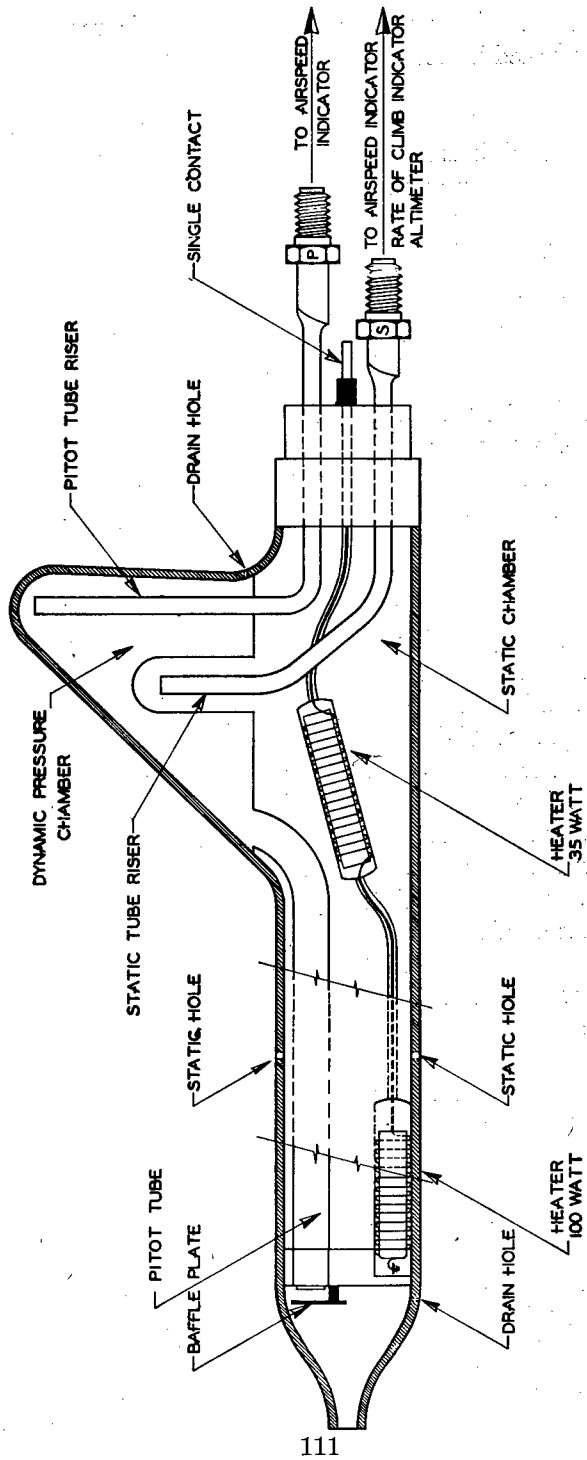

FIGURE 64.—Cross section diagram of an air speed tube.

mitted by airtight tubing connections to the static pressure connections of the air speed indicator, altimeter, and rate of climb indicator.

113. Operation.—Ordinarily the air speed tube requires no attention from the pilot. Pitot and static pressures are transmitted to the altimeter, air speed indicator, and rate of climb indicator instantaneously and without manual control. However, under ice-forming conditions in flight, the pilot should turn "on" the switch labeled "AIR SPEED TUBE." When icing conditions are no longer encountered, the switch should be turned "off." The electrical circuit of the heating element of the tube is connected through the ignition switch for all engines in such a manner that when the ignition switch is "off," the electrical circuit of the tube is open, and when the ignition switch is "on" the electrical circuit of the tube will be controlled by the "on-off" switch labeled "AIR SPEED TUBE." Precautions must be taken by placing the switch in the "off" position while on the ground or when heat is not required so that discharging the battery will be prevented and the life of the heating elements in the tubes will be lengthened.

114. Installation.—In order to permit removal and replacement of the air speed tube, a union is placed in each connecting line at the point of attachment of the mounting boom or mast to the wing or fuselage. The union is accessible through an inspection door. In removing a tube first disconnect these unions, then remove the mounting screws and lockwashers. The tube may then be pulled out of its mount a few inches and the pitot and static tubing and the "snap-on" electrical connector disconnected. To replace the tube, the above procedure is reversed. For detailed installation instructions consult Air Corps Technical Orders on mounting and wiring for individual types of airplanes.

115. Maintenance.—*a.* Particular care should be exercised in keeping the air speed tube clean at all times. When airplanes are not flying, the air speed tube should be protected from dust, dirt, oil, and other foreign particles by an appropriate cloth, canvas, or leather sack with a streamer. The sack should cover all openings in the tube.

b. The electrical circuit of each installation is tested to determine whether the heating element of the tube is connected satisfactorily. With the heating element of the tube properly connected and operating from the combined generator and battery source of direct current at 14.25 volts, the voltage as measured at the tube will not be less than 12.0 volts; with a battery source of 12 volts, the voltage as measured at the tube will not be less than 10.5 volts.

c. With the instruments properly connected to the static pressure line, the static pressure slotted openings or holes of the air speed tube

are suitably connected to a source of suction. The altimeter pointers are set to indicate zero. A suction is slowly applied in sufficient amount to cause the altimeter pointers to indicate 1,000 feet of altitude (approximately 1.05 inch Hg. or 14.24 inches water, suction) at which point the source of suction is "pinched off." During a period of 1 minute, the altimeter pointers should not change their position by more than 150 feet; that is, they should not indicate less than 850 feet of altitude. The altimeter or instrument board is tapped during the 1-minute period to remove the friction effect from the indication of the pointers. *Do not apply pressure to static lines.* Regulate the show application and removal of suction by means of the indication of the rate of climb indicator which should not exceed 2,000 fpm. Individual altimeters, rate of climb indicators, and air speed indicators should be tested for leaks in accordance with the Air Corps Technical Orders governing their use.

d. In testing the pitot lines, the pitot pressure chamber drain holes of the air speed tube are sealed. With the air speed indicator properly connected to the pitot pressure lines, the pitot pressure opening of the air speed tube is suitably connected to a source of pressure. A pressure is slowly applied in sufficient amount to cause the air speed indicator pointer to indicate 150 mph (approximately 0.82 inch Hg. or 11.18 inches water pressure) at which point the source of pressure is pinched off. During a period of 1 minute, the air speed pointer should not change its position by more than 10 mph (it should not indicate less than 140 mph). The air speed indicator or instrument board is tapped during the 1-minute period to remove the friction effect from the indication of the pointer. *Do not apply suction to pitot lines.*

SECTION XXV

ALTIMETERS

	Paragraph
Purpose and use.....	116
Description	117
Operation	118
Installation	119
Maintenance	120

116. Purpose and use.—a. Altimeters are used for two distinct purposes in aircraft:

(1) To measure the elevation of the aircraft above some point on the ground regardless of its elevation above sea level. This method

of altitude measurement is called the "field elevation pressure" system. The "field elevation pressure" is the existing atmospheric pressure at a point 10 feet above the mean elevation of the runway and is obtained by applying a suitable correction to the station pressure. It is assumed that the altimeter in an airplane is 10 feet higher than the landing surface.

(2) To measure the elevation of the aircraft above sea level. This method of altitude measurement is called the "altimeter setting" system. The "altimeter setting" is the atmospheric pressure in inches of mercury and is the existing station pressure reduced to sea level in accordance with the U. S. Standard Atmosphere (N. A. C. A. Report 538).

b. The specific uses of the field elevation pressure system are to—

(1) Determine accurately the vertical distance between the aircraft and objectives on the ground when performing tactical missions.

(2) Indicate the elevation of the airplane above the runway for coordination with other instrument indications when making instrument landings.

c. The specific uses of the altimeter setting system are to—

(1) Indicate at all times the elevation of the airplane above sea level so that it can be compared with strip maps for the purpose of clearing critical points and mountain peaks safely.

(2) Use advantageously the meteorological data supplied by weather stations such as wind velocities and directions for various elevations, and elevations of cloud and storm formations that are to be avoided in flight.

(3) Observe and correctly follow airways traffic regulations.

(4) Furnish information for changing the blade settings of controllable pitch propellers.

117. Description.—*a.* All altimeters used on military aircraft are of the sensitive type shown in figure 65①, utilizing an aneroid mechanism. This mechanism is very sensitive and well-balanced, jeweled bearings being used at all principal pivots to reduce friction. A temperature compensator is included in the mechanism and partially corrects for the mechanical error resulting from changes in temperature. Figure 66 shows a typical sensitive altimeter mechanism wherein *D* is the aneroid and *F* the temperature compensating unit which connects to the aneroid by T_1 and T_2 . The expansion of the aneroid *D* through linkage causes the rocker shaft *R* to turn. Sector *S*, which is part of rocker shaft *R*, engages a pinion and gear causing the movement of the indicating hands over the engraved dial.

b. Standard models of altimeters for tactical operation have a calibrated range of from 1,000 feet below sea level (-1,000 feet) to 35,000 feet above sea level (+35,000 feet). By use of a multiple

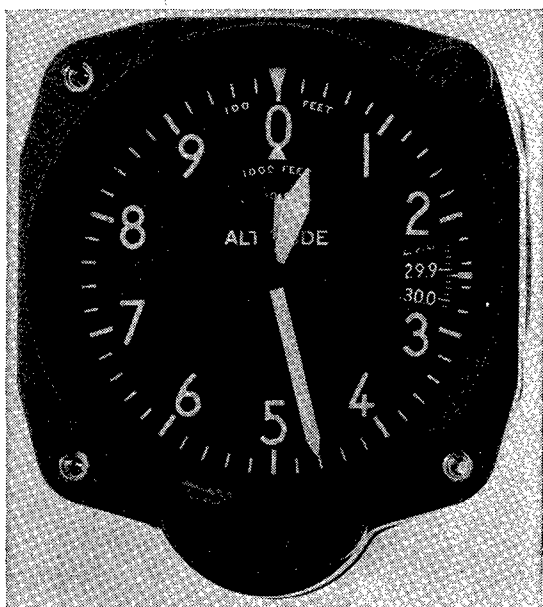

Ⓢ Sensitive altimeter.

SCALE CORRECTIONS

ALTIMETER No. 41-11301

Altimeter reads—	Add	
	Room temperature +25°C.	Low temperature -35°C.
0	+20	+40
500		
1000	+35	+50
1500		
2000	+35	+50
2500		
3000		
4000	+10	
6000	+10	+40
8000	+35	
10000	+50	

Altimeter reads—	Add	
	Room temperature +25°C.	Low temperature -35°C.
12000	+65	+70
14000	+70	
16000	+60	
18000	+50	+50
20000	+55	
22000	+75	
24000	+75	+60
28000	+65	
32000	+85	
35000	+150	+140

Date: 9-29-41

Tested by: John Doe Depot:

Ⓢ Altimeter scale correction card

FIGURE 65

pointer system, the instrument can be read accurately to at least one-half the smallest unit graduation on the scale. The later types of altimeters have one altitude scale, one barometric scale with an index marker, two reference markers, and three pointers as shown in figure 67. The altitude scale, having major divisions of 0 to 10, is fixed and the pointers, reference markers, and barometric scale rotate

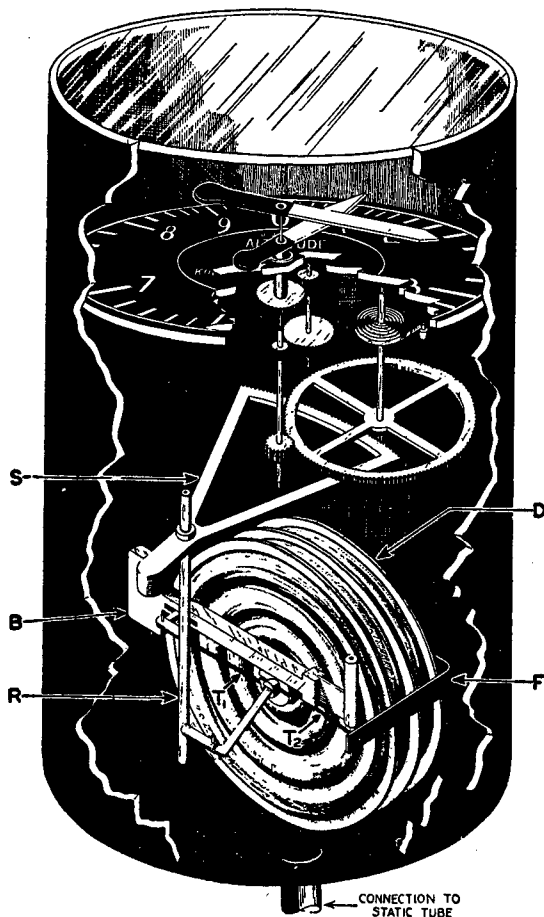

FIGURE 66.—Internal mechanism of the sensitive altimeter.

and indicate with reference to it. A setting knob located at the bottom front of the instrument case drives two pinions in opposite directions. One of these pinions rotates the barometric scale and reference markers and the other pinion rotates the aneroid mechanism assembly of which the pointers are a part. The three pointers or

indicating hands are concentrically arranged and indicate on the one common dial. The long pointer is referred to as the "minute hand," the intermediate pointer as the "hour hand," and the small pointer as the "second hand." The minute hand makes one revolution for a change of 1,000 feet, the hour hand makes one revolution for a change of 10,000 feet, and the second hand would indicate 100,000 feet for one revolution if it were not restrained. To cover the full range of the instrument, the minute hand makes a total of 36, the hour hand 3.6, and the second hand 0.36 revolutions. The position of the reference markers are read on the same dial as the pointers. The outer one which rotates on the periphery of the dial makes one revolution for 1,000 feet and the inner one makes one revolution for 10,000 feet. The standard range for the barometric scale is 28.1 to 31.0 inches Hg. with unit graduations of 0.02 inches of Hg. When the limit of the range of the barometric scale is reached at either extreme, a shutter blanks out the indication of the barometric dial and the barometric pressure is read from the position of the reference markers by computation. By introducing a limited range barometric scale, the actual unlimited possibilities of setting barometric pressure by means of the reference markers is not in any way affected.

c. The entire mechanism is enclosed in a two-piece bakelite case which is provided with a vent in the rear case wall for connection to the static line of the pitot static system. Since this instrument must be sealed airtight, its only opening is through the static vent. Due to the fact that the mechanism is mounted in a bakelite case which is a nonconductor of electricity, a suitable means is provided to bond electrically the mechanism to the airplane structure. This is accomplished by attaching a phosphor-bronze spring to the brass insert on the back of the case, which takes the nipple for the static connection and makes a sliding contact with the mechanism when it is rotated by the setting knob. The present standard sensitive altimeters are provided with a 3-volt ring light and reflector, the receptacle being molded integral with the instrument case. Later type sensitive altimeters eliminate the 3-volt ring light and instead are designed for fluorescent lighting.

118. Operation.—*a.* The altimeter being an absolute pressure-indicating instrument, its operation is obtained by the changes in the existing atmospheric pressure. This makes the instrument practically automatic in operation. The gear ratio of the hands being ten to one gives a multiple pointer system of extreme sensitivity together with the high ratio multiplying mechanism in the linkage system. When installed in an airplane, it is essential that the aneroid

be subjected to the same existing atmospheric pressure as that through which the airplane is flying and the air must be undisturbed (static). This is especially true on aircraft utilizing a sealed cabin wherein pressures are carried in excess of the altitude through which the craft is flying. This extreme change in pressure, if allowed to leak into the static line, is capable of causing the altimeter to indicate not the pressure through which the craft is flying, but rather the pressure within the craft. Consequently the altimeter must be vented to the static line and the entire installation must be free of all leaks.

b. Operation of the altimeter will depend upon the nature of the work and the mission that the airplane is to perform. There are two systems that are adaptable when using the sensitive altimeter and with each system there are two methods of setting off variation; that is, in feet of altitude with the reference markers or in inches Hg. on the barometric scale. The reference markers are used only on tactical missions such as bombing. Operation of either system is dependent upon radio contact with the ground stations which are equipped with either station altimeters or very accurate barometers.

119. Installation.—All general points on the installation of aircraft instruments that are applicable to altimeters are given in section III. The altimeter must be connected to the static line of the pitot static system. This will insure correct operation as long as the pitot static tube is correctly alined with the direction of flight, provided there are no leaks in the entire system.

120. Maintenance.—*a.* The general points on inspection and maintenance of instruments given in section II are applicable to altimeters.

b. The following specific points and procedures are applicable to standard altimeters:

(1) Just prior to take-off, the altimeter is set for use on either the field elevation pressure or altimeter setting system. For flight of a local nature or practice in instrument landings, the knob is turned so that the pointers indicate zero. On this setting, the reading indicated on the barometric scale will be the local barometric pressure in inches Hg. Where cross-country flights are anticipated, the knob is turned so that the pointers indicate the surveyed elevation of the field from which the take-off is to be made. On this setting, the reading indicated on the barometric scale will be the local pressure reduced to sea level altimeter setting.

(2) Check setting knob for free and easy turning, also see that all pointers, reference markers, and the barometric scale move when setting knob is turned.

(3) To check the zero setting error, obtain the reading from the station altimeter. Set pointers of the airplane altimeter to zero; vibrate panel two or three times while making this setting, then check reading of reference markers. Their reading should be the same as the pressure altitude on the station altimeter plus or minus 30 feet. If the error exceeds the permissible tolerance of plus 30 feet, loosen small screw located just to the left of setting knob. (This screw does not come out; excessive pulling will seriously damage the instrument case.) After the screw is loosened, push it and lock pin to which it is attached all the way to the left as far as it will go. Then pull out on setting knob and turn, so that the reference markers correspond with the pressure altitude obtained from station altimeter. Push knob in, reseal lock and screw. It is to be noted that when checking and setting the reference markers, the corrections on the scale correction cards of the airplane and station altimeters must be taken into consideration.

(4) To check the case for leaks, disconnect static connection at the instrument; place a short piece of rubber tubing over the vent marked "S"; with mouth pressure only, decrease the altitude indication by only 500 feet. Pinch off the tubing and watch the pointer for 10 seconds. The pointer position should not change more than 20 feet during this interval.

c. (1) The aneroid mechanism of an altimeter is also affected by expansion and contraction due to changes in temperature. Even though each instrument is compensated for temperature changes, an error remains which varies at different temperatures throughout the range of the instrument. These errors must be within the tolerances specified in the Technical Order for the particular instrument.

(2) Figure 65② shows a scale correction card which contains scale corrections for a particular altimeter. The card affords a visual means of determining the magnitude of the remaining errors due to instrument temperature change. The scale corrections are scale errors with the signs reversed, to be added to or subtracted from (as indicated by the sign) the reading of the altimeter. For example, if the altimeter reads 2,000 feet, a correction of +35 feet must be made for a temperature of +25° C., and accordingly, the corrected altitude is 2,035 feet. For instrument temperatures between the values of +25° C. and -35° C. (temperature limits shown on correction card), interpolation is necessary. For example, the scale correction at 2,000 feet is +35 feet at +25° C. and is +50 feet at -35° C.; therefore there is a variation in the scale correction at this altitude between

these two temperature of 50 minus 35, or 15 feet. Accordingly, an approximate correction of $\frac{15}{60}$ or $\frac{1}{4}$ foot is necessary for each degree change in temperature. If the temperature at 2,000 feet were 0° C., a correction of $\frac{1}{4} \times 25$, or approximately 6 feet, would be necessary in addition to the value of 35 feet, or a total of 41 feet; therefore the corrected altitude is 2,041 feet. This method is applied for any altitude and temperature within the ranges specified on the scale correction card.

(3) The scale correction card is placed in a holder as near as is practicable to the altimeter, to which it refers. When calibrating the altimeter in an airplane, the scale correction card should be consulted. When an altimeter is replaced, the scale correction card is removed from the holder and attached to the instrument.

(4) Only those scale errors determined by an accurate mercurial barometer at the time the altimeter is calibrated for acceptance or after repair are used in determining scale corrections for entry on the card.

(5) Should it become necessary to use the old type altimeter, complete information may be secured in section V, paragraph 3b, Technical Order 05-30-1.

AIRCRAFT INSTRUMENTS

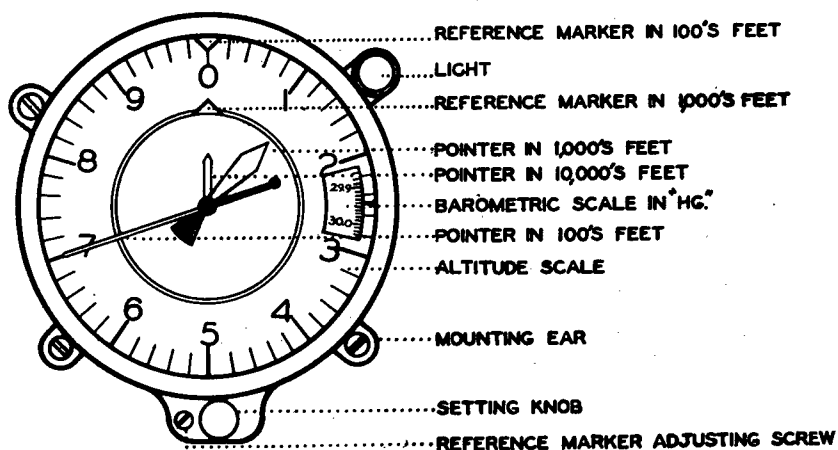

FIGURE 67.—Altimeter setting system.

SECTION XXVI

RATE OF CLIMB INDICATORS

	Paragraph
Purpose and use.....	121
Description.....	122
Operation.....	123
Installation.....	124
Maintenance.....	125

121. Purpose and use.—Rate of climb indicators, also called climb and dive indicators, are instruments designed to show gain or loss of altitude regardless of attitude of the aircraft. Specific uses for this instrument are to—

- a. Show rate of ascent.
- b. Show rate of descent.
- c. Accomplish banked turns without gain or loss of altitude.
- d. Establish constant and definite rates of descent when making an instrument landing.

122. Description.—*a.* Rate of climb indicators, which consist essentially of an indicator unit and a thermos chamber, are of several types. The older type (fig. 68) has the chamber as a separate unit and in the later type (fig. 69), it is built integral with the instrument case. These differences do not affect or change the principles involved or vary the method of operation.

b. Figure 70 shows the internal mechanism and parts of the indicator unit. The inside of the diaphragm *A* is subjected to the air pressure in the thermos chamber, connection being made by means of the diaphragm tube, case chamber connection *B*, and the con-

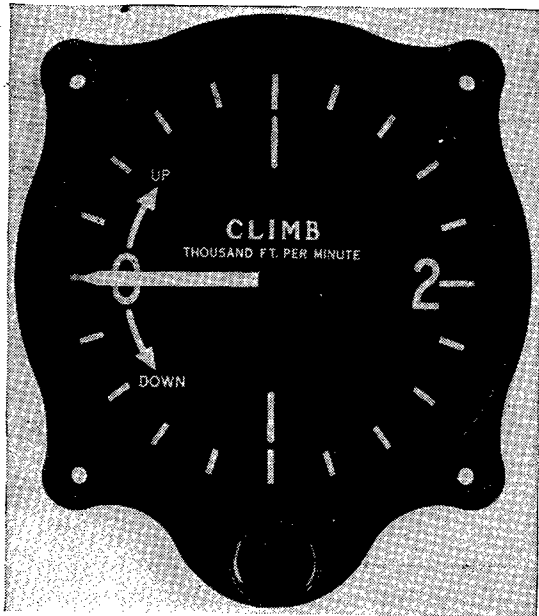

① Indicator.

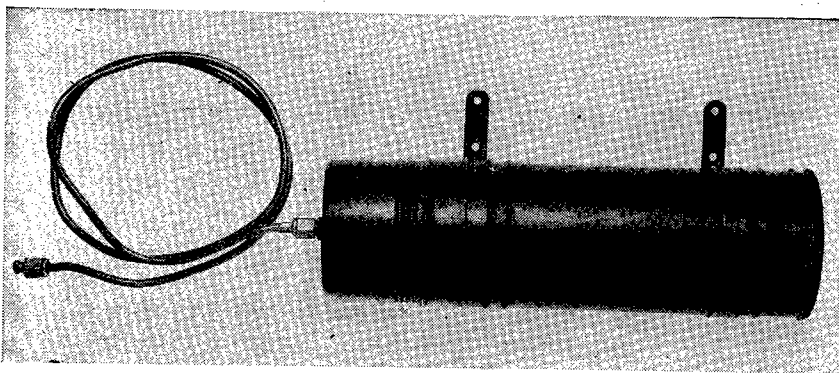

② Connecting tubing.

③ Thermos chamber.

FIGURE 68.—Rate of climb indicator with separate thermos chamber.

necting tube. The calibrated diffuser assembly *V* is also connected to the case chamber connection. The interior of the instrument case *K* is subjected to atmospheric pressure by means of the case static connection *P*. The deflection of the diaphragm is translated into pointer movement through a link, rocking shaft *R*, long lever arm *L*, sector assembly *S*, and pinion. To prevent injury to the mechanism from high pressure resulting from violent maneuvers, the diaphragm

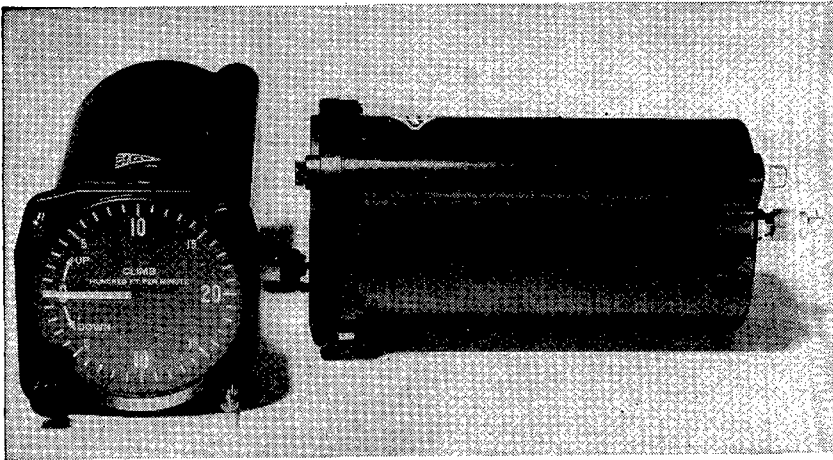

① Front view.

② Side view.

FIGURE 69.—Rate of climb indicator with integral thermos chamber.

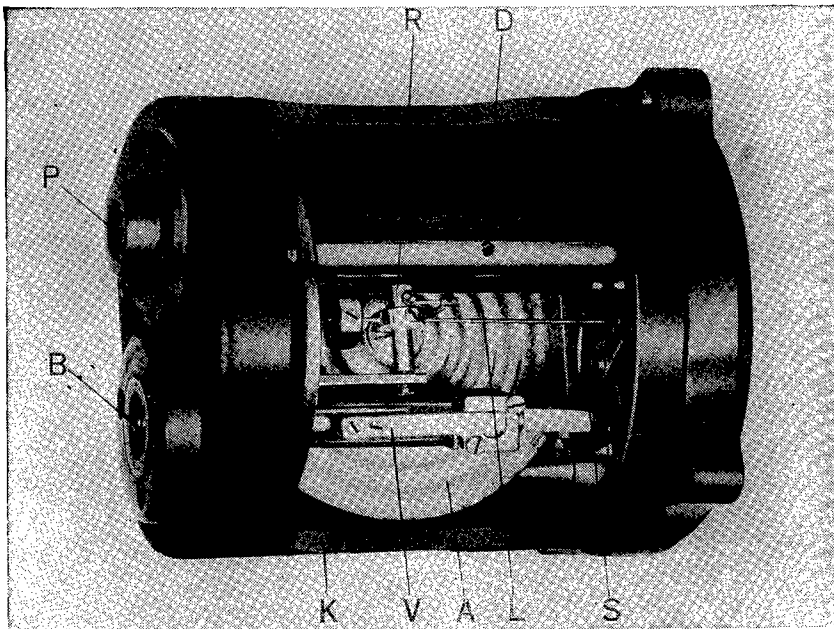

FIGURE 70.—Rate of climb indicator mechanism.

movement in each direction is limited by a stop. A knob is provided for setting the pointer on zero. The pointer movement is accomplished by changing the position of the diaphragm which is

mounted on the zero adjusting spring. This spring may be depressed or relieved by turning the knob.

c. The types having separate thermos chambers are housed in $2\frac{3}{4}$ -inch instrument cases of molded bakelite construction provided with an airtight seal, while those in which the thermos chamber is built integral with the instrument case have a two-piece case. Both are provided with the standard 3-volt ring light, the receptacle being molded integral with the instrument case.

123. Operation.—*a.* The rate of climb indicator is designed to indicate a change in altitude of an airplane in flight. In level flight the pointer is horizontal; for any rate of climb a definite pointer indication in a clockwise direction occurs. In a similar way, for rates of descent, the pointer rotates downward or counterclockwise from the zero position to indicate the rate of descent. Each instrument has a sector stop to limit the travel of the pointer for ascent and descent to 1,900 feet per minute. Rates of ascent or descent in excess of 1,900 feet per minute will not impair the operation or accuracy of the instrument.

b. The rate of climb indicator is essentially a sensitive type of manometer. It operates from the differential between atmospheric pressure and the pressure of the thermos chamber which is vented to the atmosphere through a small calibrated leak. The restriction of the leak at the exit of the chamber causes a definite pressure differential to be established between the outside and the inside of the chamber when the atmospheric pressure changes, as in ascending and descending maneuvers. The measure of this rate of change of atmospheric pressure is indicated on the dial as a rate of change in altitude in feet per minute.

c. By use of a restriction to prevent oversensitiveness caused by "bumps," all rate of climb indicators have an inherent lag ranging from 6 to 9 seconds. Pointer oscillations which will be evident under turbulent atmospheric conditions should be interpreted as the response of a very sensitive instrument to actual conditions. These oscillations are inherent and do not interfere with the practical application of the information which the instrument furnishes. Further damping by use of restrictions would increase the lag in the instrument to an undesirable extent.

124. Installation.—*a.* The general points on installation of instruments given in section III are applicable to this instrument.

b. On instruments where the thermos tank and the indicator are separate units, the tank is mounted in a horizontal position at a distance not to exceed 3 feet from the indicator in a location where it will not be subjected to sudden or pronounced temperature changes.

There are two vents on the rear side of the instrument case, each provided with a threaded nipple. The vent marked "S" is connected with the static line and the vent marked "C" with the thermos chamber. If these connections are reversed, the indications on the instrument will also be reversed; that is, when ascending, the indicator will show descent and vice versa. The tubes used to connect the indicator and tank should not be altered in length, and if greater flexibility is desired, a standard flexible hose may be placed in the line provided a like length of the copper tubing is removed. When the copper tubing is used, it should have at least one coil with a radius of not less than 2 inches to absorb vibration and permit flexibility between the indicator and the tank. The tubing should be annealed after forming. These connections must be tight as a leak of even the slightest amount at this point will cause large scale errors in the instrument.

c. On late types of climb indicators where the thermos chamber is an integral part of the indicator, only one connection to the static line is necessary.

125. **Maintenance.**—*a.* The general points on maintenance of instruments given in section II are applicable to this instrument.

b. At periodic intervals, the static system and the indicator case must be checked for leaks. This is done by setting the pointer to zero with the adjuster, breaking the static connection as close to the indicator as possible, and attaching a 2- or 3-foot length of 1/4-inch rubber tubing. Apply a slow, continuous suction which will cause the pointer to indicate 500 feet per minute for 1/2 minute, then pinch the hose and watch the pointer; it should return to zero within the inherent lag period of the instrument. If it continues to rotate past zero in the counterclockwise direction, there is evidence of a leak in the instrument case and the instrument must be removed and replaced.

SECTION XXVII

BANK AND TURN INDICATORS

	Paragraph
Purpose and use.....	126
Description.....	127
Operation.....	128
Installation.....	129
Maintenance.....	130

126. Purpose and use.—*a.* The bank and turn indicator is used for controlling the flight of an aircraft under conditions of poor visi-

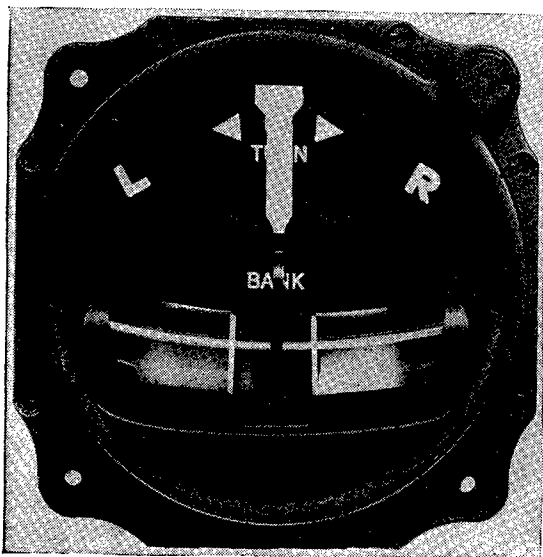

ⓐ Front view.

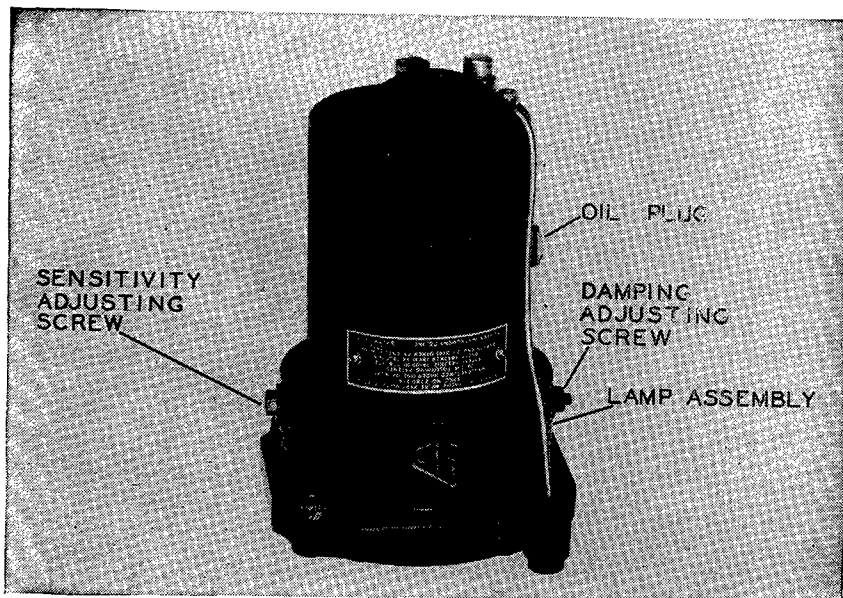

ⓑ Top view.

FIGURE 71.—Bank and turn indicator.

bility or when for any reason it is desirable to eliminate any yawing or turning.

b. Some specific uses for this instrument are to—

(1) Enable the pilot to maintain a straight and laterally level flight.

(2) Enable the pilot to make precision turns at predetermined rates.

(3) Coordinate rudder and ailerons when making banked turns.

127. Description.—*a.* The bank and turn indicator (fig. 71) is a combination of two flight instruments, the bank indicator and the turn indicator. A cross section diagram of the instrument is shown in figure 72. The turn indicator unit is a gyroscopic device which indicates

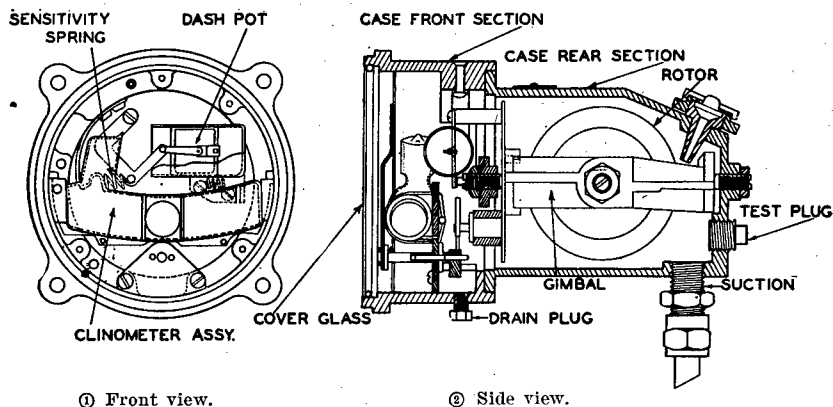

FIGURE 72.—Cross section diagram of the bank and turn indicator.

motion about the vertical axis of the airplane. It is composed of a suction-driven gyro rotor located in the rear section of the case on a restraining spring, and a dash pot for damping. The gyro rotor is carefully balanced, and runs on specially designed precision ball bearings to which oil is supplied from a reservoir within the gyro. The bank indicator unit is a simple pendulous device of the inclinometer type, comprising a black glass ball which moves against the damping action of a liquid in a curved glass tube indicating motion about the longitudinal axis. This clinometer assembly is located in the front section of the instrument case.

b. The instrument case is of the standard size, using a $2\frac{3}{4}$ -inch dial, and has incorporated into the case proper a drain plug, vacuum connections, damping adjustment, sensitivity adjustment, and lubrication opening. The drain hole and screw are located on the bottom of the

instrument just behind the mounting flange assembly to facilitate the removal of collections of water and oil from the interior of the case. One vacuum connection is located on the bottom rear, and the other at the back of the case. Both have $\frac{1}{8}$ -inch internal pipe threads and are provided with pipe plugs so that either may be removed to connect the vacuum line, depending upon convenience of the installation. The damping adjustment screw and lock nut are located on the right-hand side of the case just behind the mounting flange assembly. When this screw is turned "in," the open area of the damping orifice is increased and the damping effects decreased. The sensitivity adjusting screw and lock nut are located on the left-hand side of the case just behind the mounting flange assembly. When this screw is turned "in," the tension on the centralizing spring is decreased, permitting the "rate of turn" pointer to deflect farther for a given rate of turn. The lubricating spring is located on the right-hand side of the rear section of the instrument case and is provided with a threaded plug and a lead gasket for sealing purposes.

c. The dial is plain, having only the letters "L" and "R," the neutral mark, and an index on each side of the neutral mark. The index indicates a 1-minute turn of 360° when the pointer is coinciding with the index. Fluorescent lighting is used on latest models of this instrument.

128. Operation.—*a.* The turn indicator may be operated by an engine-driven suction pump, by suction from the engine intake manifold, or by a venturi tube mounted in the slip stream of the airplane. Sucking air from the case causes a stream of air to flow through an intake jet, driving a small gyro wheel at high speed. The gyro rotates about the lateral axis in a frame that is pivoted about the longitudinal axis. When mounted in this way, the gyro responds only to motion around a vertical axis, not being affected by rolling or pitching. The principles of the gyro assembly refer to a system of axes originating in the center of the gyro rotor shown in figure 73. The axis of rotation of the rotor is called "Y," the longitudinal axis of the frame "X," and the axis normal to these two or the vertical axis "Z." The gyro rotates at high speed as indicated by the arrow *a*. When the airplane is turning, for example, to the left, the gyro assembly is rotated as indicated by the arrow *b* as the *X* axis is fixed to the longitudinal axis of the airplane. The reaction of the gyro to this turning influence is an immediate rotation *c* about the *X* axis until *Z* has aligned itself with the original position of axis *Y* or a displacement of 90° . This movement is due to one of the fundamental principles of gyroscopes known as precession. Precession of a gyroscope is the natural reaction at right angles to an applied torque. In the turn indicator, the rotation of the gyro assembly around axis *X* acts

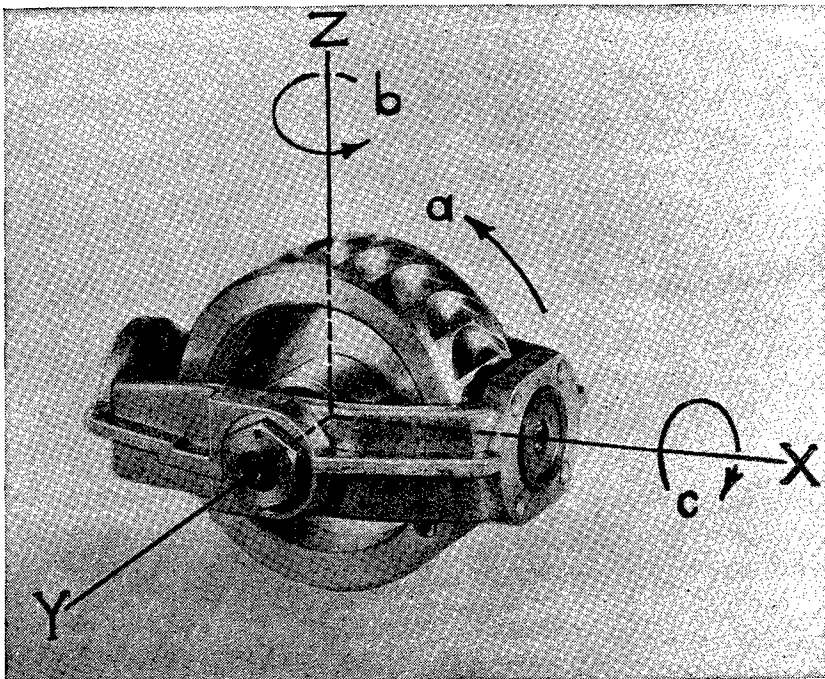
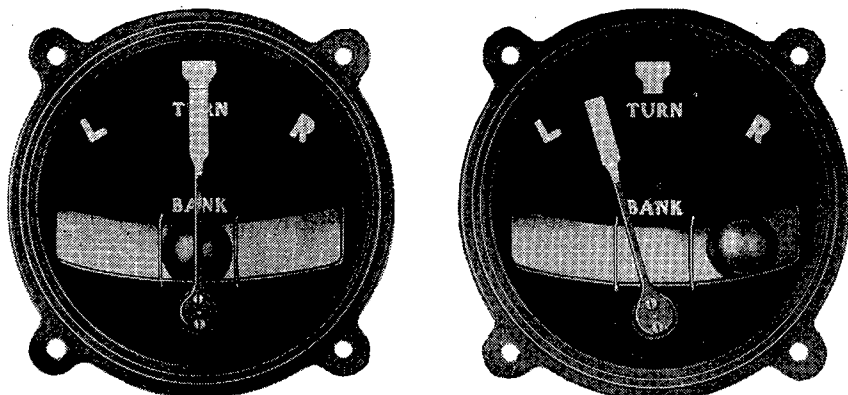

FIGURE 73.—Gyro rotor, bank and turn indicator.

against the restraining force of a spring and is limited by stops to about 45° each side of the vertical. This spring serves to balance the gyroscopic reaction during a turn and to return the assembly to its vertical neutral position as soon as straight flight is returned. The action of the gyro assembly is damped by a dash pot. An opening provided to the interior of the cylinder is controlled by a screw valve ad-gyro assembly and hand approximately proportional to the rate of gyro, spring, and damping mechanism produces a displacement of the gyro assembly and hand approximately proportional to the rate of turn of the aircraft. When centered, the hand shows that the airplane is flying straight disregarding drift, pitch, and bank. When the hand is off center, it indicates that the airplane is turning in the direction shown by the hand. The amount the hand is off center is proportional to the approximate rate of turn.

b. The bank indicator is a simple form of pendulum which indicates motion about the longitudinal axis of the airplane and is used to control the lateral attitude of the airplane in straight flight or turns. While the airplane is making a perfectly banked turn, the ball will remain in the center position due to centrifugal force. The correct bank is indicated for any turn but no indication is given of

the amount of bank. In either straight flight or turn the centered ball indicates proper lateral attitude. If the ball moves in the direction of the turn, it indicates that the airplane is slipping toward the inside of the turn due to overbanking. If the ball moves in the opposite direction, it indicates that the airplane is skidding toward the outside of the turn due to underbanking.



⊙ Straight and laterally level.

⊙ Left turn with skid.

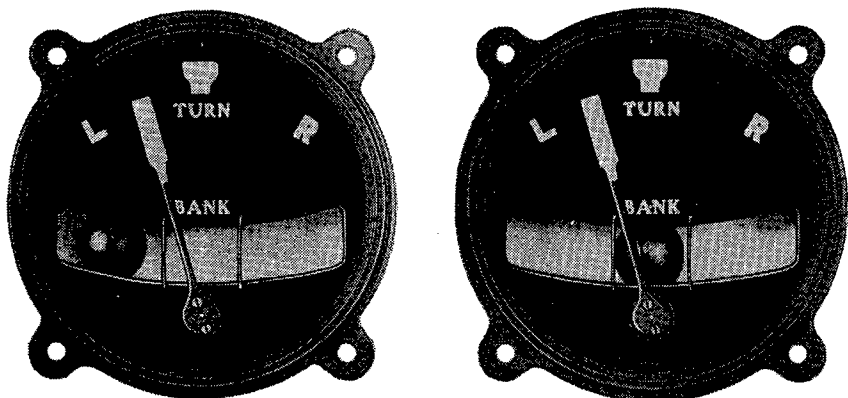

⊙ Left turn with slip.

⊙ Left turn properly banked.

FIGURE 74.—Indicator readings for several conditions of bank and turn.

c. The indications of these two instruments on the one dial serve to show at all times the rate of turn and the lateral attitude of the airplane in straight flight or turns. Figure 74 shows some examples of the bank and turn indicator readings.

129. **Installation.**—*a.* All general points on installation of aircraft instruments are applicable to this instrument. The bank and

turn indicator, grouped with other flight instruments, is mounted so that the dial is vertical when the airplane is in normal flight position and the ball of the bank indicator is in the center position. Before a new instrument or one which has been received from stock is installed, approximately six drops of a mixture of one-third compass liquid and two-thirds gyro instrument oil are added to the rotor pivot.

b. Installation is made in accordance with various airplane and instrument board drawings. When connecting the venturi tube to the indicator, the tubing should be run as straight as possible avoiding bends of small radius and may be connected to the indicator at either the lower or rear connection. The connection not used is plugged with the $\frac{1}{8}$ -inch pipe plug provided. When installed on a vibration-absorbing instrument board, a suitable length of flexible tubing (approximately 10 inches) is used. Under normal flight conditions, a suction of 1.90 inches of mercury is desired inside the case of the instrument. It is necessary to check the amount of suction after the installation is completed by connecting a suction gage to the connection which is not in use, care being taken to replace the pipe plug after the test has been made.

c. Due to varying temperatures and individual instrument characteristics, the vacuum of 1.90 inches of mercury will not always produce the desired sensitivity. The vacuum should be set to produce the required deflection wherever practical during a flight test. Adjustment of the restricting needle valve may be made by reaching under the instrument board. Increasing the vacuum (screwing the valve stem out) increases the sensitivity and amount of deflection, and decreasing the vacuum (screwing the valve in) decreases the sensitivity and amount of deflection.

130. Maintenance.—a. The general points on inspection of instruments given in section II are applicable to this instrument. Service maintenance and inspection of this instrument also includes the following tests:

(1) *Static balance test.*—The pointer must zero when the rotor is not spinning, $\pm \frac{1}{64}$ inch for any position of instrument.

(2) *Dynamic balance test.*—When the instrument is stationary in normal position and the gyro is operated under a suction of 26 inches of water, the pointer should stand at the zero mark $\pm \frac{1}{64}$ inch.

(3) *Starting friction test.*—With the instrument in normal position, stationary, and not being subject to vibration, a suction of not more than 5 inches of water should cause the gyro to rotate.

b. Lubricant is added through a lubricating opening marked "oil" on the right side of the case after the instrument has been removed from the airplane. A fine wire (approximately 0.025-inch diameter) should be used to guide the oil into the hole in the pivot. Any excess of spilled oil may be a source of unsatisfactory operation. For operating conditions in which atmospheric temperatures are above freezing (0° C. or +32° F.), add eight drops of gyro instrument oil. For operating conditions in which atmospheric temperatures are below freezing (0° C. or +32° F.), add eight drops of a mixture of one-third compass liquid and two-thirds gyro instrument oil.

c. In testing and adjusting the suction, a source of suction gage is connected to the system; on the old types at the cross in which the adjustable restriction is located, and on the new types at the plug located in the back of the instrument case. The line leading to the instrument from the suction system should have a suction of 3.75 to 4.25 inch Hg. By means of the adjustable restriction, the suction on the instrument is adjusted to 1.9 inch Hg. as closely as possible. It should never be less than 1.80 nor more than 2.05 inch Hg.

d. The screen or jet may be cleaned by first removing it from the instrument, washing it in a mixture of 50-50 carbon tetrachloride and naphtha, and drying it thoroughly. When reinserting, a wrench is not necessary; finger tight is sufficient. Any condensate and excess oil may be removed by unscrewing the drain plug. All plugs and connections must be tight in order to prevent excessive air consumption.

SECTION XXVIII

TURN INDICATORS (DIRECTIONAL GYRO)

	Paragraph
Purpose and use.....	131
Description.....	132
Operation.....	133
Installation.....	134
Maintenance.....	135

131. Purpose and use.—The purpose of a turn indicator is to establish a fixed reference for maintaining flight direction. The specific uses for turn indicators are to—

- a.* Supplement the compass in keeping a course.
- b.* Show magnitude of turn.
- c.* Aid in compensation and correction when "air swinging compasses."

- d.* Maintain alinement when making instrument landings.
- e.* Coordinate navigators' and pilots' problems of directional control.
- f.* Coordinate bombardiers' and pilots' problems when performing tactical missions.
- g.* Aid in location of radio beacon stations.

132. Description.—*a.* There are in general two types of the directional gyro turn indicators, type A (fig. 75) and type B (fig. 76).

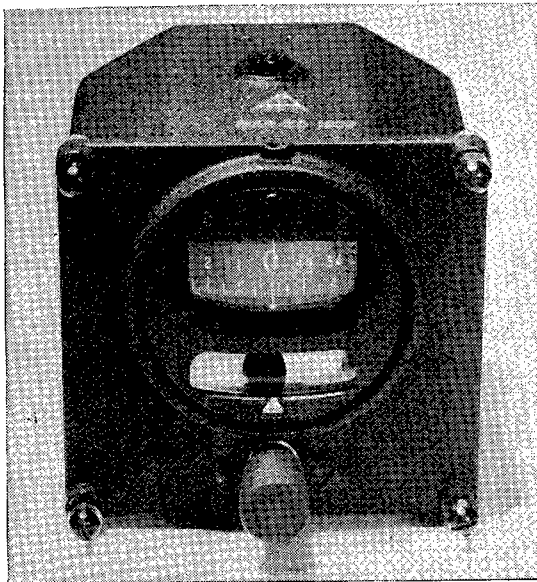

FIGURE 75.—Turn indicator, type A.

They are substantially the same except that the latter type has a pilot director feature obtained by the addition of a remote control reference card adjacent to the gyro card. This reference card is rotatable by the bomber and/or the navigator by a flexible shaft and controller.

b. The turn indicator mechanism shown in figures 77 and 78 is basically a horizontal, axis-free gyro provided with an azimuth card and setting device.

The rotor is universally mounted; that is, it is supported in a gimbal ring which is free to turn about an axis on bearings in the vertical ring. The vertical ring is free to turn about the vertical axis. The circular card which is attached to the vertical ring is observed by the pilot through the rectangular opening in the front of the instrument case. The entire assembly is supported and carried

on bearings of which the pivots are mounted in the top and bottom plates of the instrument case.

c. The caging knob protrudes through the front of the instrument case. It is used to set the gyro and card assembly on the desired

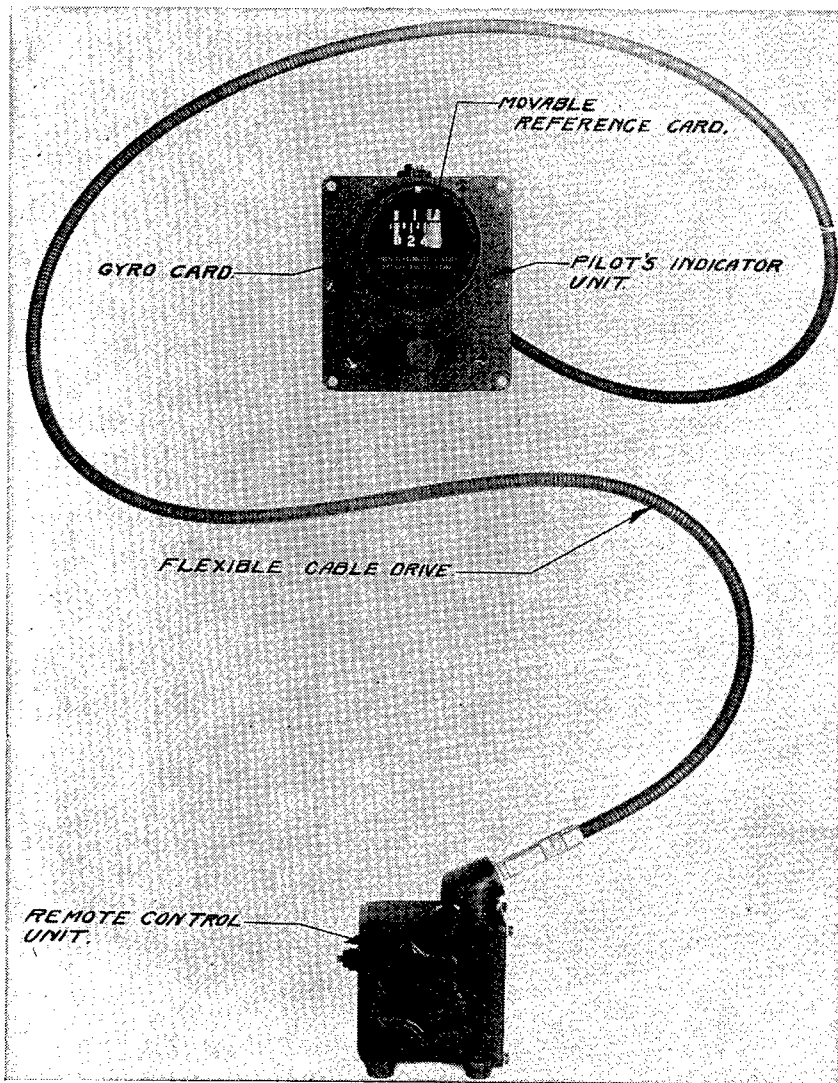

FIGURE 76.—Turn indicator, type B.

heading and to reset it at periodic intervals for course keeping when flying by compass. By pushing the caging knob "in," it engages the synchronizer lever plunger which normally rests in the cone-shaped

AIRCRAFT INSTRUMENTS

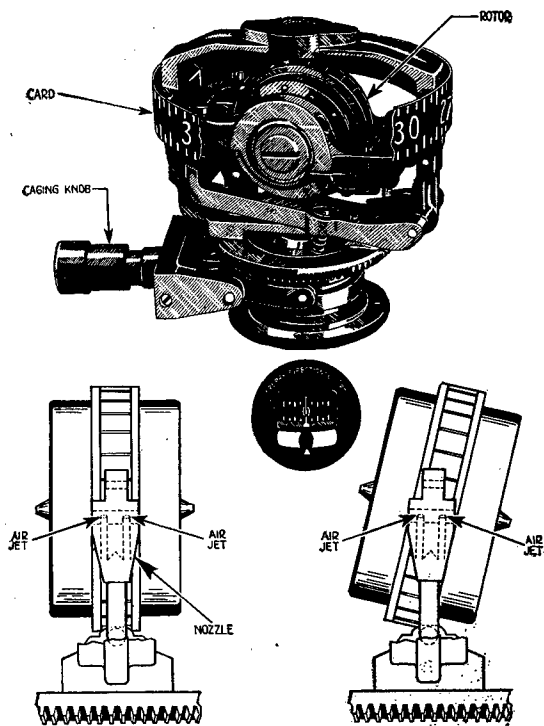
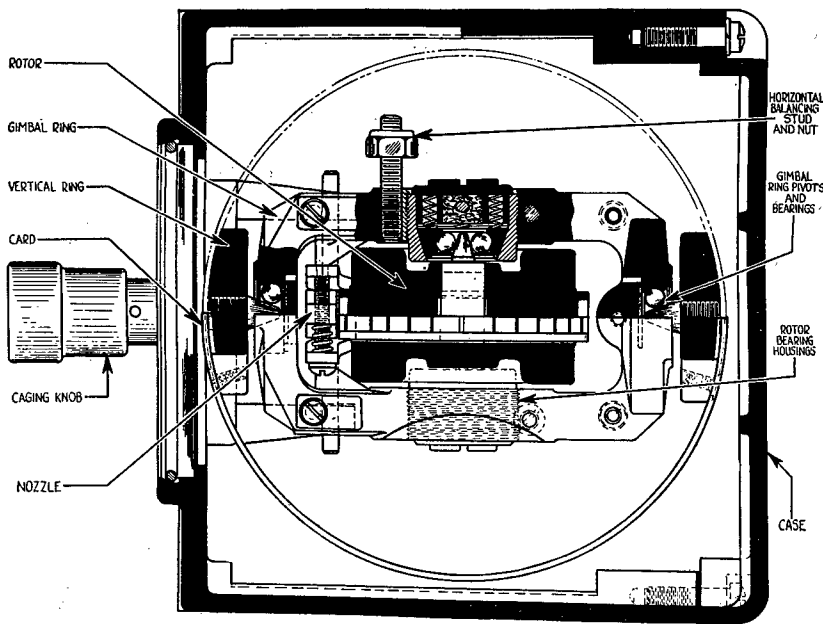

FIGURE 77.—Turn indicator mechanism.

interior of the pinion and raises the lever pins which slide in the groove of the synchronizer ring. This lifts the synchronizer ring, pushing up the spring plunger and raising the caging arm so that it makes contact with the bottom of the gimbal ring and holds the gyro horizontal as the card is turned to the desired heading. Pulling the caging knob "out" releases the caging mechanism and leaves the gyro horizontal and free.

d. The air stream which spins the rotor enters through a screened opening around the bearing pivot on the bottom plate and is divided into two parallel jets; the air from each jet is directed through nozzles onto the buckets in the rim of the rotor at points equidistant from the center. The pressure exerted by the air on the rotor circumference serves to keep it upright (fig. 77). If the rotor tilts, the air from the jet on one side strikes against the rim instead of against the buckets while air from the other jet strikes the side of the buckets causing the rotor to return to its upright position.

e. The instrument case is cast of aluminum with the front and rear plates held to it by means of flathead countersunk machine screws. The case is sealed airtight at all points except at the suction connec-



ⓐ Top view.

FIGURE 78.—Cross section of turn indicator.

tions and at the air inlet. Two $\frac{3}{8}$ -inch pipe tapped openings are located on the bottom plate near the rear for insertion of suction connection nipples. Some models are provided with a 3-volt lamp located in the front upper center of the instrument case just above the azimuth card. The connection is made with a plug located in the rear plate of the instrument case. Fluorescent lighting on all recent instruments has replaced the conventional 3-volt lighting system. All types of turn indicators in use are provided with a ball in glass clinometer located on the face of the instrument for banking purposes.

133. Operation.—*a.* The object of the turn indicator is to establish a fixed reference for maintaining flight direction. The gyroscope, which is simply a spinning wheel mounted so its axle can be pointed in any direction, affords the best way of obtaining this reference without excessive size and weight. Relative movement of the airplane in azimuth is shown on a circular card graduated in degrees.

b. The turn indicator is operated by vacuum at 4-inch Hg. supplied by means of a venturi tube or by an engine-driven vacuum pump. The rotor spinning about a horizontal axis at approximately 12,000 rpm is so mounted as to be free about the three directional axes. The card, graduated in degrees, is attached to the vertical ring

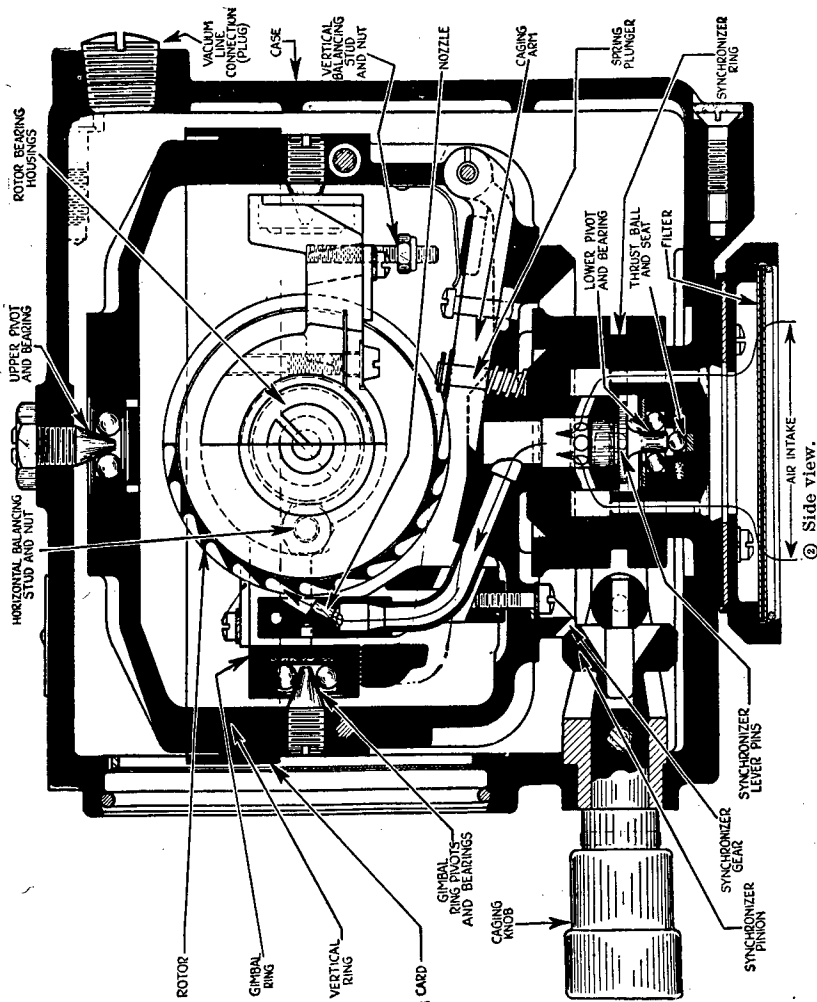

FIGURE 78.—Cross section of turn indicator—Continued.

in which the rotor and its gimbal ring is mounted. The vertical ring and card are free to turn about the vertical axis and a rectangular opening in the front of the instrument case permits a view of an ample sector of the card. The gyro axle is horizontal in normal operation. When spinning, the gyro obeys a fundamental gyroscopic principle, rigidity. Thus the rotor and gimbal ring and the card which is attached to the vertical ring remain fixed, and the airplane moves around them.

c. Unlike a compass, the turn indicator has no directive force to return it to a fixed heading. It must be checked occasionally, and if necessary, reset by means of the caging knob underneath the dial.

Pushing this knob in engages the synchronizer pinion with the synchronizer gear. By turning the knob, the card can be set by means of the reference line in the window to correspond with the compass heading or it can be set on zero when measuring amount of turn from any established heading.

d. After setting the card, pull out on the knob and the instrument is in operation thereafter unless it is either upset or recaged. Any degree of bank or pitch exceeding 55° will upset the gyro and in all probability the card will start to spin, consequently the instrument is useless until the airplane is again leveled and the gyro caged and reset. The gyro in the turn indicator should always be caged if acrobatics are to be performed. The sensitive pivots and bearings are less subject to damage and the over-all life of the mechanism before overhaul will be increased.

e. Directional control is accomplished with the directional gyro which is read in the same manner as a vertical card magnetic compass. More accurate control is possible due to the fact that the directional gyro does not swing or oscillate but remains fixed and therefore provides as positive a reference for steering as objects along a clear natural horizon. The directional gyro must be originally set to the magnetic compass and reset at intervals from 15 to 20 minutes to take up for drift of the gyro. The average drift on cardinal headings should not exceed 3° in 15 minutes and the drift on any single heading should not exceed 5° in 15 minutes. Care should be taken when setting or resetting the directional gyro, especially in rough air, to be certain that a correct compass reading is obtained. It must be remembered that even when flying straight in rough air, the magnetic compass will swing to a certain extent. When the magnetic card appears to be still, it is actually at the end of a swing and therefore farther from true magnetic azimuth. If the directional gyro is set to the magnetic compass at one end of a swing and observed a short time later in connection with the compass when the compass is at the opposite end of a swing, it will seem as though there had been an excessive drift of the gyro. To avoid this trouble, the airplane should be held as straight as possible for about a minute by a directional gyro setting, approximately the same as the compass reading, during which time the compass may be observed to determine its average reading during swings, and the directional gyro then properly set. When uncaging the gyro after setting, the caging knob should be pulled straight out.

134. Installation.—*a.* The general points on installation of instruments given in section III are applicable to this instrument. In general, gyroscopic flight instruments are installed as shown in

figure 4 and require the installation of an engine vacuum pump. Venturi tubes are installed as an alternate source of suction on single-engine airplanes. The two-engine airplanes, however, are provided with an engine-driven vacuum pump on each engine. In either case, a suction control valve is provided to permit changing from one source of suction to the other when necessary. In those cases where no vacuum pumps are available, it will be necessary to use venturi tubes for the main source of suction. However, due to the insufficient suction in glides and the possibility of the venturi freezing and becoming inoperative, satisfactory operation cannot be expected from a venturi tube as the main source. Venturi tubes are mounted as indicated by the arrow on the name plate, in the slip stream of the propeller as close as possible to the instrument it is to operate, so as to keep the length of connecting tubing to a minimum. The venturi tube must produce a vacuum of not less than 3 inches and not more than 5 inches Hg. at the instrument when the airplane is flying at cruising speed. The ideal vacuum is 4 inches Hg. at cruising speed.

b. In view of the delicate construction of gyroscopic instruments, they are only installed on vibrationproof instrument panels. The turn indicator is fitted with self-locking nuts so that it is only necessary to insert the four attaching screws from the front and tighten them with a screw driver. It is essential that each instrument is properly leveled on installation. With the airplane in its normal flight attitude, place a spirit level across the face of the instrument to see that it is level longitudinally and laterally. If necessary, shims may be added (the same thickness on each side) between the turn indicator and the panel at top or bottom as required. By slightly elongating the holes in the instrument panel, the turn indicator can be tilted one way or the other sufficiently to make it level. Before tightening the screws, be sure that all four corners of the instrument touch the panel surface or shims (if any have been added) in order that the instrument will not be strained when the screws are tightened. The turn indicator is removable without disturbing any of the other instruments and under no circumstances should support attachments be made except by screws through the mounting lugs.

c. Standard Air Corps fittings and tubing are used when installing the instrument, using the most convenient of the two connections on the case and taking care to see that the one not used is kept tight. On types A and B turn indicators, a terminal is provided on each side of the top front of the case for connecting the card lamp incorporated in this instrument to a source of electrical supply. The

lamp is connected in parallel with the compass light, using a radio shielded cable. On the late type turn indicators, the lighting wires are self-contained in the instrument and to make connections to the lamp it is only necessary to remove the small brass screw cap from the boss on the rear cover and screw in a shielded electrical connector plug, using a ferrule assembly with $\frac{1}{4}$ -inch flexible conduit.

d. When the installation is completed, the vacuum must be checked in flight by means of a suction gage. On fast airplanes where excessive suction is created by the venturi tube, a relief valve must be placed in the air line as close to the panel as possible, and adjusted to produce a vacuum equal to 4 inches Hg. at the instrument. For turn indicators which are to be operated by an engine-driven vacuum pump, a relief valve is supplied as part of the pump or as an accessory to the pump in order to regulate the vacuum at the instrument. Air filters are provided with all turn indicators and require occasional cleaning; this is especially true when operating in localities which are exceedingly dusty.

135. Maintenance.—General information on maintenance of instruments given in section II applies to the turn indicators. Some specific information applicable to the maintenance of turn indicators is as follows:

a. Improper operation is usually caused by excessive vibration or improper supply of vacuum. If the turn indicator does not function properly, the vibration of the instrument board and the vacuum supply are checked before removing the instrument from the airplane. If the trouble is found to be due to conditions within the instrument, it should then be removed and replaced with one that is serviceable.

b. The shafts, pivots, and ball bearings of the instrument are lubricated before assembly in the case at the factory or Air Corps repair depots and no further lubrication will be accomplished by service activities with the exception that if the caging knob is hard to pull out or push in and turns excessively hard, add a few drops of instrument oil to the surface of the shaft that passes through the front plate of the instrument case.

c. The frequency of cleaning the air intake filter will depend upon the service conditions. To clean the intake filter on the bottom of the case, the snap ring and screen are lifted out with a scribe. It is not necessary to remove any screws. The filter is cleaned with carbon tetrachloride, dried, and replaced. When cleaning a filter, it should be thoroughly examined and if found defective replaced with a new one.

d. This instrument is equipped with the conventional 3-volt lamp, therefore its removal and replacement is the same as for all instru-

ments equipped with the individual lamps. In this connection, when checking the light for operation, the compass light and turn indicator light are connected together on a separate circuit and controlled by a separate rheostat; therefore, an "on" and "off" operation will be simultaneous.

e. The correct functioning of this instrument can be checked in position by the use of two test procedures, the coast test and the drift test. The coast test indicates the condition of the rotor and gimbal ring bearings while the drift test checks the balance of the assembly and the condition of the vertical ring bearings.

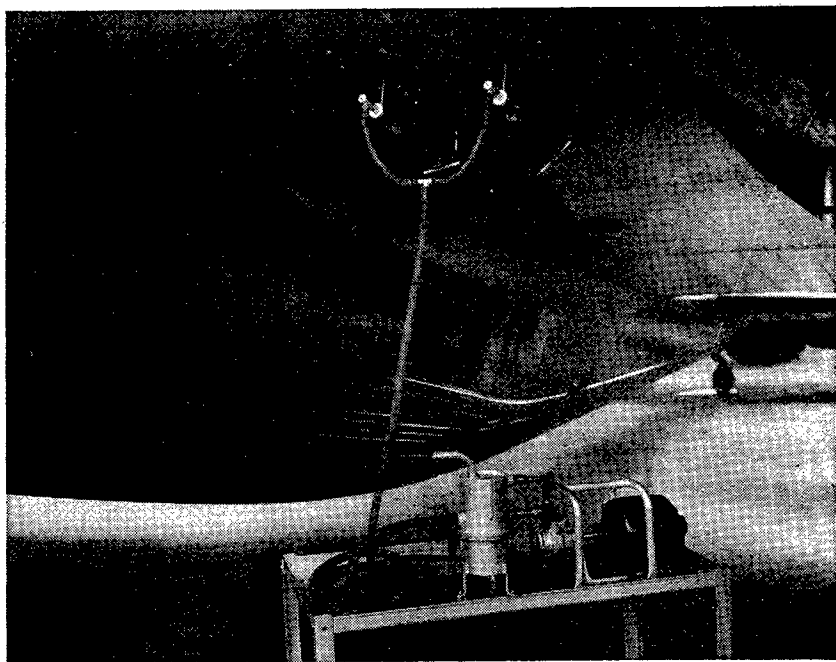

FIGURE 79.—Testing installed gyro instruments using a portable vacuum pump.

(1) In the coast test procedure, the gyro is operated for at least 5 minutes on the proper amount of suction which is then shut off by stopping the engine. After 8 minutes, a check is made to see if the gyro is still running. This can usually be determined by placing the ear close to or on some surface of the instrument case. Any instrument in which the gyro coasts less than 8 minutes should be replaced by a serviceable one.

(2) In the drift test procedure, by operating the engine vacuum pump or by connecting a portable vacuum pump into the suction system, the gyro in the turn indicator is run on the proper suction

for 10 minutes on each of the cardinal headings; that is, 0°, 90°, 180°, and 270°. With the airplane in a tail-down position, the card on the gyro should not drift off more than $\pm 4^\circ$ in the 10-minute interval on any of the headings. Figure 79 shows the portable pump connected through the venturi system; the same results may be obtained by disconnecting the line at the engine vacuum pump and connecting the portable pump there, provided the selector valve in cockpit is set to correspond with the source of entry into the vacuum system.

SECTION XXIX

FLIGHT INDICATORS

	Paragraph
Purpose and use.....	136
Description.....	137
Operation.....	138
Installation.....	139
Maintenance.....	140

136. Purpose and use.—*a.* As the natural horizon is the reference which a pilot instinctively uses in flight, the gyro horizon indicator (fig. 80) was designed to afford an artificial horizon within the cock-

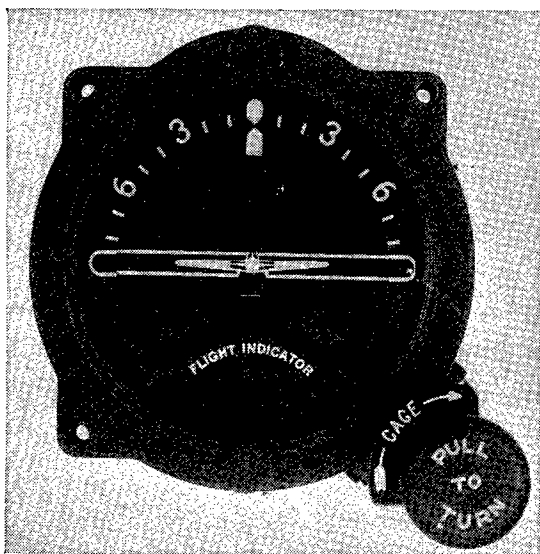

FIGURE 80.—Flight indicator with caging knob (front view).

pit of the airplane. By means of a miniature airplane and a gyro-actuated horizon bar it provides the pilot with a simulation of what he would normally see outside the airplane.

b. Some specific uses of the flight indicator are to—

(1) Supplement the pilot's sense of balance so that when flying blind he can keep the airplane properly oriented by visual reference to this instrument.

(2) Show at all times the attitude of the airplane's flight with reference to the real horizon and consequently the ground underneath.

(3) Maintain the proper glide angle during the approach to the runway when making an instrument landing.

(4) Measure the amount of bank when making precision turns.

137. Description.—*a.* The mechanism of this instrument consists of a small gyro rotor assembly (fig. 81) positioned so that the axle

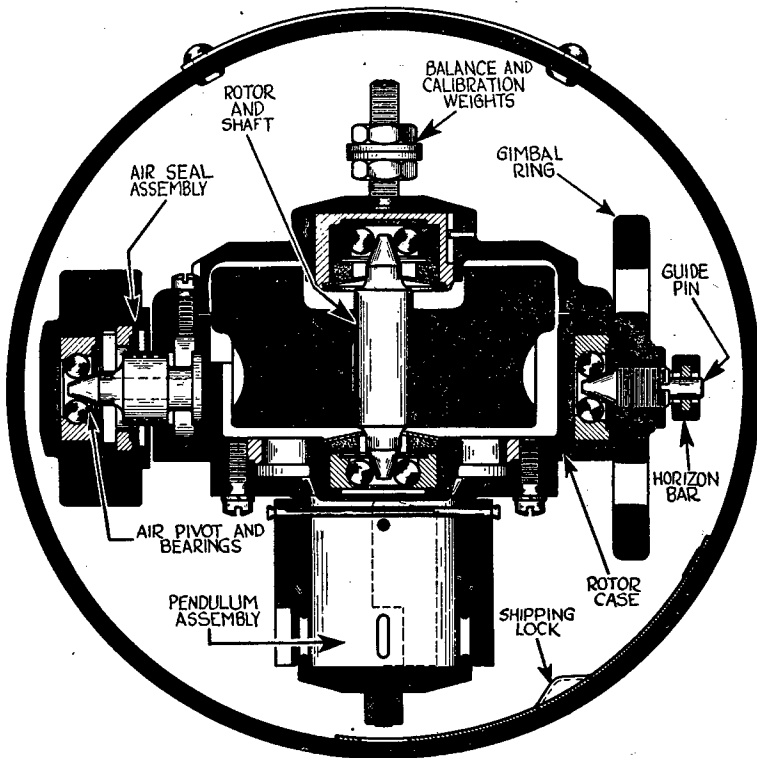

FIGURE 81.—Flight indicator rotor assembly.

of the rotor is vertical. The plane of spin is horizontal and the movement of the gyro is transmitted to the face of the instrument by a horizon bar which is actuated by a pin protruding from the gyro case through a slot in the gimbal ring as shown in figure 82. The air that spins the gyro is exhausted in four horizontal jets and through four openings spaced equidistant at the bottom of the gyro case. Pendulous

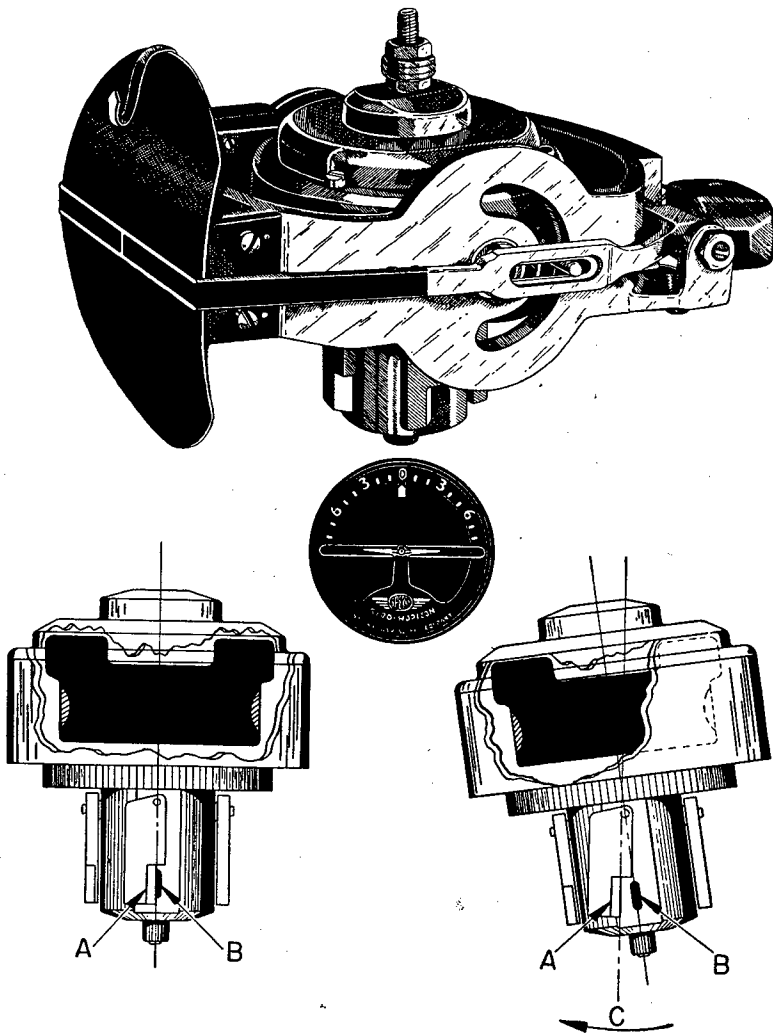

FIGURE 82.—Flight indicator mechanism.

vanes hang down over these openings and when the gyro axle is vertical, each covers half of its corresponding angle. The horizon bar is covered with luminous material to make it visible at night and the dial is finished in a satin black. A pointer is attached to the dial to indicate the amount of bank. The banking scale is marked in degrees and is mounted as a fixed part of the cover glass and front plate. Both the banking indicator, pointer, and its scale are also covered with luminous paint. The dial is an integral part of the gimbal mount and follows the precessional movements of the rotor. The image of a small air-

plane is imposed on the face of the instrument and is adjustable in the vertical plane to suit the eye level of the pilot. It is a fixed image and its attitude is always that of the airplane on which the instrument is mounted.

b. The instrument case is an aluminum casting with removable front and rear plates for insertion and removal of the mechanism. Four mounting lugs with self-locking lug inserts are provided for mounting purposes on the panel. These instruments are provided with the caging device operated by the caging knob, shown in figure 80. By pulling out on the knob which protrudes through the opening on the instrument panel at the lower right-hand corner of the instrument and rotating it clockwise, the caging arms in the instrument case cause the rotor and gimbals to assume a straight position in the lateral and

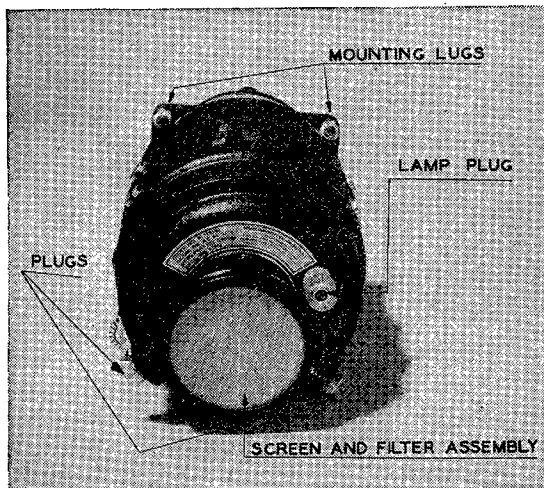

FIGURE 83.—Flight indicator (rear view).

horizontal planes. After turning the knob, the instrument can be locked in the caged position by pushing in on the knob. The lighting of this instrument is consistent with approved illumination of instruments as discussed in section I. All models are provided with tapped openings in the rear of the case for attachment of the suction connections. When the instrument is not installed, $\frac{3}{8}$ -inch pipe plugs are screwed into the openings to keep out dirt as shown in figure 83. This figure also shows the air filter assembly mounted on the rear of the case.

138. Operation.—*a.* The flight indicator is operated by a vacuum of 3.75 to 4.25 inches Hg. supplied by means of a venturi tube or by an

engine-driven vacuum pump. When the suction on this instrument is supplied from a venturi tube, 3 to 4 minutes are required after take-off to permit the gyro to attain its necessary speed. The gyro in the case spins at approximately 12,000 rpm about a vertical axis. The path of the air that spins the gyro may be traced by the arrows in the cross section view of the indicator (fig. 84). The gyro obeys a funda-

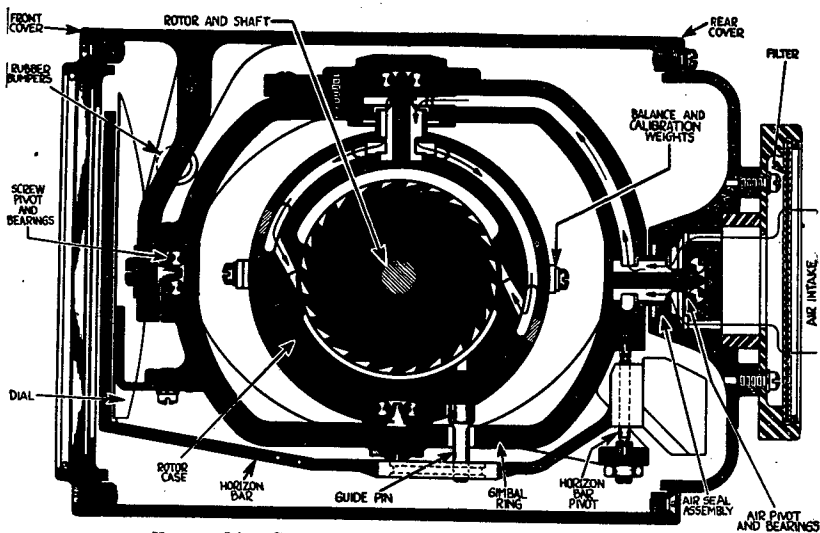

FIGURE 84.—Cross section of flight indicator (top view).

mental gyroscopic principle, rigidity in space. An indication from the gyro is picked up and brought around to the face of the instrument in the form of a horizon bar which is actuated by a pin protruding from the gyro case through a slot in the gimbal ring.

b. Any tendency of the gyro to depart from its true position due to acceleration forces or friction is corrected by a pendulous device which constantly maintains the axle in its vertical position. This device is shown in figure 82. Four pendulous vanes *A* are suspended from the under side of the gyro housing. Each one of these vanes partially covers one of the four air ports *B* that exhaust the air from the gyro compartment. If the gyro departs from its upright position, gravity holds the vanes vertical and one vane closes one port as shown at the left, while the opposite vane completely opens its port as shown at the right. The reaction of the air from this open port moves the gyro in the direction *C* back to its normal position. The gyro is held within a fraction of 1° at all times.

c. The flight indicator is air-driven and contains no magnets. It is entirely free therefore from electrical troubles and is unaffected by

magnetic disturbances. The flight indicator provides a horizon bar which remains coincident with the natural horizon through all of the usual maneuvers, banks, climbs, glides, and turns. It has no time lag and the pilot can manipulate his controls to bring the airplane to any desired attitude by noting the relation of the miniature airplane with reference to the horizon bar. By following the position of the horizon with reference to the image on the cover glass, the longitudinal and lateral attitude of the airplane relative to the real horizon and ground can be seen.

d. The limits of operation of the flight indicator are 60° pitch and 90° bank. Any time the attitude of the airplane exceeds these limits from the horizontal around either or both the longitudinal or lateral axes, the instrument will be upset and its indications are erroneous. When this occurs, the instrument can be caged which properly levels the mechanism, and when the caging mechanism is withdrawn, the instrument is ready to use again. The whole operation of caging and uncaging requires about 30 seconds.

139. Installation.—*a.* The general points on installation of instruments given in section III are applicable to this instrument. The following specific information is necessary for the proper initial or replacement installation of flight indicators. A typical vacuum installation containing a flight indicator is shown in figure 4. A suction control valve is provided to permit changing from one source of suction to the other when necessary. In those cases where no vacuum pumps are available, it will be necessary to use venturi tubes for the source of suction. However, due to insufficient suction in glides and the possibility of the venturi freezing and becoming inoperative, satisfactory operation cannot be expected from a venturi tube as the main source of suction. The venturi is mounted as described in section XXVIII.

b. In view of the delicate construction of gyroscopic instruments, they are installed only on vibrationproof instrument panels. The flight indicator is fitted with self-locking nuts so that it is only necessary to insert the four attaching screws from the front and tighten them with a screw driver. This instrument is removable without disturbing any of the other instruments and under no circumstances should support attachments be made except by screws through the mounting lugs. It is essential that each instrument is properly leveled after installation. With the airplane flying in calm air in its normal flight attitude, the instrument is adjusted on the panel so that it is exactly level longitudinally and laterally. If the face of the flight indicator is not exactly vertical, the four attaching screws may

be removed and shims added (the same thickness on each side) between the flight indicator and the panel at top or bottom holes as required to line up the horizon bar with the indices at each side. By slightly elongating the holes in the instrument panel, the flight indicator can be turned right or left sufficiently to aline the pointer with the index at the top of the dial. If facilities are available, the instrument may be leveled without flying the airplane as shown in figure

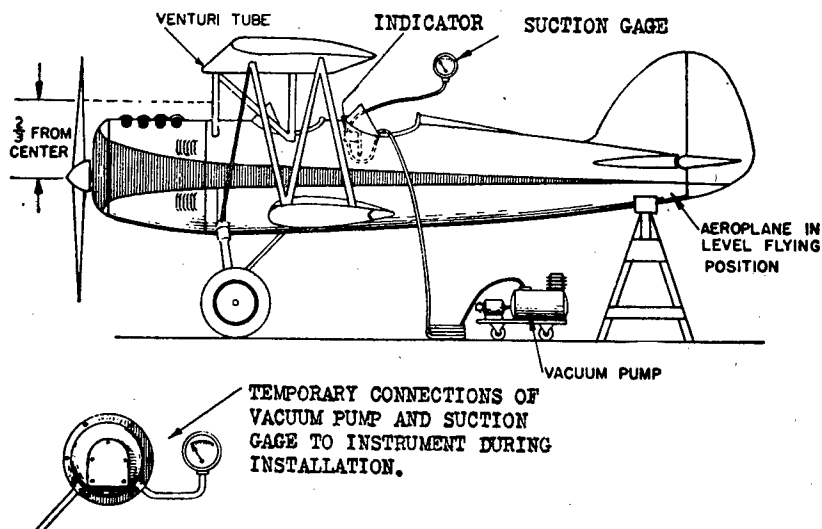

FIGURE 85.—Plan for leveling and testing flight indicator installation.

85. In this case, the tail of the airplane is raised until it is in normal flying position which is checked with a spirit level to insure that the airplane is level longitudinally and laterally. The instrument may then be adjusted on the panel as described above. A vacuum pump adjusted to supply a vacuum equal to 4 inches Hg. is used to operate the instrument.

c. When the installation is completed, the vacuum must be checked in flight by means of a suction gage. On fast airplanes where excessive suction is created by the venturi tube, a relief valve is placed in the air line as close to the panel as possible, and adjusted to produce a vacuum equal to 4 inches Hg. at the instrument. For flight indicators which are to be operated by an engine-driven vacuum pump, a relief valve is supplied as a part of the pump or as an accessory to the pump in order to regulate a vacuum at the instrument.

140. Maintenance.—a. The general points on maintenance given in section II are applicable to this instrument. In addition, there are

a number of specific points and procedures applicable to flight indicators. These instruments will operate for approximately 1,000 hours under normal operating conditions without cleaning or renewal of oil. However, continued operation in hot climates or under other adverse conditions necessitates more frequent periods of cleaning and lubricating. Since cleaning and lubricating are not functions of service activities, the gyroscopic instruments are not removed for this reason until the airplanes are sent to repair depots for overhaul. Upon overhaul of the airplanes, these instruments are inspected by the depot and given any necessary servicing and reinstalled or replaced with serviceable instruments. However, where gyroscopic instruments are removed from the airplane between overhaul periods because of malfunctioning and found to be unserviceable, they are forwarded immediately to the repair depot where they are repaired or replaced with serviceable instruments.

b. The frequency of cleaning air intake filters will depend upon service conditions. The procedure is first to remove the snap ring and screen at the back of the case. The filter is then washed with carbon tetrochloride, dried, and replaced. When cleaning a filter, it should be thoroughly examined for defects and rejected if any are found.

c. The suction is checked by using the suction gage on the instrument panel and when adjustment is necessary it is made with the suction relief valve in the vacuum system. When the suction is first applied, the horizon bar will oscillate sometimes violently which is a normal reaction. However, all oscillation should cease and the bar settle and hold a steady position after the expiration of 1½ minutes. The banking indicator must always be perpendicular to the horizon bar; that is, if the bar is cocked to left or right, the banking indicator is off of zero the same amount in the same direction.

d. The coast test on a flight indicator can be made any time after the engines have been running for at least 10 minutes so that the instrument has been running for at least 5 minutes at normal speed on 3.75 to 4.25 inches Hg. When the suction is cut off, the gyro must coast for at least 8 minutes. By placing the ear on the cover glass of the instrument, any rotation of the gyro can be detected. Any flight indicator failing on this test is removed and replaced with a serviceable one. In performing ground checks on installed flight indicators, a portable vacuum pump is used and connected into the airplane vacuum system as described in section XXVIII.

SECTION XXX

AUTOMATIC PILOT, TYPE A-2

	Paragraph
Purpose and use.....	141
Description.....	142
Operation.....	143
Installation.....	144
Maintenance.....	145

141. Purpose and use.—*a.* The purpose of the automatic pilot is to provide a mechanical means for automatically controlling the flight attitude of an airplane. By its use the human pilot can be relieved of strain and resultant fatigue when manually flying an airplane, particularly on flights of long duration. It also allows the attention of the human pilot to be devoted to navigation and tactical problems, engine operation, or other important flight factors.

b. In addition to maintaining mechanical control, the automatic pilot furnishes visual indications of the attitude of the airplane in yaw, pitch, and bank similar to the indications of the flight indicator and the turn indicator.

c. While the automatic pilot is used normally to maintain straight and level flight, it may also be used for all of the normal maneuvers of flight such as climb, descent, flat turns, spirals, etc., with greater precision than is possible by a human pilot.

142. Description.—*a.* The automatic pilot consists of a combination of gyroscopes, pneumatic and hydraulic actuated mechanisms which, when their functions are coordinated, simulate the operation of the human brain, nerves, and muscles. The mounting unit consists of a frame to which the air relays, balanced oil valves, follow-up pulleys, exhaust and drain manifolds, vacuum lines, and electrical contacts are attached as shown in figure 86. The two control boxes, directional gyro unit, and bank and climb gyro units (fig. 87) are carried by the mounting unit. The control units slide into place on tracks and are easily secured by inserting four screws. They are interchangeable with other like units, but their construction makes it impossible to place them on the wrong track or to interchange them with each other. Twelve-volt lamps are used for illuminating the dials of the directional and bank and climb gyro controls. Access to these lamps may be had through a small door on the front of each control unit. Two spare bulbs are carried behind the door on the bank and climb gyro control for use as replacements in case one of the lamps burns out. When the control units are placed on the tracks and secured, all the necessary connections

AIRCRAFT INSTRUMENTS

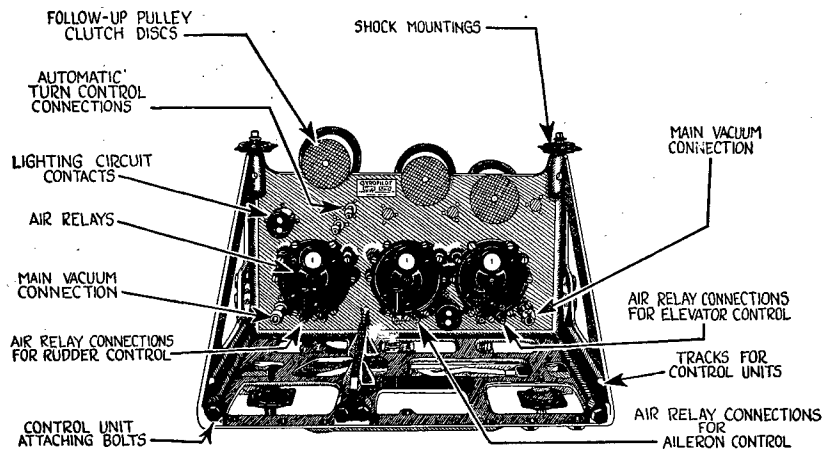

① Front view.

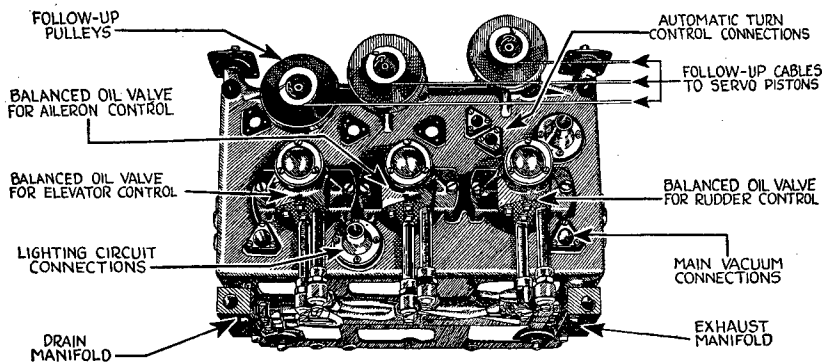

② Rear view.

FIGURE 86.—Automatic pilot mounting unit and attachments.

are made automatically by contact at the rear of each unit and the front of the mounting unit.

b. The directional gyro control (rudder) (figs. 87 and 88) contains the directional gyro mechanism, rudder knob, follow-up card, directional gyro card, ball bank indicator, and caging and setting knob. This unit slides into its respective track on the left side of the mounting unit and is secured by two screws. The bank and climb gyro control unit (figs. 87 and 89) contains one rotor which maintains the lateral and longitudinal attitude indication and control. The unit also contains the air pick-offs, follow-up systems, caging knob, control knobs, a vacuum gage, and level flight control. It slides into its

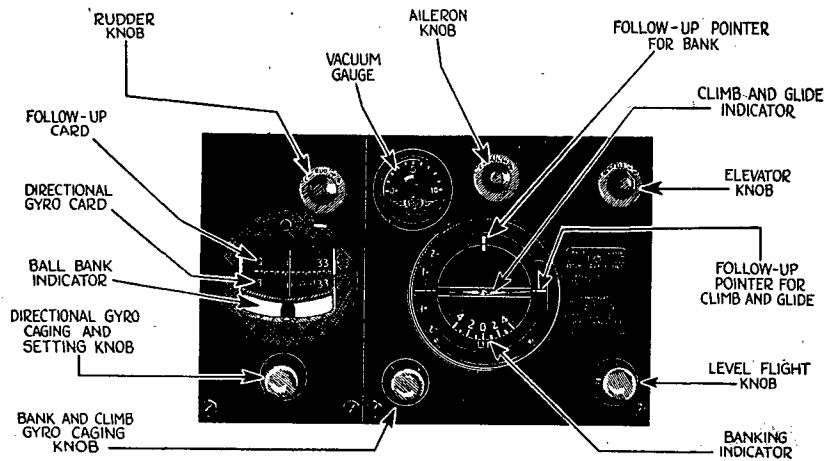

① Front view.

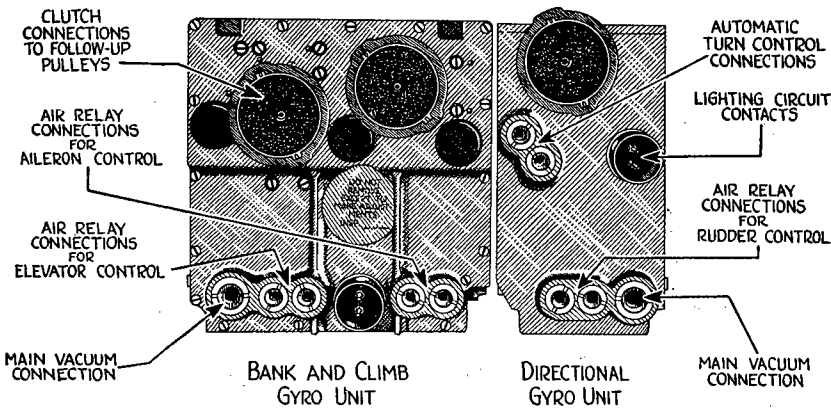

THE CONTROL UNITS SLIDE INTO THE MOUNTING UNIT ON TRACKS AND THE CONNECTIONS ENGAGE AUTOMATICALLY AS THE ATTACHING BOLTS ARE TIGHTENED

② Rear view.

FIGURE 87.—Automatic pilot gyro control units.

position on the right-hand side of the mounting unit and is also secured by two screws.

c. Figure 90 shows the component parts of the complete automatic pilot and their relation to each other and to the control surfaces of the airplane. A brief description of each unit is as follows:

(1) The on-off valve Z located in the hydraulic surface control is operated by the engaging lever, which is located on the control column in the pilot's cockpit. To engage or disengage the automatic pilot

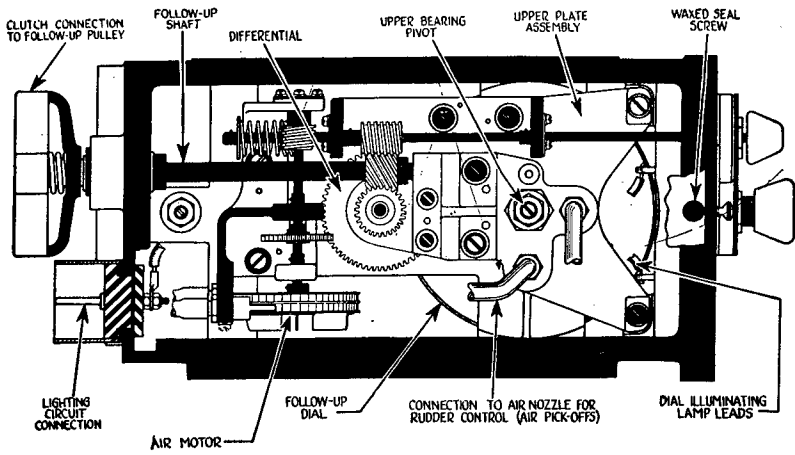

① Top view.

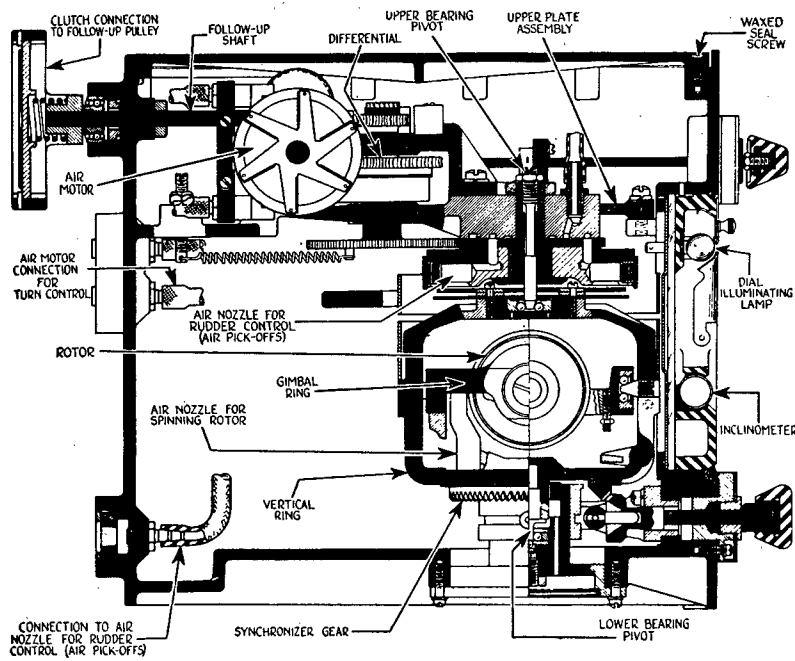

② Side view.

FIGURE 88.—Cross section of a directional control unit.

from the control surfaces of the airplane, the lever is set to the on or off position, respectively.

(2) The oil sump *O* is an oil reservoir for the hydraulic system and has a capacity of about 1½ gallons.

AIR CORPS

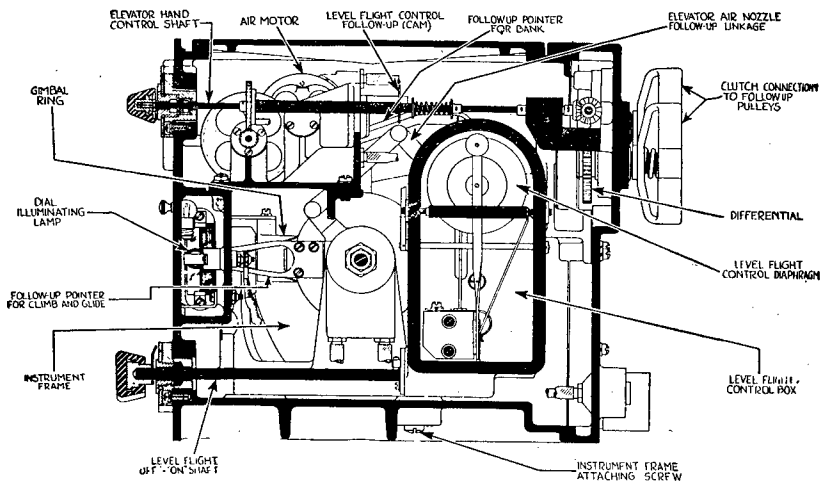
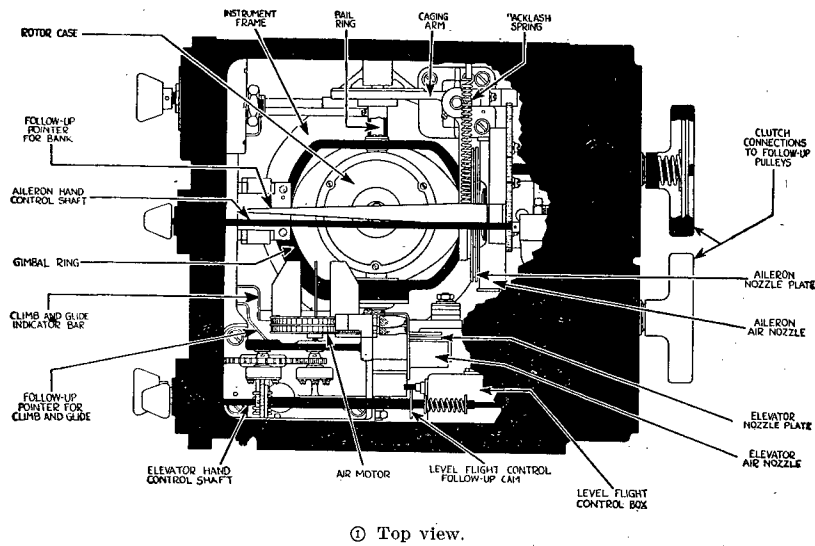

FIGURE 89.—Cross section of a bank and climb unit.

(3) The engine-driven oil pump *J* provides the necessary pressure and flow of oil for operating the automatic pilot. Pump bases are provided to fit various types of standard engines. One-half horsepower is required for the pump. Its capacity is 3 gallons of oil per minute.

(4) The oil pressure regulator *N* is a spring-loaded ball type regulating valve connected on the pressure side of the pump in a posi-

tion to permit easy access to its adjusting screw and lock nut. When properly set after ground tests, further adjustments will seldom be needed. On equipment in which the hydraulic system is interconnected with other hydraulic applications, such as landing gear and flaps, no sump is supplied. In this case a special pressure relief valve is used.

(5) The oil pressure gage *W* indicates the pressure at which the oil is being supplied to the automatic pilot. This is a conventional Bourdon tube pressure gage with a range of 0 to 300 pounds per square inch.

(6) The bypass valve *VV* allows the output of the hydraulic pump to be applied to the main system or merely to circulate around the pump.

(7) Speed control valves *Y* control the speed of the action of the hydraulic surface controls by regulating the rate of flow of the oil which actuates them. There is one speed control valve for each surface control.

(8) The oil relays *H* are five port valves each provided with a four-step piston. One passage of the valve provides a channel for the passage of oil under pressure from the speed control valve. Two of the ports lead to the servo unit. One of the ports provides a means for drainage and the other for exhaust. The piston is balanced by means of a spring located at one end. Means are provided for a very sensitive adjustment of the spring tension.

(9) The hydraulic surface controls *K*, which make up the servo unit, are mounted permanently and connected in or to the airplane control system. Each unit consists of three hydraulic cylinders, one for each surface control. The speed at which the pistons move may be regulated by the rate of flow of oil from the oil relay to the servo cylinder. Each control is made up of a piston within a cylinder. The piston is attached to the center of a long piston rod which extends outside of each end of the cylinder and to each end of which is attached the cable controlling the movement of a control surface using turnbuckles *L* and *L'*. Oil pressure acting on one side or the other of the piston under the direction of the balanced oil valves in the mount assembly controls the movement of the surface control cables. Integral with each cylinder is a relief valve which is normally set for a pressure of about 25 pounds per square inch more than the operating pressure. In an emergency, if for any reason it is impossible to disengage the automatic pilot from the airplane controls, the pilot can, by exerting excessive pressure on the stick or rudder,

overpower the automatic pilot and take over control of the airplane manually.

(10) The oil drain trap *X* is connected between the drain manifold on the mount assembly and the suction line to the oil pump. On an alternate installation which omits the drain manifold, the oil drain trap is connected between the oil drain outlets on the balanced oil valves of the mount assembly and the suction line to the oil pump.

(11) The main oil filter *V* is located in the reservoir.

(12) The auxiliary oil filter *ZZ* is connected in the main oil pressure line between the pump and the speed control valves. The filter element can be withdrawn for cleaning without the necessity of disconnecting any piping or fittings.

(13) The drain manifold *I* is connected between the drain outlets of the balanced oil valves on the mount assembly and the oil drain trap. It is secured to the base of the mount assembly with two screws. On an alternate installation, the drain manifold may be omitted. In this case, the drain outlets are connected directly to the oil drain trap.

(14) The exhaust manifold *XX* is connected between the exhaust outlets of the balanced oil valves on the mount assembly on the oil pump side. It is secured to the base of the mount assembly with two screws.

(15) The vacuum pump *B* is engine-driven. It furnishes the source of suction which operates vacuum-actuated units of the control system.

(16) The suction or vacuum gage *U* is an integral part of the bank and climb gyro control unit and shows the amount of vacuum in the control system. It has a graduated range of 0 to 10 inches Hg.

(17) The suction regulator *T* is connected in the air line between the vacuum pump and the mounting unit.

(18) Each air pick-off system *A* and *A'* consists of the air nozzle and the air nozzle plate. The nozzle plate is secured to and is part of the vertical ring. Inasmuch as the vertical ring is held in position due to the property of the gyroscope's rigidity, then likewise the air nozzle plate will remain rigidly in the same plane unless the entire mechanism is turned manually. The air nozzle is pivoted above the vertical ring but is not part of it. It is free to rotate about the same axis of the airplane in relation to the control surface associated with it. The air nozzle has a small slot approximately $\frac{1}{2}$ inch long and $\frac{1}{64}$ inch wide and is supported above the air nozzle plate, the distance between the two surfaces being 0.000017 inch.

AIRCRAFT INSTRUMENTS

With such a minute opening, the air passing between the air nozzle and the air nozzle plate will be extremely limited.

(19) The air relay *C* consists of two convex disks separated by a leather reinforced metallic diaphragm. The two convex portions are held together with screws allowing the leather diaphragm to be suspended between them. On the top of the air relay are two air screens and, at the bottom, the suction nipples which lead into the evacuated area of the control boxes. Figure 90 shows the three air relays and

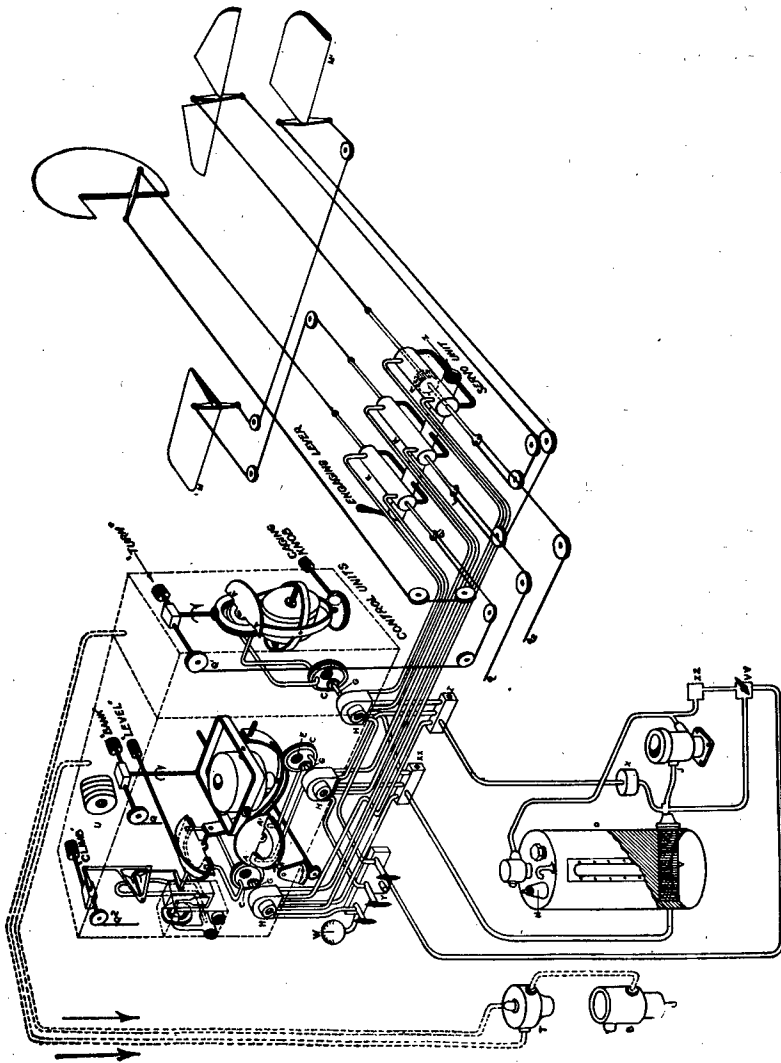

FIGURE 90.—Complete automatic pilot in neutral position.

their location in the mounting frame. The leather diaphragm is very sensitive and a vacuum of approximately 0.4 inch of mercury will be sufficient to cause the diaphragm to deflect from an equilibrium position to an extended position, moving with it the balanced oil valve.

(20) The follow-up cables Q are connecting units for coordination between the air pick-off system and the hydraulic system. There is one cable for each control. The follow-up clutch R is a cork-lined clutch automatically making contact with the clutch plate when the control units are in the mount assembly and the follow-up clutch spring S is used to keep the cable tight and to take up slack when moved away from the winding.

143. Operation.—*a.* The hydraulic oil and vacuum pumps, being engine-driven, start the operation of the automatic pilot immediately after the engine is started. Oil pressure is built up in the system and a partial vacuum is created in the areas as shown in figure 91. This figure shows the method of lateral control only, that is, of the ailerons.

b. The operation of the automatic pilot is dependent upon the fundamental principle of the gyroscope, rigidity. Because of this property, it is possible to establish a fixed reference in space. The gyro mechanism as used in the automatic pilot consists essentially of small air-driven rotors so mounted as to have 3° of freedom of rotation. The spinning axis of the rotor in the directional gyro control unit is always in a horizontal plane and in the bank and climb gyro control unit in a vertical plane. The rotor is pivoted in a gimbal ring, this inner ring is likewise pivoted in a vertical ring, and it in turn is pivoted in the case proper. Due to this type of rotor suspension, the rotor sets up a force which is transferred to the vertical ring, causing the entire assembly to remain rigidly in position regardless of any outside torque imposed upon it. The gyro then maintains a fixed position and allows all associated units to move about it.

c. When the air nozzle and air nozzle plate edge are exactly in balance (fig. 92 ①), each air port or opening in the air nozzle is open and cutting the edge of the air nozzle plate by the same amount. While this condition exists, the same amount of air will escape from each air nozzle port, A and A' . Since the air nozzle plate is part of the vertical ring and is immovable, then any change of attitude in flight, such as a cross wind in the case of the rudder control, would cause the airplane to leave its course. The result of the action would affect the air pick-off system and cause it to become unbalanced and appear as in figure 92 ②. This occurs because the spinning rotor retains its position in space holding the nozzle plates rigidly and allowing the air nozzle to rotate about it. This demonstrates that the pressure in lines 3 and 4 are not equal because the pressure in line 3 is restricted as the air nozzle A has

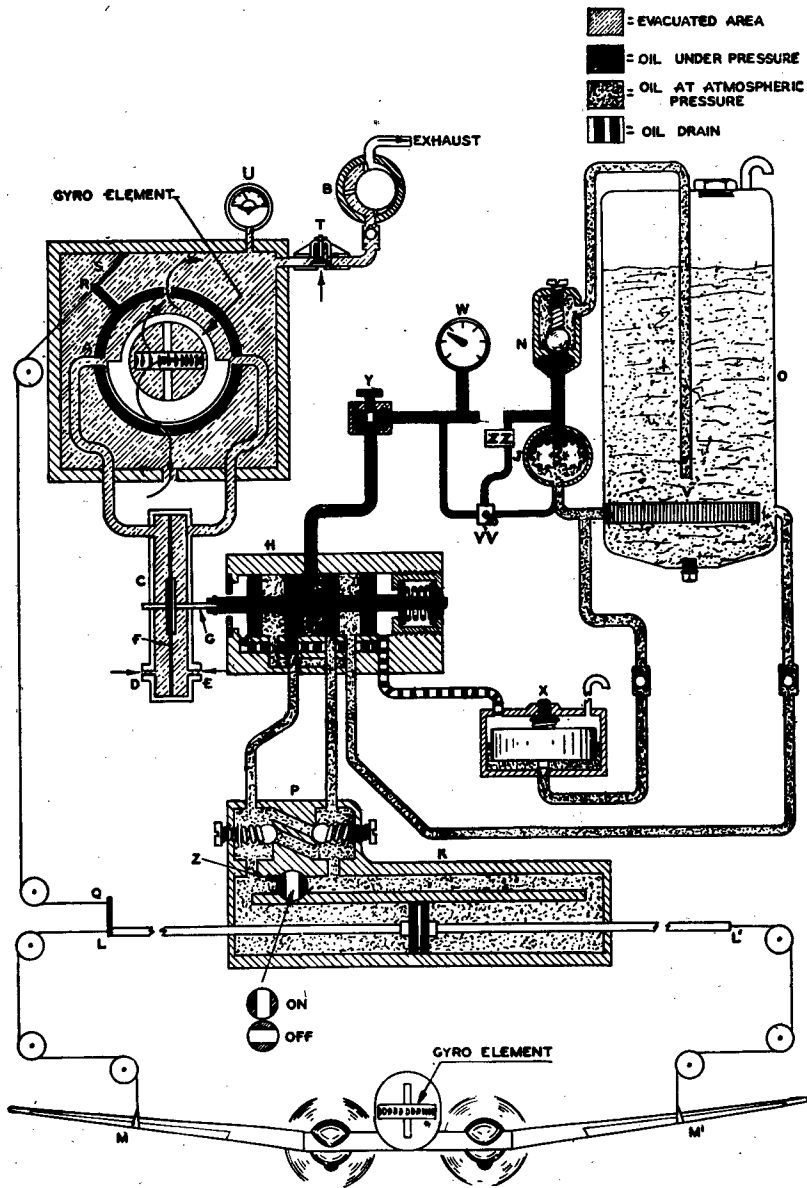

FIGURE 91.—Diagram of automatic pilot showing lateral control only.

assumed a position over the nozzle plate. Any difference of pressure at the nozzles immediately causes deflection of the diaphragm in the air relay. This movement of the air relay causes movement of the piston in the balanced oil valve as can be seen in figure 91. Any movement of the oil valve unbalances the pressure on the two ports leading to the

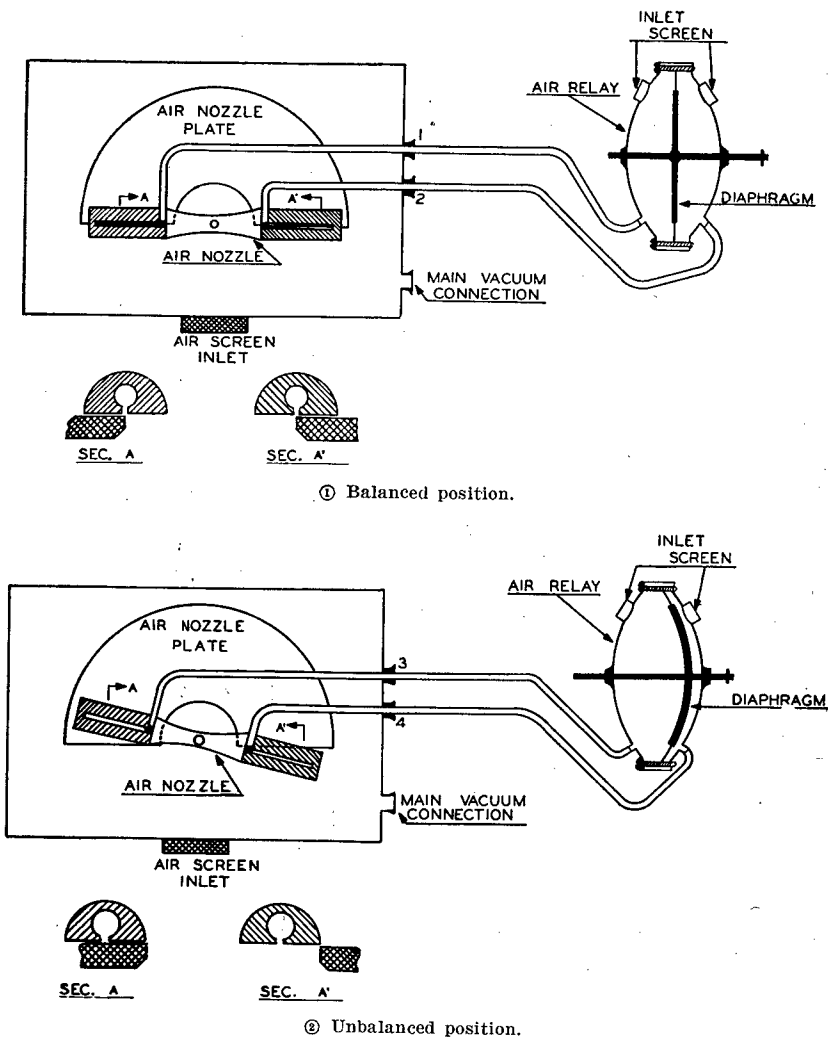

FIGURE 92.—Operation diagrams of air relay and air nozzle.

servo cylinder. Unequaled pressure in opposite ends of the servo cylinder will cause the piston to move. The piston being a continuous part of the control cable will cause the control surface on the airplane to change attitude. This change in position of the airplane control surface will cause the airplane to resume straight and level flight.

d. In controlling an airplane, it is not only necessary to apply control to bring the craft back to level flight when it has been disturbed, but also to begin to remove the applied control as the craft is returned to level so that the control surface will be back to neutral when the

change of attitude has been fully corrected. Over control and the return to neutral is accomplished by the follow-up system. One end of the follow-up cable is attached to the servo piston and the other is wound around the follow-up pulley. Figure 93 shows the follow-up

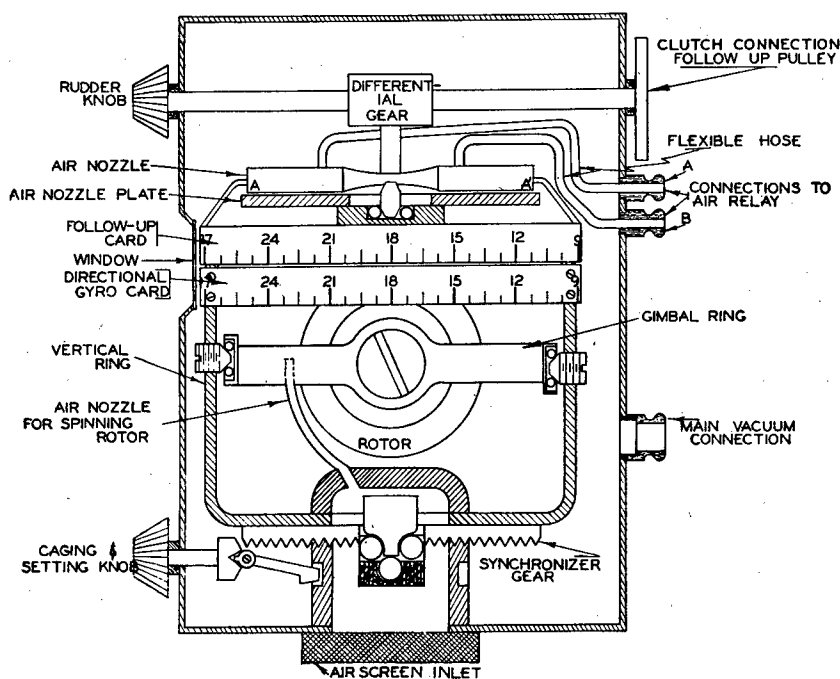

FIGURE 93.—Diagram of air pick-off arrangement, follow-up pulley clutch, and differential gear box.

pulley clutch and a differential gear box and shows that any movement of the follow-up clutch will be taken up in the differential gear box and cause the air nozzle to turn above the air nozzle plate. The air pick-off system is then in an unbalanced condition and as the pressure changes in the control box it also changes in the air nozzle ports. However, in *A* the air flow is restricted. The restriction of the air is immediately taken up by the deflection of the diaphragm in the air relay and the air relay causes the balanced oil valve to move. This displacement causes application of pressure in the line leading to the servo piston. The servo piston and follow-up cable, being integral, move simultaneously. The follow-up cable winds on the pulley, which in turn turns the shaft in the differential gear box and rotates the air nozzle. When the air nozzle becomes neutral with the plate, the entire system is balanced and all control correction ceases.

144. Installation.—All automatic pilot control units are tested before leaving the factory or the Air Corps repair depots and are ready for service when received. Initial installations of the automatic pilot are made at the airplane factories and repair depots. Removal or replacement of major units should be accomplished in the service by qualified instrument personnel only.

145. Maintenance.—*a.* The general points on maintenance given in section II are applicable to this instrument and its component units.

b. The following method of procedure and order of execution will be followed on each preflight inspection by the airplane crew chief:

(1) Check oil level in sump (should be from one-half to three-fourths full).

(2) Start engines.

(3) Check emergency oil bypass for "open." Normally this valve will always be open, but should always be checked and set to the full open position.

(4) Uncage gyros.

(5) Check level flight knob for "off."

(6) Check suction. This should not be less than 3 inches Hg. or more than 5 inches Hg., 4 inches being desired.

(7) Close speed control valves. Turn knobs on these valves clockwise until the scale reads zero.

(8) Check oil pressure. As the pressure varies on different airplanes, the normal reading for this measurement must be obtained from the handbook on the airplane.

(9) Open speed control valves. Match cards on directional gyro and a line follow-up indices on bank and climb control.

(10) Engage pilot.

(11) Check for air in the hydraulic system. Press on each control in each direction. If instant resistance can be felt, that part of the hydraulic system is free of air. If the control moves easily and the resistance builds up as the control is pressed and if there is a sudden kick-back when the control is released, it is a positive indication that there is air in the system which must be removed before the airplane takes off, inasmuch as it is not possible to accomplish the removal of air after the airplane is in flight. To insure successful operation of the automatic pilot it is absolutely essential that the air be worked out of all three of the control systems in the following manner:

(*a*) Open speed control valves wide. Each numeral represents one turn of the knob or displacement of the valve seat 0.025 inch.

(*b*) Turn on oil and vacuum.

(*c*) Centralize all controls (approximately).

(*d*) Line up indices, rudder, aileron, and elevator.

AIRCRAFT INSTRUMENTS

- (e) Engage pilot with engaging lever.
- (f) Turn all control knobs hard over to extreme limits until indices remain separated.
- (g) Disengage pilot and hold controls in this hard-over position for 15 seconds.
- (h) Reengage pilot and repeat operations (f) and (g) in the opposite direction.
- (i) Recheck for air in the hydraulic system.
- (12) After it is certain that all air has been removed from the system, reengage the pilot and operate each control knob in a slight amount. In each case, check the movement of the rudder, the ailerons, and the elevator for the proper movement as their respective control knobs are turned.
- c. All screens are checked for excessive accumulation of dirt and removed and cleaned at the required intervals.
- d. Oil is added to the sump as required and whenever this operation is performed only "oil, lubricating, aircraft, hydraulic mechanism, specification 3580—for Sperry Automatic Pilot" is used.

SECTION XXXI

MISCELLANEOUS INSTRUMENTS

	Paragraph
Aircraft clocks.....	146
Driftmeters.....	147
Accelerometers.....	148

146. Aircraft clocks.—*a.* Timepieces with various features are required for use on aircraft for general flight and navigation purposes. All standard instrument panels are equipped with one 8-day clock. These clocks have, in addition to the usual chronometer mechanisms, a sweep second hand. They are designed to operate on shock-proof panels and are mounted in the same manner as all other aircraft instruments. Some types have "elapsed time," "time out," and "stop" features incorporated in their design as shown in figure 94.

b. The ordinary maintenance of clocks consists of winding, setting, checking for accuracy, and regulation.

(1) In winding, no greater force should be used than is actually required. The clock is fully wound when the winding stem offers a slight resistance to further winding and any attempt to wind beyond this point will result in damage to the delicate mechanism.

(2) In checking for accuracy, the second hand is checked against the second hand of another clock or watch of known accuracy for a

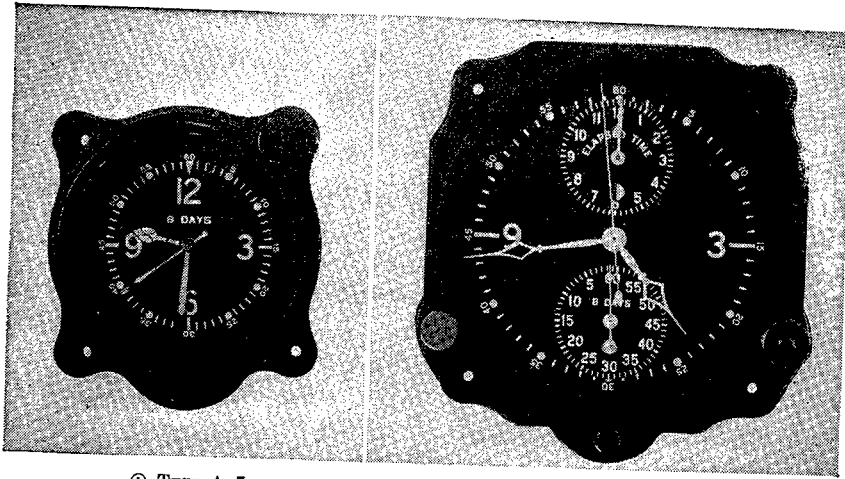

⊙ Type A-7.

⊙ Type A-8.

FIGURE 94.—Aircraft clocks.

period of not less than 1 hour. When the rate of gain or loss is excessive the clock is replaced.

(3) Regulation of the clock is a base function. If regulation in conformance with the tolerance specified for the particular clock cannot be accomplished, the clock is sent to the depot for repair.

c. Pocket and wrist time and stop watches are also required for use in working various navigation problems. An example of each is given in figure 95.

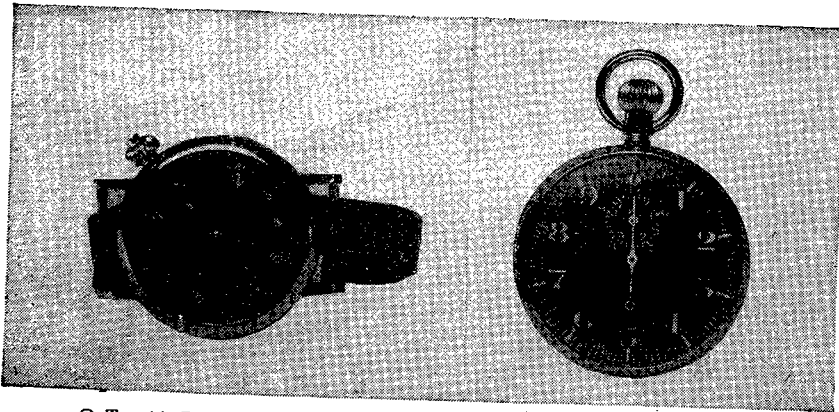

⊙ Type A-7 time and stop watch.

⊙ Type A-8 stop watch.

FIGURE 95.—Navigation watches.

147. Driftmeters.—*a.* The purpose of driftmeters is to determine and measure the amount of drift when flying cross wind courses. Some additional uses of this instrument are to—

- (1) Determine relative bearings.
- (2) Measure ground speed by timing.
- (3) Aid in compass compensation and swinging in the air.
- (4) Aid in air speed indicator calibration.

b. Several standard types have been developed for use on the different types of tactical airplanes.

(1) The driftmeter (fig. 96) is of the optical periscopic type and is installed on the side wall of the aircraft with the objective end pro-

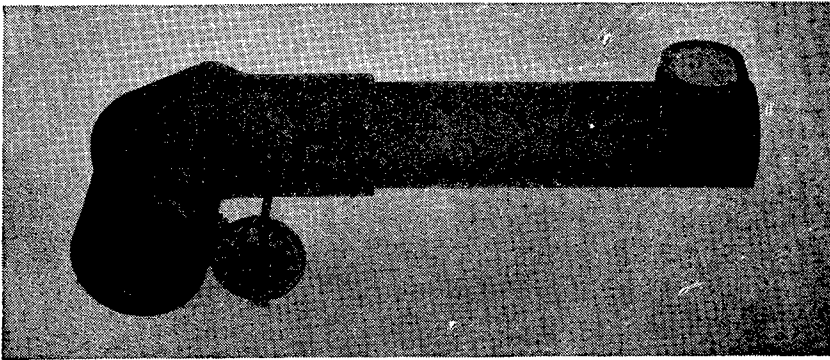

FIGURE 96.—Type D-1A driftmeter.

truding through the fuselage. The instrument has a field of view of 25° with the ground image one-third natural size and completely erect; that is, right side up and in correct right and left relationship. Accurately in the plane of the image is the reticle, rotated by means of the control dial adjacent to the eyelens. Angle of rotation of the reticle is read on the control dial or on the edge of the reticle itself. The eye distance is 500 mm (approximately 20 inches). With the eye at this distance from the eyelens, the full field is visible but the position of the eye is not critical. Due to the large eye distance, the instrument may be installed on or below the instrument board and may therefore be used by the pilot.

(2) The driftmeter (fig. 97) is a telescopic type of instrument of variable length with a trail sighting feature, variable magnification, illuminated recticle, and bearing scale. Eyepieces giving unit power and three-power magnification are furnished, the unused eyepiece being carried in the socket under the drift scale. The meters are supplied assembled in the minimum length of 3 feet over all and in some instances with extension tubes 2-, 3-, and 5-foot lengths.

(3) The driftmeter (fig. 98) is of the straight tube periscopic type incorporating a gyro stabilized reticle, variable magnification, a trail sighting feature, and provision for use as a bearing plate for terrestrial objects. The length overall may be any value from 3 feet 9 inches to 8 feet without effect on the optical characteristics. The instrument is mounted vertically in the airplane with the eyepiece convenient to the navigator and the objective end projecting below the airplane sufficiently to clear the fuselage. With his eye to the eyepiece, the observer sees images of the ground directly below projected on the reference lines of the reticle, or by operating a handle, shifts the line of sight up to 85° from the vertical. The entire assembly is rotated on

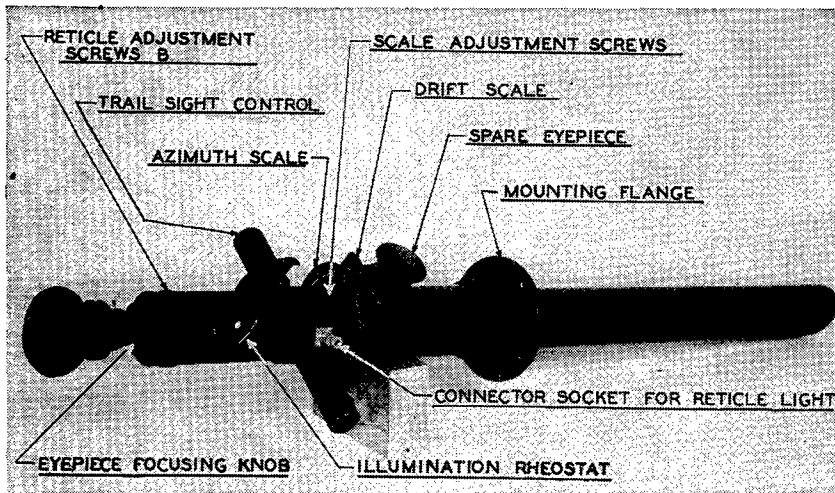

FIGURE 97.—Type B-2 driftmeter.

a bearing in the mounting flange for drift or relative bearing measurements. Pitch or roll of the airplane has only slight influence on drift measurements due to the stabilization of the reticle. The field of view is 25°; the magnifications are unity or 3-power. The reticle is illuminated for night use.

c. In the maintenance of driftmeters, the external surfaces of the objective and eyepiece lens are checked to insure that these surfaces are free of dust, dirt, oil, and finger marks. If dirty, first blow the surfaces with a light pressure blower or with the mouth. A light film of moisture will usually be noticeable. While the lens is damp, any soft tissue paper free of gritty materials is wiped gently across the surface. In order to avoid scratching of the lens, a fresh piece of the paper must be used for each wiping motion. If the lens is extremely oily, it will be permissible to moisten the tissue paper with a

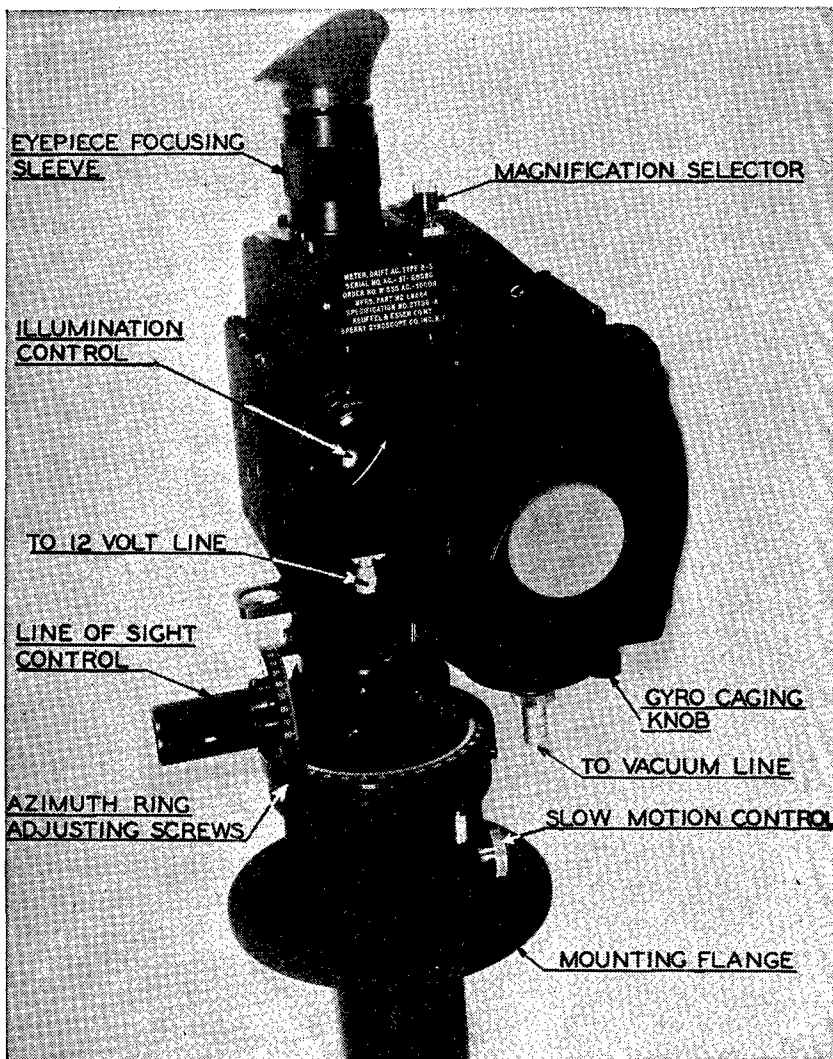

FIGURE 98.—Type B-3 driftmeter.

little carbon tetrachloride followed immediately by wiping with clean tissue. Never remove the lens or attempt to clean the internal parts of the driftmeter, as damage to the reference wires is certain to result. In order to check rapidly the adjustment of the vernier and the reference wires of driftmeters, the verniers are set to their zero indices and a light is held directly over the observer's lens (eyepiece). By looking through the driftmeter in the reverse direction, the reference wires are seen as rather large lines which should be parallel to the

longitudinal axis of the airplane. Adjustment is made by loosening the set screw and shifting the vernier.

148. Accelerometers.—*a.* Indicating accelerometers are used by pilots to check the forces imposed on the aircraft structure while flying. The use of the accelerometer enables the pilot to become familiar with the acceleration characteristics of different aircraft so that permissible values as given on the operating V-g diagrams will not be exceeded.

b. The indicating accelerometer (fig. 99) consists of a weight carried on an arm that swings through a limited angle parallel to the

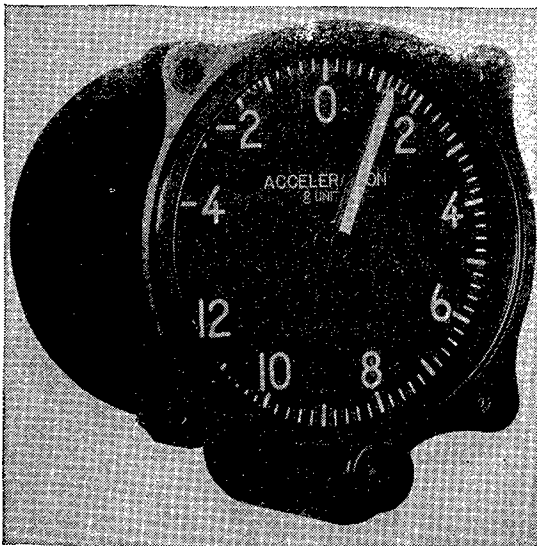

FIGURE 99.—Indicating accelerometer.

plane of the dial. Its motion is restrained by two springs which serve as a means of calibration. The angular motion of the axis is transmitted to the indicating hand which carries with it the maximum and minimum reading hands. The maximum and minimum hands remain at the highest positive and negative points reached in acceleration until reset to +1 g by a slight rotation of the setting knob. These hands will be reset after each maneuver. The dial is marked to indicate acceleration in gravitational units of a climb, dive, or turn.

SECTION XXXII

TYPE C-1 PORTABLE INSTRUMENT FIELD TEST SET

Paragraph

General	149
Purpose and use	150
Description	151
Operation	152
Application	153
Inspection and maintenance	154

149. General.—*a.* Maintenance testing of aircraft instruments may be divided into two distinct classes: field tests and bench tests. Field tests refer to those performed without removal of the instrument from the aircraft. Bench tests refer to those wherein the instrument is removed from the aircraft and tested elsewhere.

b. Apparatus used for testing aircraft instruments consists of two types: C and A. Type C equipment is portable and used for line maintenance and to some extent for base functions; type A is stationary or shop equipment and is used for base maintenance. Type C-1 field test set and the application thereof are discussed in this section.

c. Only properly trained and authorized personnel are permitted to use test equipment for the reason that such equipment (as well as the instrument being tested) is delicate, expensive, and easily damaged with improper use.

150. Purpose and use.—*a.* Type C-1 test set is a portable, lightweight, compact unit mounted on a three-wheel chassis to permit it to be moved conveniently to a place adjacent to aircraft in the hangar or in the field. The unit (fig. 100) may be transported by aircraft or truck to a remote location for field operation; the test set should be towed only by hand.

b. The test set consists of various master indicators, gages, and devices to actuate instruments to be tested, and provides a means of performing a majority of inspections and tests without removal of instruments from the instrument panel. Thus by connecting the instruments to the various operating devices and the respective master indicators or gages, comparative readings may be taken and the accuracy of the instruments determined within suitable limits. The test set is used to perform scale error tests, friction error tests, and tests to insure correct and accurate operation of instruments during flight.

151. Description.—*a. General.*—The test set consists of fixed units and others which are considered auxiliary equipment. The auxiliary equipment may be removed from the test set and carried

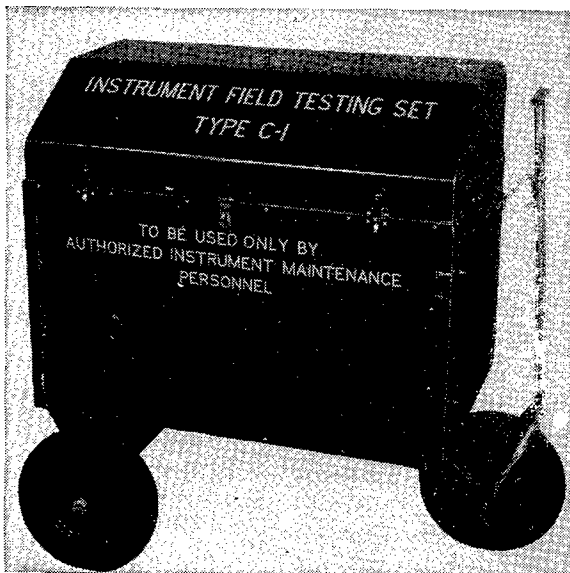

FIGURE 100.—Type C-1 portable instrument field test set.

into the aircraft. The control panel of the test set is shown in figure 101. The location of the fixed units may be observed by reference to figures 102 and 103.

b. Control panel.—The control panel serves as a mounting base for eight control knobs, three master instruments, and a master thermometer. The control knobs are numbered and marked in accordance with their respective purposes. All reference to control knobs in operating instructions herein will be made by number. The panel is installed in an inclined position for convenient operation of control knobs and reduction of parallax error when reading the master instruments and thermometer. The master instruments consist of a type C chronometric tachometer, a type D air speed indicator, and a differential pressure gage. The tachometer and the air speed indicator have standard scales and graduations. The differential pressure gage has a full scale range of 10 inches of mercury, or approximately 5 pounds per square inch. During vacuum or pressure tests, the air speed pointer will move simultaneously with that of the pressure gage as they are attached to a common connection. The direct reading master thermometer is graduated in degrees centigrade.

c. Power unit.—This unit consists of an a-c and a d-c motor built integrally. It is located in and attached to the floor panel of the chassis. A reel with 100 feet of extension wire is attached to the floor panel for connection to remote electrical outlet. A fuse is installed

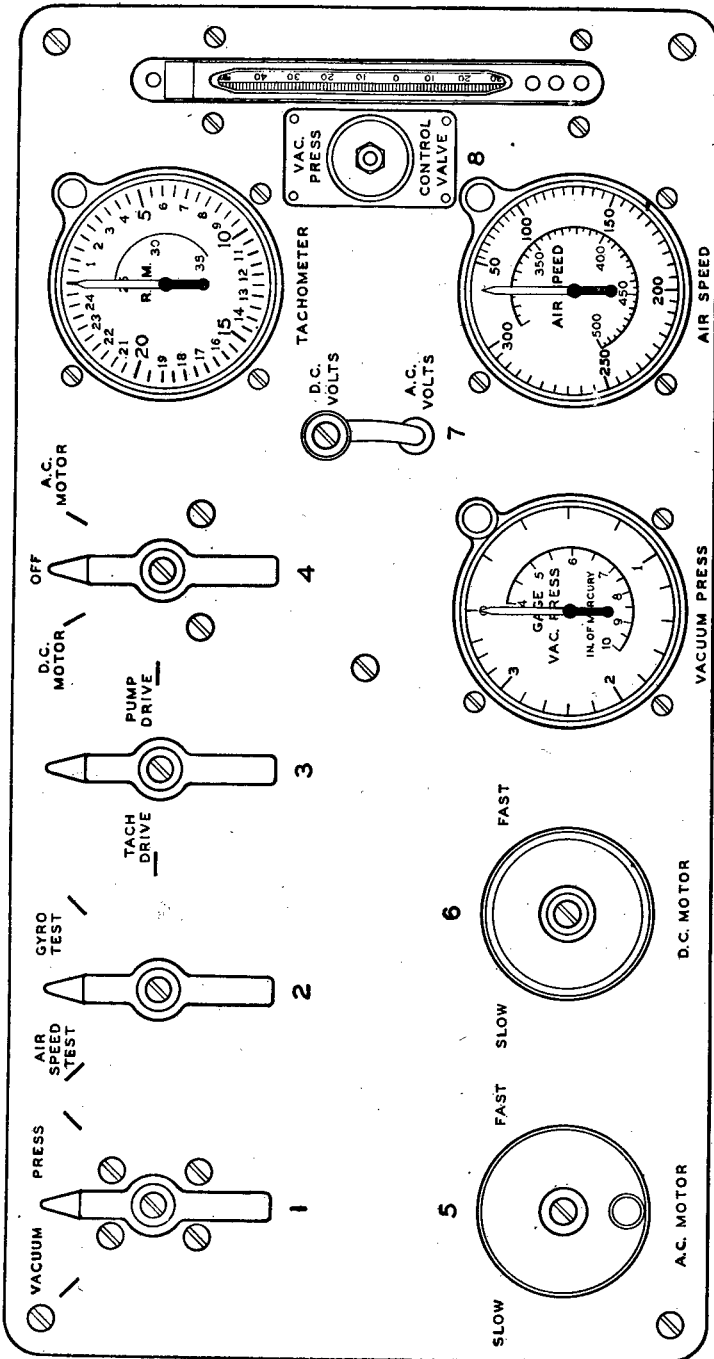

FIGURE 101.—Type C-1 test set control panel.

in each circuit to prevent damage to the power unit in the event of overloading. The fuses are of the plug type and are accessible through a door in the rear panel. Control knob (5) operates a ring

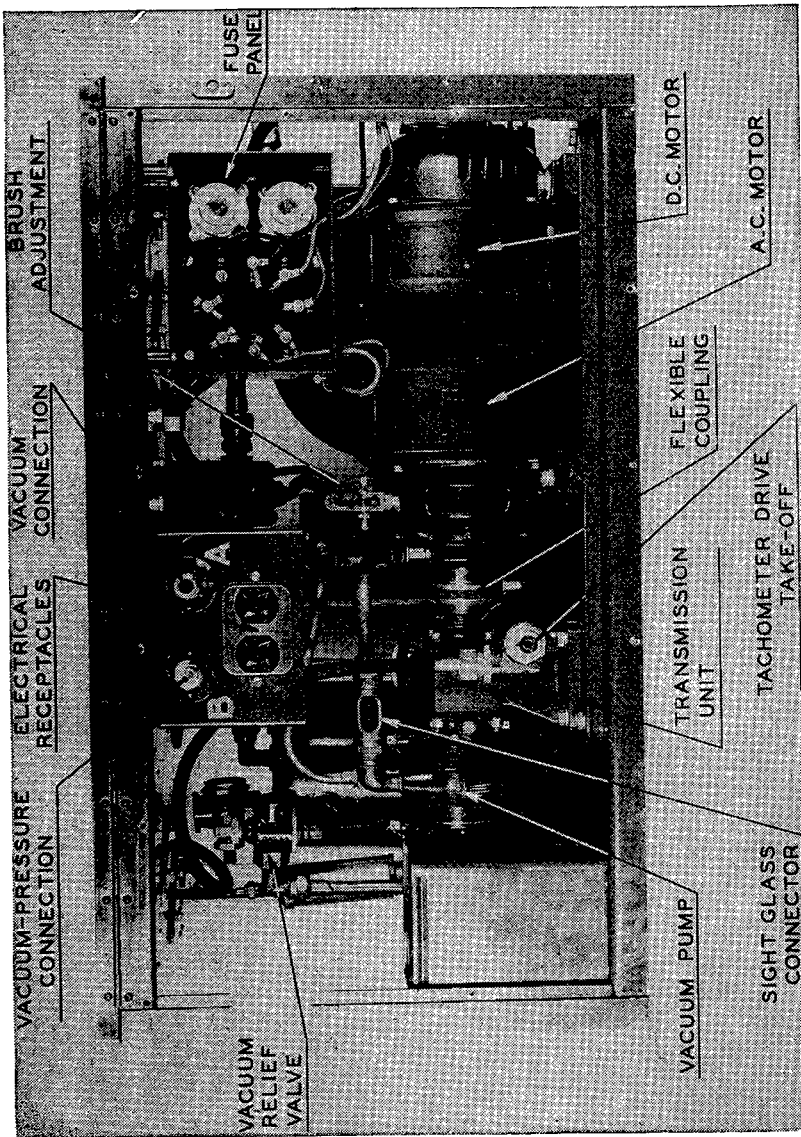

Figure 102.—Type C-1 test set, rear panel removed.

type brush holder which holds four carbon composition brushes on the commutator. This knob controls the speed of the a-c motor. The control mechanism consists of a screw thread attachment to a cable

which in turn is led through the tubing to the a-c motor. The brush adjustment to which the cable is attached embodies a joint designed to insure flexibility of movement. The speed of the d-c motor is controlled by knob (6) which is connected to a rheostat by means of linkage. The rheostat is located on the under side of the top panel. The

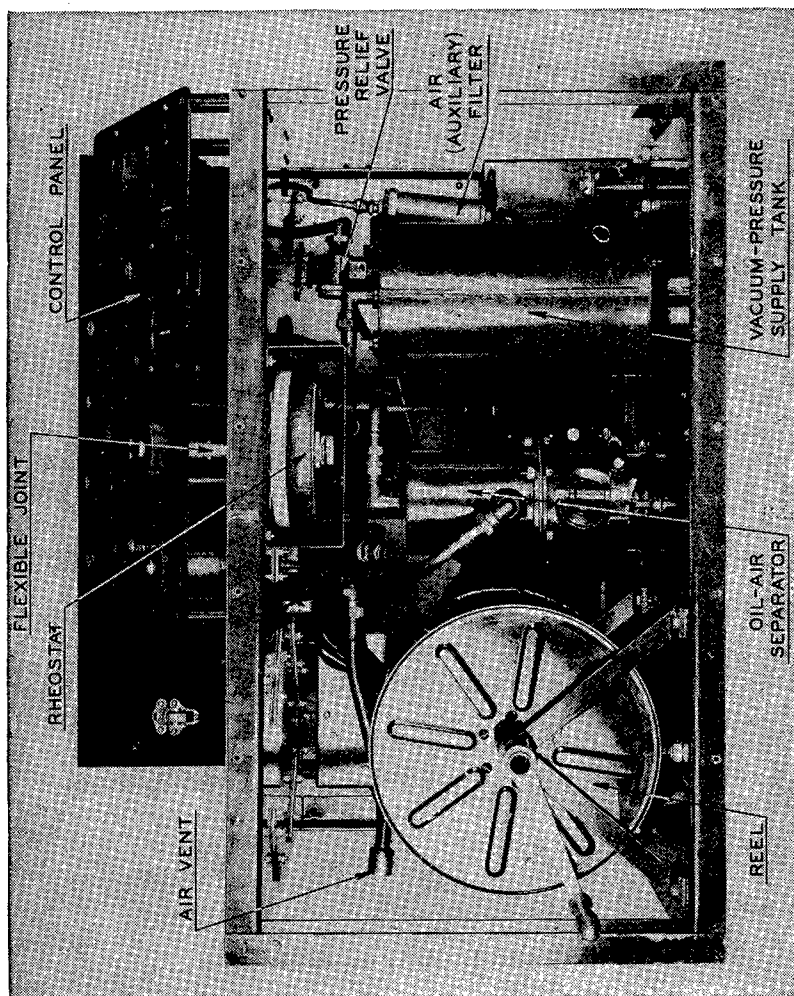

FIGURE 103.—Type C-1 test set, front panel removed.

power unit is connected to the bevel gear assembly of a transmission unit by means of a shaft equipped with a flexible coupling. The transmission unit is provided with take-offs for driving the air-vacuum pump and the tachometer drive. A special clutch, remotely controlled by knob (3), engages either the air-vacuum pump or the tachometer drive to the transmission, but only one of the units may be driven at

one time. Before changing the position of control knob (3), it is necessary to stop the power unit.

d. Air-vacuum unit.—(1) This unit consists of a standard airplane vacuum pump connected to a tank. Both the inlet and outlet ports of the pump are connected to a combination oil-air separator, through which the selector valve, operated by control knob (1), connects the pump to a vacuum-pressure supply tank. Therefore, the position of control knob (1) determines whether vacuum or pressure will be obtained, but not both at the same time. Pressure and vacuum relief valves are connected to the supply tank and are adjustable to the maximum output of the pump. A schematic diagram of the vacuum and pressure systems is shown in figure 104. Tube outlets, $\frac{1}{4}$ inch and $\frac{3}{8}$ inch in size, used respectively for the pressure and vacuum connections, are accessible through a door located in the rear panel of the test set. The $\frac{3}{8}$ -inch outlet (A) is used when connection is made to gyro instruments; suction is obtained by setting control knobs (1) and (2) to their correct positions. The $\frac{1}{4}$ -inch outlet (B) is used for testing air speed pitot static tubes, fuel pressure gages, manifold pressure gages, or suction gages. Pressure or vacuum may be obtained by correct setting of knobs (1) and (2). A filter is located adjacent to the supply tank in the line leading to the pressure-vacuum ($\frac{1}{4}$ -inch) outlet. A needle type valve is located in the same line and affords a means of delicate adjustment of pressure or vacuum; the valve is operated by means of control knob (8).

(2) A combination, two-compartment oil supply and oil-air separator is installed between the vacuum pump and supply tank. A line connects the oil supply tank or lower compartment with the inlet port of the vacuum pump, and the outlet port of the pump is connected to the oil-air separator or top compartment of the unit. Oil is drawn into the pump as a means of lubrication and as a seal for efficient operation. A sight glass connector is inserted in the line connecting the oil supply tank to the inlet port of the pump. This sight glass serves to indicate the quantity of oil vapor entering the vacuum pump during operation. Oil is expelled from the pump through the outlet port into the separator unit. The separator unit contains a series of baffles whereby a quantity of oil is removed and returned to the oil supply compartment. The remainder of the oil and exhaust air goes into the supply tank or is bypassed overboard through a screened vent. Under normal operation when the pump is receiving proper lubrication, a slight amount of oil vapor is exhausted through the vent to the atmosphere.

e. Electrical outlets.—Two standard, 110-volt outlets for two-prong plugs are mounted on the same panel with the pressure and vacuum

connections. These electrical outlets provide current for miscellaneous equipment such as extension light, electric soldering iron, etc.

f. *Master pressure gage unit (hydraulic).*—This unit (fig. 105) consists of a cylinder equipped with a manually operated piston for obtaining desired pressure. An oil reservoir, which is located on the top of the cylinder, is connected through a control valve to the inside of the cylinder. A flexible rubber connection is also made to the control valve and is used for attachment to the gage under test. The master gage is connected to the right side of the cylinder and is scaled with unit graduations of 1 pound per square inch and has a scale range

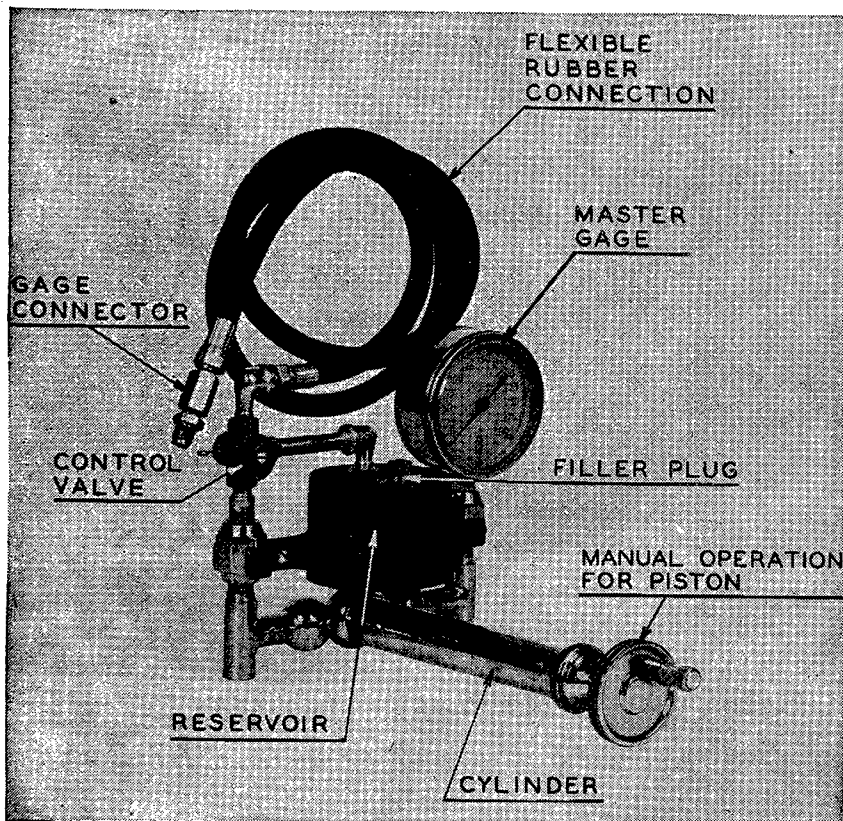

FIGURE 105.—Master pressure gage unit.

of from 0 to 300 pounds per square inch. This unit has wide application in performing tests. In addition to testing an engine oil pressure gage, it may be used for testing a fuel pressure gage, an automatic pilot oil pressure gage, and to a limited extent the landing gear pressure gage. Instructions for performing pressure gage tests are outlined in paragraph 153.

g. Master altimeter unit.—This unit (fig. 106) consists of a standard Air Corps type C sensitive altimeter mounted in a carrying case. A ratchet is installed in the panel of the case for manually vibrating the altimeter to remove any friction error which may be present. A calibration correction card showing the accurate calibration of the unit is placed in a holder inside the top cover of the carrying case. The entire assembly may be removed from the test set and carried into the aircraft.

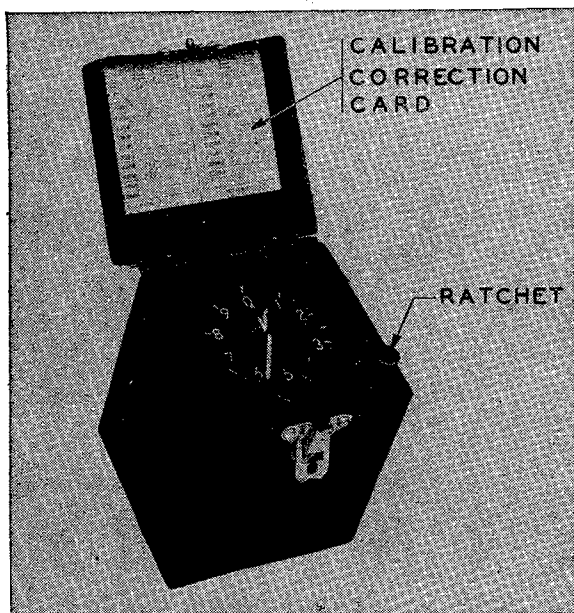

FIGURE 106.—Master altimeter unit.

h. Thermometer tester unit.—The thermometer tester unit (fig. 107) is designed for testing a cylinder temperature indicator. It consists of a millivoltmeter and two rheostats mounted on a panel in a hard-wood carrying case. The case is designed with a compartment in the top cover for accessories which include a direct reading master mercurial thermometer, a small screw driver, and a set of leads provided with alligator terminal grips for attachment of the test unit to the circuit of the aircraft thermocouple. The millivoltmeter is scaled in millivolts and degrees centigrade. It is manually controlled with the two rheostats, one being a combination master switch with adjustment for zero pointer position, and the other for selected scale range positions. A plunger type safety switch is installed in the panel and is controlled by the opening or closing of the top cover. In the event the

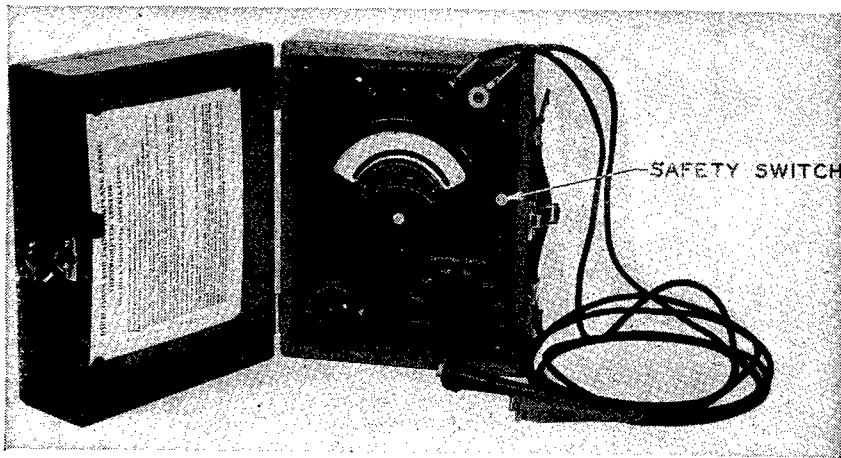

FIGURE 107.—Thermometer tester unit.

master switch is left in the "on" position, the current flow is automatically interrupted when the top cover is closed.

i. Electric continuity meter tester.—This unit (fig. 108) consists of a combination milliammeter, voltmeter, and ohmmeter mounted in a composition case. The instrument is equipped with receptors which are marked for scale and range values. Two toggle switches are provided to select either a-c or d-c volt, ohm, ampere, or milliampere

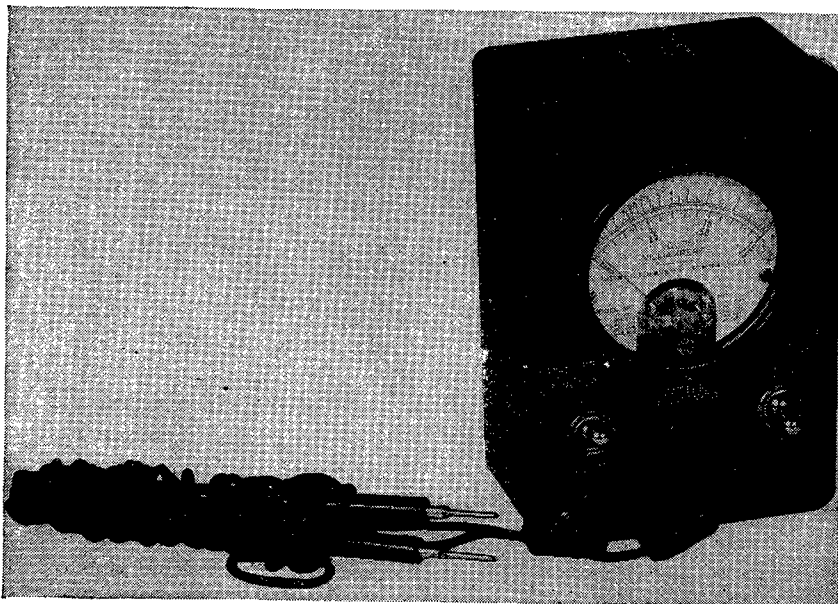
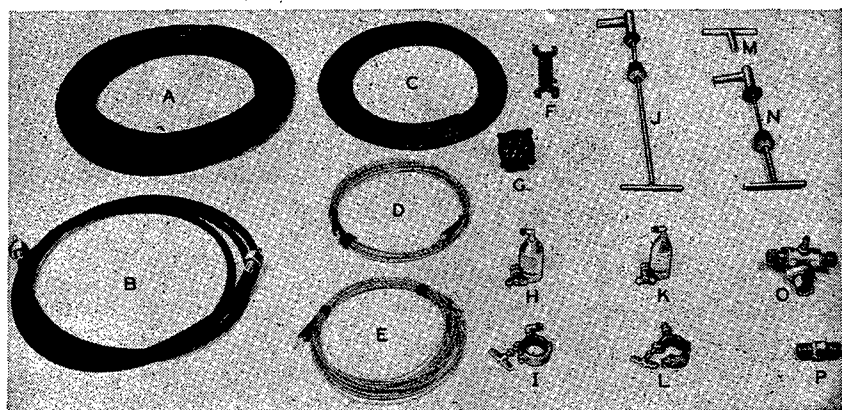

FIGURE 108.—Electric continuity meter tester.

scales. A set of leads complete with plugs and rods is furnished with the tester. The unit is used to test voltage and resistance in aircraft electric circuits.

j. Accessories and attachments.—In addition to the specified units described herein, the accessories and attachments shown in figure 109 are used with the type C-1 test set.



- | | |
|-------------------------------------|---------------------------------------|
| A and C. Flexible rubber tubing. | H and K. Pitot fixtures. |
| F. Combination open end wrench (2). | I and L. Static fixtures. |
| D and E. Test leads. | J and N. Venturi seals. |
| F. Combination open end wrench (2). | M. Hose connecting tee. |
| G. Suction gage. | O. Tachometer drive adapter, two-way. |
| | P. Tachometer drive adapter, 180. |

FIGURE 109.—Accessories and attachments, type C-1 test set.

152. Operation.—*a.* The test set is equipped to operate on 110 volts alternating or direct current. Recommended practice is to use alternating current when operating at permanent or base stations. When operating in the field where a source of alternating current is not available, type C-1 electric portable power plant unit should be used to supply direct current (see Air Corps Technical Order 19-30-2 for instructions), in which case it may be necessary to increase the voltage slightly above 110 volts to compensate for voltage drop through the line and to obtain sufficient motor speed for checking tachometer.

b. Before connecting the test set to the source of power, the following operations should be performed:

- (1) Set control knob (4) to the "off" position.
- (2) Set control knob (7) to the appropriate position, that is, either "d-c volts" or "a-c volts," depending upon the source of supply; control knob (4) can then be adjusted only to the source indicated by control knob (7).

(3) Set control valve (8) closed. This is a needle type valve and should not be tightened too firmly.

(4) Set control knob (5) or (6) (depending upon the source of supply) to "fast" position.

(5) If the vacuum-pressure system is to be used, set control knob (3) to "pump drive," otherwise set it to "tach drive." (The operator should never attempt to change the position of control knob (3) while the motor is operating.)

c. The current may be applied to the test set following the performance of the above-mentioned operations. As all instruments are designed to operate under vibration, at any time an instrument is tested without engine operation the panel should be lightly tapped to overcome friction and sticking of the pointer. Connections between the various operating units of the test set and the aircraft instruments should be made as close to the engine as possible. The tests should be conducted as outlined in paragraph 153.

153. Application.—*a. Testing tachometers.*—The scale error test may be performed on either the chronometric or electric tachometer. A scale error test is merely a check of simultaneous readings on the aircraft instrument against a master indicator.

(1) *Chronometric tachometer (shaft-driven type).*—(a) Disconnect the aircraft tachometer shaft at the engine and connect to the auxiliary flexible drive shaft which should be attached to the tachometer drive take-off in the rear of the test set as shown in figure 110. Avoid making any bends of less than 6-inch radius in the flexible shafts.

(b) Set control knob (3) to "tach drive" and knob (5) or (6) (depending on whether alternating current or direct current is used) to "fast" position; then set control knob (7) for the type of current to be used and control knob (4) to desired position. Adjust the motor speed so that the master tachometer reads even hundreds, starting at either slow or fast speed (the slow speed of the motor should not be below 500 rpm). Progress up or down the scale and compare readings of the airplane instrument with those on the master indicator. If the readings differ by more than the amount specified in the Air Corps Technical Order, the aircraft tachometer should be replaced.

(2) *Electric tachometer (generator-voltmeter type).*—Disconnect the tachometer generator from the drive on the engine and connect the flexible drive shaft from the test set to the drive end of the tachometer generator (fig. 111). Avoid making a bend of less than 6-inch radius in the flexible shaft. Operate the test set and note whether

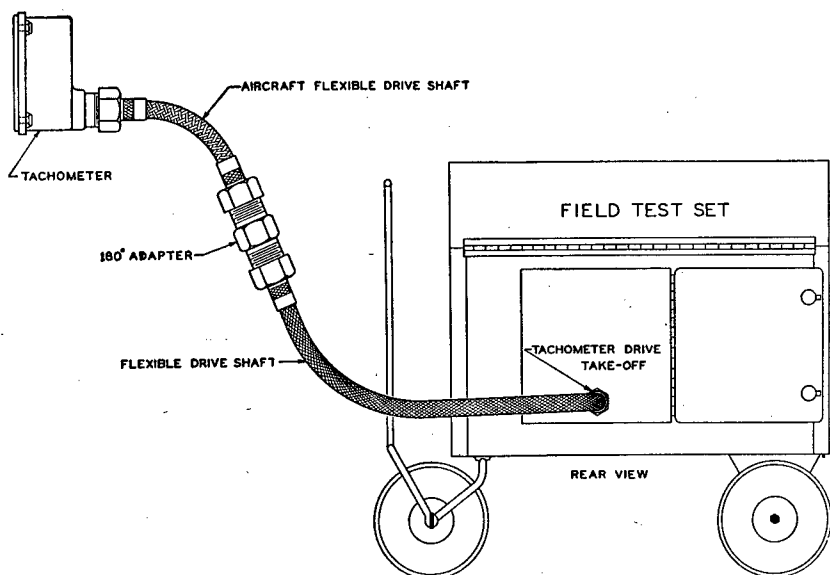
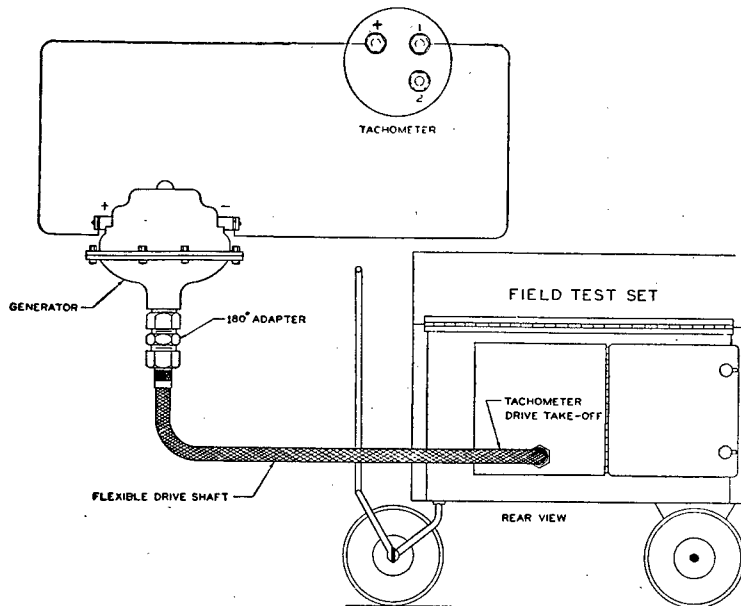

FIGURE 110.—Connection for chronometric tachometer (shaft-driven type) test.

the polarity of the generator is correct. If the polarity is reversed, disconnect and reverse the leads at the tachometer generator. After all connections are completed and correct polarity obtained, the test procedure is the same as outlined above for the chronometric (shaft-driven) tachometer. Make comparative readings of the master tachometer and the aircraft tachometer at each 100 rpm graduation. If the readings differ by more than the amount specified in the Air Corps Technical Order, the airplane tachometer generator and indicator should be replaced. Slight adjustments may be made by means of the "zero adjuster" on the tachometer indicator in the aircraft. Do not retard or advance the pointer by means of the adjuster more than one-half graduation.

(3) *Synchronization (tachometer generators).*—(a) Disconnect the two tachometer generators from the engines and attach them to the tachometer drive adapter (two-way) as shown in figure 112. With the use of test leads, connect the tachometer generators to the disconnected terminal leads at the engine.

(b) Set control knob (3) to "tach drive" and control knob (5) or (6) (depending on whether alternating current or direct current is used) to "fast" position; then set control knob (7) for the type of current to be used, and set control knob (4) to desired position. With the speed adjusted to 1,800 rpm (adjustment made by control knob



① Single tachometer indicator installation.

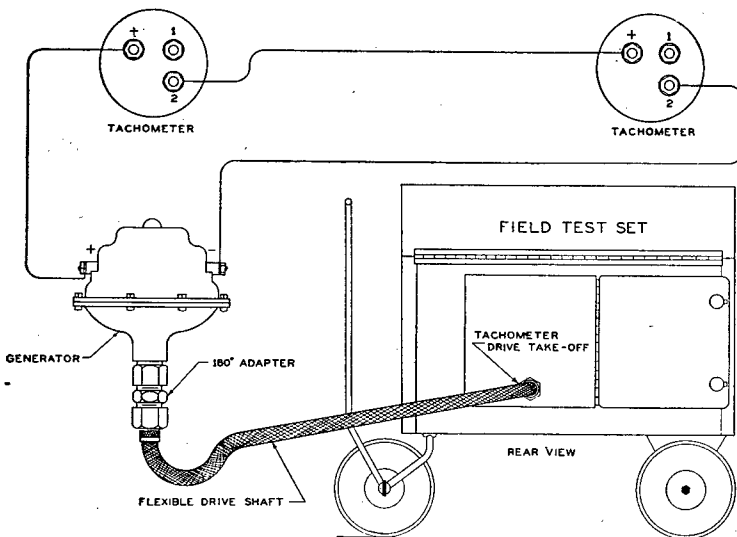

② Dual tachometer indicator installation.

FIGURE 111.—Connection for electric tachometer (generator-voltmeter type) test.

(5) and (6)) check the electric tachometers and engine synchronizer by using the switch in the aircraft. If the generators are not synchronized small adjustments may be performed, using a nonmagnetic screw driver.

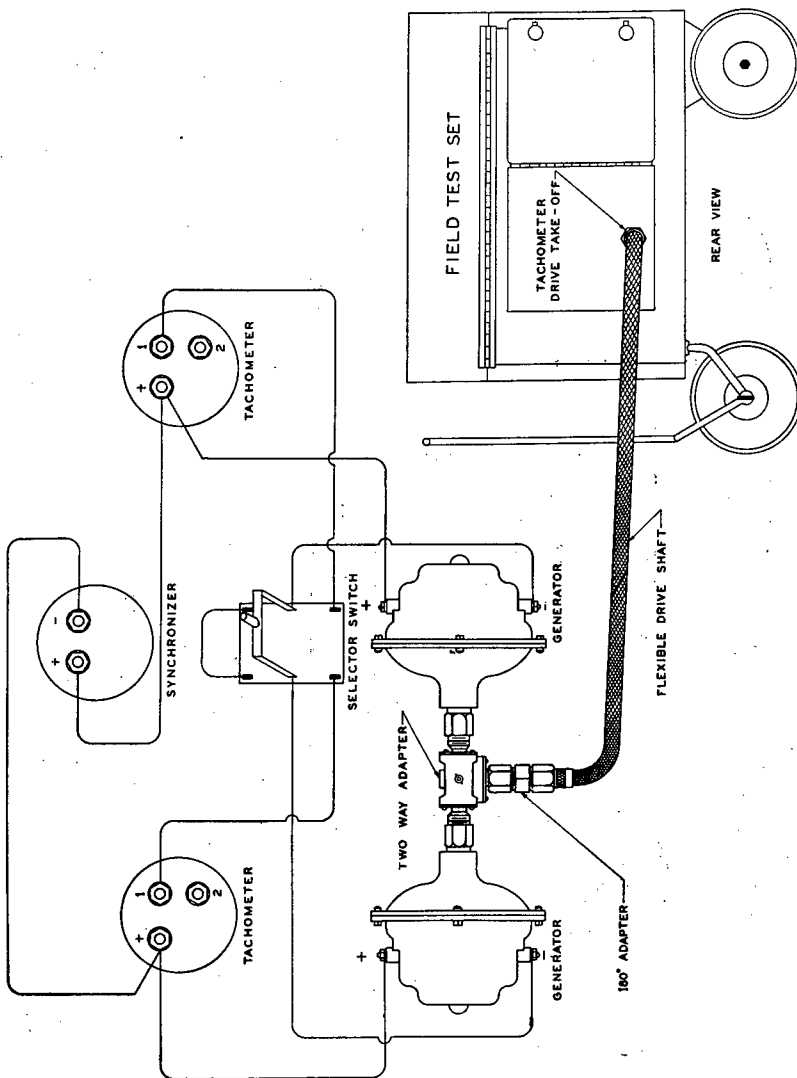

FIGURE 112.—Connection for synchronization of tachometer generators.

b. Tests requiring air pressure.—(1) The master differential pressure gage on the test set is used to indicate either suction or pressure. These tests are limited because of the pressure supply. The pressure

(approximately 5 pounds per square inch maximum) supplied by the test set unit is sufficient to test aircraft instruments through cruising and critical ranges. Tests are performed on the following instruments:

- (a) Fuel pressure gage.
- (b) Manifold pressure gage.
- (c) Air speed indicator.
- (d) Air speed tube (leak test, pitot line).

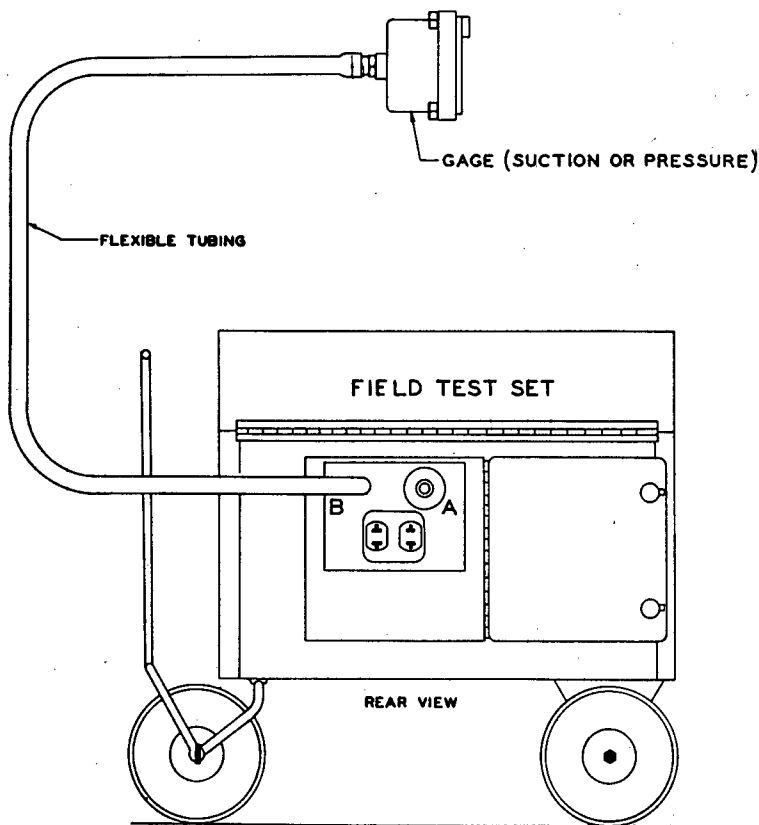

FIGURE 113.—Connection for suction or pressure gage test.

(2) Connect the smaller tubing to the $\frac{3}{4}$ -inch (B) outlet in the rear of the test set. Break the line connection of the instrument to be tested at the engine (fig. 113), or in case of air speed tube test use the pitot fixture as shown in figure 114.

(3) Set control knob (1) on "press" (pressure), knob (2) on "air speed test," knob (3) on "pump drive," and set control knob (8) closed. Next apply current to the motor (control knobs (4) and (7))

and adjust the pump speed with control knob (5) or (6). Slowly open control knob (8) and check the readings of the aircraft instrument with that of the master gage.

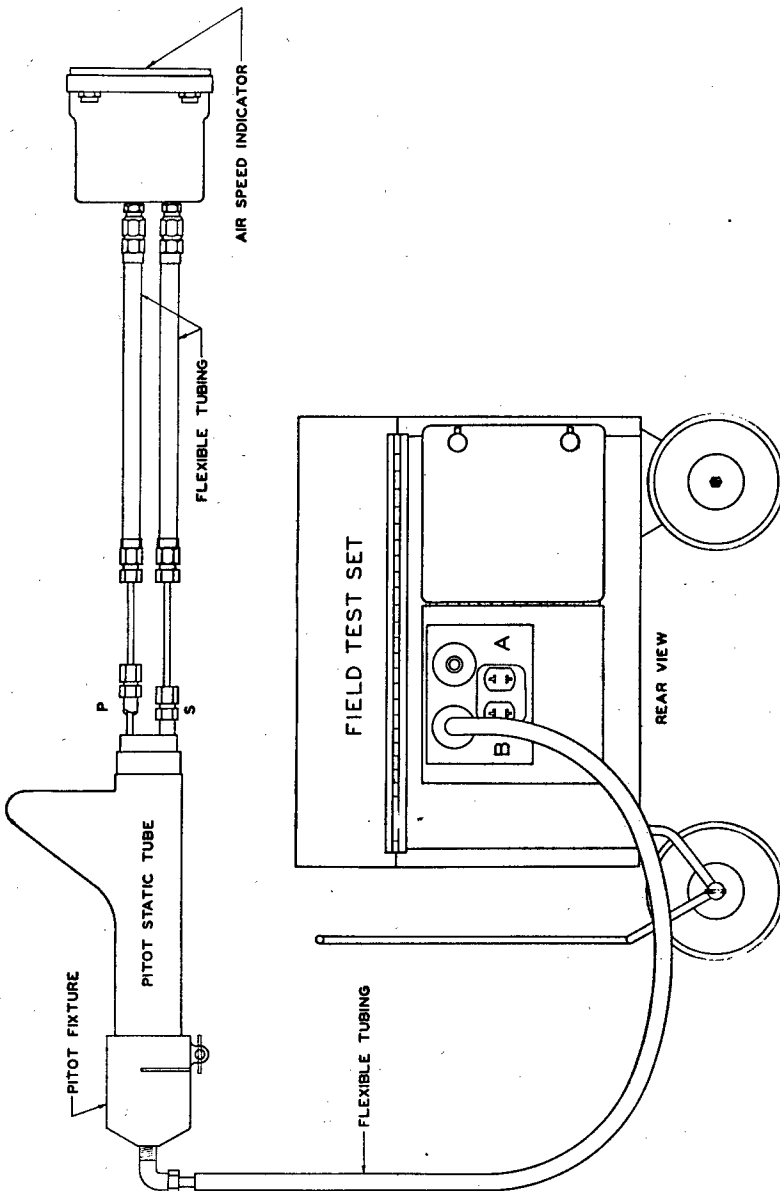

FIGURE 114.—Connection for air speed tube test (pitot fixture)

c. Tests requiring suction (except gyroscopic instruments).—(1) These tests are also limited because of the pump supply; the tests

include case leak and system tests. Tests are performed on the following instruments:

- (a) Manifold pressure gage.
- (b) Suction gage.
- (c) Air speed tube (leak test-static line).
- (d) Altimeter, rate of climb indicator, and air speed indicator.
- (e) Fuel pressure gage.

(2) Connect the smaller tubing to the $\frac{1}{4}$ -inch (B) outlet in the rear of the test set. Break the line connection of the instrument to be tested at the engine (fig. 113), or in case of air speed tube test use the static fixture as shown in figure 115.

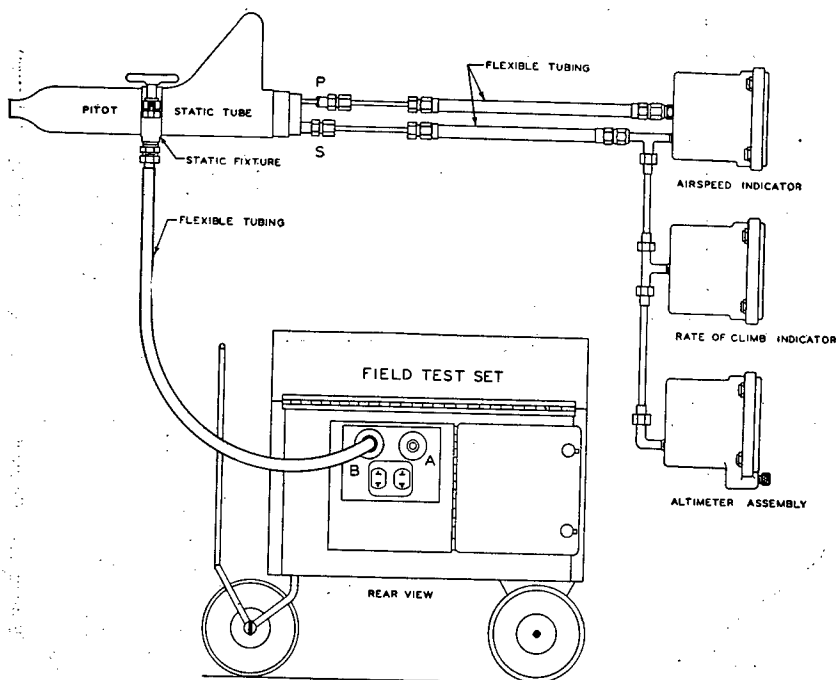

FIGURE 115.—Connection for air speed tube test (static fixture).

(3) Set control knob (1) on "vacuum," knob (2) on "air speed test," knob (3) on "pump drive," and set control knob (8) closed. Next apply current to the motor and adjust the speed with control knob (5) or (6). Slowly open control knob (8) and check the readings of the aircraft instrument with that of the master gage.

d. Testing gyroscopic instruments.—(1) Tests are performed on the bank and turn indicator, turn indicator (directional gyro), flight indicator, and gyroscopic type driftmeter, and include—

- (a) Dynamic.

- (b) Coast.
- (c) Cardinal.
- (d) Starting.
- (e) Alinement.

(2) Connect the larger tubing to the 3/8-inch (A) outlet in the rear of the test set. Break the vacuum line on the aircraft installation between the relief valve and the pump, if possible, and connect the

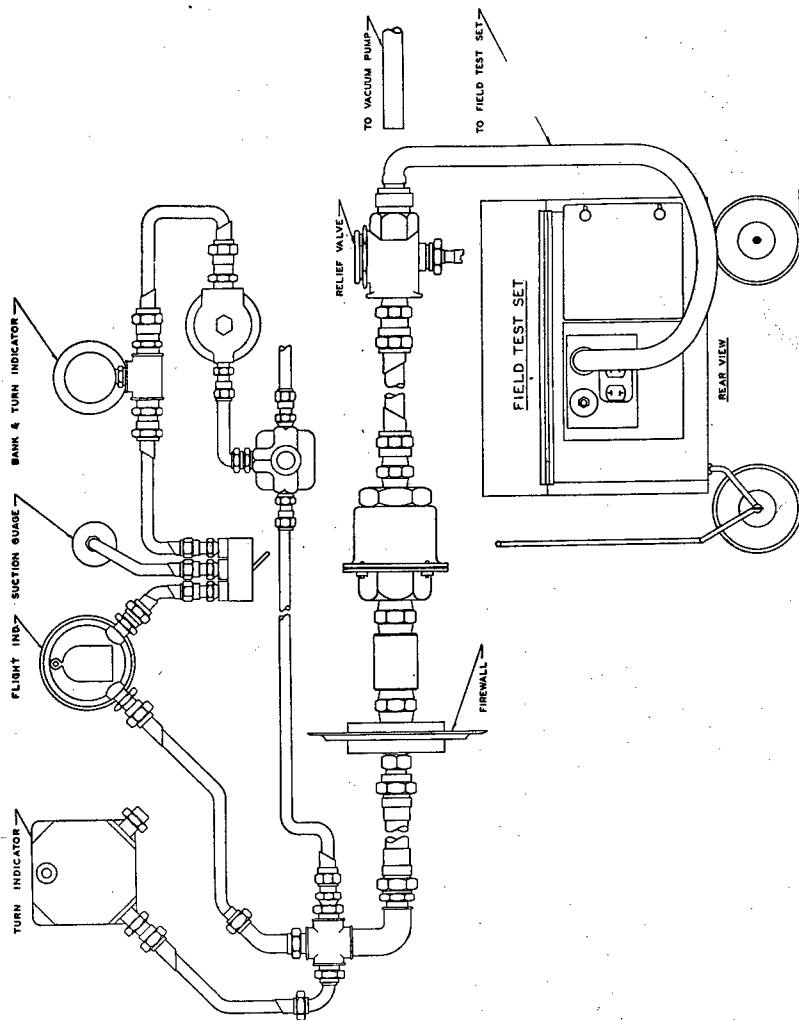

FIGURE 116.—Connection for testing gyroscopic instruments.

larger tubing from the test set to this line (fig. 116). If, however, the aircraft is equipped with a venturi tube, connect the tubing to the aircraft with venturi seals as shown in figure 117.

(3) Set control knob (1) on "vacuum," knob (2) on "gyro test," and knob (3) on "pump drive." Operate the motor on the set at a speed sufficient to obtain specified suction for the instruments as indicated by the suction gage in the aircraft. The procedures for the individual tests are outlined in Air Corps Technical Orders relevant thereto.

e. *Testing pressure gages (master pressure gage unit).*—Scale error tests may be performed on the fuel pressure gage, de-icer pressure gage, and oil pressure gage (engine and automatic pilot). The landing gear pressure gage may be checked for operation up to 300 pounds per square inch.

(1) Break the pressure gage line as close as possible to the engine and make connection between the tester line extension and the aircraft gage in the manner shown in figure 118.

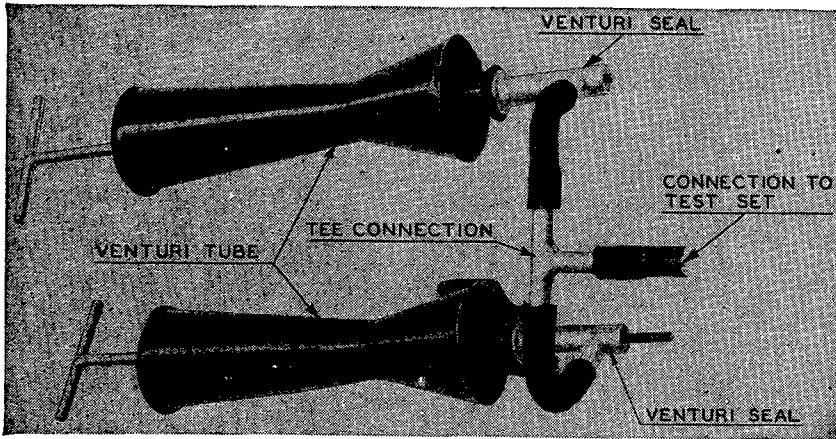

FIGURE 117.—Connection for venturi seals.

(2) With the piston all the way in, set the control valve on the tester to "reservoir" and screw the piston all the way out in order to fill the cylinder with oil. Then set the control valve to "line" and slowly turn the pressure screw, checking readings of the instrument against the master gage at a sufficient number of successive graduations. On excessively long lines it may be necessary to fill the cylinder from the reservoir several times before a sufficient supply of oil is present in the line to build up a working pressure. After the gage has been checked throughout its range and with the control valve remaining in "line" position, turn pressure screw all the way out, then set valve to "reservoir" and turn pressure screw all the way in. If additional oil has been used, precaution should be taken when draining the oil from the line back into the reservoir to permit all of the excess oil to run out through the filler plug in the reservoir.

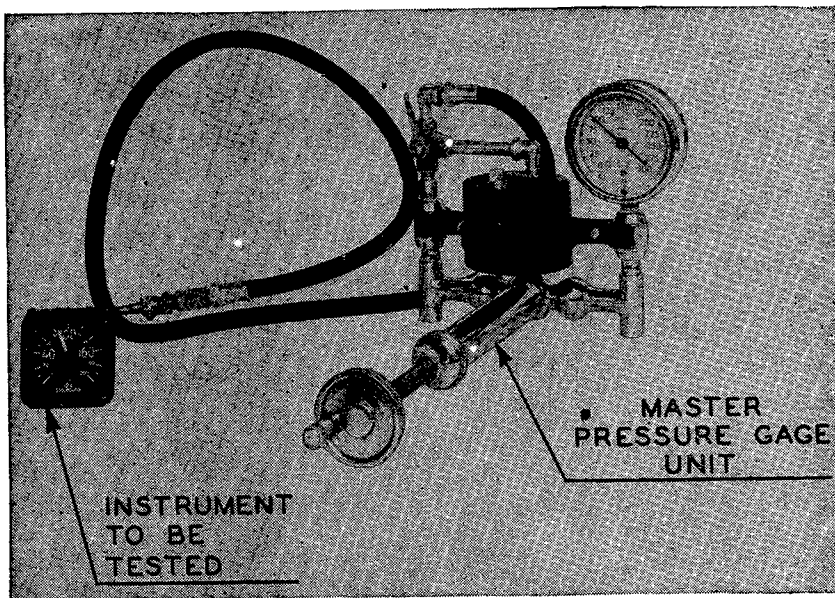

FIGURE 118.—Gage connection to master pressure gage unit.

f. Testing altimeters (for zero setting error).—Remove the master altimeter (fig. 106) from the test set and take it into the aircraft wherein the altimeter to be checked is installed. Both altimeters should be at approximately the same height. Set the reference markers on both altimeters to zero and compare the readings of the pointers. The two readings should correspond within the tolerance specified by the Air Corps Technical Order. If the difference is greater, the aircraft altimeter should be corrected as follows:

- (1) Set pointers on the aircraft altimeter to correspond with those of the master altimeter, making corrections from scale correction card.
- (2) Sufficiently loosen (do not remove) the small screw located to the left of the setting knob to permit the screw head to clear the case, and then pull it all the way to the left.
- (3) Pull out the setting knob and turn it until the reference markers read zero. Push the knob back into place, reset, and tighten the screw.
- (4) If a scale error test or any of the special tests are required to be performed, it is necessary to remove the altimeter from the aircraft and place it in a vacuum chamber. The master altimeter from the test set may be used as a standard for comparison if placed in the same vacuum chamber with the altimeter which is being tested. Corrections for the master altimeter should be made from the correction card located in the top of the case cover.

g. Testing cylinder temperature indicator (scale error test).—(1) Disconnect the positive thermocouple lead from the aircraft cylinder temperature indicator. Adjust the pointer by means of the zero

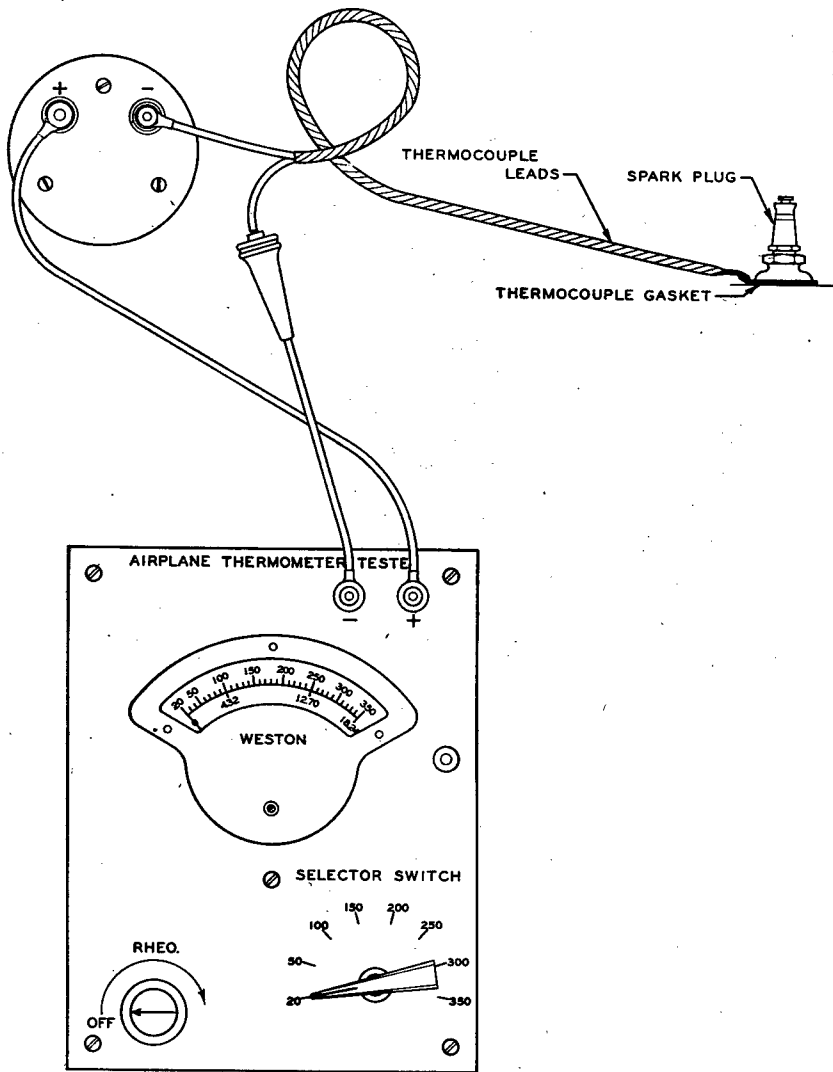

FIGURE 119.—Connection for testing cylinder temperature indicator.

adjusting screw to give an indication of 20° C. Lightly tap the indicator to prevent the pointer from sticking. As shown in figure 119, connect the positive (+) lead of the thermometer tester to the positive (+) terminal of the cylinder temperature indicator in the

air craft, and connect the negative (−) lead of the thermometer tester to the disconnected positive (+) thermocouple lead. The tester should be kept as nearly level as possible.

(2) With the battery switch in the "off" position, set or check zero of the thermometer tester at 20° C. mark. Then turn the battery switch of the thermometer tester to the "on" position and set the selector switch at 350° C. Adjust the rheostat until tester indicates 350° C. and after this has been accomplished do not change the rheostat adjustment. Next set the selector switch to 300° C., lightly tap the indicator to remove all friction error, and compare the readings of the tester and the aircraft cylinder temperature indicator. Repeat the above for increments of 50° C. The thermometer tester and the cylinder temperature indicator should agree within the tolerances as specified in the Air Corps Technical Order.

(3) After the tester is disconnected, set the aircraft indicator pointer to correspond with the reading on the portable glass thermometer furnished with the set, then connect the positive thermocouple lead with the indicator.

h. Lead resistance test.—As the reading of the cylinder temperature indicator is affected by a change in resistance of the leads, it is very important that the resistance remains constant. The leads should be checked at any time there is doubt concerning the accurate operation of this instrument on an aircraft installation. The thermometer tester is used for this purpose.

(1) With the battery switch in the "off" position on the thermometer tester, set or check the pointer at 20° C. mark. The flexible test lead clips should be free and not touch each other.

(2) Turn the battery switch to the "on" position, set the selector switch at 350° C., and adjust the rheostat until the meter reads 350° C. Precaution should be taken not to move the rheostat during the remainder of the test. Then carefully attach the flexible lead clips, one to each of the disconnected thermocouple leads (fig. 120), and note the reading on the thermometer tester. The indication should be within the limits as specified in the Air Corps Technical Order.

i. Testing voltage drop (pitot static tube heating element).—The electrical circuit of the pitot static tube is tested to determine whether the heating element is functioning properly and whether a sufficient source of supply is available at the head. The following procedure may be used to check the source of supply:

(1) Remove the inspection plate from the airfoil or fuselage of the aircraft at the rear of the pitot static boom to obtain access to the tube unions and electrical "snap on" connector.

(2) Set the volt-ohm milliammeter test unit (fig. 108) with the right-hand toggle switch to the "V-MA" (up) position and the left-hand toggle switch to the "DCV-MA" (down) position. Insert the

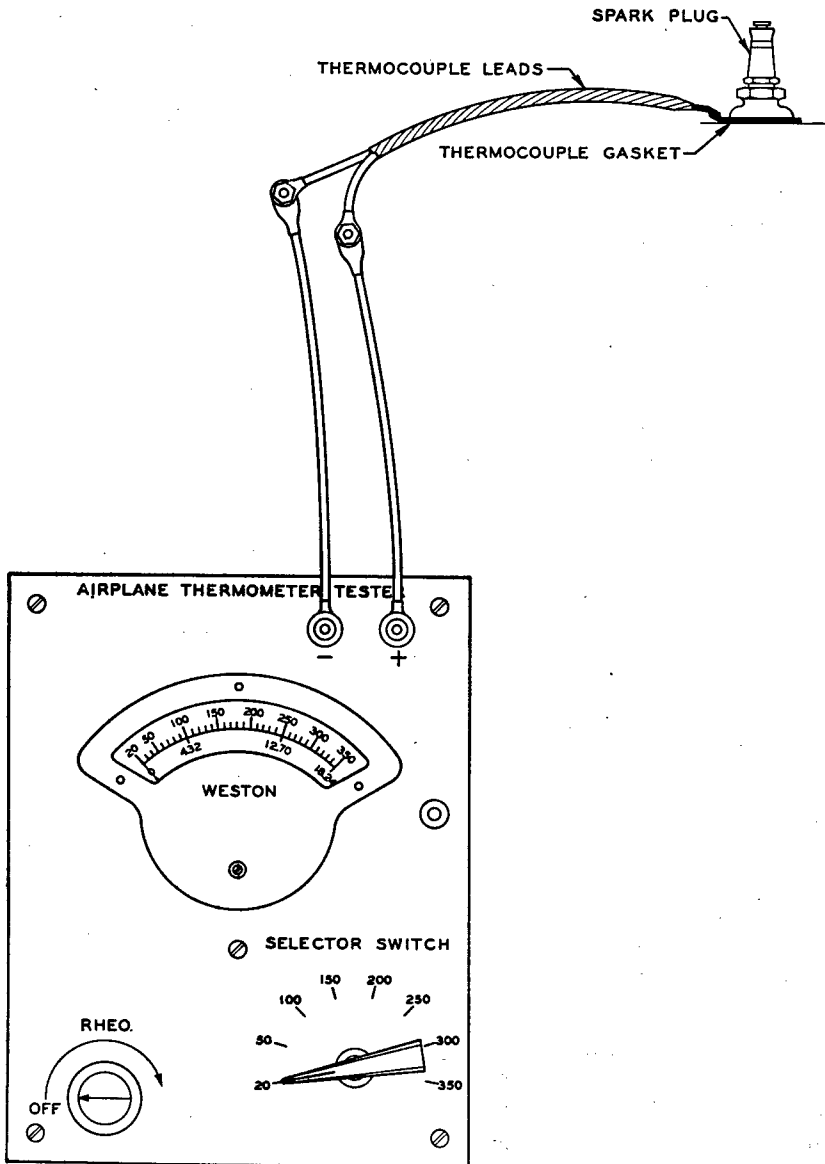

FIGURE 120.—Connection for thermocouple lead resistance test.

plug of one lead into the receptor marked "common" and the plug of the other lead into the receptor marked "15V." With the current

supplied to the pitot static tube, check the heating element for operation, and check the electrical circuit of the pitot static tube with the prods of the test instrument leads (fig. 121). The voltmeter readings should be within the tolerance as specified in the Air Corps Technical Order.

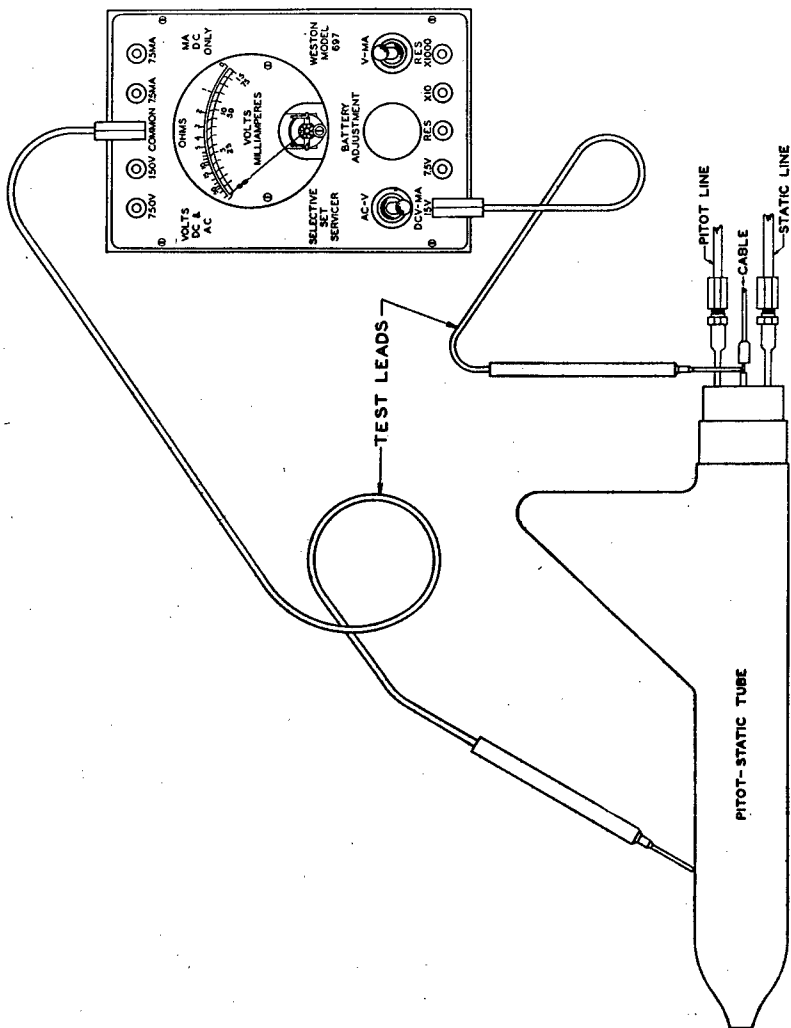

FIGURE 121.—Connection for voltage drop test.

154. Inspection and maintenance.—In order to insure efficient operation of the test set, various parts of the set should be regularly inspected and necessary maintenance performed as follows:

a. Weekly.—The tires should be checked and a pressure of 20 pounds per square inch maintained therein.

b. Monthly.—(1) *Motor.*—(a) The commutator should be cleaned and polished with a clean cloth. No oil or emery cloth should ever be used on the commutator. Roughness of the commutator may be removed by application of fine grade sandpaper.

(b) When brushes are to be replaced, a sheet of fine sandpaper should be folded around the commutator and the rotor revolved by hand in the correct direction until proper brush fit is obtained. Emery cloth should never be used to clean brushes.

(c) The motor bearings should be lubricated with specified soft cup grease.

(2) *Transmission unit.*—The transmission should be lubricated with specified oil.

(3) *Pressure-vacuum system.*—(a) The lines and valves of the pressure-vacuum system should be inspected for leaks. If valves are found which are difficult to operate, they should be lubricated with specified lubricating grease.

(b) To prevent any oil from reaching the instruments on the aircraft, the brass or bronze wool of the air filter should be removed and washed in gasoline to remove all trace of dirt and oil. The presence of oil vapor should be checked by placing the test set in operation for an air speed test and holding a sheet of clean white paper over the ¼-inch (B) outlet; any oil vapor present will immediately appear on the paper.

(4) *General.*—All bolts, screws, electrical connections, etc., should be checked for security; miscellaneous moving parts, such as reel assembly, motor and valve controls, etc., should be lubricated with specified light grade engine oil.

c. Yearly.—The wheel bearings should be repacked with specified aircraft grease.

d. Overhaul.—When maintenance becomes necessary which is beyond the scope of the organization or station personnel, the test set should be forwarded to a repair depot for general reconditioning. Minor maintenance of the test set such as replacement of the air-vacuum pump, master instruments, etc., may be accomplished by the activity concerned.

e. Master instruments.—Care should be observed to avoid subjecting the master instruments to misuse in order that their accuracy is not impaired. Calibration cards for each instrument should be kept for ready reference in the holder provided in the top of the test set. Master instruments should be checked frequently for accuracy by stations or depots. When necessary, additional master instruments together with calibration data should be requisitioned from depots.

f. Tachometer drive shaft.—Care should be exercised to avoid undue friction created in the tachometer drive shaft as a result of sharp bends or undue strain on the casing.

g. Air-vacuum pump lubrication.—The oil in the combination oil-air separator should be maintained at the proper level. The sight glass should be observed to note if pump is being lubricated. Specified oils should be used respectively for ranges of temperature from -45° to 0° C. and from 0° to 45° C.

h. Records.—A complete record should be kept on suitable inspection, lubrication, and maintenance form.

SECTION XXXIII

INSTRUMENT TEST EQUIPMENT

	Paragraph
General.....	155
Manometer.....	156
Vacuum chamber.....	157
Dead weight tester.....	158
Voltmeters.....	159
Ammeters.....	160
Ohmmeters.....	161
Thwing potentiometer.....	162
Decade box.....	163
Vapor pressure thermometer tester.....	164
Analysis cell test box (SAAD-E-70).....	165
Tachometer test stand.....	166
Turntable assembly.....	167
Gyroscopic instrument test fixture.....	168
Portable vacuum pump assembly.....	169
Portable oil pump assembly.....	170

155. General.—The scope of tests which may be performed with type C-1 test set is limited. Various types of test equipment are used for other tests which need to be performed on aircraft instruments and related units. This test equipment and methods of application are outlined below.

156. Manometer.—*a. Purpose and use.*—(1) The purpose of a manometer is to provide means for measuring pressures of gases and vapors. The manometer is used as a standard for calibrating and testing differential and absolute pressure instruments.

(2) The manifold pressure gage and the altimeter assembly are absolute pressure instruments which are tested with a manometer. The rate of climb indicator, air speed indicator, and the suction gage are differential pressure instruments which are tested with a manometer. When performing tests of the above-mentioned instruments,

it is necessary to provide a source of suction or pressure, and in some operations a vacuum chamber is essential. A detailed description of the vacuum chamber is given in paragraph 157*b*.

b. Description.—(1) Manometers may be classed as U-tube or straight tube types. In order to provide a large range of pressure with the manometer, various liquids are used including, among others, water (H₂O), kerosene, seal oil, and mercury (Hg.). The range of a manometer depends upon the over-all length of the tube and the specific gravity of the liquid. As the specific gravity of the liquid increases, the sensitivity of the instrument decreases. Therefore if small pressures are to be measured, it is desirable to use water or kerosene because of their lesser densities.

(2) The standard test manometer used in the Air Corps is a straight tube unit (fig. 122). It is equipped with a well which serves as a reservoir for the liquid. The liquid may be mercury, water, or kerosene. The well is constructed integrally with the tube or separately and connected to the tube. When a water manometer is used, an aniline dye (usually red) is placed in the water to facilitate quick and accurate reading of the column. The test manometer contains a multiple scale arrangement with a scale selector and zero adjustment knob. The various scales are shown in figure 123.

(3) Care must be exercised when reading a manometer as the shape or curvature (known as "meniscus") of the liquid level varies for water and mercury. Figure 124 shows the menisci for water and mercury and levels at which the readings are taken.

(4) When working with manometers it is advisable to remember some conversion factors commonly used:
29.92 inches Hg.=760 mm Hg.=34 feet H₂O=14.7 pounds per square inch.

c. Application.—(1) Inasmuch as the scale error test of an air speed indicator necessitates the use of a multiple scale manometer, this test will be used as an example. Many instruments may be tested and calibrated with the manometer. The Air Corps Technical Order for the particular instrument should be consulted for details.

(2) Figure 122 shows the connections for the manometer and the pressure supply; the panel of the vacuum chamber serves as a mounting base for the air speed indicator (connected to source of supply). The test is merely one of comparison, that is, the readings of the instrument under test are compared with those of the manometer. The air speed indicator is calibrated in accordance with the adiabatic formula which expresses the relationship between differential pressure and air speed. A table is used which is computed for air speed against inches of water or inches of mercury. Mercury is also used

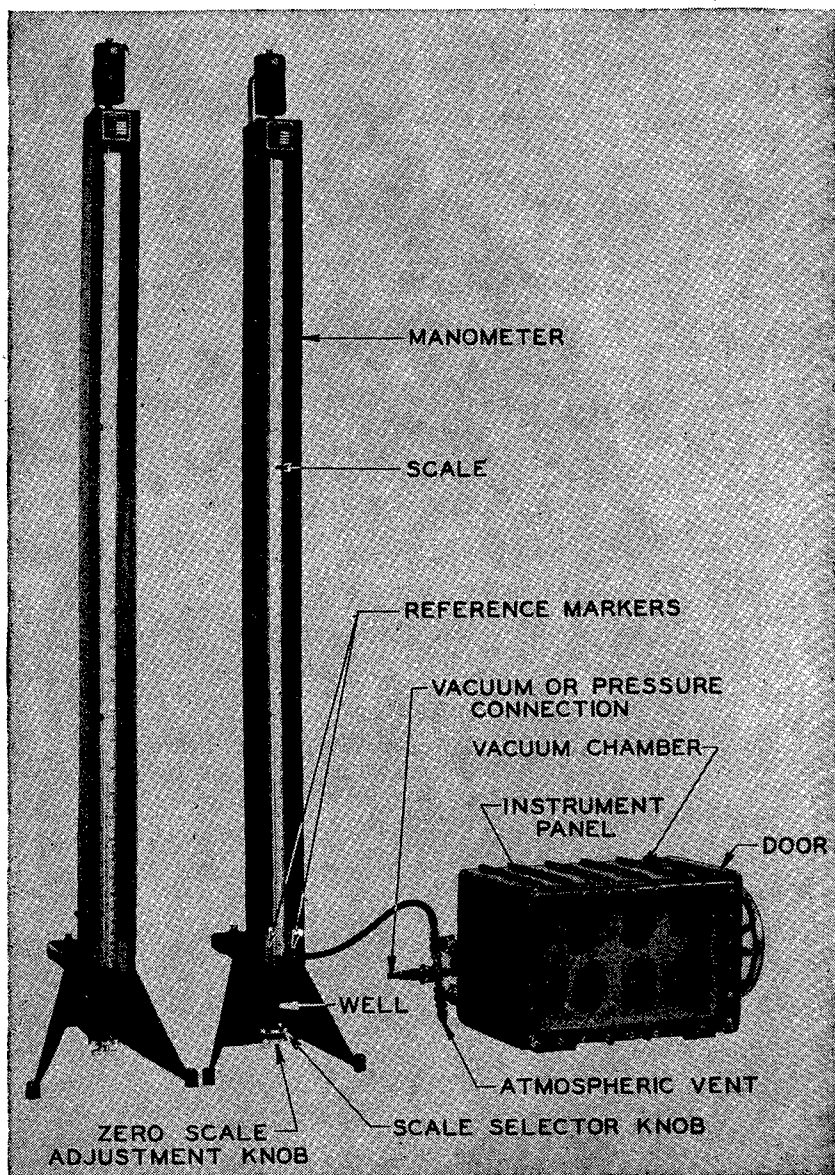
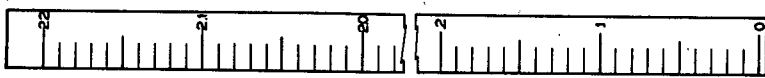

FIGURE 122.—Manometer and vacuum chamber.

in the test because of the required pressure in the higher range which under practical conditions could not be attained by using water. The air speed scale of the mercury manometer starts at 250 mph. To perform the test, progressive readings are obtained (by gradually

WATER SCALES



POUNDS AND HUNDREDTHS



KNOTS



MILES PER HOUR

MERCURY SCALES

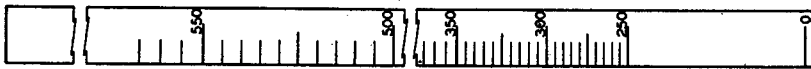

KNOTS



MILES PER HOUR



MILLIMETERS

FIGURE 123.—Manometer scales.

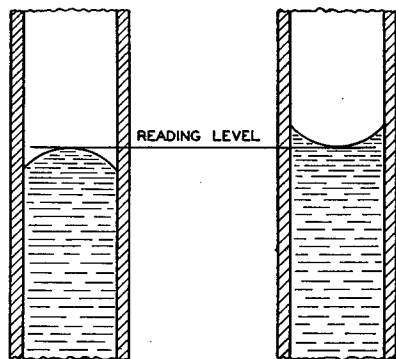

MERCURY (HG)

WATER (H₂O)

FIGURE 124.—Manometer reading levels.

increasing the pressure) and the errors in the indicator readings compared with the tolerances as specified in the Air Corps Technical Order. If the error exceeds the tolerance, the instrument should be sent to the depot for overhaul or recalibration.

d. Maintenance.—To provide accurate manometer readings, it is essential that the mercury and the tube are cleaned properly.

(1) *Cleaning mercury.*—(a) Mercury may be cleaned by stirring with a dilute solution of nitric acid (10 parts acid and 90 parts distilled water) or a solution of sulphuric acid (80 parts acid and 20 parts distilled water). After the mercury has been thoroughly washed and the acid solution removed by filtering, the mercury should be washed with distilled water, the water filtered off, and the mercury dried.

(b) The preferred method utilizes the arrangement shown in figure 125. The mercury is slowly poured into the funnel. The filter paper (pinholed) removes some of the impurities. The mercury sprays through the small funnel tip and passes through the acid solution. Other impurities are thus removed and the mercury collects in the bottom of the tube. When a sufficient amount of mercury accumulates, the pinch cock is opened and the clean mercury allowed to flow into the beaker. The flow of filtered mercury should be controlled carefully to prevent the flow of acid solution into the beaker; this may be accomplished by allowing a small portion of the mercury to remain in the bottom of the glass tube at all times. The mercury collected in the beaker is next passed through distilled water. If drying is essential, the beaker containing mercury is placed on asbestos over an open flame and heated (not above 110° C.) until all moisture is removed. Alcohol may also be used as a drying agent. If the mercury to be filtered has accumulated grease, it should first be passed through a 10-percent solution of potassium hydroxide and the above procedure followed, using nitric acid (10 percent).

(2) *Cleaning manometer tubes.*—Following prolonged periods of operation, the manometer tube often becomes clouded as a result of impurities deposited on the glass. To remove these impurities, a piece of medium stiff piano wire with a swab attached to one end is used. Select a material which will shed a minimum of lint during the swabbing process.

(a) Swab the tube with a strong soap solution to which a little ammonia has been added. Next swab the tube with a dilute solution of nitric acid (25 parts nitric acid and 75 parts distilled water). Place the tube against a white background and subject it to close

TM 1-413
156-157

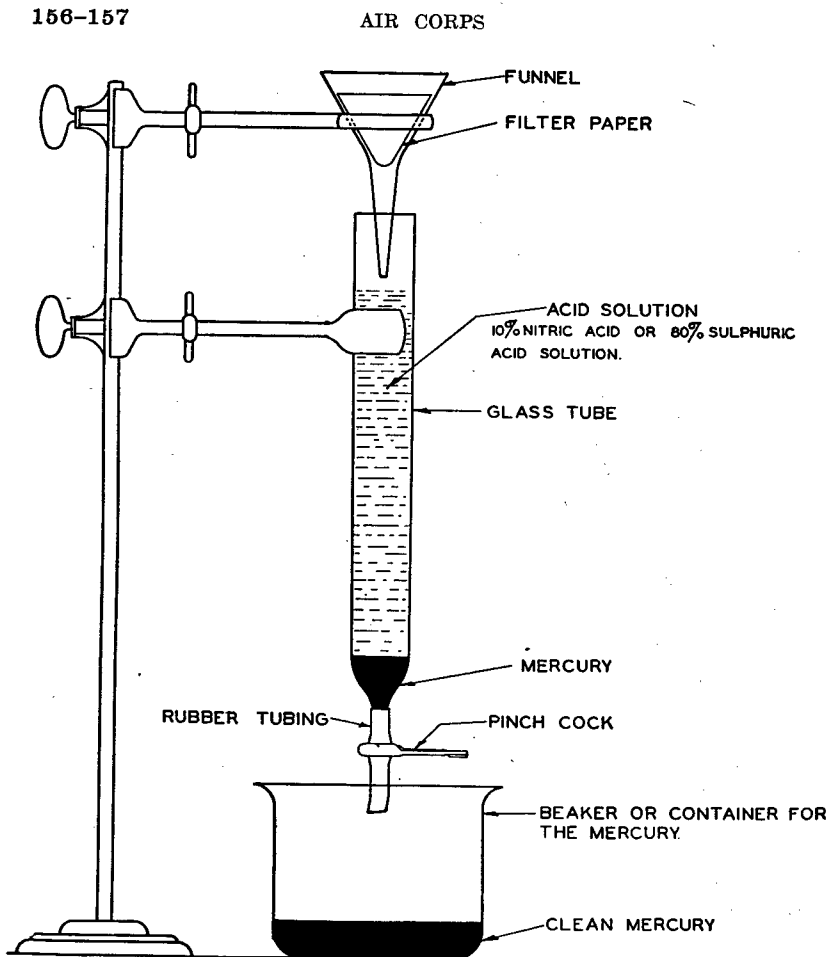

FIGURE 125.—Apparatus for cleaning mercury.

examination for cleanliness. The clean tube is then rinsed with distilled water and dried with alcohol.

(b) When refilling the manometer well, the fluid used must not contain any foreign matter. Pour the liquid into the well until it coincides with the index mark on the manometer.

157. Vacuum chamber.—*a. Purpose and use.*—The vacuum chamber serves to maintain a condition of reduced pressure. The chamber is used for testing various differential pressure and absolute pressure instruments.

b. Description.—The chamber (fig. 122) is equipped with a heavy dual safety glass window through which instruments may be observed; the chamber door is sealed with a rubber gland. Channels within the chamber provide a sliding mount for the instrument panel.

Several openings in the panel provide a means for testing various instruments simultaneously. On the rear of the panel is a small 110-volt, 60-cycle motor used to produce vibration by means of an eccentric weight attached to the end of the motor shaft. The electrical connection to the motor is completed when the panel has been entirely inserted in the chamber. A connection for the motor circuit is provided on the outside of the vacuum chamber. Suitable vents to the inside of the chamber are provided for the attachment of valves and a manometer.

c. Application.—(1) When testing an altimeter, the instrument is secured to the panel by two spring-loaded clamps. It is essential that a rate of climb indicator be installed with the altimeter on the panel to provide a means of regulating the rate of pressure change. When the two instruments have been correctly installed and adjusted, slide the panel into the vacuum chamber, close the door, place the safety latch in the locked position, and rotate the large wheel until an airtight seal is established. The motor is then placed in operation and the instruments are ready for testing.

(2) As the pressure in the vacuum chamber is decreased, comparative readings are taken between the instrument under test and the manometer. The table in the Air Corps Technical Order for the particular instrument with reference to the relationship between the manometer and the instrument readings should be consulted. The errors in the instrument readings should be within the specified tolerance.

(3) Detailed instruction pertaining to the use of the vacuum chamber when refilling and testing an aircraft compass is set forth in the Air Corps Technical Order for the particular compass.

d. Maintenance.—(1) It is essential that the seal around the door of the chamber be airtight. To maintain an airtight seal, the contacting surfaces of the chamber and door must be thoroughly clean. The gland should be closely examined for defects; the application of a thin film of glycerin may provide a seal for slight defects.

(2) To avoid damage to the latch on the chamber door, the chamber should never be subjected to more than atmospheric pressure.

158. Dead weight tester.—*a. Purpose and use.*—The tester is furnished in two ranges: a low range of 0 to 200 pounds per square inch, and a high range of 0 to 3,000 pounds per square inch. The low range tester (fig. 126①) is used for testing comparatively low range pressure gages whereas the high range tester (fig. 126②) is used for testing comparatively high range pressure gages. The tester is a master gage used for conducting a scale error test. The tests

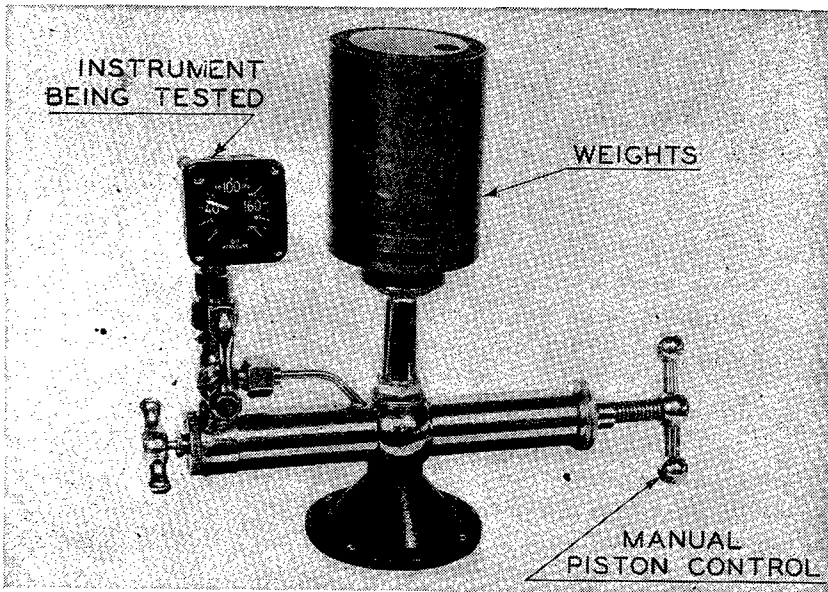

Ⓐ Low range.

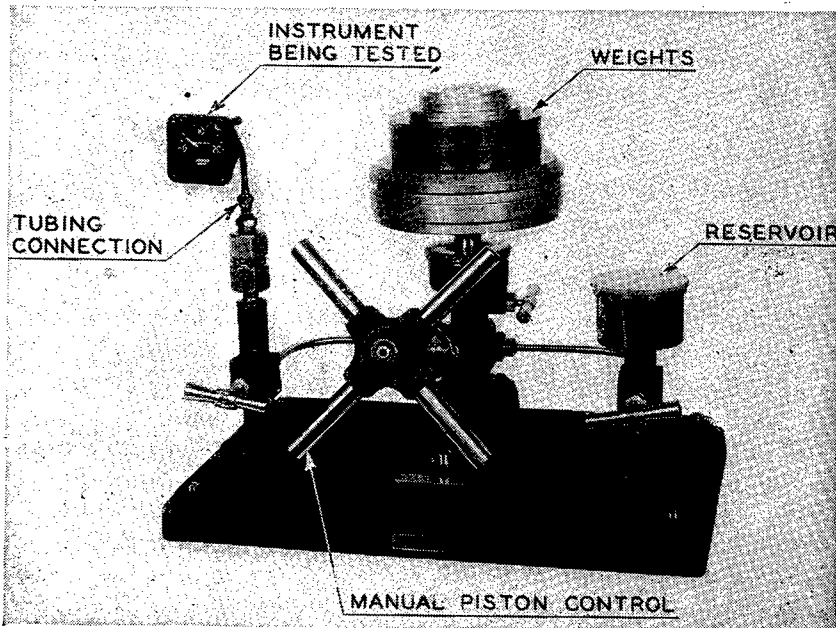

Ⓑ High range.

FIGURE 126.—Dead weight tester.

are performed by comparing the readings on the instrument under test with the pressures developed in the tester. The following gages are calibrated with the dead weight tester:

- (1) Automatic pilot oil pressure.
- (2) Fuel pressure.
- (3) Oil pressure.
- (4) Landing gear pressure.

b. Description.—Figure 126 shows the testers with gages attached for testing. Fundamentally, both the high and low pressure testers utilize the same principle of operation. Each unit consists of a manually operated piston, reservoir, weight table with piston, attaching fixture, and valves. The weights are numbered 1, 2, 5, 10, etc., which numbers designate respective pressures in pounds per square inch produced when the weights are used with the tester. The pressure produced in the tester depends upon two factors: the weight used and the cross section area of the piston. Thus, if the weight table piston has a cross section area of $\frac{1}{5}$ square inch, a 1-pound weight would produce a pressure of 5 pounds per square inch.

c. Application.—The instrument subject to test is connected to the tester. The cylinder is filled with specified oil, weights placed upon the table, and the manual piston control rotated to increase the hydraulic pressure. When the pressure reaches a value which is sufficient to lift the table from the support, a reading is recorded on the gage under test. The test procedure and the allowable error in the gage reading must be as specified in the Air Corps Technical Order for the specific instrument. During the time the gage is subjected to pressure no weights should be removed from the tester table.

d. Maintenance.—The following rules of maintenance should be observed:

- (1) Inspect for and repair leaks.
- (2) Keep unit clean.
- (3) Use specified oil.
- (4) Store unit in a dry room.
- (5) Carefully handle unit and all accessories.
- (6) Place all accessories in their respective receptacles.

159. Voltmeters.—*a. Purpose and use.*—A voltmeter is an instrument for measuring the voltage or potential difference between two points of an electrical circuit.

b. Description.—There are many types of voltmeters. For test purposes the Air Corps uses d-c, alternating d-c, and a-c voltmeters. The range of each instrument depends upon its application.

(1) The mechanism of a d-c voltmeter consists essentially of a permanent magnet and a movable coil to which a pointer is attached. Actually, a d-c voltmeter is a D'Arsonval type galvanometer consisting of a high resistance connected in series with a movable coil (fig. 127). This type of instrument utilizes a scale of uniform graduations.

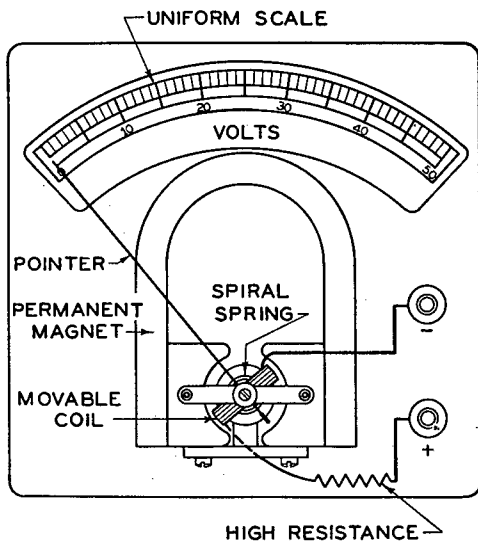

FIGURE 127.—D-c voltmeter.

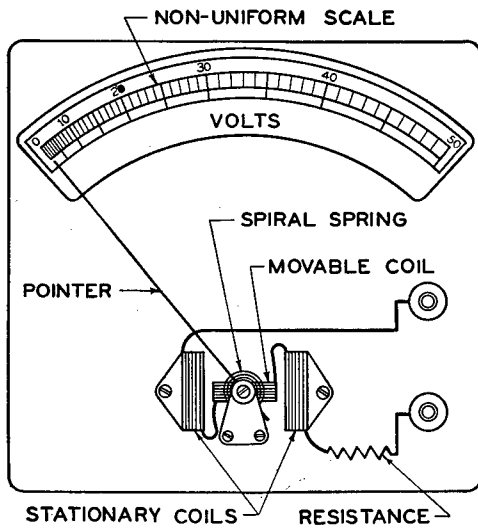

FIGURE 128.—Dynamometer type voltmeter.

(2) The alternating d-c voltmeter may be of the dynamometer or rectifier type.

(a) The mechanism of a dynamometer type voltmeter (fig. 128) consists of stationary coils placed at right angles to a movable coil. A pointer is attached to the movable coil. A resistance is also connected in series with the movable coil. The scale on this instrument has nonuniform graduations.

(b) The rectifier type of voltmeter is basically a direct current instrument adaptable for use with alternating current by the addition of a rectifier. This type of instrument is equipped with a scale of uniform graduations.

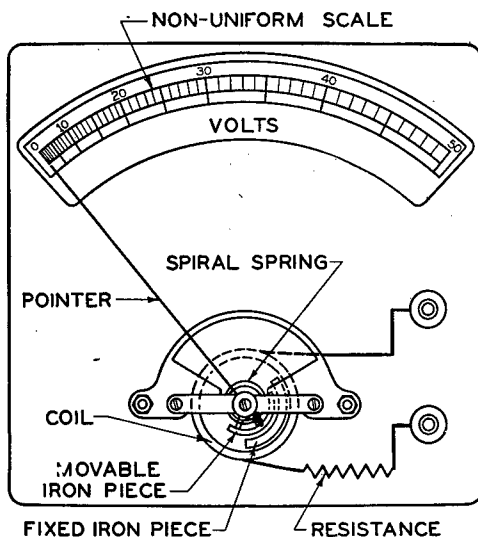

FIGURE 129.—Iron vane-type voltmeter.

(3) The most common a-c voltmeter is the iron vane type which is sometimes referred to as the movable iron type. A simplified diagram of this mechanism is shown in figure 129. It consists of a cylindrical coil with two laminated iron pole pieces, one fixed and the other movable. The pointer is attached to a movable pole piece. This type voltmeter is equipped with a scale having nonuniform graduations.

c. Application.—(1) Figure 130 shows a simple electrical circuit consisting of a source of supply, an ammeter, a resistor or load, and a voltmeter.

The ammeter is explained in paragraph 160. Before connecting a voltmeter into the circuit the following should be noted:

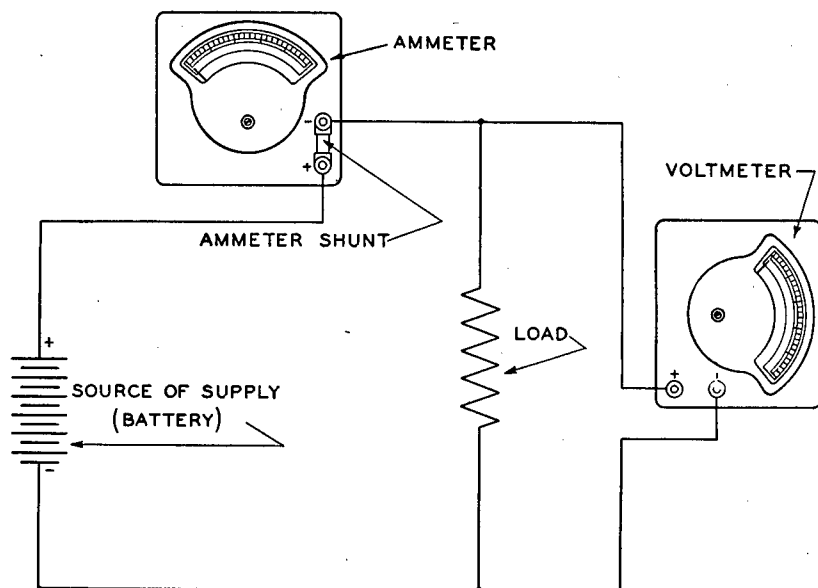

FIGURE 130.—Simple electrical circuit.

(a) Source of electrical supply, whether alternating current or direct current.

(b) Range of the voltmeter.

(2) When measuring voltage it is essential that the proper type of instrument is used. A majority of the a-c voltmeters (except those which use transformers) can be used to measure direct current. However, in such case the accuracy of the reading is impaired. For example, the dynamometer type of voltmeter requires about five times as much current as a d-c voltmeter of the same rating. Furthermore, a dynamometer type instrument consumes an appreciable amount of power which may also affect the reading. These factors should be taken into consideration when using voltmeters.

(3) When using a multiple range voltmeter always place the selector switch in a position to exceed the maximum value of the voltage to be measured. Figure 131(2) shows a multiple range voltmeter.

d. Maintenance.—(1) A voltmeter requires no lubrication.

(2) A voltmeter must always be handled so as to avoid jarring.

(3) Mechanical zero adjustment on the voltmeter is essential for correct indication of the instrument. If at any time (when not in use) the indication is not zero, adjust the pointer with a screw driver so that the pointer is in line with the zero mark.

(4) When doubt exists concerning the accuracy of a voltmeter, check the reading of the instrument against that of another voltmeter known

to be correct; if in error the instrument should be sent to the depot for calibration (deflection potentiometers with volt and shunt boxes are used to calibrate voltmeters and ammeters).

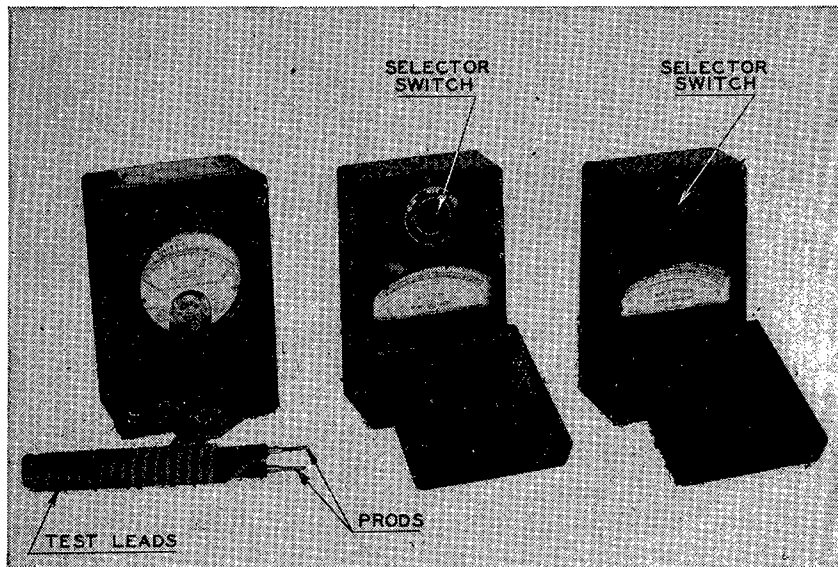

① Ohmmeter (continuity meter). ② Multiple range voltmeter. ③ Multiple range ammeter.

FIGURE 131.—Electrical instruments for measuring resistance, voltage, and current.

160. Ammeters.—*a. Purpose and use.*—An ammeter is an instrument for measuring the rate of flow of current in an electrical circuit.

b. Description.—(1) Fundamentally, the ammeter is similar in construction to the voltmeter. The D'Arsonval mechanism is used for the d-c ammeter (fig. 132). The dynamometer and rectifier types of ammeters are used for small current measurement. The iron vane ammeter is used commonly for large a-c measurement.

(2) To measure large direct currents, an ammeter is connected in parallel with a shunt. A shunt is merely a low resistance which causes the larger portion of current to be diverted from the moving coil of the ammeter. By using shunts of different resistances, it is possible to utilize a number of ammeter scales and ranges. Figure 131③ shows an ammeter which is provided with a selector switch for choice of any of three scale ranges.

c. Application.—A simple electric circuit with an ammeter and an external shunt is shown in figure 130. An ammeter must always be connected in series with the load. The resistance of an ammeter is

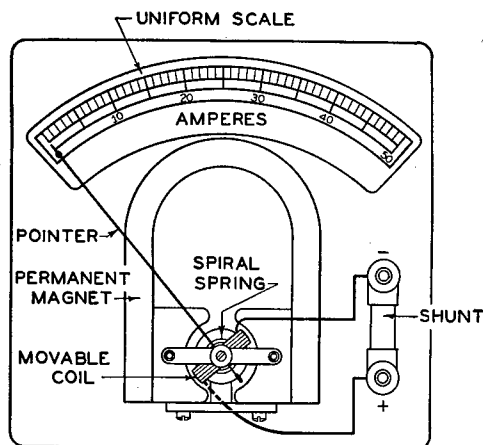

FIGURE 132.—D'Arsonval type ammeter.

low and if connected in parallel serious damage to the instrument would result.

d. Maintenance.—The maintenance outlined for voltmeters in paragraph 159 is also applicable to ammeters.

161. Ohmmeters.—*a. Purpose and use.*—An ohmmeter is an instrument for measuring the resistance of electric circuits or resistors.

b. Description.—The direct reading ohmmeter and precision ohmmeter are the two types used in the Air Corps.

(1) The direct reading ohmmeter (continuity tester) illustrated in figure 131① is provided with a scale for reading the value of the resistance in ohms. The instrument consists of a sensitive voltmeter, a source of electrical supply (battery), and a rheostat. The instrument operates on the principle that when a resistance is connected in series with a voltmeter and a source of supply, the value of the resistance in ohms is indicated by the decrease in pointer deflection. The scale of the instrument is calibrated in ohms to show directly the value of the resistance.

(2) The precision ohmmeter (fig. 133) is basically a Kelvin double bridge. A simplified diagram is shown in figure 134. This bridge eliminates the effect of contact resistance (present in the Wheatstone bridge) and as a result provides a method of measuring very small resistances.

c. Application.—(1) The direct reading ohmmeter is used on aircraft to check the continuity of an electrical circuit and the approximate resistance of electric thermometer bulbs. Before proceeding to measure a resistance, select the desired range, short circuit the instrument prods, and adjust the rheostat for maximum deflection of the in-

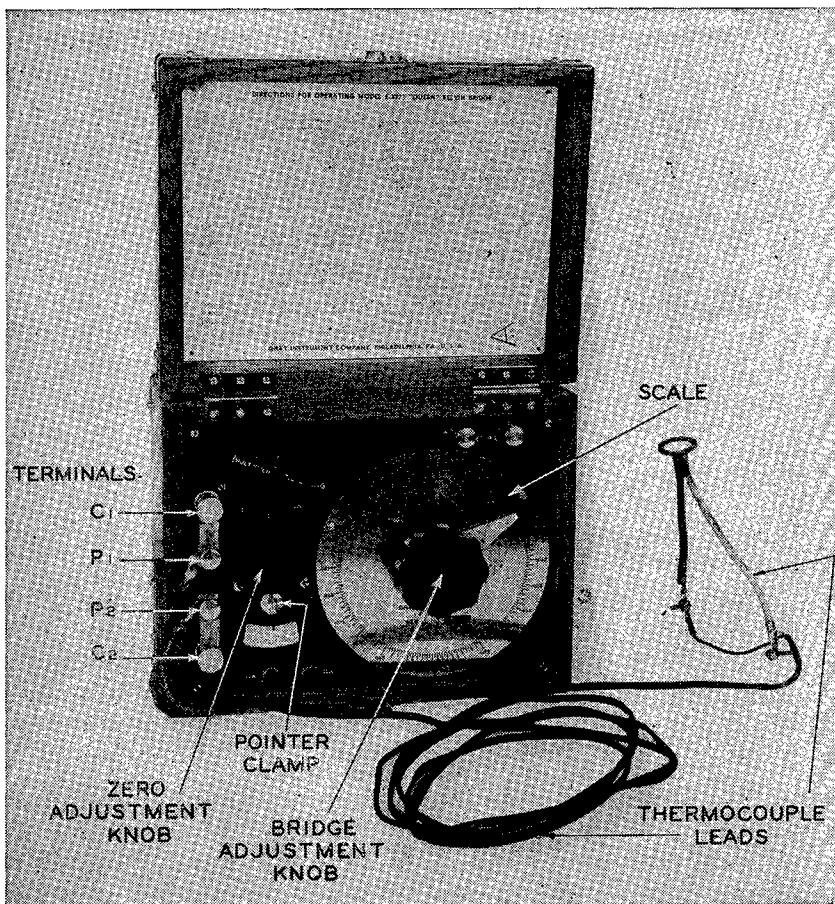

FIGURE 133.—Precision ohmmeter as used for measuring resistance.

indicator (zero ohm reading). This adjustment is necessary to compensate for any variation in the battery voltage and must be performed as each range is selected. Next, place the prods across the resistor (or circuit) to be measured and read the indication on the instrument.

(2) The precision ohmmeter is used accurately to measure resistance (not to exceed 11 ohms). The instrument is used frequently to determine the resistance of bonding.

(a) When using the precision ohmmeter to test the resistance of a resistor in the range between 1 and 11 ohms, it is necessary to provide the ohmmeter with two shunts: one between the terminals C_1 and P_1 and the second between the terminals C_2 and P_2 (fig. 133). To obtain accurate results, place the instrument in a level position and proceed by connecting the unknown resistance (for example, thermo-

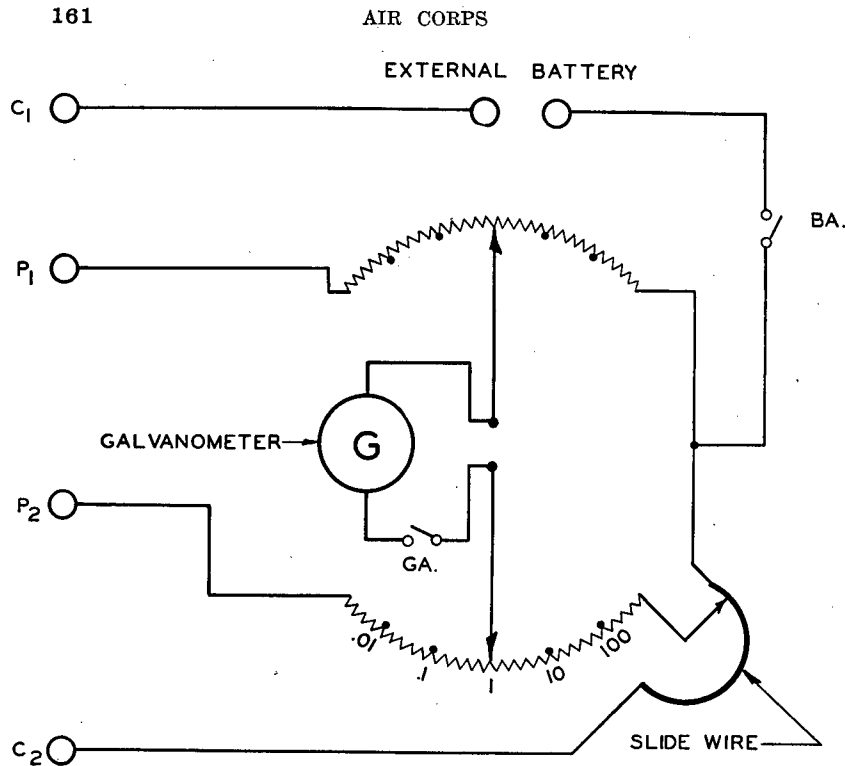

FIGURE 134.—Simplified diagram of Kelvin double bridge.

couple leads) between the terminals P_1 and P_2 . Place the multiplier switch in the correct position. Release the galvanometer pointer by moving the clamp and check the mechanical zero setting. Next, lock the galvanometer key GA , press key BA , and note the galvanometer deflection. Adjust the bridge and when no deflection is noted on the galvanometer the instrument is balanced. The resistance is determined by multiplying the scale reading by the ratio switch setting (indicated by multiplier).

(b) If it is necessary to use connecting leads between the instrument and the unknown resistance, the resistance of the connecting leads must be determined and subtracted from the total resistance measured by the instrument; the remainder will be the value of the unknown resistance.

(c) When checking the resistance or bonding, care should be exercised to remove any oxides from the bonding with emery cloth before proceeding with the check. With the clamps and prods in firm contact as shown in figure 135, the resistance of the bonding is determined as heretofore outlined.

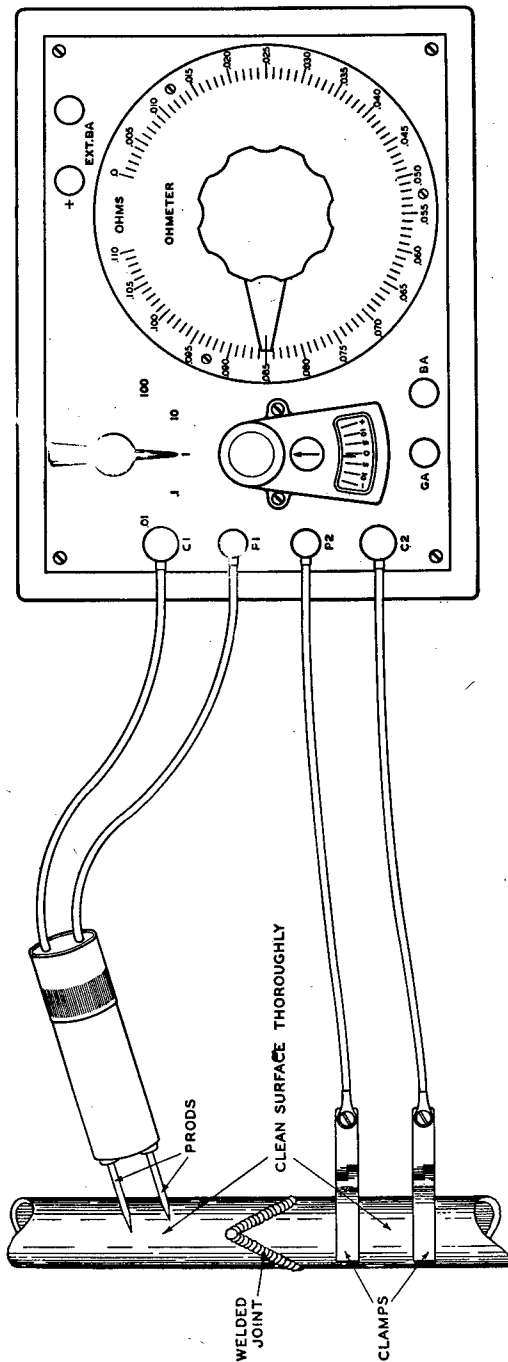

FIGURE 135.—Method of determining resistance of a welded bond with precision ohmmeter.

d. Maintenance.—It is desirable periodically to inspect instruments of this type to insure accurate results.

(1) To check the precision ohmmeter, use a standard 2-ohm resistance connected between the terminals P_1 and P_2 and proceed in the manner as heretofore outlined. If the reading obtained is satisfactory, it is reasonable to assume that the instrument is accurate within the limits of the scale range.

(2) At times it will be necessary to clean the variable resistor, contact points, and switch points on the precision ohmmeter. This maintenance is required when erratic and unstable readings are noticeable on the galvanometer while performing adjustments. Never use an abrasive to clean the resistor or contact points. Such action will result in the removal of metal, thus changing the resistance of the resistor and impairing the accuracy of the instrument. Resistors and contact points should be wiped with a clean cloth dampened with benzine; this should be followed with application of a cloth greased with a small quantity of petroleum jelly. After cleaning any excess jelly should be removed.

(3) The precision ohmmeter is a very sensitive instrument and should be protected against jarring or bumping. When not in use, the galvanometer pointer should be locked with the clamp provided on the instrument. It is to be noted that the precision ohmmeter must not be lifted or carried by grasping the carrying case lid (the hinge pins slide out of the hinge with a lateral movement).

162. Thwing potentiometer.—*a. Purpose and use.*—The potentiometer is an instrument used for accurately measuring and comparing voltages. As applied to aircraft, the primary use is in the performance of scale error tests upon a synchronism indicator and a cylinder head temperature indicator, provided the voltage to be measured does not exceed 0.1 volt (100 millivolts).

b. Description.—The Thwing potentiometer is entirely self-contained and includes necessary batteries and a standard cell. Figure 136 shows a simplified circuit of a potentiometer. The standard cell is the source of comparative voltage. At no time should the standard cell be used as a source of supply for testing an instrument. This cell is a vital part of the instrument and if misused will terminate the useful application of the potentiometer until the cell is replaced. On the Thwing potentiometer the M_1 rheostat dial reads in multiples of 10 millivolts; the M_2 rheostat dial has a range of 11 millivolts with unit graduations of 0.05 millivolt.

c. Application.—(1) Figure 137 shows a Thwing potentiometer properly connected to perform a scale error test on a synchronism indicator. Before proceeding to conduct this type of test, it is advisable to con-

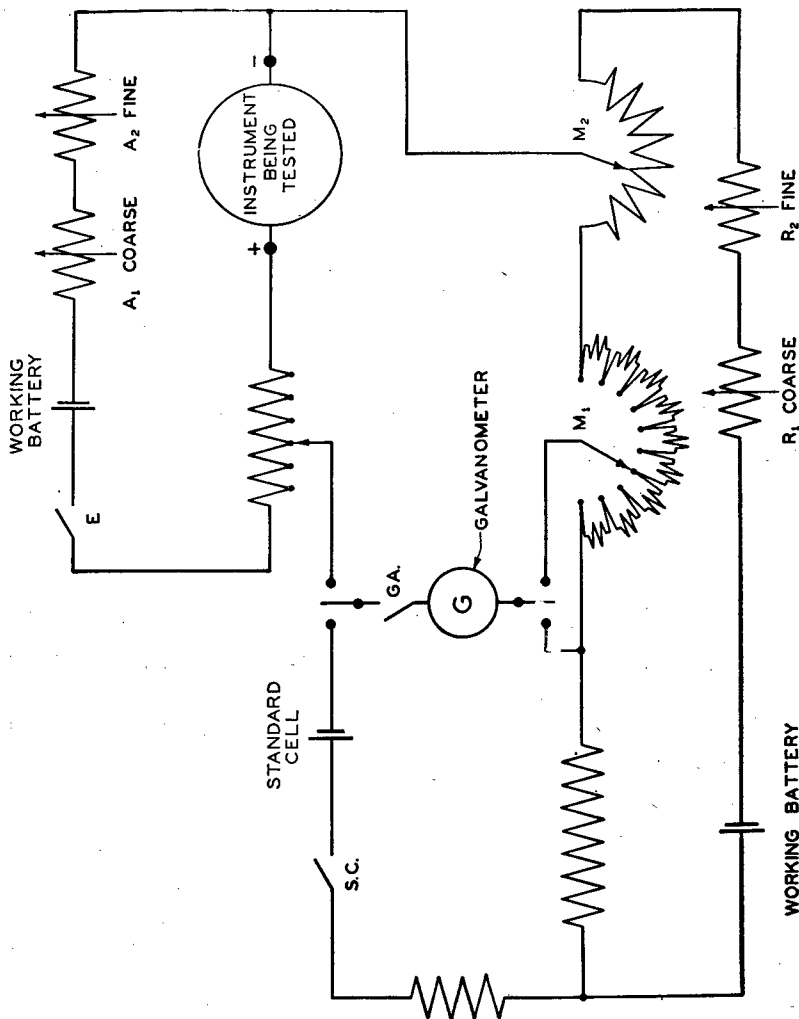

FIGURE 136.—Simplified wiring diagram of potentiometer.

sult the Air Corps Technical Order for the specific instrument to obtain tolerances and details (including the correct value of lead resistances to be used). However, the maximum voltage required for full scale deflection of the instrument to be tested must not exceed 0.1 volt as this is the range limit of the Thwing potentiometer. After checking the mechanical zero of the instrument, connect its positive (+) and negative (-) terminals to the correspondingly marked terminals of the potentiometer.

(2) To operate the potentiometer, check the mechanical zero setting of the galvanometer. Place switch *A* in the "open" (up) position and perform the electrical zero adjustment by varying rheostats *R*₁ (coarse

adjustment) and R_2 (fine adjustment), observing the galvanometer with the keys SC and GA in their "closed" positions. The galvanometer pointer will give a zero indication when the instrument is properly balanced.

(3) Set the couple lead resistance (selector switch) to the number nearest to the value of the lead resistance specified in the Air Corps Technical Order. Lock (by depressing and rotating) key E in the "on" position. The equipment is now ready for a scale error test.

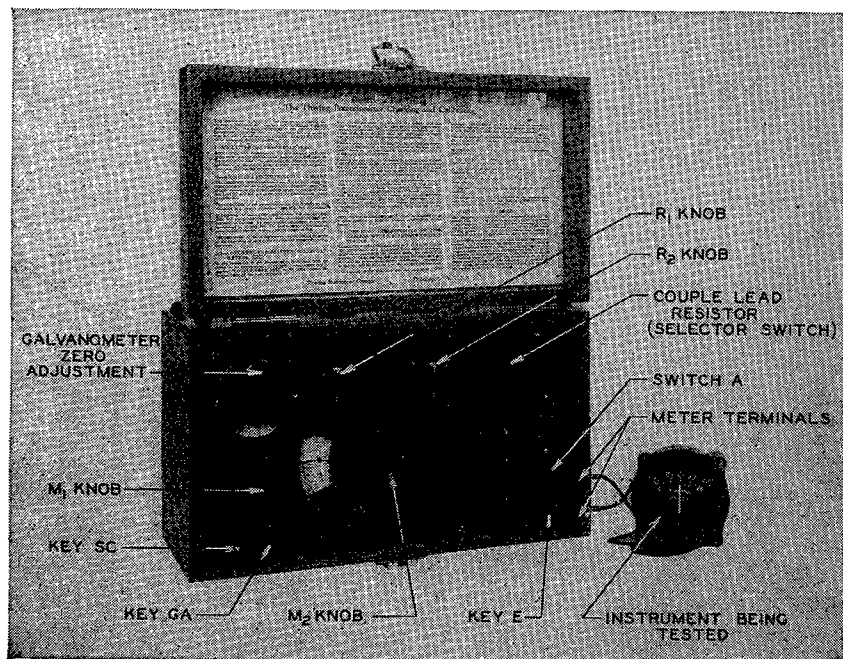

FIGURE 137.—Thwing potentiometer.

(4) Adjust rheostats A_1 (coarse adjustment) and A_2 (fine adjustment) to locate the pointer of the instrument being tested on the first test point on the scale.

(5) To determine the voltage across the terminals of the instrument, place switch A in the "closed" (down) position and balance the potentiometer by tapping galvanometer key GA , adjusting rheostats M_2 and M_1 until the galvanometer pointer shows no deflection when the key GA is held down. The sum of the readings of M_1 and M_2 indicates the applied voltage in millivolts. The difference between the sum of the readings of rheostat dials M_1 and M_2 and the number of millivolts specified in the Air Corps Technical Order should be within

the limits of the specified tolerance. The above procedure is followed for all the test points on the instrument.

(6) As the pointer of the synchronism indicator may be deflected to the left or right, a recommended procedure is to set at one test point (either left or right) and reverse the meter terminals on the potentiometer to obtain the corresponding test point on the opposite side of the scale. This obviates two separate tests on the instrument.

(7) After completing a test with the Thwing potentiometer, release key *E* to avoid closing the instrument lid with this key in the "on" position.

d. Maintenance.—Maintenance as set forth for the precision ohmmeter (par. 161*d*(2)) is applicable to the Thwing potentiometer. It is to be noted that the potentiometer must not be lifted or carried by grasping the carrying case lid (the hinge pins slide out of the hinge with a lateral movement).

163. Decade box.—*a. Purpose and use.*—A decade box provides a resistance which may be varied by tenths, units, tens, hundreds, and thousands of ohms. The decade box is suitable for use where precise resistance is required for testing electrical instruments.

b. Description.—Figure 138 shows a simplified wiring diagram of a decade box. A resistance of 0.1 to 9999.9 ohms may be obtained with this unit.

c. Application.—(1) The decade box (fig. 139) may be substituted for a resistance bulb when testing an electric thermometer. With the instrument attached to a source of voltage and the decade box set for resistance as specified in the Air Corps Technical Order for the particular instrument, check the instrument readings. The readings should be within the tolerance specified in the order.

(2) It is to be noted that before application of voltage to the circuit in which the decade box is used, sufficient resistance must be set (in the box) to restrict the flow of current to a value which will not be excessive.

d. Maintenance.—Oxides and other impurities should be removed from contacts and contact arms to eliminate a source of error. Contacts and contact arms may be cleaned in accordance with the procedure as outlined for the precision ohmmeter (par. 161*d*(2)).

164. Vapor pressure thermometer tester.—*a. Purpose and use.*—The vapor pressure thermometer tester (model AVT-CHT-P) is used to perform a scale error test on a vapor pressure thermometer. The tester has a temperature range of from -40° C. to 200° C.

b. Description.—The thermometer tester (fig. 140) is a compact device consisting of a complete refrigerating unit and a two-tube container (evaporator) in which the vapor pressure thermometer bulbs

are placed. The refrigerating unit consists of a two-cylinder, air-cooled, reciprocating compressor driven by a 1/3-hp, 110-volt, 60-cycle, single phase motor. The refrigerant (liquid) is nontoxic, noninflam-

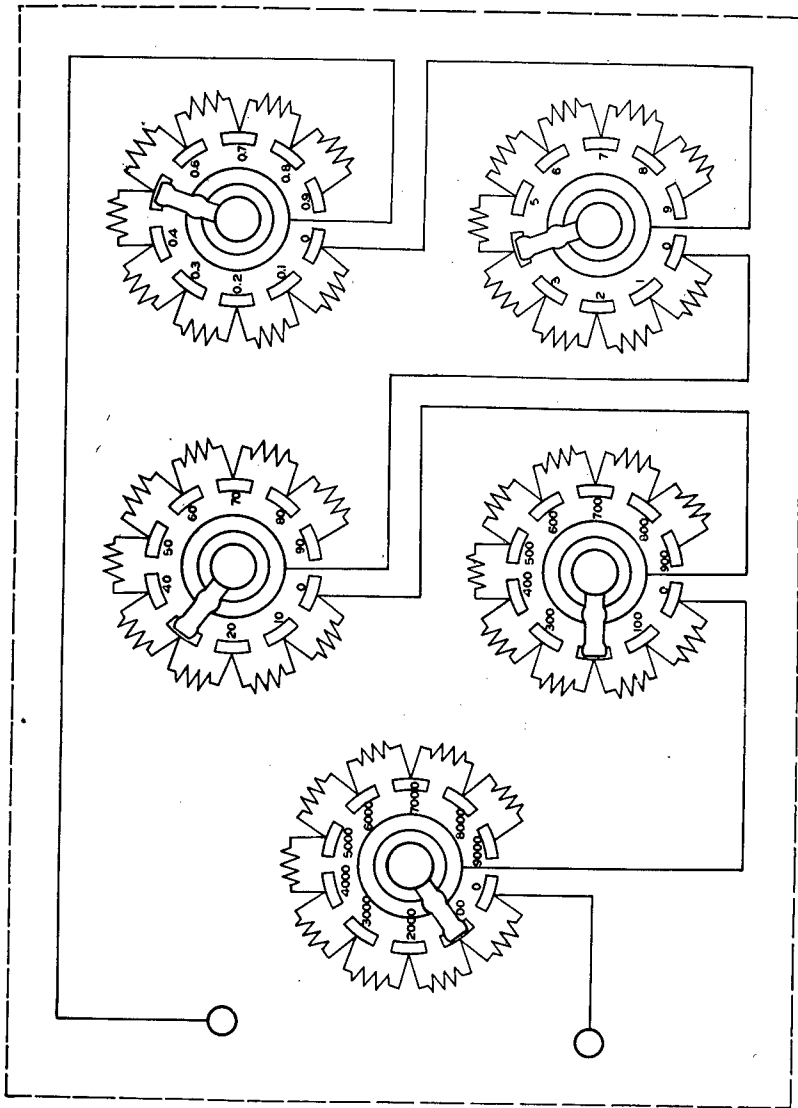

FIGURE 138.—Simplified diagram of decade box.

mable, and noncorrosive. The container houses the cooling coil, electrical heating element, and a liquid which will not freeze at -40°C . nor boil at 200°C . The liquid acts to transfer cold or heat from the

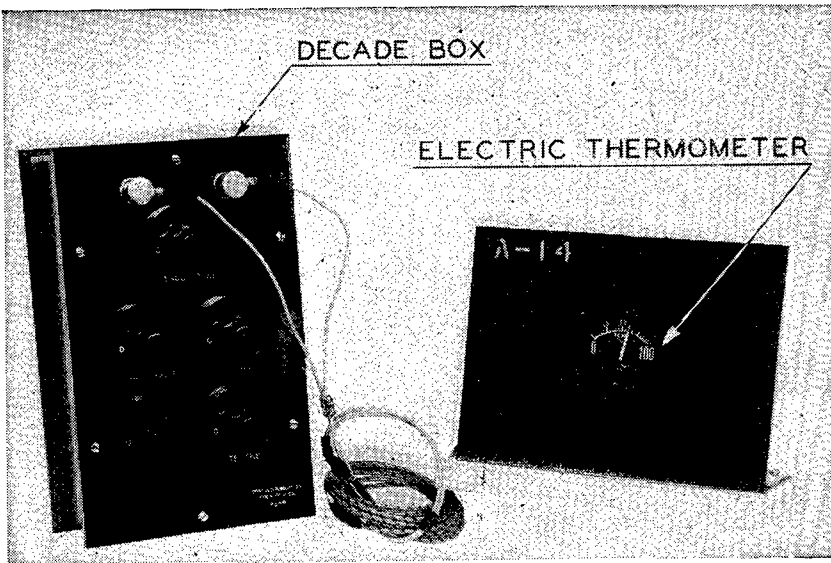

FIGURE 139.—Decade box as used for thermometer test.

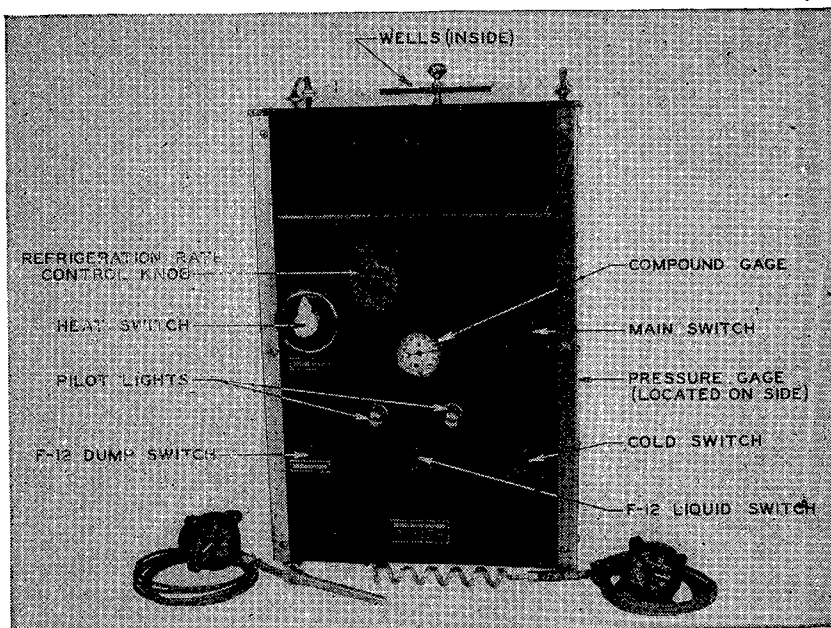

FIGURE 140.—Vapor pressure thermometer tester.

cooling coil or heating element to the thermometer bulb. A thermostat, pressure control, and refrigerant safety control are provided for regulation of cold and heat cycles.

c. Application.—Insert the bulb of the thermometer to be tested in one well of the tester, and the bulb of a master thermometer in the other well.

(1) *Cold cycle.*—(a) Before operating the tester for a cold cycle, place all switches in the “off” position. Then, place the main switch in the “on” position. Next, place the cold switch in the “on” position. This starts the refrigerating unit. Note the reading on the compound gage. During the first cycle of operation of the refrigerating unit, a pressure between 20 and 70 pounds per square inch is registered on the compound gage. After the compressor has been in operation for a few minutes, the indicator pointer will drop below zero to the vacuum side. Next, place F-12 liquid switch to the “on” position. This allows refrigerant to enter the cooling coil in the evaporator. When the F-12 liquid switch is in the “on” position the left pilot light is illuminated. This light remains illuminated during the period the tester operates on a cold cycle. A pressure gage is located on the right side of the tester when viewed from the front. During operation, this gage will register from 120 to 150 pounds per square inch, and the indication will gradually recede to 90 pounds per square inch at -40° C.

(b) Readings may be now taken on the instrument under test and compared with those of the master thermometer. In each case, the error of the instrument under test shall be within the tolerance specified in the Air Corps Technical Order for the particular instrument. The cooling rate is rapid at the beginning of the cold cycle and decreases slowly in the range from 0° C. to -40° C. If the cooling rate is too rapid to compare accurately readings of the instrument under test with the master thermometer, slightly open the refrigeration rate control valve to reduce the rate of cooling. When it is desired to stop operation of the cold cycle, all switches are placed in the “off” position.

(2) *Heat cycle.*—(a) Before operating the tester for a heat cycle place all switches in the “off” position. Then place the main switch in the “on” position. Next, turn the heat switch to the “high” position. The right pilot light will remain illuminated during the heat cycle. The temperature will rise until 200° C. is reached. If the rate of heating is too rapid to compare accurately readings between the master thermometer and the instrument under test, place the heat switch to the “medium” or “low” position. If any amount of refrigerant is left in the cooling coil when heat is applied, a high pressure will

result (indicated on the compound gage). The F-12 dump switch should be left in the "on" position to prevent an excessive pressure from building up in the cooling coil and in the low side of the compressor. After completion of the heat cycle, all switches should be placed in the "off" position.

(b) The usual procedure is to test a thermometer with the cold cycle and complete the test with the use of the heat cycle. If the heat cycle is accomplished first, the cold cycle must not be placed in operation until the liquid has cooled to room temperature to avoid damage to the tester.

(c) When doubt exists concerning any phase of operation of the tester, the manufacturer's operating instructions should be consulted.

d. *Maintenance.*—The following features are applicable to maintenance of the tester:

(1) Slippage of the V-belt may be minimized by application of castor oil to the sides of the belt.

(2) Condenser should be blown out with compressed air at intervals of three months.

(3) Do not permit lint or dust to collect in the fan.

(4) Motor bearings should be oiled at intervals of 6 months.

(5) Compressor need not be lubricated.

(6) A suitable inspection, lubrication, and maintenance record should be kept.

165. Analysis cell test box (SAAD-E-70).—*a. Purpose and use.*—This instrument is used to test the analysis cell of a fuel mixture indicator for electrical zero adjustment. In some instances it may be necessary to use the test box to heat the filaments of the analysis cell to remove the carbon residue.

b. Description.—The test box (fig. 141) consists of four 1½-volt dry cells, a milliammeter, galvanometer (micromammeter), rheostat with switch, two toggle switches, four receptors (numbered 1, 2, 3, and 4), and four sets of leads (to accommodate the various types of

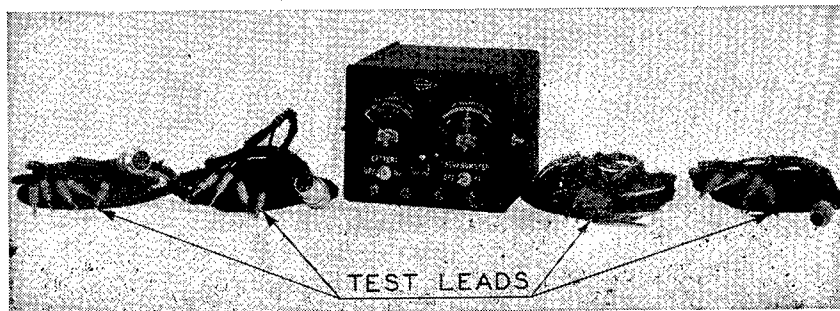

FIGURE 141.—Analysis cell test box (SAAD-E-70).

analysis cell). All leads in each set are banded conveniently for guidance of the operator.

c. Application.—(1) Carefully read the operating instructions accompanying each test box and consult the Air Corps Technical Order for the particular analysis cell for details and wiring diagrams. To protect the galvanometer of the tester, it is recommended that a continuity meter be used to check the spirals (resistors) of the bridge in the analysis cell for open spirals.

(2) Before completing any connections, place all switches, including the rheostat switch, in the "off" position. Select the proper set of test leads, attach the cannon plug (or alligator clips in the event that the cannon plugs are not suitable) to the analysis cell, and place the banana plugs in their respective receptors. The banding (used for numbering) on the leads shows continuity of the wire and should not be confused with the numbers on the analysis cell. Place the galvanometer switch in the "on" position and observe the pointer. If any deflection is noticeable, the bridge in the analysis cell is unbalanced and requires an adjustment. As the adjustment for each type analysis cell may vary, the Air Corps Technical Order for the particular cell should be consulted for details. When adjustment has been performed, the galvanometer should indicate zero.

(3) In the event accurate adjustment cannot be performed, it is possible that carbon residue has accumulated on the spirals in the analysis cell and must be removed. In many instances this residue may be removed by using the test box to heat the filaments of the analysis cell. The Air Corps Technical Order for the particular analysis cell and the operating instructions for the test box should be consulted for the correct value of current to be applied and the length of current application. Before applying the heating current to the analysis cell, place the galvanometer switch in the "off" position. This is a precaution which must be observed to prevent damage to the galvanometer. Then place the battery switch in the "on" position and by means of the rheostat adjust the current to the desired value. For an analysis cell which incorporates a ballast tube a special procedure must be followed. The methods are outlined in the operating instructions accompanying the test box.

d. Maintenance.—(1) The test box requires no periodic maintenance. If the voltage in the test box decreases to a value which does not permit sufficient operating current, the dry cells of the test box should be replaced.

(2) The instrument should be protected from dampness and jarring.

(3) When not in use, the switches and rheostat should be in the "off" position.

166. Tachometer test stand.—*a. Purpose and use.*—The tachometer test stand shown in figure 142 is available to perform scale error tests on centrifugal, chronometric, or electric tachometers.

b. Description.—(1) The test stand consists of a housing which contains the primary gear mechanism for the operation of five verti-

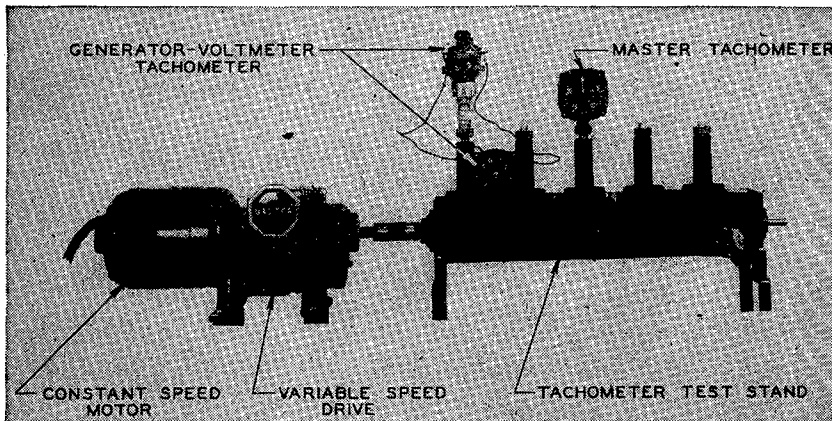

FIGURE 142.—Tachometer test stand.

cal spindles. A master tachometer, usually of the chronometric type, is attached to one of these spindles. The main drive shaft extends through the ends of the housing; an adapter protrudes from the rear side of the housing and is used as an auxiliary drive.

(2) The tachometer test stand may be operated by a variable speed motor or a constant speed motor equipped with a variable speed drive.

c. Application.—Figure 142 shows the assembly with a generator-voltmeter tachometer installed for testing. To prevent damage to the instruments attached to the test stand, the variable drive (or variable speed motor, if used) must be placed in the “slow speed” position before starting. Adjust the speed so that the master tachometer indicates the rpm specified in the Air Corps Technical Order for the tachometer under test. Comparative readings of the master tachometer and the aircraft tachometer are observed at specified consecutive speeds. If the readings of the master and aircraft tachometers differ by more than the tolerance specified in the Technical Order, the instrument should be returned to the depot for repairs.

d. Maintenance.—Required maintenance is as follows:

- (1) Keep the unit clean.
- (2) Inspect for and repair leaks.
- (3) Lubricate, as needed, the gear mechanism of the test stand and the drive unit.

167. Turntable assembly.—*a. Purpose and use.*—The turntable assembly (fig. 143) is designed to rotate a plate about a vertical axis at a selected rate of speed. The turntable assembly is used primarily for testing a bank and turn indicator, but is also employed to conduct tests on a magnitude of turn indicator and an aircraft compass.

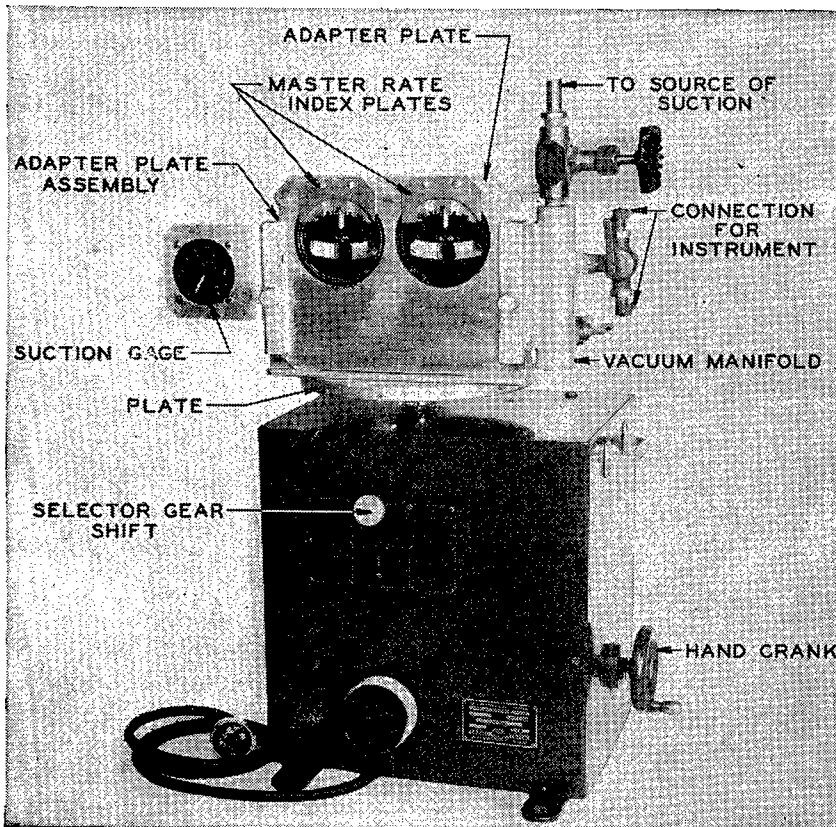

FIGURE 143.—Turntable assembly.

b. Description.—The turntable assembly consists of a gear train with gear ratios to govern the speed of the turntable. A selector gear shift is employed to obtain four distinct rates of rotation ranging from 36° to 1080° per minute. Optional direction for right or left turns is obtained by setting the selector gear shift to the right or left of the neutral position. An adapter plate assembly, complete with vacuum manifold, hose connections, valves, suction gage, and special clamps, is located on the plate of the unit. The plate is attached securely to the drive shaft to insure correct alignment.

When testing an aircraft compass, a special adapter plate for each type of compass is furnished to simulate aircraft installation.

c. Application.—(1) *Bank and turn indicator.*—Properly affix the instrument to be tested to the turntable assembly and complete the connections to a vacuum source. Next, adjust the suction setting to the value specified in the Air Corps Technical Order for the instrument, and allow the gyroscopic rotor to attain operating speed. Place the selector gear shift in position for the desired direction of rotation and turntable speed, and start the electric motor. Observe the pointer deflection with respect to the master rate index plate. The error in deflection must be within the tolerance specified in the Technical Order for the instrument. If a damping or sensitivity adjustment is required, slightly turn the adjusting screw, again check the instrument on the turntable assembly, and repeat the adjustment and check until the indication is within the tolerance.

(2) *Magnitude of turn indicator.*—Affix the instrument to a proper adapter (par. 168) and mount on the adapter plate assembly. Connect the instrument to a source of vacuum, adjust the suction to the desired value, and allow the gyroscopic rotor to attain full speed. Set and uncage the instrument knob, place the selector gear shift of the turntable assembly to desired turntable speed of rotation, and start the motor. The error in the indication must be within the tolerance specified in the Technical Order for the instrument.

(3) *Compasses.*—When conducting a damping test, mount the instrument as shown in figure 144 or 145 (depending upon the type of compass) and allow the compass needle to cease oscillating. With the selector gear shift placed in position for desired turntable speed of rotation, permit the turntable to move through one complete revolution and note the position of the card in degrees at the completion of the turn. The error in the reading must be within the tolerance specified in the Technical Order for the instrument.

d. Maintenance.—The following rules of maintenance should be observed:

- (1) Keep the unit clean.
- (2) Use and store the unit in a clean, dry room.
- (3) Generally inspect unit and accessories.
- (4) Lubricate the unit as needed.
- (5) Carefully handle the unit and all accessories.
- (6) Keep a record of inspection, lubrication, and maintenance.

168. Gyroscopic instrument test fixture.—*a. Purpose and use.*—This fixture (fig. 146) is used for performing tests on the magnitude of turn indicator and the flight indicator.

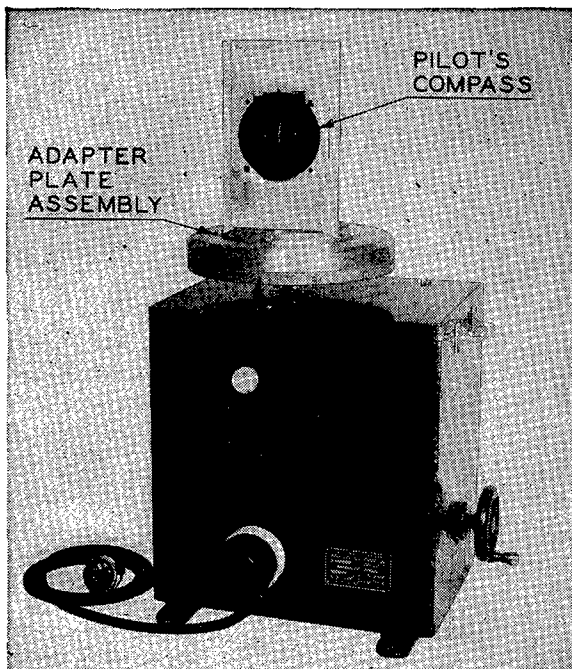

FIGURE 144.—Damping test of pilot's compass.

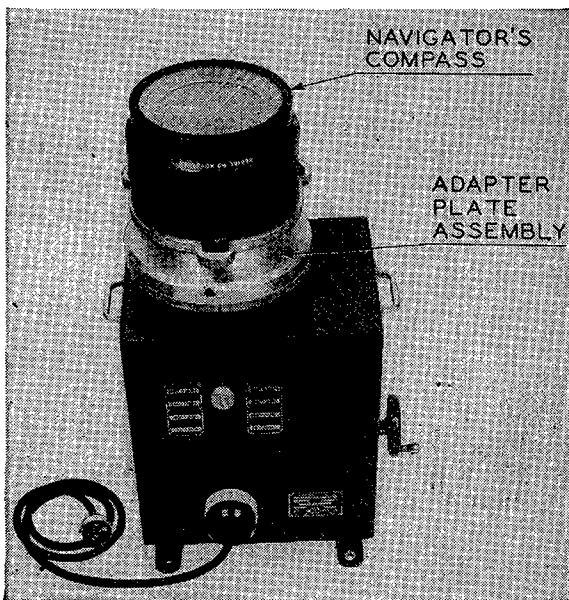

FIGURE 145.—Damping test of navigator's compass.

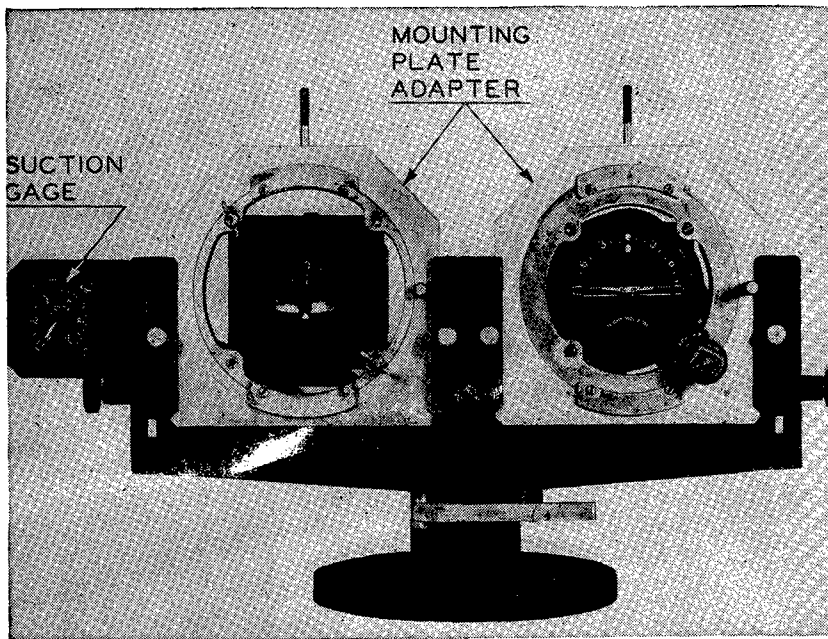

FIGURE 146.—Gyroscopic instrument test fixture.

b. Description.—The fixture consists of a swivel frame with provision for two individual mounting plate adapters which may be secured in a sliding groove by means of knurled thumbscrews. The instrument affixed to the mounting plate adapter may be rotated about the lateral, vertical, and longitudinal axes. A vacuum manifold with suitable valves and attachment fittings is affixed to the rear of the fixture. A suction gage is located on the left side of the fixture.

c. Application.—(1) The fixture must be mounted in a level position and firmly attached to the test bench. Fasten the instruments to the mounting plate adapters, complete all necessary connections to the vacuum source, and adjust the suction to a valve as specified in the Air Corps Technical Orders for the particular instruments under test.

(2) Perform the test procedure for each instrument as outlined in the Technical Order. The error should be within the specified tolerance.

d. Maintenance.—Carefully handle and clean the fixture and accessories.

169. Portable vacuum pump assembly.—*a. Purpose and use.*—The portable vacuum pump assembly (fig. 147) provides a source of vacuum for testing gyroscopic instruments in the shop or in the hangar.

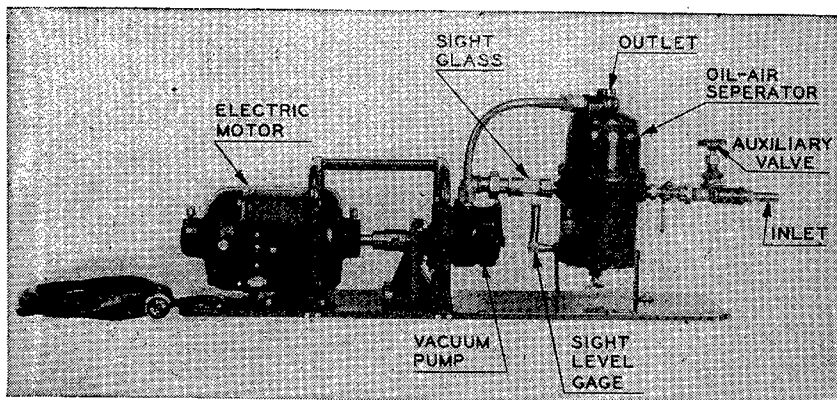

FIGURE 147.—Portable vacuum pump.

b. Description.—The portable vacuum pump assembly consists of a single phase, 110-volt, 60-cycle electric motor ($\frac{1}{3}$ -hp), coupled to a vane type vacuum pump which in turn is connected to an oil-air separator. Located between the vacuum side of the pump and the oil-air separator is a sight glass connector which serves to indicate the flow of oil for pump lubrication. Suitable valves and nipple connections (for the attachment of rubber hose) are provided.

c. Application.—Connect rubber tubing from the vacuum inlet to the fixture or instrument line. When the vacuum relief valve on the aircraft is used to adjust the volumetric flow, regulate the valve to secure the maximum rate of flow, thereby reducing the load on the pump. Observe the suction gage to determine whether vacuum as specified in the Air Corps Technical Order for the particular instrument is being obtained.

d. Maintenance.—(1) Consult the Technical Order for the portable vacuum pump to obtain information concerning the grade of oil to use under various operating conditions.

(2) Inspect the motor brushes for correct length, and check the commutator for cleanliness. Supply proper lubricant as needed to the motor.

(3) Maintain sufficient oil in the reservoir of the oil-air separator.

170. Portable oil pump assembly.—*a. Purpose and use.*—The portable oil pump provides a source of oil pressure when performing various inspections and adjustments on the hydraulic system of the automatic pilot. The pump makes ground operation of the aircraft engine unnecessary.

b. Description.—The pump assembly (fig. 148) consists of a single phase, 110-volt, 60-cycle motor ($\frac{1}{3}$ -hp), coupled to a vane type oil

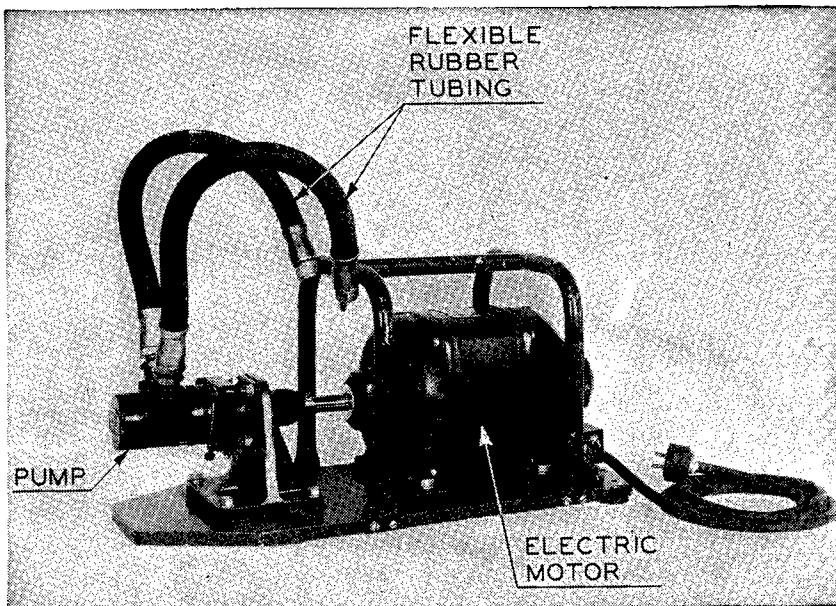

FIGURE 148.—Portable oil pump.

pump. Two flexible sections of rubber tubing are provided for unnecessary connections.

c. Application.—(1) When inspecting the hydraulic system of an automatic pilot in an aircraft installation, disconnect the hydraulic line connections at the hydraulic power pump and substitute the portable oil pump for the power pump. Care must be exercised to connect the pressure side of the portable oil pump to the pressure side of the hydraulic system.

(2) The unit should be securely mounted on a suitable stand.

d. Maintenance.—(1) The pump is self-lubricating and requires no periodic maintenance.

(2) Inspect the motor brushes for correct length, and the commutator for cleanliness. Supply proper lubricant as needed to the motor bearings.

INDEX

	Paragraph	Page
Accelerometers	148	168
Air speed indicators:		
Description	107	105
Installation	109	108
Maintenance	110	108
Operation	108	106
Purpose and use	106	104
Air speed tubes:		
Description	112	109
Installation	114	112
Maintenance	115	112
Operation	113	112
Purpose and use	111	109
Aircraft compasses (magnetic):		
Description	102	94
Installation	104	100
Maintenance	105	100
Operation	103	95
Purpose and use	101	94
Altimeters:		
Description	117	114
Installation	119	118
Maintenance	120	118
Operation	118	117
Purpose and use	116	113
Ammeters	160	207
Analysis cell test box (SAAD-E-70)	165	219
Automatic pilot, type A-2:		
Description	142	150
Installation	144	162
Maintenance	145	162
Operation	143	158
Purpose and use	141	150
Bank and turn indicators:		
Description	127	127
Installation	129	130
Maintenance	130	131
Operation	128	128
Purpose and use	126	126
Characteristics, design	2	2
Chronometric tachometers:		
Description	46	34
Installation	49	37
Maintenance	50	38
Operation	48	36
Purpose and use	46	34

INDEX

	Paragraph	Page
Clocks.....	146	163
Compasses, aircraft (magnetic).....	101-105	94
Cylinder temperature gages:		
Description.....	77	62
Installation.....	79	64
Maintenance.....	80	65
Operation.....	78	63
Purpose and use.....	76	62
De-icing pressure gages:		
Description.....	27	27
Installation.....	29	28
Maintenance.....	30	28
Operation.....	28	27
Purpose and use.....	26	26
Dead weight tester.....	158	201
Decade box.....	163	215
Design characteristics.....	2	2
Directional gyro turn indicators.....	131-135	132
Driftmeters.....	147	165
Electrically operated thermometers. (See Thermometers.)		
Engine gage unit:		
Description.....	42	33
Installation.....	44	33
Maintenance.....	45	34
Operation.....	43	33
Purpose and use.....	41	33
Engine synchronism indicator (Weston):		
Description.....	57	42
Installation.....	59	44
Maintenance.....	60	45
Operation.....	58	43
Purpose and use.....	56	42
Engine synchroscope (Eclipse):		
Description.....	62	46
Installation.....	64	47
Maintenance.....	65	48
Operation.....	63	46
Purpose and use.....	61	46
Flight indicators:		
Description.....	137	143
Installation.....	139	147
Maintenance.....	140	148
Operation.....	138	145
Purpose and use.....	136	142
Fuel level gages:		
Description.....	97	86
Installation.....	99	91
Maintenance.....	100	92
Operation.....	98	91
Purpose and use.....	96	86

TM 1-413

INDEX

	Paragraph	Page
Fuel mixture indicators:		
Description.....	82	65
Installation.....	84	70
Maintenance.....	85	72
Operation.....	83	68
Purpose and use.....	81	65
Fuel pressure gages:		
Description.....	12	19
Installation.....	14	20
Maintenance.....	15	20
Operation.....	13	19
Purpose and use.....	11	17
Gages:		
Cylinder temperature.....	76-80	62
Engine gage unit.....	41-45	33
Fuel level.....	96-100	86
Pressure:		
De-icing.....	26-30	26
Fuel.....	11-15	17
Landing gear.....	36-40	31
Manifold.....	21-25	23
Oil.....	31-35	29
Suction.....	16-20	21
Generator voltmeter tachometers:		
Description.....	52	39
Installation.....	54	41
Maintenance.....	55	42
Operation.....	53	40
Purpose and use.....	51	39
Importance of aircraft instruments.....	1	2
Indicators:		
Air speed.....	106-115	104
Altitude.....	116-120	113
Bank and turn.....	126-130	126
Engine synchronism (Weston).....	56-60	42
Engine synchroscope (Eclipse).....	61-65	46
Flight.....	136-140	142
Fuel mixture.....	81-85	65
Rate of climb.....	121-125	121
Self-synchronous.....	86-90	73
Selsyn.....	91-95	82
Turn (directional gyro).....	131-135	132
Inspection.....	3, 7	8, 13
Installation.....	8-10	14
Liquidometers.....	96-100	86
Magnetic compasses.....	101-105	94
Maintenance.....	3-7	8

INDEX

	Paragrap	Page
Manifold pressure gages:		
Description.....	22	24
Installation.....	24	25
Maintenance.....	25	25
Operation.....	23	24
Purpose and use.....	21	23-
Manometer.....	156	195
Mounting panels and connections.....	9	14
Ohmmeters.....	161	208
Oil pressure gages:		
Description.....	32	29
Installation.....	34	31
Maintenance.....	35	31
Operation.....	33	30
Purpose and use.....	31	29
Oil pump assembly, portable.....	170	226
Packing.....	6	12
Panels, mounting.....	9	14
Portable equipment:		
Instrument field test set.....	149-154	169
Oil pump assembly.....	170	226
Vacuum pump assembly.....	169	225
Rate of climb indicators:		
Description.....	122	121
Installation.....	124	124
Maintenance.....	125	125
Operation.....	123	124
Purpose and use.....	121	121
Reinspection.....	7	13
Removal.....	4	10
Repairs, common.....	5	10
Replacement.....	4	10
Self-synchronous instruments:		
Description.....	87	74
Installation.....	89	78
Maintenance.....	90	81
Operation.....	88	78
Purpose and use.....	86	73
Tachometers:		
Chronometric.....	46-50	34
Generator voltmeter.....	51-55	39
Test stand.....	166	221
Test equipment:		
Ammeters.....	160	207
Analysis cell test box.....	165	219
Classes.....	149, 155	169, 195
Dead weight tester.....	158	201
Decade box.....	163	215
General.....	149, 155	169, 195
Gyroscopic instrument test fixture.....	168	213

INDEX

	Paragraph	Page
Test equipment—Continued.		
Manometer.....	156	195
Ohmmeters.....	161	208
Portable oil pump assembly.....	170	226
Portable vacuum pump assembly.....	169	224
Portable:		
Oil pump assembly.....	170	226
Type C-1, field set:		
Application.....	153	180
Description.....	151	169
Inspection.....	154	193
Maintenance.....	154	193
Operation.....	152	179
Purpose and use.....	150	167
Vacuum pump assembly.....	169	225
Tachometer test stand.....	166	221
Thwing potentiometer.....	162	212
Turntable assembly.....	167	222
Vacuum chamber.....	157	200
Vapor pressure thermometer tester.....	164	215
Voltmeters.....	159	203
Thermometers:		
Cylinder temperature gage.....	76-80	62
Electrically operated:		
Description.....	72	53
Installation.....	74	60
Maintenance.....	75	61
Operation.....	73	56
Purpose and use.....	71	53
Vapor pressure:		
Description.....	67	50
Installation.....	69	52
Maintenance.....	70	53
Operation.....	68	50
Purpose and use.....	66	48
Tester.....	164	215
Thwing potentiometer.....	162	212
Time limit, storage.....	7	13
Timepieces.....	146	163
Turn indicators (directional gyro):		
Description.....	132	133
Installation.....	134	138
Maintenance.....	135	140
Operation.....	133	136
Purpose and use.....	131	132
Turntable assembly.....	167	222
Vacuum chamber.....	157	200
Vacuum pump assembly, portable.....	169	225
Vapor pressure thermometer. (See Thermometers.)		
Weston engine synchronism indicator.....	56-60	42

TM 1-413

INDEX

[A. G. 062.11 (9-2-41) (11-4-41).]

BY ORDER OF THE SECRETARY OF WAR:

G. C. MARSHALL,
Chief of Staff.

OFFICIAL:

E. S. ADAMS,
*Major General,
The Adjutant General.*

DISTRIBUTION:

Bn and H 1 (6); IBn 1 (10); Bn 9 (2); IC 9 (3).
(For explanation of symbols see FM 21-6.)