

Electric Sit-Stand Workstation

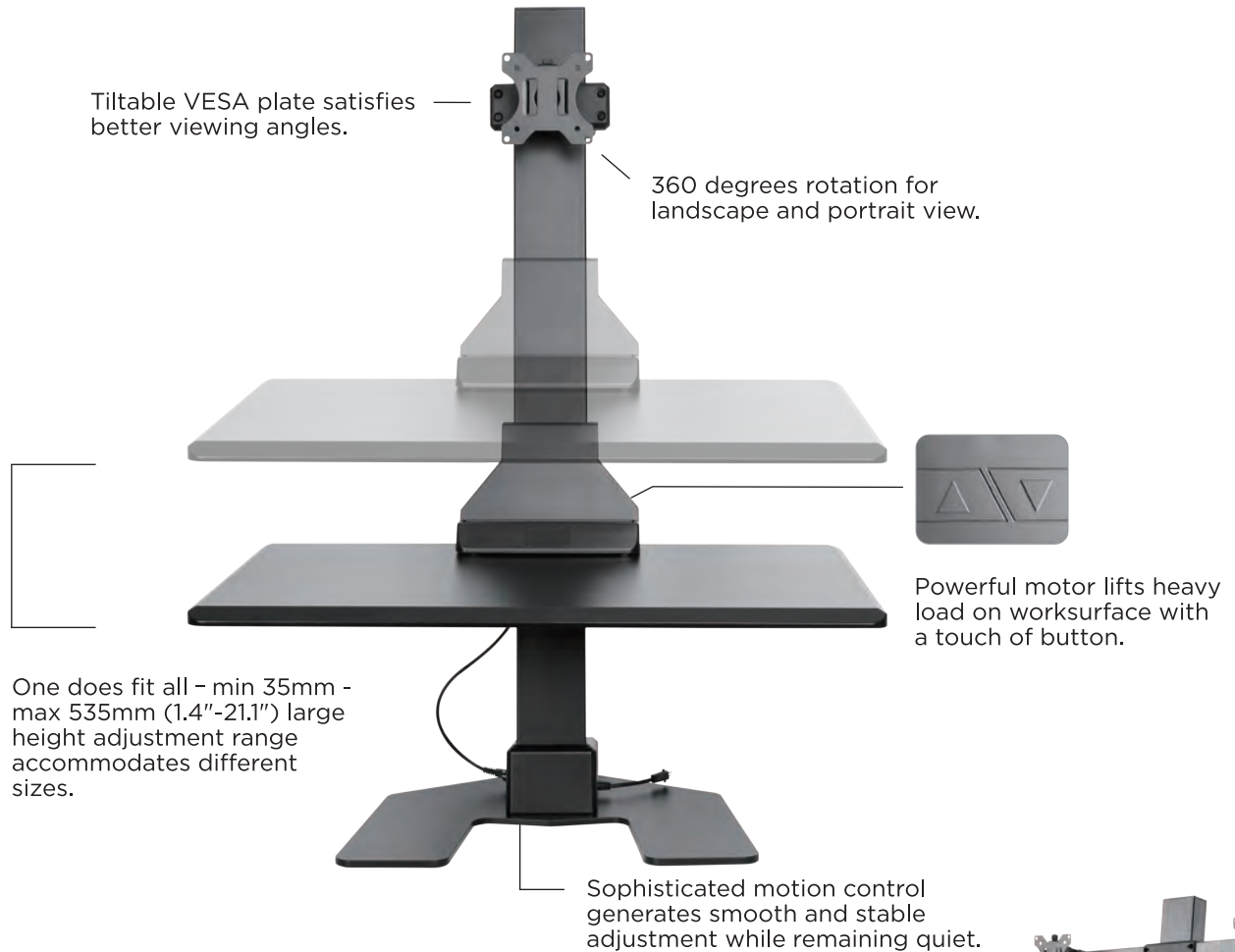

Great Synthesis of Technical, Ergonomic & Aesthetic Design

Color: 



Integrated Cable Management



Worksurface Organizer



SE05E2WB
Dual Monitor Application

Electric Sit-Stand Workstation



SEO4E1WB

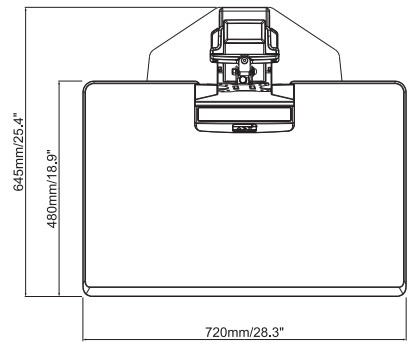
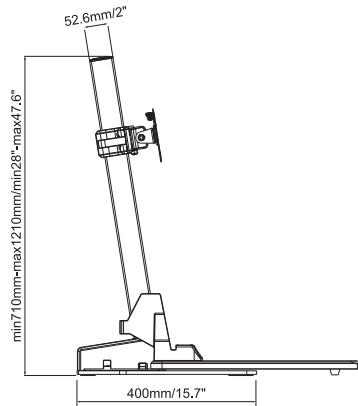
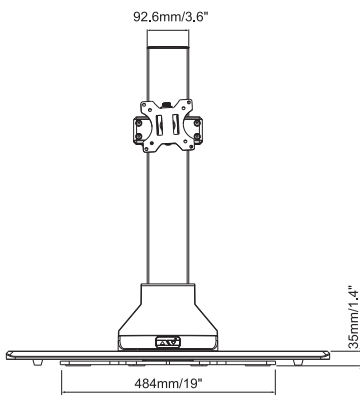

SEO5E2WB

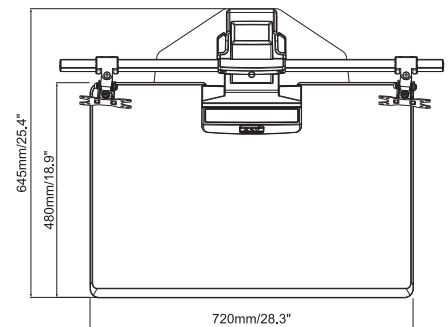
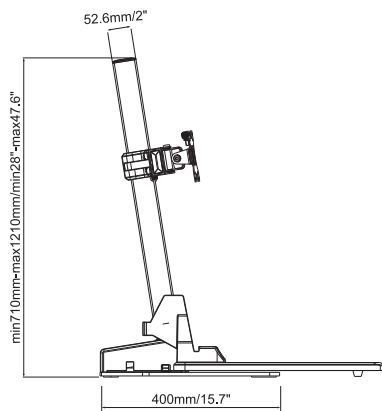
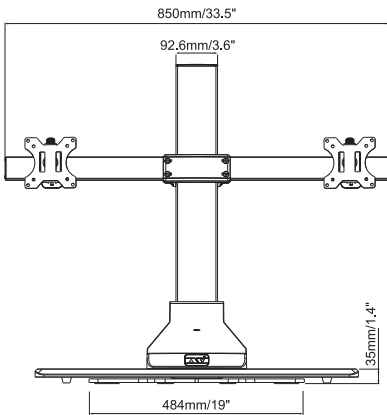

Specifications	SEO4E1WB	SEO5E2WB
Worksurface Height Adjustable Range:	500mm (19.7")	500mm (19.7")
Worksurface Size:	720x480mm (28.3"x19")	720x480mm (28.3"x19")
Monitor Qty:	1	2
Typical Screen Size:	13"-32"	13"-32"
Tilt:	+45° ~ -45°	+45° ~ -45°
Pivot:	+30° ~ -30°	+30° ~ -30°
Rotation:	360°	360°
Weight Capacity:	20kg	20kg
Material:	Steel, Plastic & Wood	Steel, Plastic & Wood
VESA:	75x75mm/100x100mm	75x75mm/100x100mm
Input:	100V-240V	100V-240V
Motor Type:	Tube Motor	Tube Motor
Control Type:	Button	Button
Maximum Adjustment Speed:	25mm/s	25mm/s
Available Color:	Black & White	Black & White