

# haubold®

## **RNC45R** *Operating Instructions*

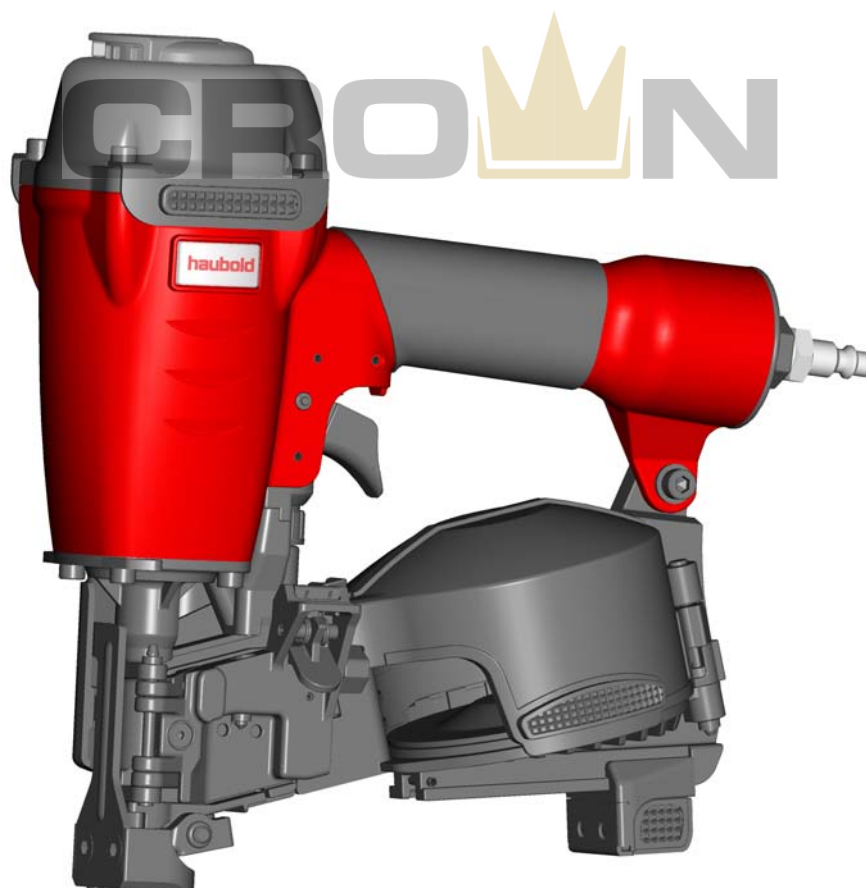

D: Bedienungsanleitung  
NL: Gebruiksaanwijzing  
F: Manuel d'utilisation  
E: Instrucciones de uso  
P: Manual de Instruções  
I: Istruzioni d'uso  
DK: Brugsanvisning  
S: Bruksanvisning

N: Bruksanvisning  
FIN: Käyttöohjeet  
EE: Kasutusjuhend  
PL: Instrukcja obsługi  
CZ: Návod k obsluze  
H: Használati utasítás  
SLO: Navodila za uporabo  
HR: Upute za rukovanje

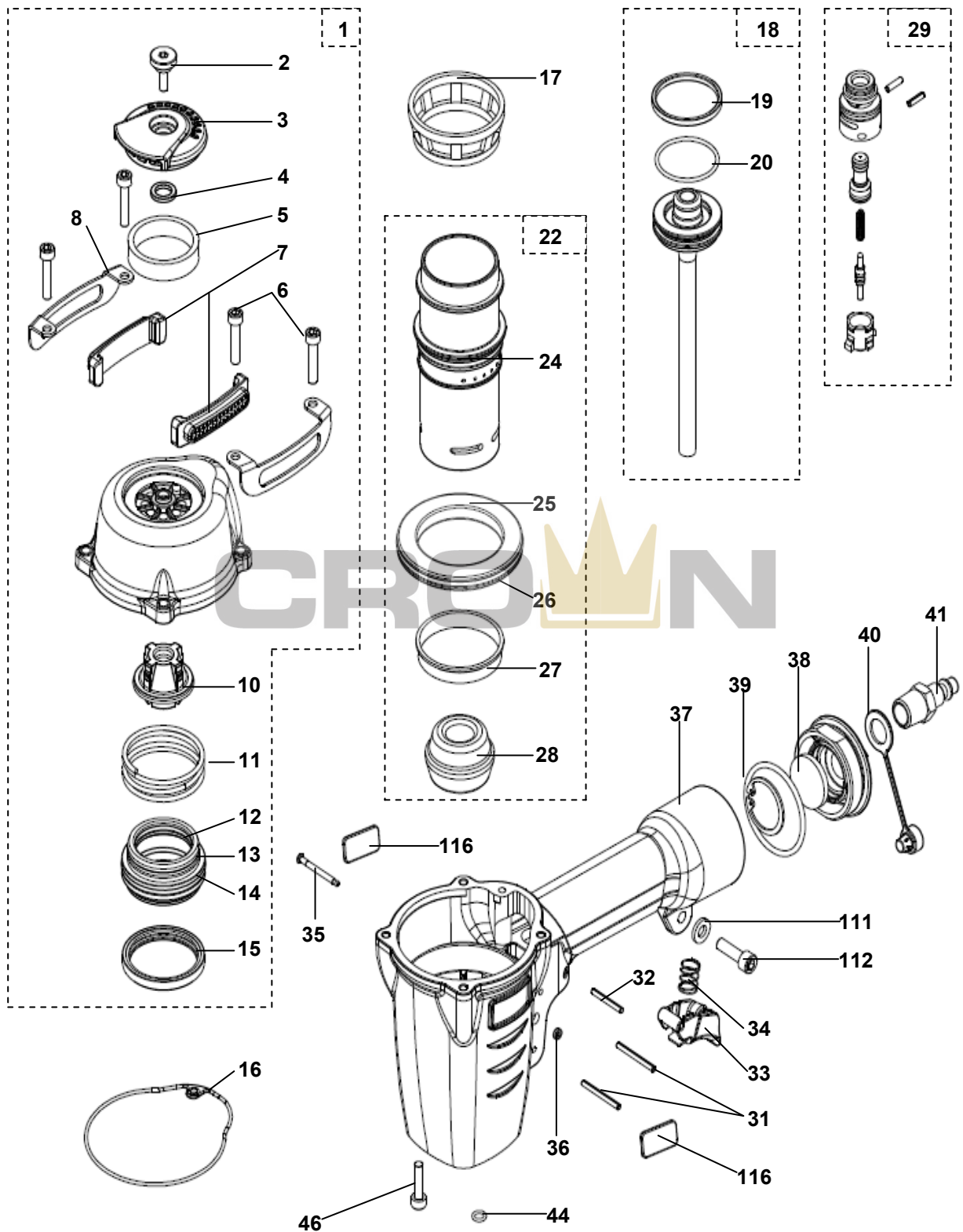



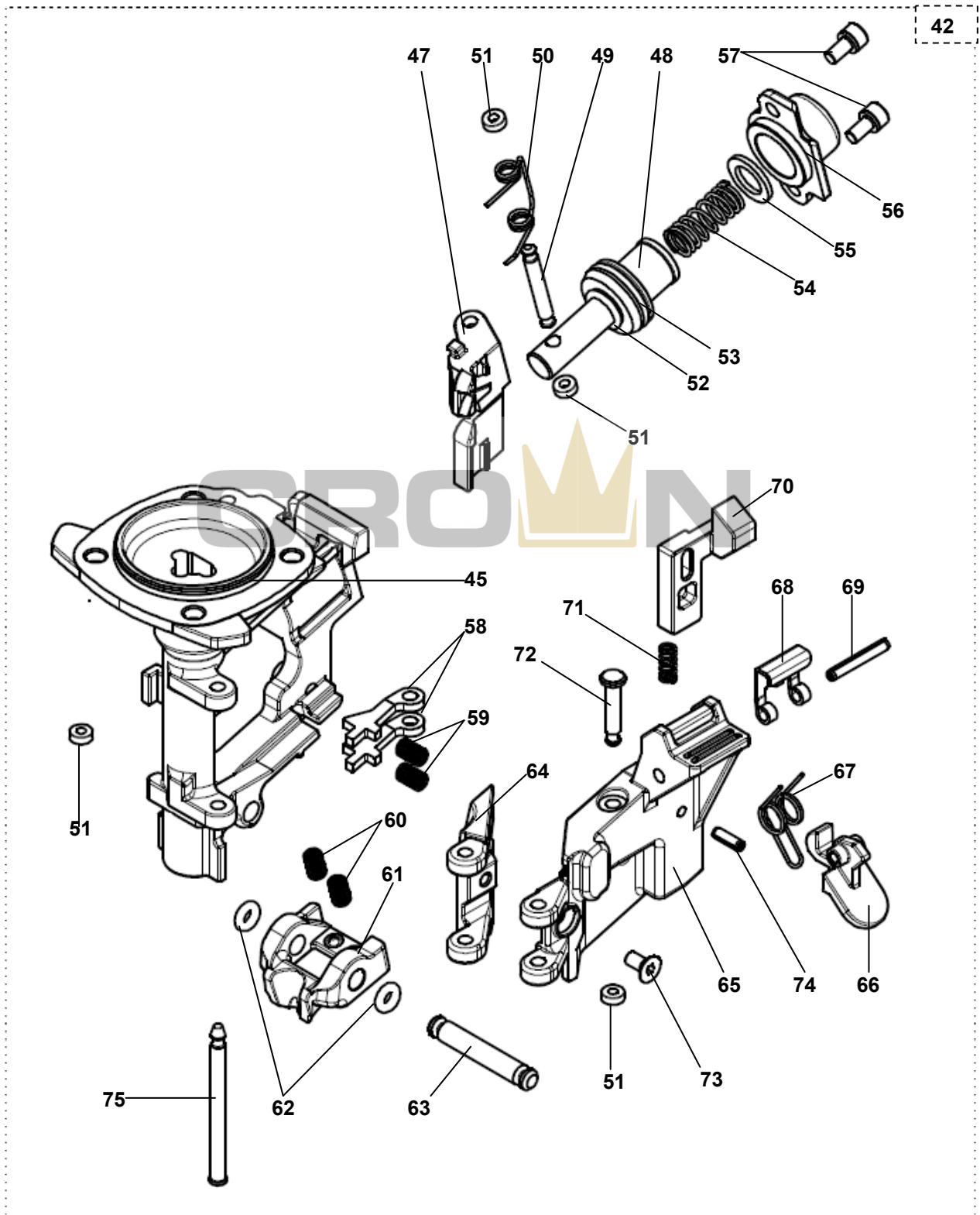

NO.	EURO CODE	DESCRIPTION	NO.	EURO CODE	DESCRIPTION
1	613802	CAP ASSEMBLY	63	613299	FIXED PIN
2	613205	DEFLECTOR BOLT(3M2353)	64	613837	GUIDE BLOCK
3	613301	DEFLECTOR	65	613838	DOOR
4	613207	RUBBER PAD	66	613839	DOOR LATCH
5	613803	MUFFLER	67	613840	LATCH SPRING
6	613338	HEX.SOC.HD.BOLT	68	613841	POSITIONING SHEET
7	613804	PROTECTIVE CUSHION	69	613842	SPIRAL PINS
8	613805	GUIDE COVER	70	613843	STOPPER
10	613807	SEAL	71	613263	STOPPER FINGER SPRING
11	613808	COMPRESSION SPRING	72	613844	FIXED PIN
12	613809	O - RING	73	613845	COUNTER SUNK SCREW
13	613810	HD.VALVE PISTON	74	613846	SPIRAL PINS
14	613811	O - RING	75	613266	DOOR SHAFT PIN
15	613812	COLLAR	76	613847	SAFETY GUIDE
16	613813	PACKING	77	613797	SPRING PIN
17	613218	CYLINDER PRESS RING	78	613798	SAFETY SPRING
18	613814	DRIVER ASSEMBLY	79	613848	SAFETY B UNIT
19	613815	PISTON RING	80	613849	ADJUST AXIE
20	613816	O - RING	81	613850	SAFETY COVER
22	613818	CYLINDER ASSEMBLY	82	613851	SAFETY ASSEMBLY
24	613820	O - RING	83	613852	ADJUST ROD
25	613821	CYLINDER SPACER	84	613247	O - RING
26	613822	O - RING	85	613853	SAFETY
27	613793	CYLINDER RING	86	571584	E - RING
28	613823	BUMPER	87	613854	SAFETY A UNIT
29	613736	TRIGGER VALVE ASSEMBLY	88	613855	COUNTER SUNK SCREW
31	613237	SPRING PIN	89	613856	MAGAZINE PROTECTIVE CUSHION
32	613824	SPRING PIN	90	613857	MAGAZINE CASE
33	613887	TRIGGER UNIT (CONTACT)	91	613287	LOCK NUT
33	613825	TRIGGER UNIT (SEQUENTIAL)	92	613858	MAGAZINE SHAFT PIN
34	613242	SPRING	93	613859	PU RETAINER
35	613240	TRIGGER PIVOT PIN	94	613860	MAGAZINE COVER
36	501089	URETHANE RETAINER	95	613861	FIXED SUPPORT
37	613826	GUN BODY UNIT	96	613862	MAGAEING POST
38	613827	END CAP	97	613863	SPRING
39	613244	O - RING	98	613864	PIN
40	571563	DUSTY COVER	99	613865	NAIL BRACKET
41	574360	AIR PLUG	100	613866	ADJUST ROD
42	613828	NOSE ASSEMBLY	101	613867	SPACER
44	613830	O - RING	102	613282	TAP BOLT
45	613248	O - RING	103	613868	POSITIONING SHEET
46	613831	HEX.SOC.HD.BOLT	104	613869	SAFETY SPRING
47	613249	FEED FINGER	105	613870	ADJUSTING PLATE-A
48	613250	FEED PISTON	106	613871	ADJUSTING PLATE-B
49	613251	PIN FEED PISTON	107	633040	SPRING PIN
50	613252	FEED FINGER SPRING	108	574368	HEX.SOC.HD.BOLT
51	613253	PU RETAINER	109	613724	FLAT WASHER
52	613254	O - RING	110	613872	SAFETY COVER
53	613255	O - RING	111	613873	FLAT WASHER
54	613256	FEED PISTON SPRING	112	613874	HEX.SOC.HD.BOLT
55	613257	FEED-BUMPER	113	613875	PIN
56	613832	FEED PISTON CAP	114	613876	O - RING
57	613833	BOLT ASSY	115	613877	SPRING
58	613834	NAIL STOP	116	613879	LOGO LABEL
59	613262	SPRING	117	505918	MODEL LABEL (CONTACT)
60	613835	GUIDE BLOCK SPRING	117	505919	MODEL LABEL (SEQUENTIAL)
61	613836	GUIDE BLOCK	118	613881	WARNING LABEL
62	613300	O - RING	120	613878	TRAY (MAGAZINE INSERT)

