

SERIES: C-Ring Closure Tools

TOOL MODELS: **RAC-1001** (3/4"), **RAC-1002** (3/4" Tight Closure), **RAC-1004** (3/4" Extended Nose)
RAC-1003 (1/2")

PRODUCT #: RAC-1001, RAC-1002, RAC-1004, RAC-1003

	Tool Number	Item Number	Description	Qty		Tool Number	Item Number	Description	Qty		
1		EHC01001	Set Screw	1	49		EHC01049	Roller Pin	2		
3		EHC01003	Lock Washer	7	50	1001	EHC04050	Lower Jaw	1		
4		EHC01004	Air Deflector	1		1002	EHC02050				
5		EHC01005	Rear Valve Seat	1		1003	EHC01050				
6		EHC01006	O-Ring	2		1004	EHC05050				
7		EHC01007	Throttle Spring	1	51		EHC01M051	Feeder Arm	1		
8		EHC01008	Throttle Spring Locator	1	52		EHC01M052	Washer	2		
9		EHC01009	Throttle Valve Screw	2	55L		EHC01M55L	Feeder Guide Rail	1		
10		EHC01010	Valve Screw Washer	2	56		EHC01056	Washer	2		
11		EHC01011	O-Ring Support	4	57		EHC01057	Nut	2		
12		EHC01012	O-Ring	5	58		EHC01M058	Screw	2		
13		EHC01013	O-Ring Center Support	2	64		EHC01M064	Socket Head Cap Screw	1		
14		EHC01014	Throttle Valve Spacer	1	67		EHC01M067	Magazine Set	1		
16		EHC01016	Front Valve Seat	1	68	1001/1002/1004	EHC02M068	Pusher	1		
17		EHC01017	Throttle Stem	1		1003	EHC01M068				
18		EHC01018	Button Head Cap Screw	1	69		EHC01M069	Stop Ring	2		
20		EHC01020	Trigger Guard	1	71		EHC01071	Feeder Arm Screw	1		
21		EHC01021	Nyloc Nut	2	73	1001/1002/1004	EHC02M073	Magazine Body	1		
23		EHC01023	Stud	2		1003	EHC11M073				
27		EHC01027	Housing	1	74		EHC01074	Jaw Bolt	2		
28		EHC01028	Set Screw	2	75	1001/1002/1004	EHC02075	Magazine Spring	2		
29		EHC01029	O-Ring	1		1003	EHC01075				
30		EHC01030	Piston	1	76	1001/1002/1004	EHC02M076	Magazine Shoe	1		
31		EHC01031	Cylinder Gasket	1		1003	EHC01M076				
32	1001/1003	EHC01032	Piston Stop Spacer	1	77	1001/1002/1004	EHC02077	Roll Pin	1		
	1002/1004	EHC02032					1003			EHC01077	
35R		EHC0135R	Side Plate (Right)	1	78		EHC01078	Magazine Shim (thick)	1		
35L		EHC0135L	Side Plate (Left)	1	78A		EHC01078A	Magazine Shim	1		
36		EHC01036	Roll Pin	3	79		EHC01079	Washer	2		
37		EHC01037	Trigger	1	82		EHC02082	Anti-Backup Clip	1		
39		EHC01039	Socket Head Cap Screw	4	83		EHC01M083	Screw	1		
40	1001	EHC04040	Upper Jaw	1	86		EHC01086	Screw	1		
	1002	EHC02040					89		EHC01089	Nyloc Nut	3
	1003	EHC01040					94		EHC01M094	Pin	2
	1004	EHC05040					97		EHC1M097	Spring Roller	1
41		EHC01041	Jaw Bushing	2							
43		EHC01043	Latch Pin Clip	1							
44	1001/1002/1003	EHC01044	Latch Spring	1	ASSEMBLIES						
	1004	EHC05044				200		EHC01200	Housing Assembly	1	
45	1001	EHC03045	Latch	1	201	1001	EHC03201	Piston & Piston Rod Assembly	1		
	1002/1003	EHC01045					1002			EHC02201	
	1004	EHC05045					1003			EHC01201	
							1004			EHC05201	
46	1001/1003/1004	EHC01046	Roller	4	202	1001	EHC03202	Piston Rod Assembly	1		
	1002	EHC02046								1002	EHC02202
47	1001	EHC03047	Feeder Blade	1		1003	EHC01202				
	1002	EHC02047								1004	EHC05202
	1003	EHC01047					203		EHC01203	Frame Assembly	1
	1004	EHC05047					205	1001/1002/1004	EHC02M205	Pusher Assembly	1
48	1001/1004	EHC03048	Piston Rod	1		1003	EHC01M205				
	1002	EHC02048					206	1001/1002/1004	EHC02M206	Magazine Assembly	1
	1003	EHC01048						1003	EHC11M206		
					208		EHC01208	Throttle Assembly	1		
					210		EHC01M210	Spring Assembly	1		



C-RING TOOL

RAC-1001 (3/4"), **RAC-1002** (3/4" Tight Closure),
RAC-1003 (1/2"), **RAC-1004** (3/4" Ext Nose)

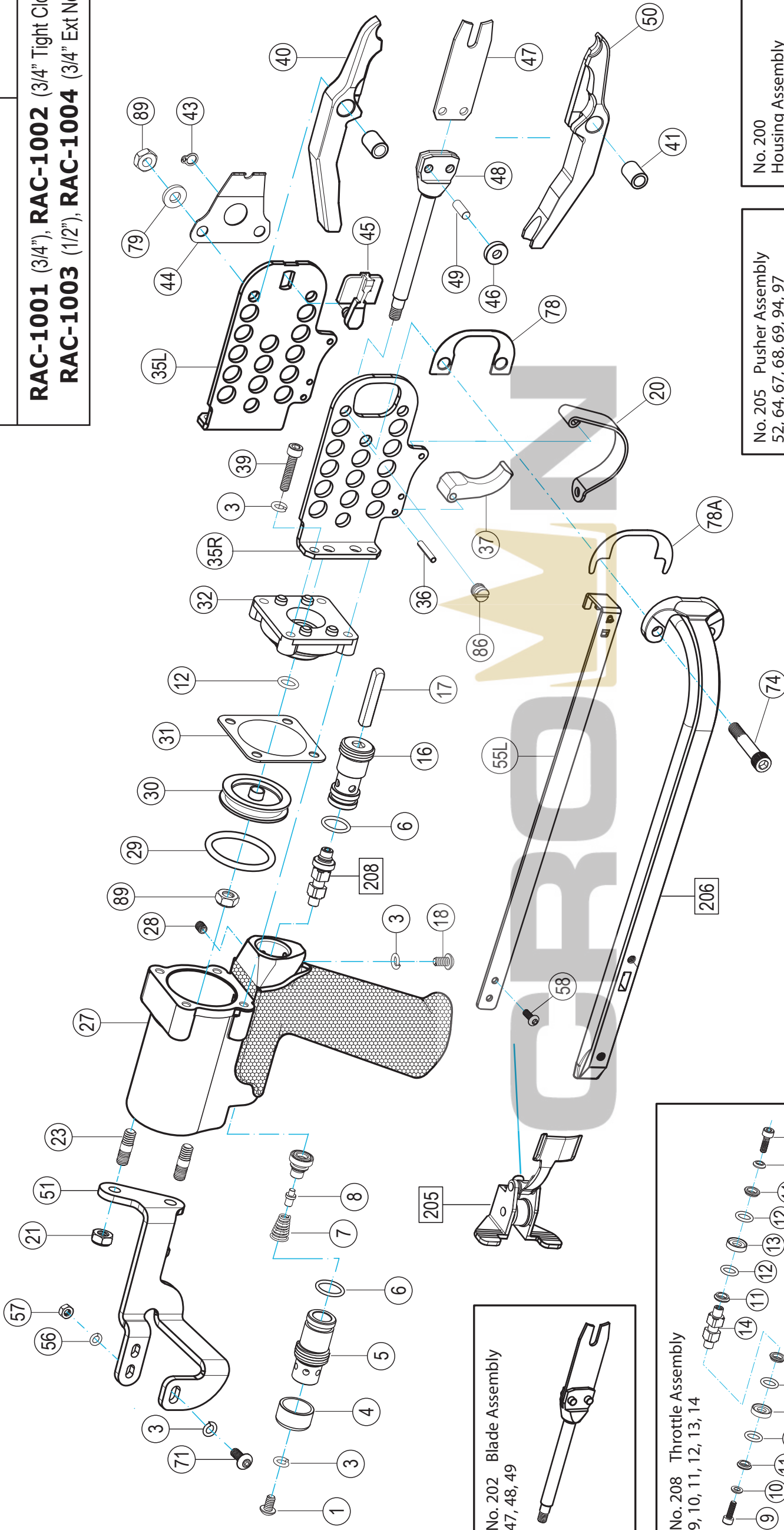

No. 202 Blade Assembly
47, 48, 49

No. 208 Throttle Assembly
9, 10, 11, 12, 13, 14

No. 201 Piston & Piston Rod Assembly
12, 29, 30, 31, 32, 47, 48, 49, 89

No. 203 Frame Assembly
20, 35R, 35L, 36, 37, 86

No. 206 Magazine Assembly
73, 75, 76, 77, 82, 83

No. 205 Pusher Assembly
52, 64, 67, 68, 69, 94, 97

No. 200 Housing Assembly
23, 27, 28