

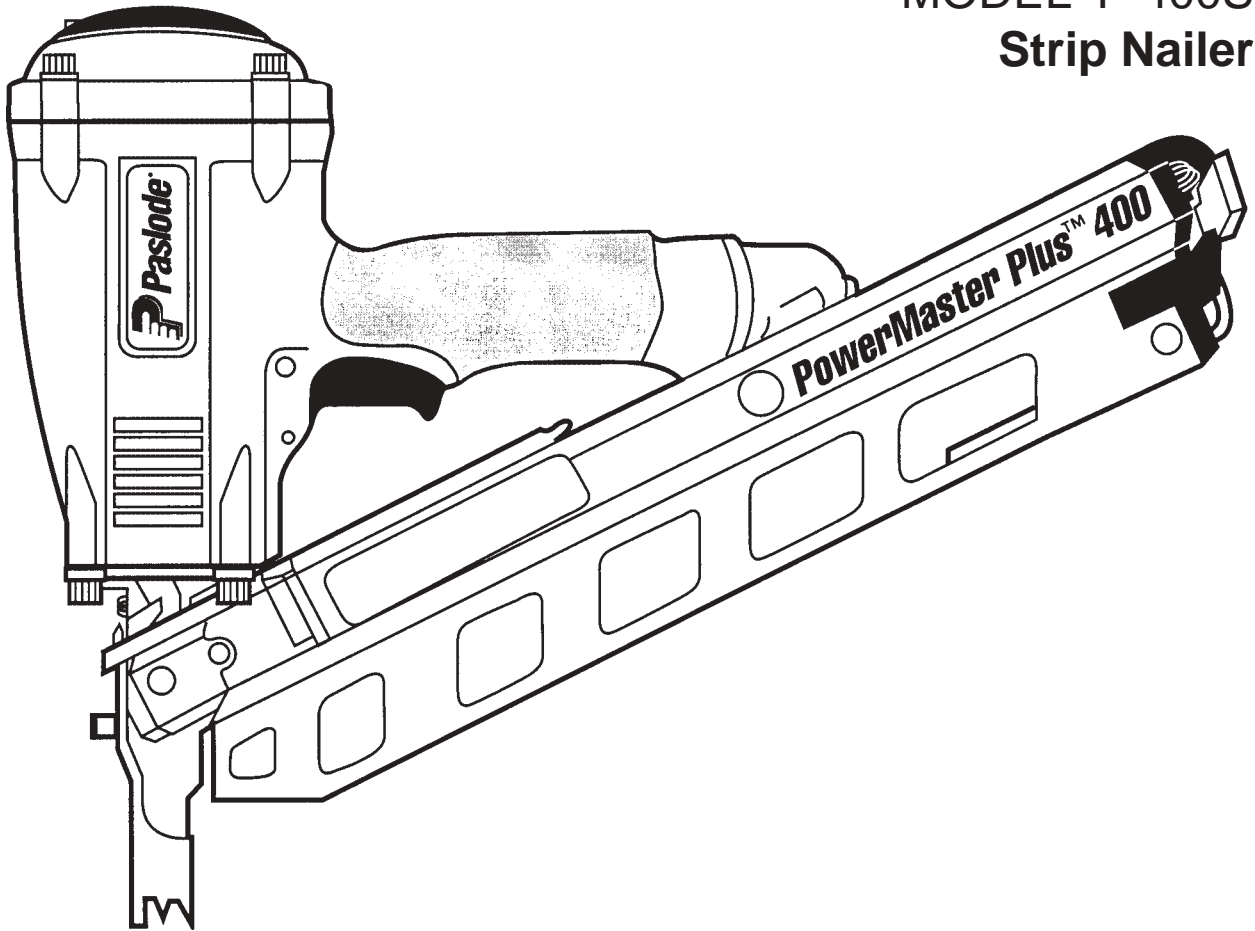

PowerMaster Plus™ 400
MODEL F-400S
Strip Nailer



PowerMaster Plus™ 400

**IMPORTANT!
DO NOT DESTROY**

Always refer to safety and maintenance manuals #405218 and #405219 for detailed information on this tool. It is the customers responsibility to have all operators and service personnel read and understand this information.

**TOOL SCHEMATIC AND
PARTS**

www.crownpartsglobal.com

PARTS LEGEND *PowerMaster Plus*TM F-400S, 500705

▲ 1	501043	1	T.H.S.C.S. 1/4 -20 x 1/2"	39	402668	1	Retaining Ring
2	501016	1	Air Deflector	40	097748	1	Spring, Valve Pin
3	091873	4	S.H.C.S. 1/4-20 x 2"	41	097746	1	Valve Pin
4	092757	4	Flatwasher 1/4"	42	071297	3	Roll Pin 1/8 x 1-1/8"
5	500707	1	Cap	*43	092174	1	O-Ring, Valve Body
*6	500461	1	O-Ring	44	401958	1	Valve Body
*7	092042	1	O-Ring	46	500712	1	Nose 30°
8	500407	1	Spring, Main Valve	47	095417	4	Lockwasher 5/16
*9	501001	1	Gasket, Cap	▲48	009016	4	S.H.C.S. 5/16-18 x 1"
10	406041	1	Retaining Ring	49	501006	1	Spring, W.C.E.
11	500455	1	Upper Valve Piston	50	500734	1	Upper W.C.E.
12	401946	1	Seal, Main Valve	51	091618	1	S.H.C.S. 1/4-20 x 1/2"
*13	091208	1	O-Ring	52	500713	1	Lower W.C.E.
*14	401950	1	O-Ring	53	500841	1	Magazine with Wear Strips
15	500456	1	Lower Valve Piston	54	500717	1	Nail Cover
16	500454	1	Post	55	500531	1	Follower
*17	095432	2	O-Ring	56	501044	1	3/16 Hex Key, Long Arm
18	500453	1	Bumper, Post	57	501024	1	End Cap, Magazine-LF
19	402906	1	B.H.S.C.S.10-32 x 5/8"	58	501025	1	End Cap, Magazine-RT
*20	092971	1	O-Ring, Piston	59	501027	1	Latch
*21	500709	1	Piston Assembly	60	501046	1	Drum Pin Assembly
22	402011	1	Seal Sleeve	61	500513	1	Negator Assembly
23	500710	1	Sleeve	62	500839	1	Nameplate
*24	092235	1	O-Ring, Sleeve	▲63	404904	2	Screw 1/4-28 x 5/8"
*25	501002	1	O-Ring	64	500509	1	Front Bracket
*26	500866	1	Bumper	65	501028	1	Spring, Latch
27	501020	1	Housing	66	501026	1	S.H.C.S. 8-32 x 2"
28	501023	1	Grip, Handle	67	066840	1	S.H.C.S. 8-32 x 3/4"
→ 29	501033	1	Label, Housing-Leftside	68	404414	2	Flatwasher #8
	501034	1	Label, Housing-Rightside	69	404325	2	Stop Nut
30	501013	1	End Cap, Housing	70	500520	2	Wear Strip
31	500516	1	B.H.S.C.S. - Special	** 71	500458	1	Warning Label
32	404274	1	Flatwasher	72	500838	2	Logo Label
33	500525	1	Locknut, 5/16-24	73	500199	1	Spring, Trigger
34	091622	1	Reducing Pipe Bushing	74	500729	1	Blade Seal
35	501010	1	Trigger	75	500779	1	Flange, Sleeve
36	402669	1	Pin, Trigger	76	500249	1	O-Ring, Sleeve
37	501009	1	Spirol Pin	77	002187	1	Lock Washer
38	501008	1	Lever, Bottom Trip	78	404800	1	Flat Washer

* Denotes Normal Wear Items

** Make sure Warning Label (Part No. 500458) is properly affixed. Replace if necessary. Label available at no charge through the Service Department.

▲ Apply Loctite 242 (Blue) Part No. 093500

! WARNING

All parts must be periodically inspected and replaced if worn or broken. Failure to do this can affect the tool's operation and present a safety hazard.

Air Consumption Chart

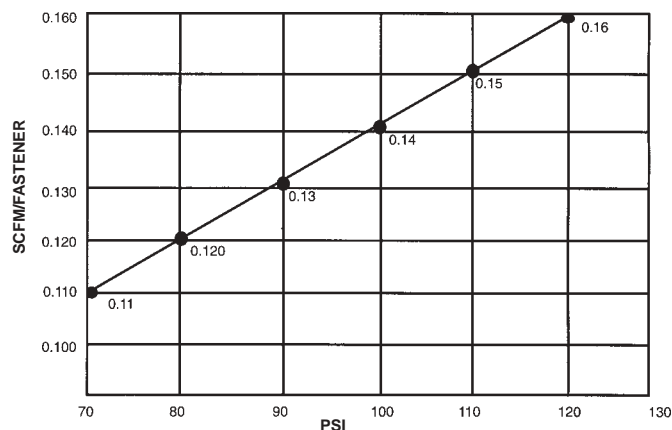

PowerMaster Plus™ 400

F-400S

500705

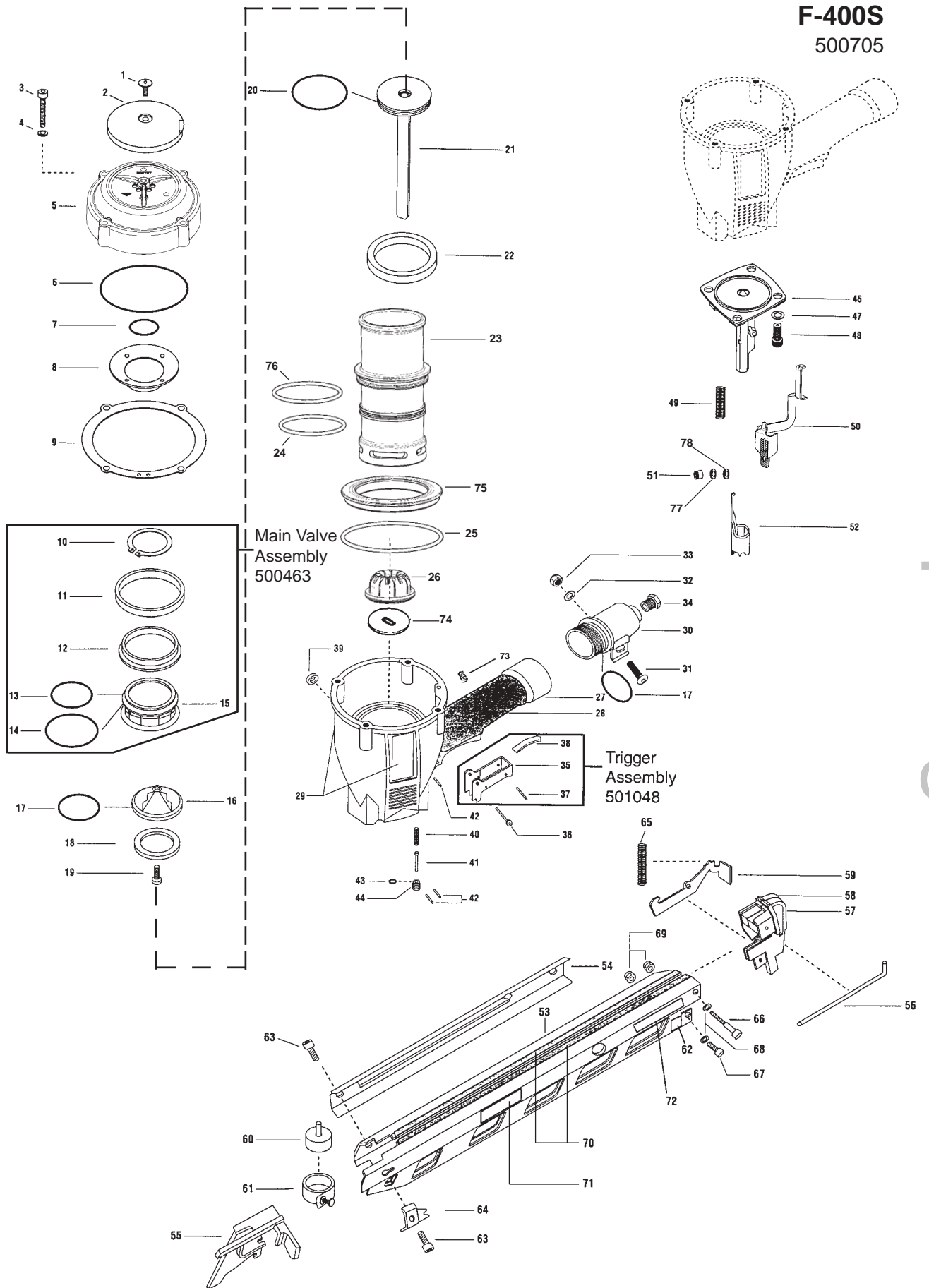

ACCESSORIES

Sequential Operating Kit

This special attachment is designed for sequential operation (stops "contact" firing). The operator must depress and hold the work contacting element against the work surface before pulling the trigger. This sequence must be repeated each time the tool drives a fastener.

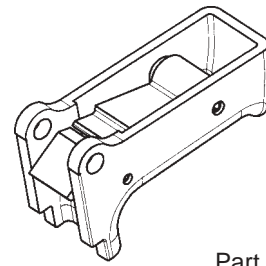

Part No.501039

Remote Fire Valve

This valve via a positive air signal allows a machine mounted tool to be operated from an automatic air valve or foot pedal system.

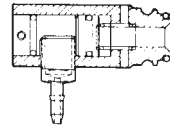

Part No. 1X0713

Trigger Valve Kit

Repairs trigger valve air leaks.

Part No. 219224

No-Mar Work Contacting Element

W.C.E. with a rubber tip prevents you from marring wood surfaces.

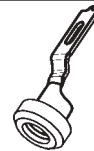

Part No.500903

No-Mar Tip

Replacement tip for No-Mar Work Contacting Element #500903.



Part No. 501022

Lubricants and Loctite

Loctite 242 (Blue)
Lubricating Oil 16 oz.
Lubricating Oil with Antifreeze
Chemplex 710 Lubricant 1 lb.
Lubricant 5 gram tube

Part No. 093500
Part No. 403720
Part No. 219090
Part No. 403734
Part No. 219188

Degreaser Cleaner

Ideal cleaner for all Paslode tools.

Part No. 219086

Safety Glasses

Clear
Tinted



Part No. 402510
Part No. 402512

SAFETY INSTRUCTIONS

WEAR EYE AND HEARING PROTECTION



Always wear hearing protection and eye protection devices, including side shields when operating or working in the vicinity of a tool.

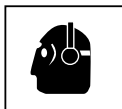

Never use any bottled air or gases such as oxygen to operate the tool since they could cause the tool to explode.

DO NOT EXCEED MAXIMUM RECOMMENDED AIR PRESSURE

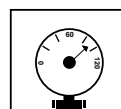
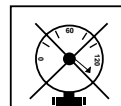

Operate the tool using only the recommended air pressure. Do not exceed the maximum air pressure marked on the tool. Be sure the air pressure gauge is operating properly and check it at least twice a day.



An Illinois Tool Works Company
888 Forest Edge Drive
Vernon Hills 60061-3105

www.grownpartsglobal.com