

Eclipser 2500/2800

and Continuous Coil (CC) Clipping System

OPERATING MANUAL

Encore Eclipser 2500 Series (Green)

Hartco Eclipser 2500 (Black) not shown



Hartco Eclipser 2800 Series (Black)



Encore Eclipser 2800 Series (Green)



MADE IN THE U.S.A.

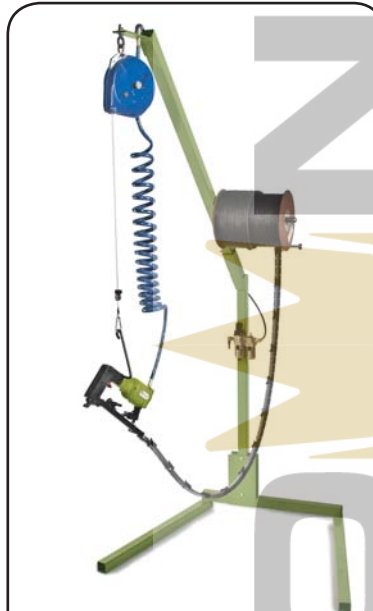

Encore Hartco Continuous Coil (CC) Clipping System

See pages 5-6

ENCORE (EA) ECLIPSER 2500 and 2800 SERIES

Pneumatic Clipping Tool
GREEN Housing

HARTCO (HR) ECLIPSER 2500 and 2800 SERIES

Pneumatic Clipping Tool
BLACK Housing

Compatible with Encore E-Clips, Hartco clips and other industry standard clips

SAFETY INFORMATION



READ THE ENTIRE MANUAL BEFORE OPERATING THE TOOL.



SAFETY GLASSES should always be worn while operating, maintaining or repairing a tool.



KEEP HANDS AND FINGERS AWAY from the blade and anvil area when operating or connecting air supply to tool.



DISCONNECT THE AIR SUPPLY when mechanically clearing a jam, performing maintenance or repairs, and whenever the tool is not in use.



Never use oxygen, carbon dioxide or any other bottled gas as a power source for this tool—the tool will explode and cause serious injury.



INJURY PREVENTION—Never point the tool toward yourself or anyone else.

encore
FASTENERS

HARTCO

... Innovating Legendary Products

The Eclipser 2500 / 2800 Series

30131 – HANGER ASSEMBLY (included)

- 15316 SCREW
- 55095 HANGER YOKE
- 20065 SCREW
- 20012 NUT
- 15037 BEARING
- 30130 HANGER
- 20037 E-CLIP
- 30033 HANGER PIN
- 20036 C-CLIP

BLADE JAM RELEASE COMPONENTS

- 20002 PLUG
- 20028 TUBE FITTING
- 30115 POLY TUBE 0.38" X 9.5"
- 20029 ELBOW
- 20025 TEE
- 20030 HEX NIPPLE
- 30113 SLIDE VALVE
- 20027 TUBE FITTING

2500 Series Only

20035 PLUG (RED)

2800 Series HOUSING

30120 (GREEN)
38120 (BLACK)

2500 Series not shown:
30002 (GREEN)
38002 (BLACK)

30118 WASHER
Only for 2800 tools

30014 TOP PLATE

30016 SPRING

30015 PIN

20010 PIN

20009 PIN

30012 SIDE PLATE R. H.

20008 BHCS

20012 NUT

30011 TRIGGER

30019 LINK

30010 LEVER

20018 PIN

30020 PIN, ROLLER

30009 VALVE SLEEVE

30022 FRONT PLATE

BLADE GUIDE
302

ANVIL
302

30013 SIDE PLATE, L. H.

30023 SHOULDER SCREW

20017 NUT

30106 SPRING

30107 ARM

20022 SCREW

BLADE
302

BRACKET
30104 or 30154

20000 O-RING

20001 O-RING

20003 O-RING

30000 VALVE

20026 FITTING

20011 SCREW

30001 CAP

20005 O-RING

30004 PISTON

20015 O-RING

30005 SPRING

20006 O-RING

20007 O-RING

30008 VALVE

30007 SPRING

30111 SPRING

20014 O-RING

30112 PIN

20023 SHCS

30117 BRACKET

30110 SPRING

30109 PISTON

COVER
30102 or 30152

20020 SHCS

30114 TUBE 2.5" X 3.75"

20026 FITTING

20013 O-RING

30108 CYLINDER

LINER STRIP
30101 or 30151

20021 NUT

20011 SHCS

30105 HUB

30103 WHEEL

20016 BEARING

MAGAZINE
30100 or 30150

20020 SHCS



2500/2800 UNIVERSAL PARTS

Item #	Description	Qty	Item #	Description	Qty
20000	O-Ring	1	30103	Wheel	1
20001	O-Ring	1	30105	Hub	1
20002	Plug	1	30106	Spring	1
20003	O-Ring	1	30107	Arm	1
20004	O-Ring	1	30108	Cylinder	1
20005	O-Ring	1	30109	Piston	1
20006	O-Ring	1	30110	Spring	1
20007	O-Ring	1	30111	Spring	1
20008	BHCS, 1/4-20 x 5/8" w/patch	2	30112	Pin	1
20009	Dowel Pin	1	30114	Tube (.25" x 3.75")	1
20010	Dowel Pin	2	30117	Bracket	1
20011	SHCS, 10-24 x 5/8"	6	30131 Hanger Assembly		1
20012	Nut	2	15037	Bearing	1
20013	O-Ring	1	15316	Screw	1
20014	O-Ring	1	20012	Nut	1
20015	O-Ring	1	20036	C-Clip	1
20016	Bearing	1	20037	E-Clip	1
20017	Nut	1	20065	1/4-20 x 3/8" Flange Head	1
20018	Dowel Pin	1	30033	Hanger Pin	1
20020	SHCS, 8-32 x 1/4"	12	30130	Hanger	1
20021	Nut	8	55095	Hanger Yoke	1
20022	Screw	1			
20023	SHCS, 4-40 x 1/2"	4	PARTS only for 2500 Series Tools		
20026	Fitting	2	20035	Plug (Red)	1
20029	Elbow	1	30002	2500 Housing, GREEN	1
30000	Valve	1	38002	2500 Housing, BLACK	1
30001	Cap	1			
30004	Piston Assy.	1	PARTS only for 2800 Series Tools		
30005	Compression Spring	1	20025	Tee	1
30007	Spring	1	20027	Tube Fitting	1
30008	Trigger Valve	1	20028	Tube Fitting	1
30009	Valve Sleeve	1	20030	Hex Nipple	1
30010	Trigger Lever	1	30113	Slide Valve	1
30011	Trigger Assembly	1	30115	Poly Tube (.38" x 9.5")	1
30012	Side Plate, Right Hand	1	30118	Washer	1
30013	Side Plate, Left Hand	1	30120	2800 Housing, GREEN	1
30014	Top Plate	1	38120	2800 Housing, BLACK	1
30015	Pin	1	Certain parts are MODEL SPECIFIC.		
30016	Spring, Top Plate Pin	1	See chart below for those part numbers		
30017	Yoke	1	301__	Magazine	1
30018	Roller	1	301__	Liner Strip	1
30019	Link	2	301__	Cover	1
30020	Pin, Roller	1	301__	Bracket	1
30021	Pin, Blade	1	302__	Blade Guide #__	1
30022	Front Plate	1	302__	Anvil #__	1
30023	Shoulder Screw	2	302__	Blade #__	1

The Eclipser 2500/2800 Series

TOOL IDENTIFICATION

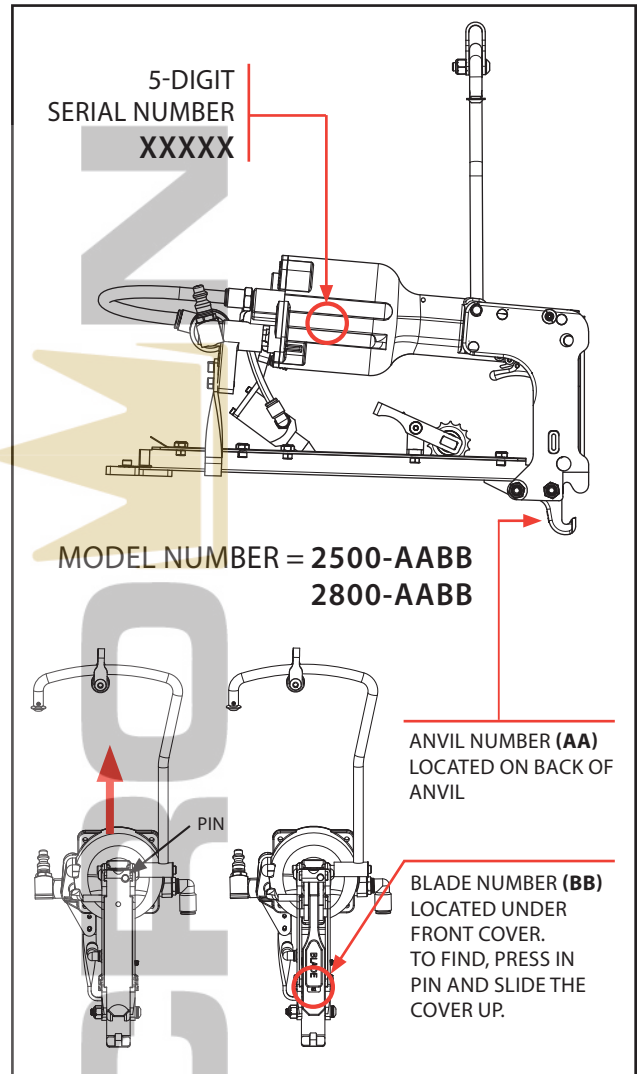

SPECIFICATIONS

WEIGHT:	2500 = 6.2 lbs (2.81 kg) 2800 = 7.0 lbs (3.18 kg)
DIMENSIONS (HxWxL):	2500 = 7.5 x 6 x 15" (190 x 152 x 381mm) 2800 = 8 x 7.5 x 15" (203 x 190 x 381mm)
COMPONENT MATERIALS:	Composite plastic housing, steel clip magazine
CLIP FEEDING METHOD:	Single acting spring extended cylinder
PRIMARY POWER UNIT:	Main cylinder - Bore 3.06" (78mm) spring return
AIR SUPPLY:	80-90 psi (5.5-6.2 BAR) of dry, lubricated air
AIR CONSUMPTION (SCFM):	3.56, assuming 90 psi and 1 cycle per second 3.22, assuming 80 psi and 1 cycle per second

MODEL-SPECIFIC PARTS

Model 2500- 2800-	Anvil 302__	Blade 302__	Blade Guide 302__	Magazine 301__	Liner 301__	Cover 301__	Bracket 301__	Fits Clip Width
1020	10	20	02	00	01	02	04	A
1022	10	22	01	00	01	02	04	A
1024	10	24	08	00	01	02	04	A
1121	11	21	01	00	01	02	04	A
6082	60	82	00	50	51	52	54	F, H
6181	61	81	00	50	51	52	54	F, H
6185	61	85	00	50	51	52	54	F, H

ECLIPSER 2500/2800 OPERATING INSTRUCTIONS

TO GET STARTED

1. For both 2500 and 2800 tools, use suitable coupler to connect air hose to pre-installed fitting as shown at right.

2. Attach clip track assembly (Part #30123 or #30157, included with Encore Hartco CC Clipping System or purchased separately) to tool using a 9/64" hex key.

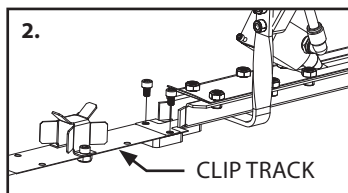
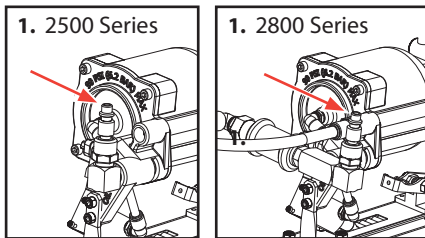

BEFORE FIRST USE AND RECOMMENDED DAILY MAINTENANCE

Add 2-3 drops of air tool oil (10-weight recommended) to pre-installed air inlet hose fitting (A) and openings between the side plates at these two locations:

- in the gap at the back of the top plate and the housing (B)
- the opening on the front plate (C), as shown on affixed label

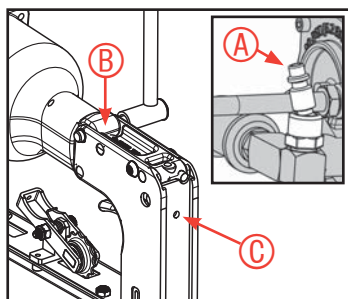

TOOL OPERATION

1. Connect air supply to air inlet hose fitting, keeping fingers and hands away from blade and anvil area. Recommended air supply is 80-90 psi (5.5-6.2 bars) of dry, lubricated air.

Eclipser air consumption (SCFM), assuming 90psi and 1 cycle per second, is 3.56. Assuming 80psi and 1 cycle per second, SCFM is 3.22.

2. Feed clips into clip track assembly and tool, pushing forward until clips stop against the tool blade.
3. Set wires to be fastened into side plate notches (D). For best results, smaller wire should be on the bottom. Squeeze trigger (E) to install clip.

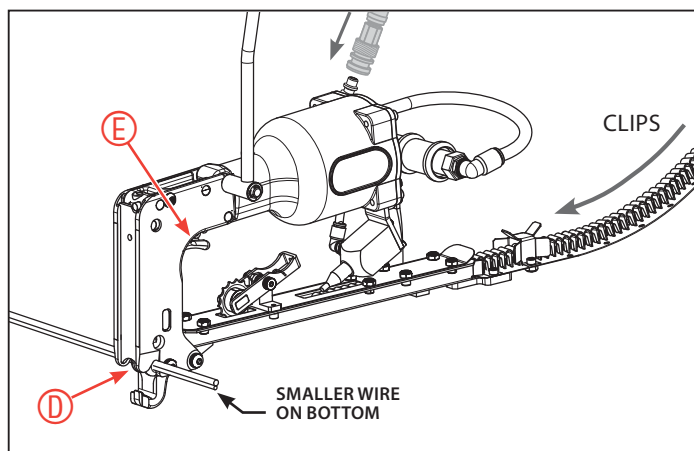

UNLOADING CLIPS

1. **DISCONNECT AIR.**
2. Lift cylinder assembly (F), used to advance clips forward, so it is not touching clips.
3. Push down on back of arm (G) holding backstop wheel against clips, raising wheel up.
4. Slide clips out of magazine.

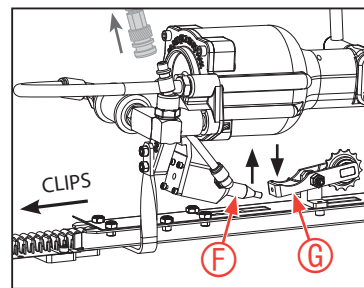

USING THE BLADE JAM RELEASE

1. While holding tool in right hand, with finger off the trigger, grasp auxiliary air valve (H) with left hand and slide it to the left. Hold valve open until driver blade activates.
2. Release valve and visually check for an obstruction. If found, disconnect air and then clear it manually.

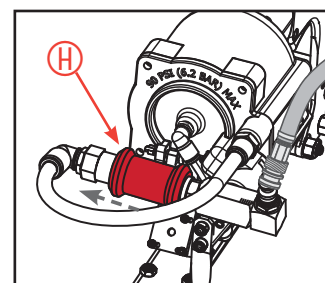

PARTS REPLACEMENT

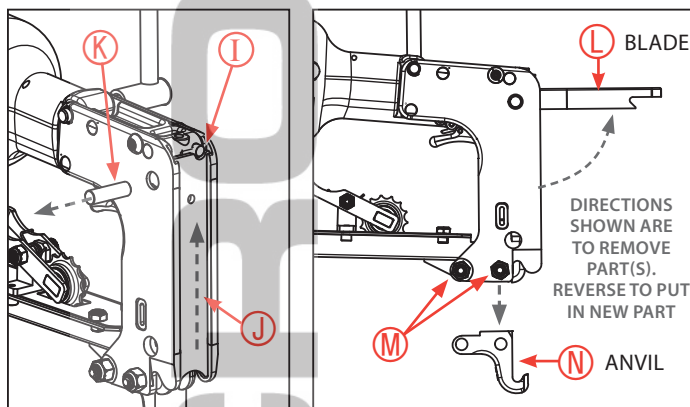

BLADE: **DISCONNECT AIR. REMOVE CLIPS FROM TOOL.**

1. Depress pin (I) at top of front plate (J); slide plate up and remove.
2. Swing blade (L) from tool and align link pin (K) with holes in side plates. Remove pin through holes and remove blade.
3. Lubricate new blade.
4. With new blade at 90° angle, align blade hole with links (Part #30019) and side plate holes on both sides. Insert link pin (K) through aligned holes to secure blade. Firmly strike blade face to swing back into original position.
5. Re-lubricate front plate. Depress pin (I) and slide front plate down until pin returns to extended position, securing plate in place.

ANVIL: **DISCONNECT AIR. REMOVE CLIPS FROM TOOL.**

1. Remove lower shoulder screws (M).
2. Remove anvil (N) and replace.

TROUBLESHOOTING for the 2500/2800

SAFETY	CAUSE	SOLUTION
Blade does not return	Sticky main valve	Lubricate main valve and check that main valve piston moves
	Loose screw in housing cap	Tighten all 4 screws in cap
Sluggish tool	Dry main valve	Lubricate main valve
Clips not feeding	Obstruction in magazine	Remove obstruction
	Clips caught in track	Inspect track, manually dislodge clips
Loose clips	Low air pressure	Increase pressure to 80 psi
	Worn blade or anvil	Replace blade or anvil
	Wrong clips for application	Review <i>E-Clips Guide, By Tool</i> , available at encorehartco.com/support
Clip jamming	Wrong size of clips loaded, or clip misaligned in chamber	Slide red auxiliary air valve to the side to relieve pressure, loosening clip chamber
Tool not cycling	Clogged trigger valve	Clean trigger valve assembly
	Obstruction in chamber	Slide red auxiliary air valve to the side to loosen obstruction

Continuous Coil (CC) Clipping System

Encore Hartco's complete clipping system has two major parts: 1) an Eclipser 2500 or 2800 Series clipping tool; and 2) a sturdy, free-standing frame with a tool balancer, rods and clip track assemblies for supplying clips. Each component is made to suit specific applications and is ordered separately. For the CC System (a tool and the frame), the customer provides:

- a 3/8" NPT air inlet fitting
- a suitable roll of clips
- compressed air (3.5 SCFM at 80-90 psi)

CC SYSTEM PARTS

Item #	Description	Qty
EA/HR 2500	Eclipser 2500-XXXX (unique for each system)*	1
EA/HR 2800	Eclipser 2800-XXXX (unique for each system)*	
*2500 or 2800 ECLIPSER TOOL #s (for each system)		
"A"	-1020, -1022, -1024, or -1121	
"F-H"	-6082, -6181, or 6185	
30180 - CC SYSTEM FRAME "A"		
30123	Clip Track Assembly "A"	1
20020	SHCS, 8-32 x 1/4"	28
20021	Hex Nut, 8-32 Thin Ht	24
30121	Clip Track "A"	1
30122	Clip Track Guide "A"	14
30190 - CC SYSTEM FRAME "E-F-H"		
30157	Clip Track Assembly "E-F-H"	1
20020	SHCS, 8-32 x 1/4"	28
20021	Hex Nut, 8-32 Thin Ht	24
30155	Clip Track "E-F-H"	1
30156	Clip Track Guide "E-F-H"	14
UNIVERSAL PARTS for CC SYSTEM FRAMES		
15100	Nut, 3/8"-16 Hex	4
15240	Washer, 3/8"	1
15256	Washer, 3/8" Locking	4
15598	SHCS, 3/8"-16 x 3/4"	1
15624	SHCS, 1/4"-28 x 3/4"	2
20028	Push-In Straight Fitting, 1/4" NPT 3/8" Tube	1
20054	3/8" Lubricator	1
20055	3/8" Regulator	1
20056	Tool Balancer	1
20057	Collar, Single Split 1/2"	2
20058	Close Nipple, 3/8" NPT	1
20060	Eye Hook, 3/8"-16	1
20063	Coil Hose Assembly	1
20167	Push-In 90° Ftg, 3/8" NPT x 3/8" Tube	1
20168	Carriage Rod	1
20170	3/8" Air Hose	1
20171	Coupler Body, 1/4" NPT x 1/4" Female	1
20172	HHCS, 3/8"-16 x 2-3/4"	4
20173	Nut, 3/8"-16 Hex Nylock	2
20177	1/4" NPT Female 90° Elbow Ftg	1
30158	Spool Support Rod	1
30159 Carriage Assembly Parts		
15150	1/2" Linear Bushing	1
20169	Internal Retaining Ring	2
65157	Block, Track Carriage	1
30164	Upright Weldment	1
30165	Upper Weldment	1
30170	Base Weldment	1

WORK SITE SET UP

REQUIRED COMPONENTS

The Eclipser 2500 and 2800 series tools are designed to install clips from a continuous roll or coil. For proper operation of the Eclipser, the following additional components will be required:

- a compressed air source;
- a clip track (P);
- a rod and track carriage system (Q) to guide clips, left to right and back again, as they unspool from the roll into the clip track;
- a heavy duty horizontal rod (R) on which to place the roll of clips, at an elevation of approximately 5 feet; and
- a roll of clips (S) suitable for your application and tool.

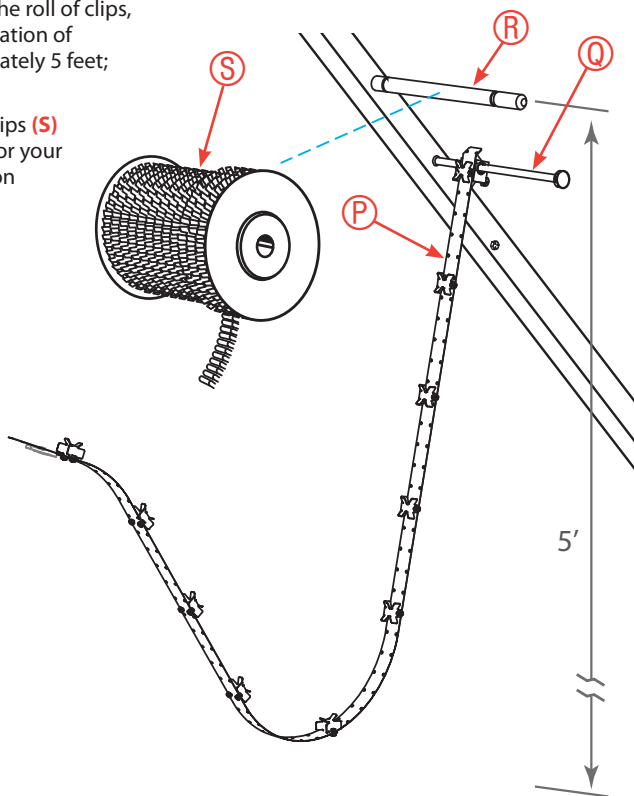

The Encore Hartco Continuous Coil (CC) Clipping System

Encore Hartco's Continuous Coil (CC) Clipping System has two major components:

- 1) An Encore Hartco Eclipser 2500 or 2800 Series clipping tool.
- 2) An assembly that includes a heavy duty, freestanding frame, spool rod, clip track, rod and track carriage system, tool balancer, hose and air regulator.

Choosing your CC Clipping System...

1. Measure the width of clip to be used for fastening:

If clip width is:	Clip style is:
7/16" (11.0 mm)	"A" (Narrow)
11/16" (17.5 mm)	"E"
3/4" (19.0 mm)	"F"
7/8" (22.0 mm)	"H"

2. Choose an Eclipser model:

For "A" Narrow Width Clips	For "F" and "H" Width Clips
2500-1020	2500-6082
2500-1022	2500-6181
2500-1024	2500-6185
2500-1121	2800-6082
2800-1020	2800-6181
2800-1022	2800-6185
2800-1024	
2800-1121	

For models that take "E" width clips, call or visit us on the Web

3. Choose a CC System Frame:

For "A" Narrow Width Clips	For "E", "F" and "H" Width Clips
Frame "A" (30180)	Frame "E-F-H" (30190)

