

ELECTRIC TOOL PARTS LIST

■ **IMPACT DRILL**
Model DV 16V

2003 • 12 • 10
(E1)

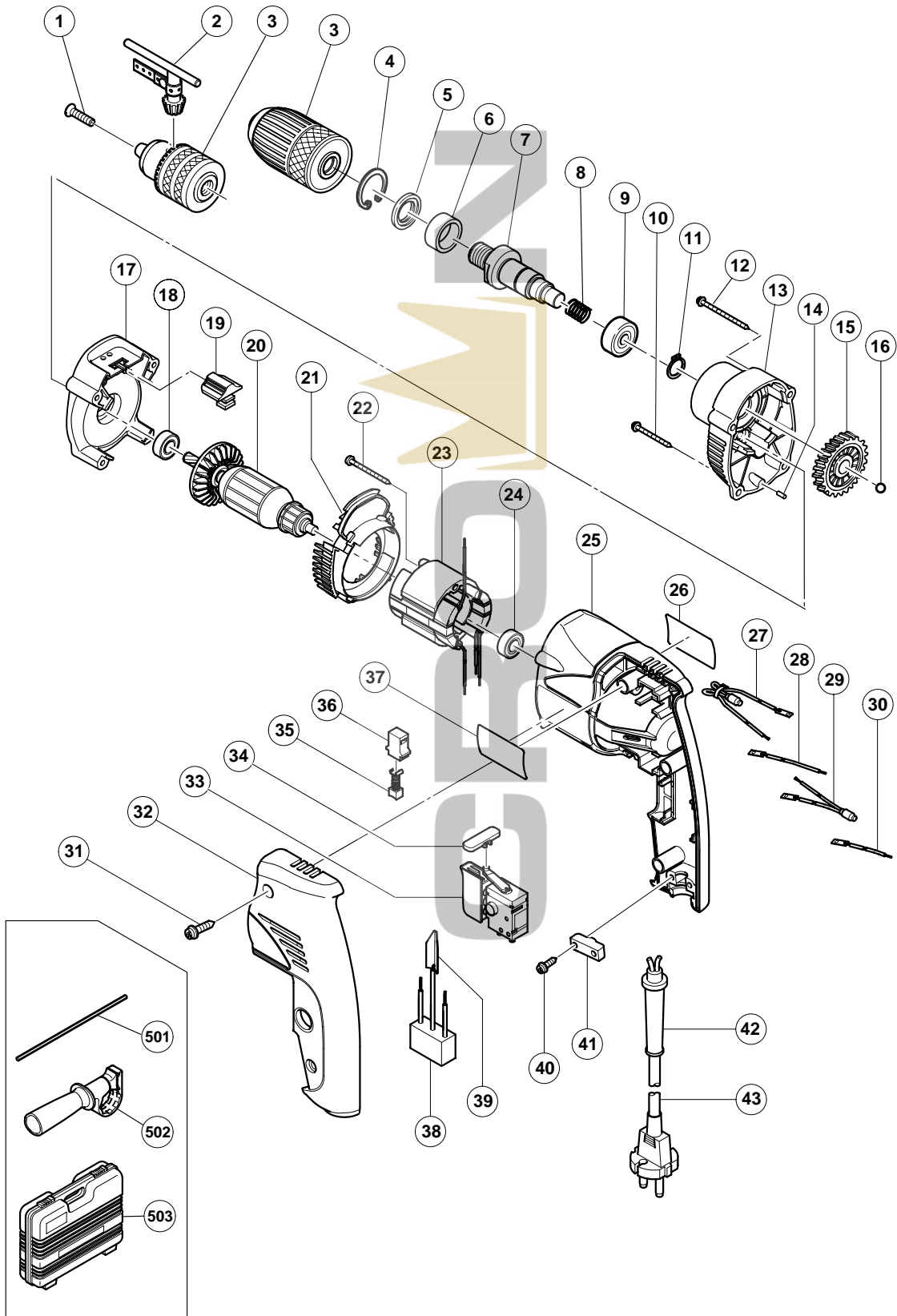

PARTS

DV 16V

ITEM NO.	CODE NO.	DESCRIPTION	NO. USED	REMARKS
1	995-344	FLAT HD. SCREW (A) (LEFT HAND) M6X25	1	
2	987-576	CHUCK WRENCH FOR 13VLB-D,13VLR-D	1	
* 3	322-357	DRILL CHUCK 13VLRH-N (W/O CHUCK WRENCH)	1	
* 3		DRILL CHUCK 13VLRB-D	1	INCLUD. 2 SUPPLIED WITH ITEM NO.601
4	948-001	RETAINING RING FOR D32 HOLE	1	
5	971-654	DUST SEAL	1	
6	322-515	DISTANCE RING	1	
7	322-513	SPINDLE	1	
8	322-514	SPRING	1	
9	600-2VV	BALL BEARING 6002VVCMP2L	1	
10	306-664	TAPPING SCREW (W/FLANGE) D4X40	2	
11	939-544	RETAINING RING FOR D15 SHAFT (10 PCS.)	1	
12	322-516	TAPPING SCREW (W/FLANGE) D4X55	2	
13	322-512	GEAR COVER	1	
14	322-511	NEEDLE (B)	1	
15	317-482	GEAR	1	
16	959-150	STEEL BALL D6.35 (10 PCS.)	1	
17	322-509	INNER COVER	1	
18	608-DDM	BALL BEARING 608DDC2PS2L	1	
19	322-510	CHANGE LEVER	1	
* 20	360-626C	ARMATURE 110V	1	
* 20	360-626U	ARMATURE ASS'Y 120V	1	INCLUD. 18, 24
* 20	360-626E	ARMATURE 220V-240V	1	
21	322-508	FAN GUIDE	1	
22	950-515	TAPPING SCREW D4X50	2	
* 23	340-573C	STATOR 110V	1	
* 23	340-573D	STATOR 120V	1	
* 23	340-573E	STATOR 220V-230V	1	
* 23	340-573F	STATOR 240V	1	
24	608-VVM	BALL BEARING 608VVC2PS2L	1	
25	321-622	HOUSING	1	
26		NAME PLATE	1	
* 27	322-517	CHOKE COIL (BROWN) 220V-240V	1	EXCEPT FOR USA, CAN
* 27	322-518	CHOKE COIL (BROWN) 110V	1	FOR GBR (110V)
* 28	321-630	INTERNAL WIRE (BROWN) 100L	1	FOR USA, CAN
* 29	321-634	CHOKE COIL (BLUE) 110V-240V	1	EXCEPT FOR USA, CAN
* 29	322-519	CHOKE COIL (BLUE) 110V	1	FOR GBR (110V)
* 30	321-631	INTERNAL WIRE (BLUE) 55L	1	FOR USA, CAN
31	301-653	TAPPING SCREW (W/FLANGE) D4X20 (BLACK)	3	
32	321-629	HANDLE COVER	1	
33	321-632	SWITCH (1P PILLAR TYPE)	1	
34	321-628	PUSHING BUTTON	1	
35	999-041	CARBON BRUSH (1 PAIR)	2	
36	955-203	BRUSH HOLDER	2	
37		HITACHI LABEL	1	
* 38	994-273	NOISE SUPPRESSOR	1	EXCEPT FOR USA, CAN
* 39	992-635	EARTH TERMINAL	1	FOR NOISE SUPPRESSOR
40	984-750	TAPPING SCREW (W/FLANGE) D4X16	2	
41	937-631	CORD CLIP	1	
42	953-327	CORD ARMOR D8.8	1	
* 43	500-247Z	CORD	1	(CORD ARMOR D8.8)

