

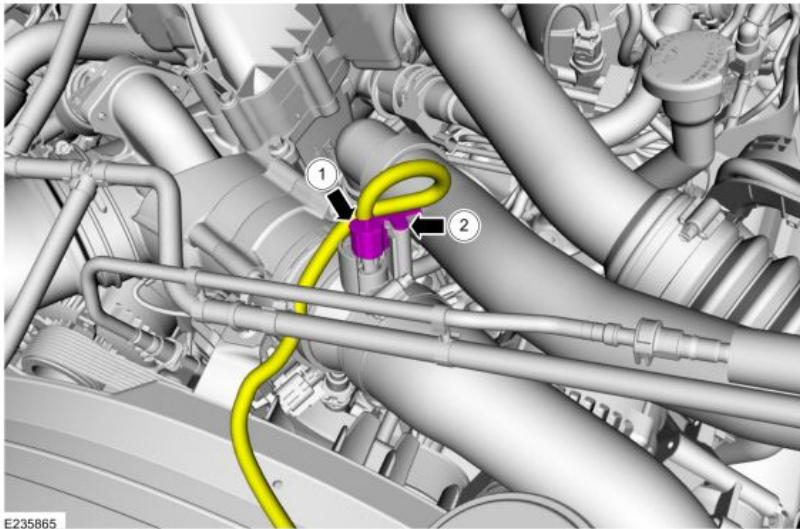

## (94181) 17-19 6.7 Powerstroke Cold Side Intercooler Pipe

1. Disconnect the CAC temperature sensor electrical connector. Detach the retainer and position the wiring harness aside



2. Loosen the T-bolt clamp at the outlet of the intercooler. Release the clip and remove the CAC outlet pipe assembly.

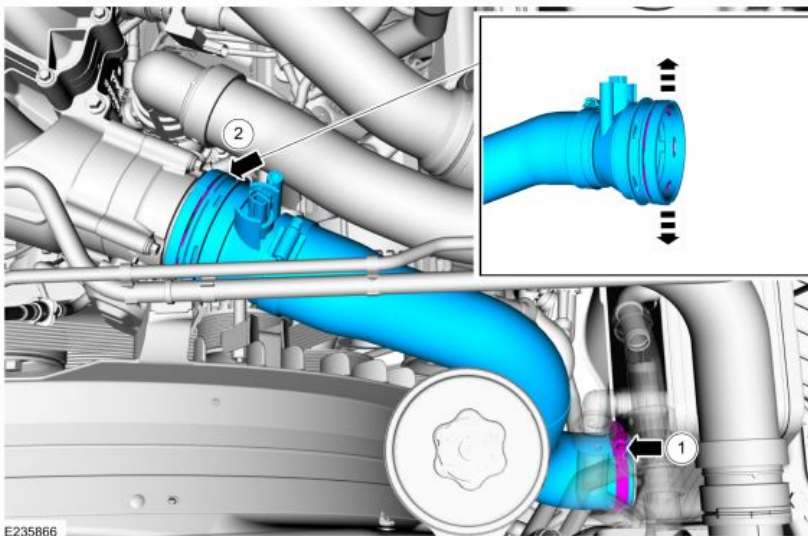

3. Install the supplied o-ring into the new throttle body adapter. You will also be installing/reusing the spring clip out of the old adapter.

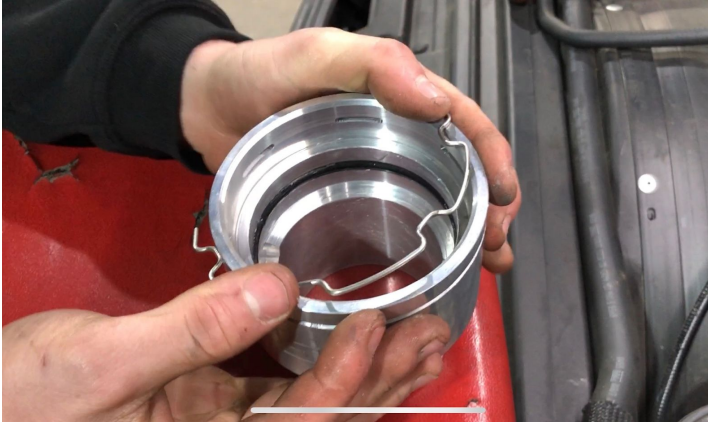

4. Install the supplied plug fittings into the adapter. At this point if you are planning to use an injectable or a port for reference (boost gauge/sensor, temp etc) this would be the time to install



it.

5. After assembling the adapter lube the o-ring with a dielectric grease or equivalent. Install the adapter onto the throttle body make sure the o-ring starts on even, push until you hear a click.



6. Rotate the adapter so the CAC sensor hole is accessible. Install the sensor as factory, twisting clockwise. Re-route the electrical connector and wiring making sure it clears and doesn't snag.

Connect the sensor and then rotate it downward. This will allow port access.

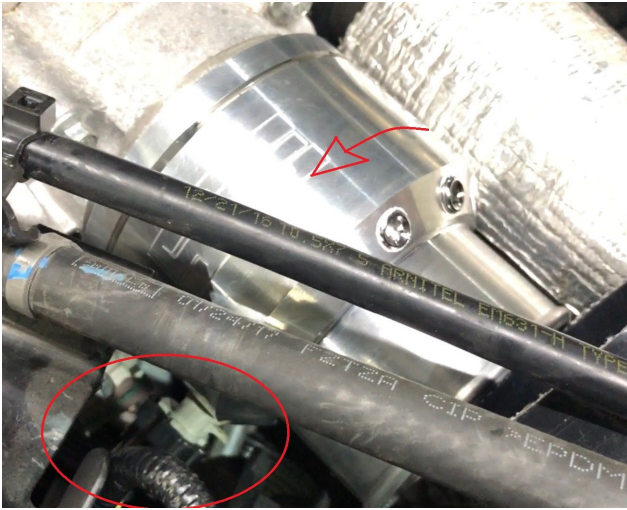

7. Install the supplied clamps onto the charge hose loosely so they can be adjusted and moved. Install the hose onto the intercooler and then the throttle body adapter.



8. Tighten the T-bolt clamps after adjusting the pipe for best fitment.



9. After completing your install we recommend driving the truck for a day or two allowing for heat cycles, then going over your hose clamps to make sure they are nice and tight.