

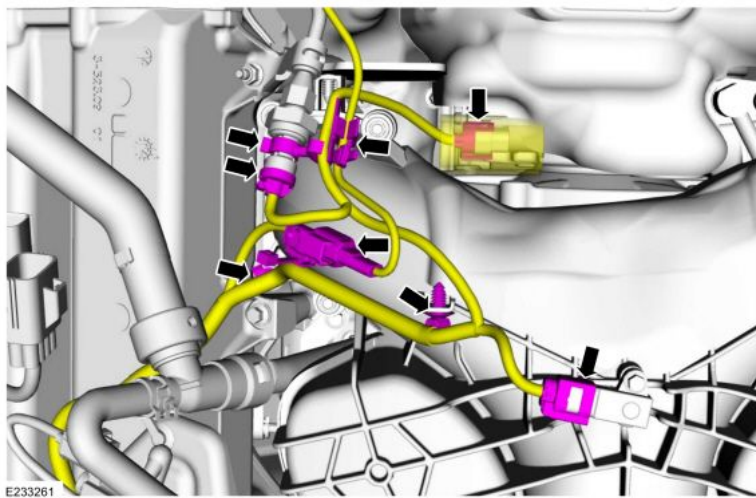

2017-2019 6.7 Powerstroke Disaster Prevention Kit

****Note- For sealant SPE recommends Vibra-tite 44050, loctite 545 or Teflon tape.**

1. Remove the upper and lower intake manifold to gain access to the top of the CP4 pump. Disconnect/remove the Purple connections and bolts.

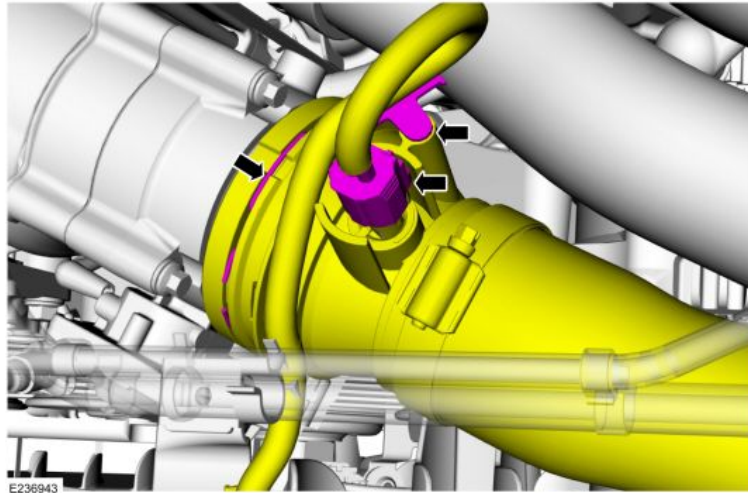

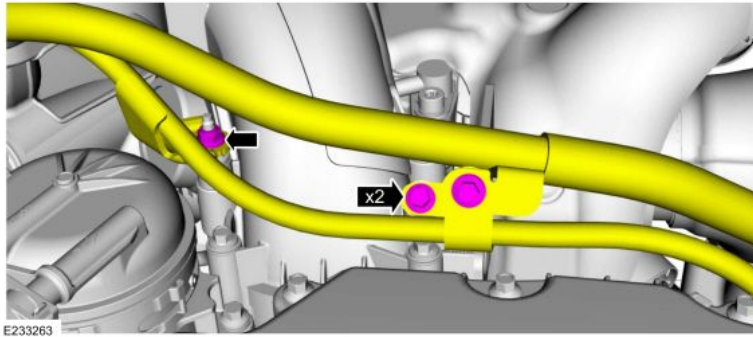

E233263

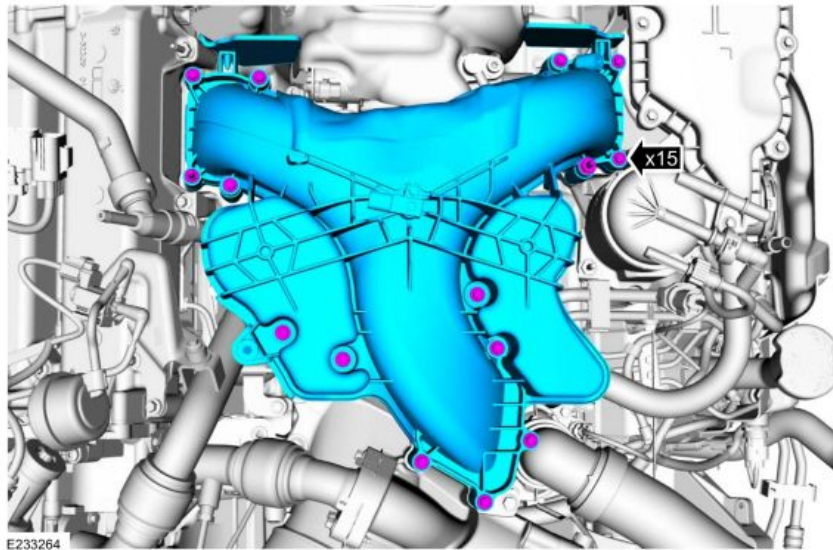

E233264

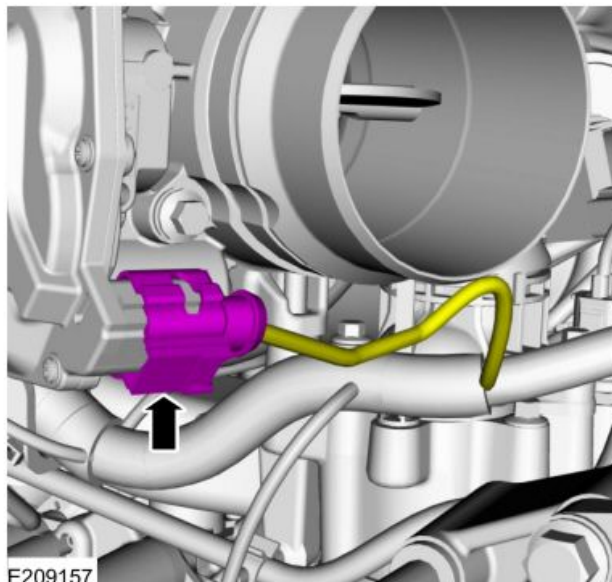

E209157

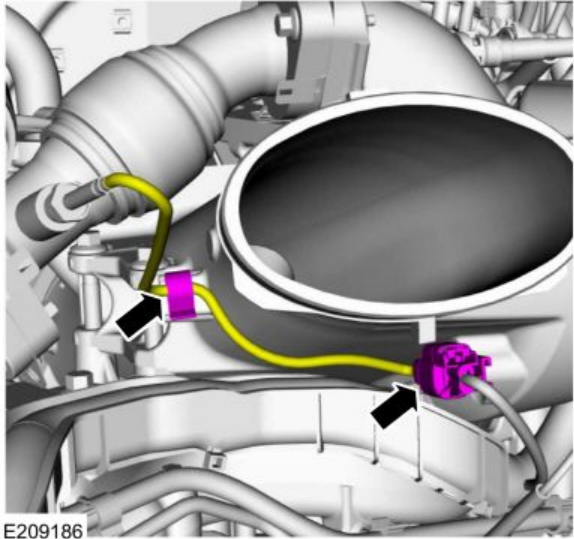

E209186

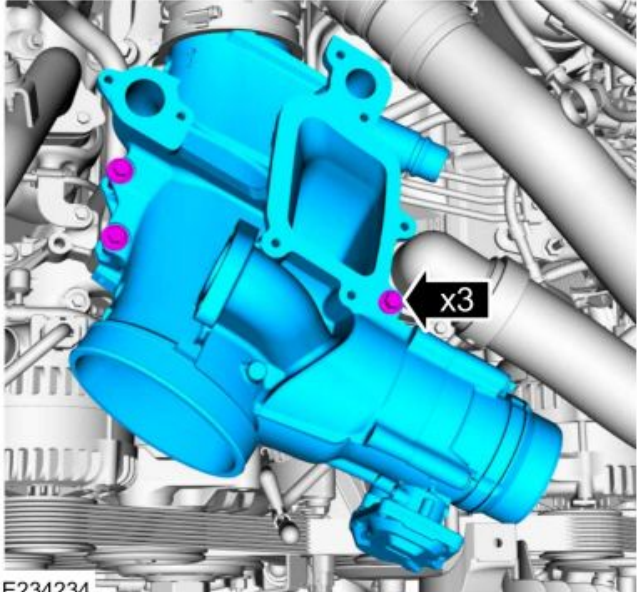
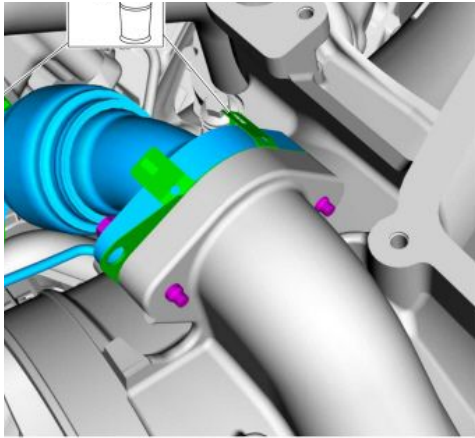

E234234

2. Next, disconnect the fuel filter outlet quick connect (both ends) from the filter and rail. You can replace the fuel filter at this time or only remove the one fuel hose as noted below.

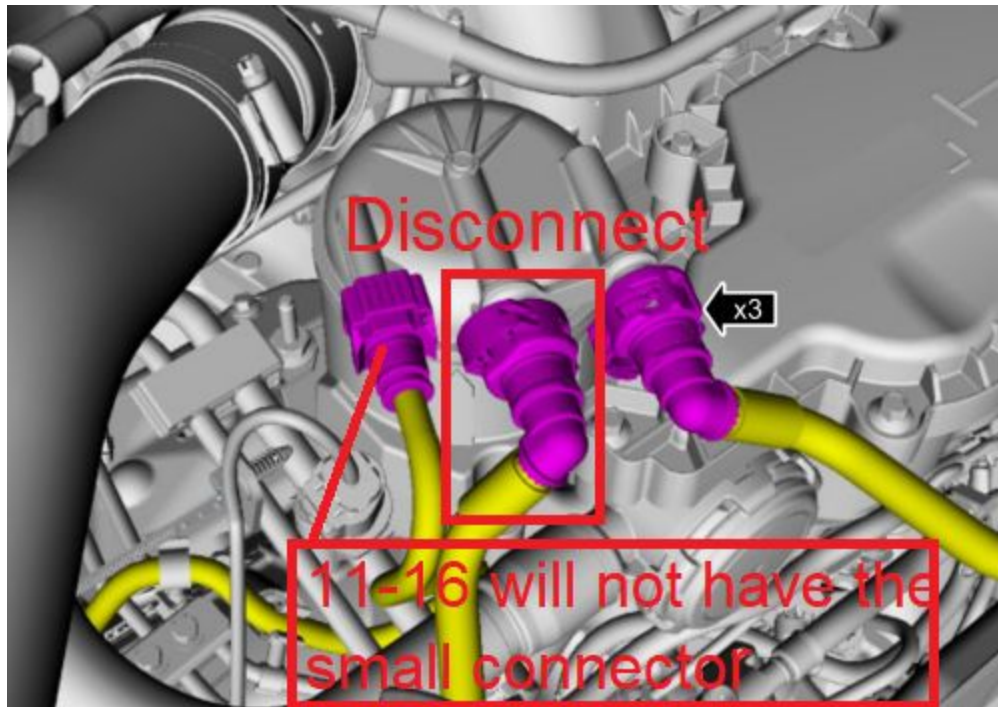

3. With the top of the cp4 now accessible remove the Volume Control Valve (MPROP) Be sure to take note of the tightness.

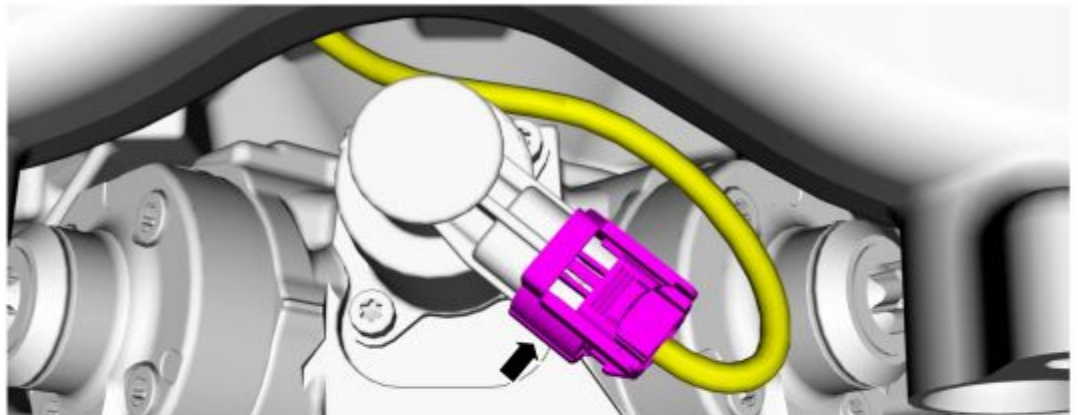

4. **IMPORTANT!! MAKE SURE NO DEBRIS FALLS INTO THE PUMP!! MAKE SURE THE BORE IS PERFECTLY CLEAN. IF NOT THIS WILL CAUSE DAMAGE TO THE PUMP!!!!!!**

5. Prep the SPE MPROP Adapter to go into the pump. Using teflon tape, wrap the 90 degree 1/4NPT to -6 adapter fitting and install as shown. DO NOT TAPE THE CONE SIDE OF THE FITTINGS THOSE ARE CONICAL SEAT!!

****Note- For sealant SPE recommends Vibra-tite 44050, loctite 545 or Teflon tape.**

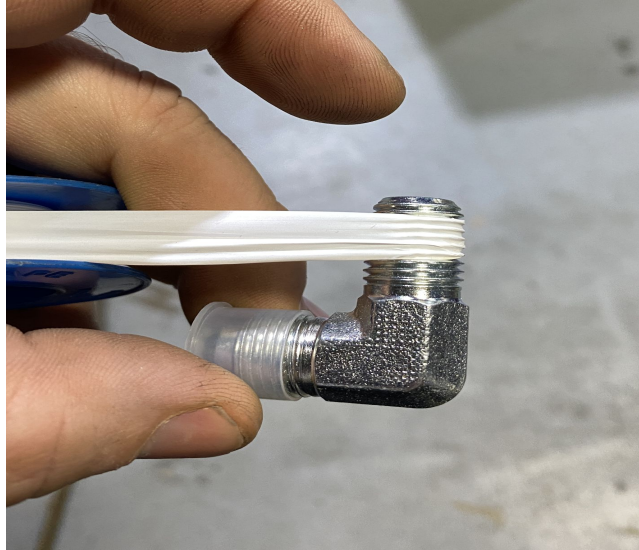

6. Orient the fitting like below.



7. Install the 2 supplied o rings on the base of the adapter. After making sure the bore of the pump is clean push the adapter in until seated flat in the pump.

8. Install the volume control valve (MPROP) into the adapter with the supplied longer stainless allen bolts. Tighten to 35-45 inch pounds. If you do not have access to an in-lb torque wrench the tightness is similar to that when you removed it.

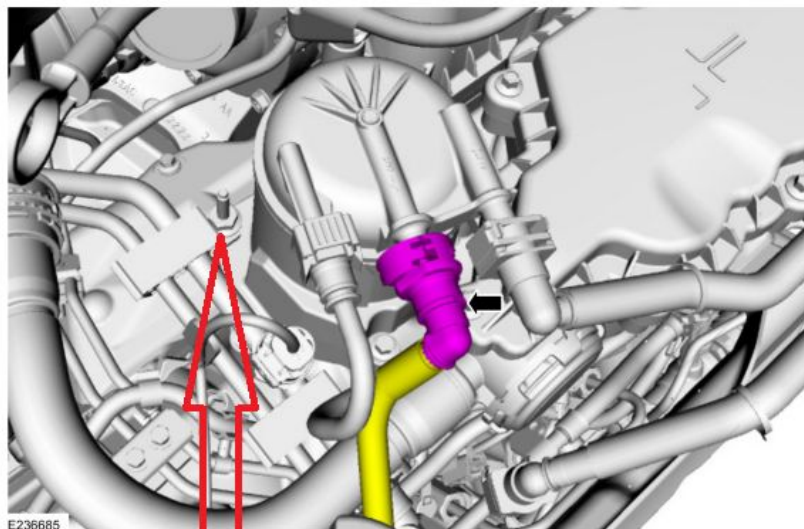
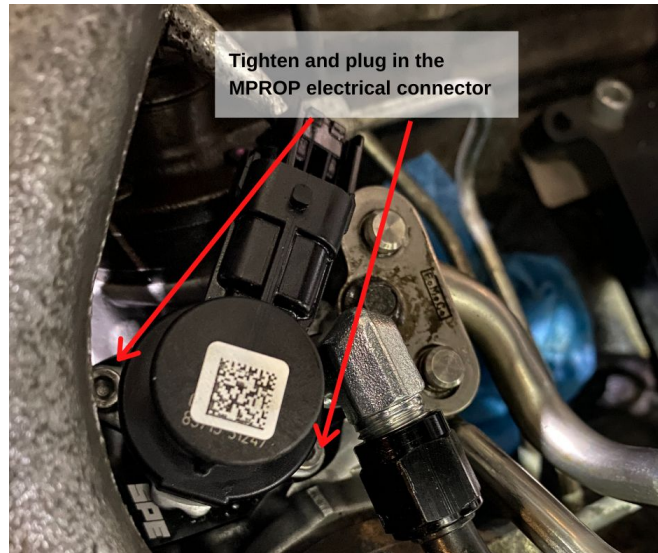

Install included black Spacer under the fuel line bracket.

9. Screw on the 45 degree end of the supplied premade hose tighten with the fitting pointing up.



10. Teflon tape and install the fittings into the Fuel manifold as shown below.



11. Install the fuel manifold on the fuel line as shown using the taller of the two included retaining washers and included M6 allen bolt. Tighten premade hose nut, and install the quick disconnect hose to the fuel filter and manifold.

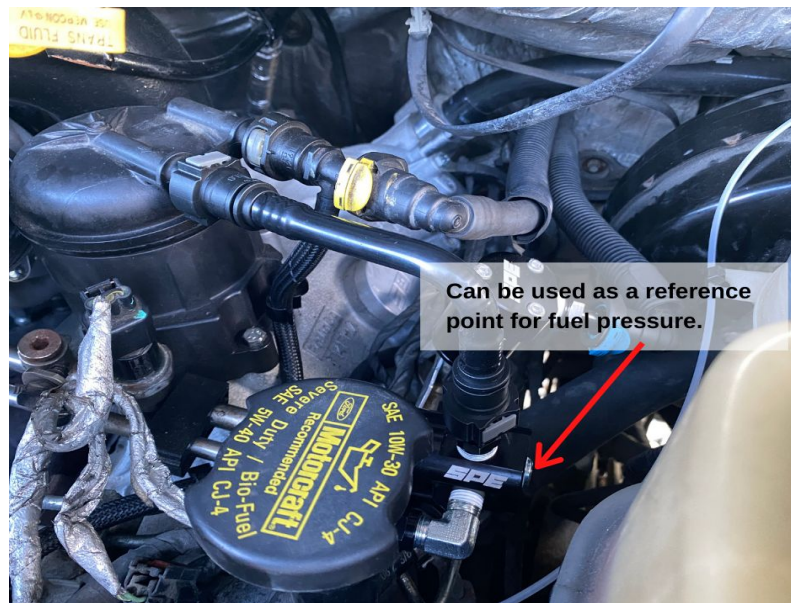

12. Before reassembling the rest of the components, turn the ignition on and allow the lift pump to prime the fuel system and thoroughly check for leaks. Once you have checked and addressed any leaks you can now reassemble the rest of the removed components.

13. Once the truck is reassembled, allow it to idle for 5 to 10 minutes to get any air out of the fuel system before driving. You may now enjoy your truck with a piece of mind and all the added benefits of the SPE 6.7 Powerstroke disaster prevention kit.

14. To install the SPE Exofilter kit, please reference those directions which can be found on the SPE Motorsport website or separately in your package.