

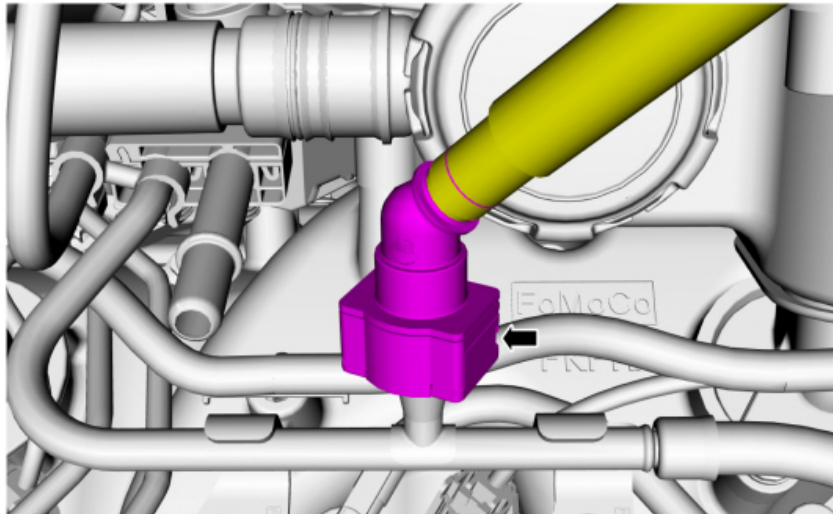

2011-2021 6.7 Powerstroke 6.7 ExoFilter Kit

1. Disconnect the return fuel quick connect hose on the driver side of the engine. Push to the side.



2. Build the exo filter assembly on the bench. Install the o-ring and filter screen into the body. Install the fitting into the filter lid as shown below. **The quick connect fitting has an O ring and doesn't need sealant.** Then, place the lid over the filter and tighten down with the 3 supplied bolts.





3. Push the main assembly down onto the return outlet of the rail. Place the retainer ring underneath and tighten down with the supplied M6 bolt.
4. Reconnect the fuel return hose. The quick connect end on the hose may need to be spun/twisted to orient it correctly. Do not just twist the hose it will kink. If needed you can carefully use a heat gun to soften the nylon hose to allow the fitting to spin. It only needs to be hot to the touch and also take care to only heat the hose closest to the fitting. Once it cools it will reseal. The install is now complete.



*****SPE recommends checking the ExoFilter when changing your main fuel filters on the truck. This helps monitor the health of your fuel system The filter will have small debris stuck in it on the bottom side if a failure is starting to occur. We recommend removing the screen and spraying brake cleaner from the top side of the screen above a paper towel. This is a great way to see what's in it and also clean it out. The screens are 100% reusable, but can be replaced. Contact SPE to purchase a replacement.