

Dear Gardener,

First of all, thank you for your purchase. Your support of our business is the lifeblood that allows us to fulfill our mission: to teach the world to grow. We're grateful for it and do not take it for granted.

Your Cedarline Elevated Planter is constructed from the highest-quality cedar possible: 100% North American Western Red Cedar. It contains natural oils and tannins that protect it from weathering, rotting, decay, and termite damage.

The custom-profiled side panels create a gorgeous aesthetic, and your bed features a top cap ledge that's perfect to set your gloves, snips, and coffee on as you work in your garden.

I hope you find a deep joy in using this bed and growing the veggies, herbs, and flowers you've dreamed of. If you have any questions, reach out to customerservice@epicgardening.com and we'll take care of you ASAP.

Keep on growing,



Kevin Espiritu
Founder,
Epic Gardening

Kevin E.

FAQs



Scan the QR code for product details, installation video, and more FAQs!

Do I need to apply a finishing oil to my planter?

Finish is optional and will allow for the natural cedar colors to shine and be preserved. If left unfinished, cedar will naturally become a silvery grey tone from exposure to UV light and the elements. The color won't change the longevity of the beds and is simply a preference.

Where should I install my planter/raised bed?

These elevated planters can be installed anywhere from balconies, patios, paved, and unpaved parts of your yard. On soil they will tend to sink in so placing the bed on some pavers is recommended for both stability and longevity.

How do I fill my new planter/ bed?

To make filling your bed as simple as possible we've calculated the soil volumes for this model already. We have provided them in cubic feet, cubic yards and quarts to help you source your growing medium more efficiently.

Cedarline Large Elevated Planter

15" Depth Soil Volume:
16.25 Cubic Feet, .6 Cubic Yards, 486 Quarts

11.5" Depth Soil Volume:
12.5 Cubic Feet, .46 Cubic Yards, 374 Quarts

8" Depth Soil Volume:
8.75 Cubic Feet, .33 Cubic Yards, 262 quarts

What is the estimated time it will take to assemble, and can I do it myself?

All of our beds are designed to be assembled solo within approximately one hour. However, for lifting and positioning the bed, we suggest having an additional person to help, as it not only makes the process smoother but also ensures easier handling.

Optional: A compostable burlap liner is included in the box which can be laid on top of the floor boards before filling with soil. This can be used to reduce the soil spill at the initial filling.



Want to see how your product was made?

Scan the QR code to watch how we make our cedar raised beds & elevated planters!

Designed in-house and manufactured by our partners in the Pacific Northwest, you'll see the complete journey from tree to planter.

Looking for more gardening advice?
Find us on our blog or follow us below!



Question? Contact Us:
customerservice@epicgardening.com



Cedarline Large Elevated Planter Assembly Instructions



IMPORTANT: Read before beginning

- For best results assemble and install the planter on a smooth level surface. These are fantastic for patios, decks and balconies
- If installing on a soil surface it can be helpful to lay concrete pavers, bricks or one inch of tamped gravel where the legs will be. The legs can sink into soft soil over time causing the planter to become crooked or lower than desired.
- Wear gloves to avoid potential slivers
- Due to the dovetail construction, it is important that the side boards are installed perpendicular to the legs.

- If the boards become crooked it can cause binding which makes sliding the dovetail ends much more difficult.
- Ensure the dovetail boards are oriented with the profiled side facing out and with the longer sloping surface on the top.
- Determine the depth you would like the soil in your planter to be. The depth can be selected by adjusting where the (d,e) Floor Cleat board is installed on the sides of the planter. Available soil depth can be set at 15", 11.5" or 8" to accommodate your needs.

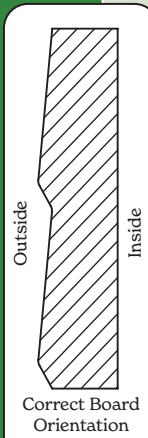

Included components:

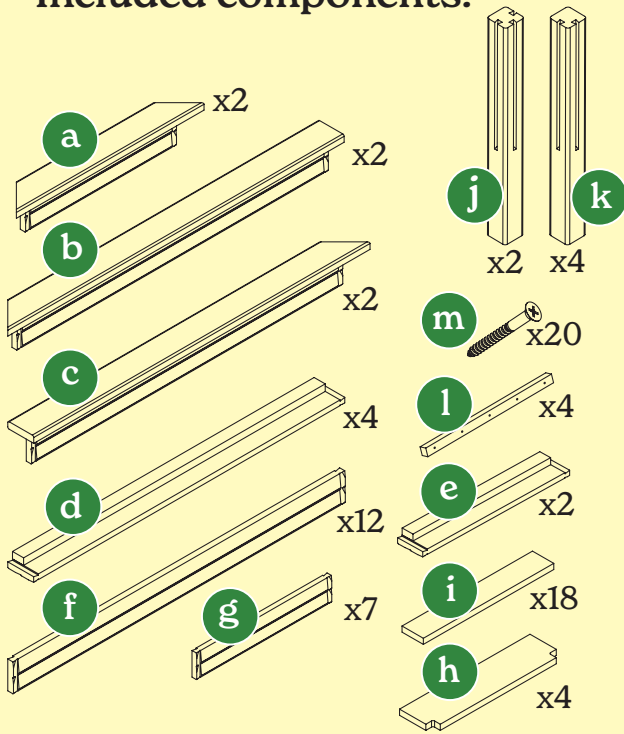

Helpful Equipment:

4 Foot Level | Gloves | Philips Head Screwdriver
HG-RBED-00002 | R 03-24

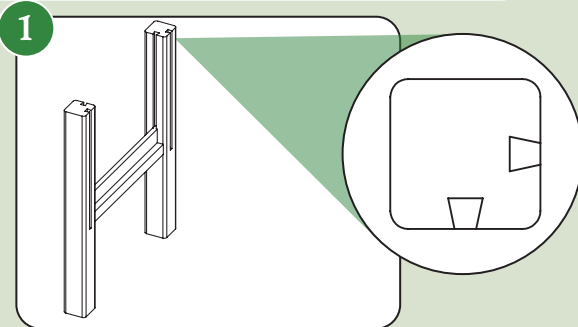

Stand two of the 2 way corner legs (k) parallel to one another so that two of the dovetail joints are facing each other and the other two are pointing in the same direction. Slide the short Floor Cleat boards (e) into the opposing dovetails until they are all the way at the bottom of the channels. The floor cleat should be on the side with the unused dovetail joints and the textured side will be the outside of the planter. Repeat with the other 2 way corner legs.

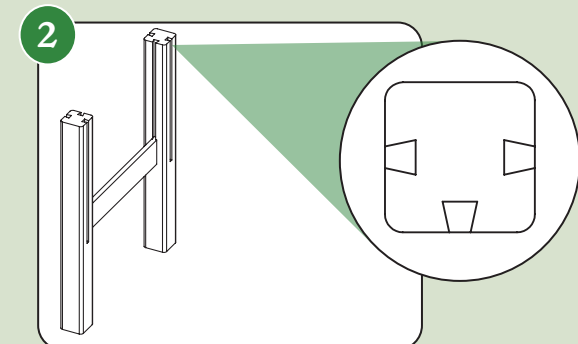

Stand the 3 way planter (j) legs parallel to one another so that the middle dovetail channels are facing each other. Slide (g) one short profiled board into the channels until it is resting at the bottom of the channel.

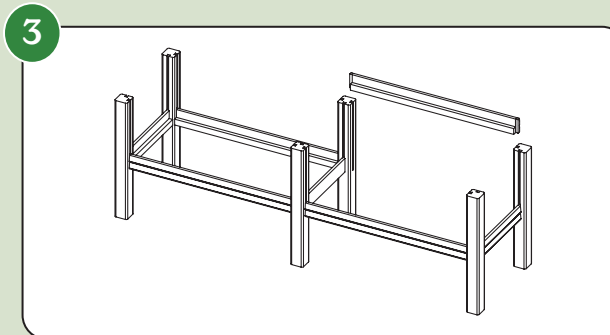

Slide the remaining side boards (f, g) into the dovetail channels ensuring the profiled side of the boards are facing the outside of the planter. Repeat this until all boards have been used.

NOTE: No more boards will be used to connect the middle legs.

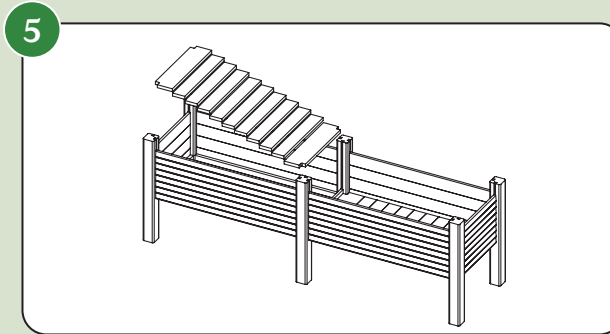

Place the floor boards to create the bottom of the planter. The boards with notched corners (h) will fit around the corner legs and rest on the narrow end cleat as well as the long side cleats. The remaining two notched boards (h) will fit around the middle legs so that the long notched sides are facing each other. Fill in the remaining space with the remaining narrow floor boards (i), resting the ends on the long side cleats. There will be space between the boards to allow for drainage.

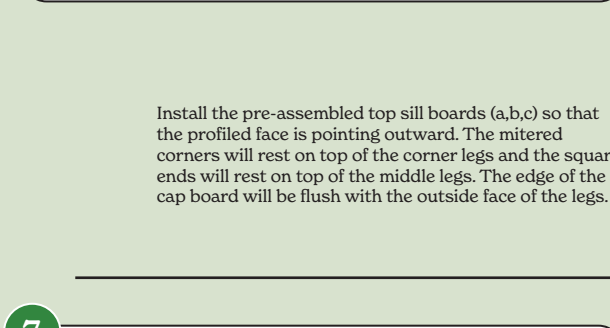

Install the pre-assembled top sill boards (a,b,c) so that the profiled face is pointing outward. The mitered corners will rest on top of the corner legs and the square ends will rest on top of the middle legs. The edge of the cap board will be flush with the outside face of the legs.

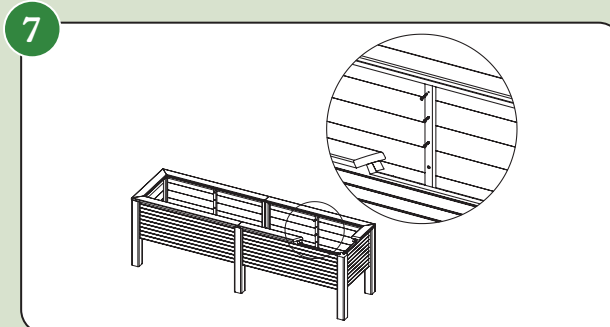

To install the recommended alignment brace (l) find the center of each of the long side panel sections. Place a flat face with through holes on the inside face of the panels so that the brace is running vertically and the top edge of the brace rests just under the top sill. Use the provided screws (m) to attach the brace to the side panel boards. Tighten the screw through the pre-drilled holes until the screw head is flush with the surface of the brace.

IMPORTANT:

Iron based tools can react with cedar and create black staining. The staining is removable but best practice is to avoid storing iron tools on the bed.