

## Assembly Instructions

Product size:

W160/165 x D77 x H94 CM

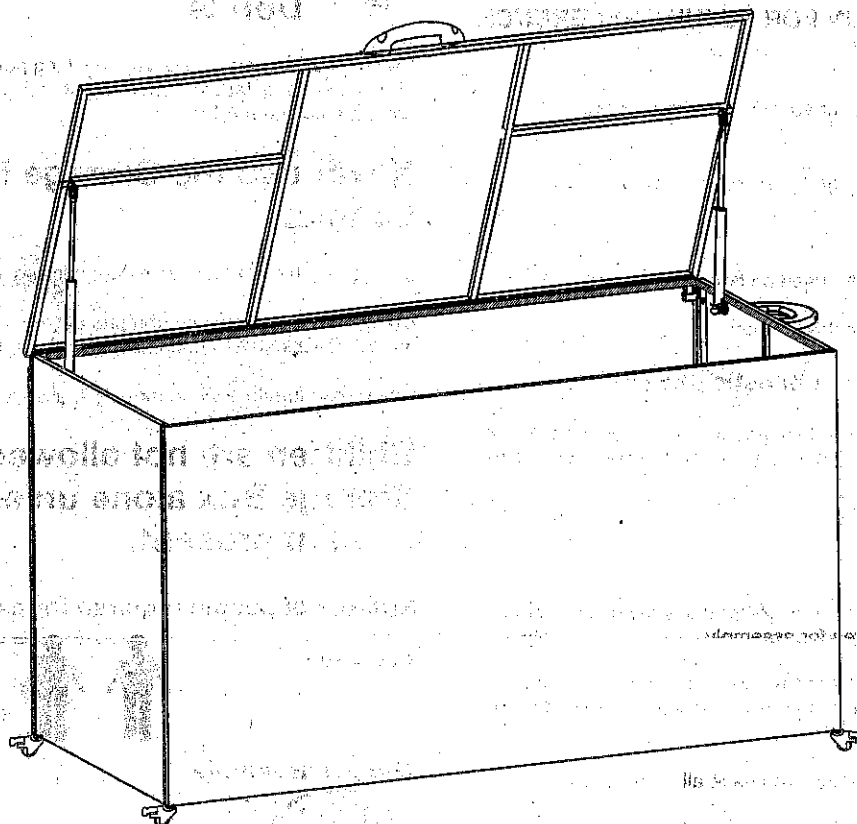

**Furniture should be covered/stored whilst not in use to prolong its longevity.**

**(It should also be covered in adverse weather.)**

**This Box is mainly for storing the light things. Please DO NOT OVERLOAD.**

**IMPORTANT, RETAIN FOR FUTURE REFERENCE**

**READ CAREFULLY**

**Note: There are Brakes on the Castors. Always Press the Brakes to stop the Box when the idea location is selected.**

**Always Release the Brakes before moving the Box to avoid the castor damage.**

## Before you start

### Warnings

#### IMPORTANT, RETAIN FOR FUTURE REFERENCE READ CAREFULLY

See enclosed instructions for assembly, safety and care information.

Failure to follow the warnings could result in serious injury.

Handle heavy parts with care.

This product should only be used on firm, level ground.

Do not stand or climb onto this product.

This product is intended for **domestic use** only.

Furniture can be dangerous if incorrectly used. No liability will be accepted for damage or injury caused by incorrect use of this product.

### Dos

When you are ready to start, make sure that you have plenty of space and a clean, dry area for assembly.

Remove all packaging and banding and place the components carefully on suitable surfaces to prevent damaging or scratching them.

Check the pack and make sure you have all parts listed.

We recommend the use of furniture covers to protect your product when not in use.

This product is suitable for outdoor use in sunny days.

To prolong the life of the product we recommend that during severely bad weather and during the winter months, it is stored in a cool, dry place.  
Before storage, ensure that the product is clean and dry.

To clean, wipe down with a sponge and warm soapy water and wipe with a clean, dry cloth.

### Don'ts

Do not use scourers, abrasives, washing powders, chemical cleaners or any other substances containing abrasives since these substances can damage the product.

#### Never use the Storage Box as a bench.

Do not use this product if parts are missing, damaged or worn.

Do not stand or climb onto the product and do not use it as a ladder, as this could lead to it unbalancing and overturning.

Never drag furniture when moving it, always lift it.

#### Children are not allowed to use this Storage Box alone unless there is adult at present.

#### Number of people required for assembly

Two people



#### Time to assemble



50 Minutes

#### Tools required

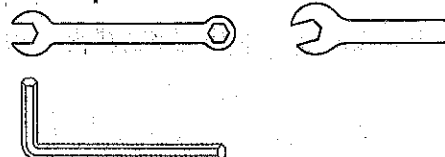





#### Tips:

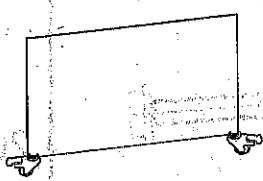
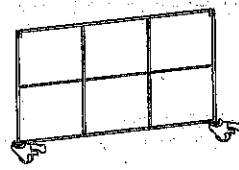
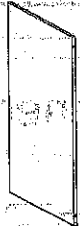
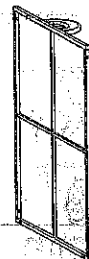

**Do NOT fully tighten bolts before all components are connected. Only fully tighten once you are satisfied with the alignment of all components.**

**Do not overtighten the bolts.**

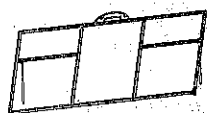
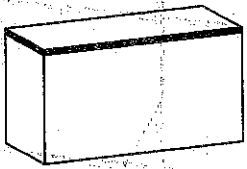
[www.royalcraft.co.uk](http://www.royalcraft.co.uk)

Components, fixtures & fittings (not actual size)

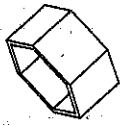
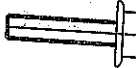
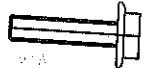
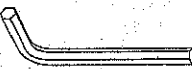
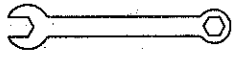
Parts List					
Part No.	Diagram	Qty.	Part No.	Diagram	Qty.
A	 Front Panel	1 PC Castor is to be assembled by the user.	B	 Back Panel	1 PC Castor is to be assembled by the user.
C	 Side Panel	1 PC	D	 Side Panel	1 PC Handle is to be assembled by the user.
E	 Bottom Panel	1 PC	F	 Lid with Pneumatic Rod	1 PC Handle is to be assembled by the user.
G	 Lining	1 PC	H	 Handle	2 PCS
			I	 Castor	4 PCS

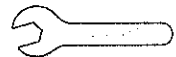
F2	 Washer	4 PCS	F3	 Bolt Head Cap	4 PCS
W30	 M6*30mm Bolt	4 PCS	W40	 M6*40mm Bolt	20 PCS
AK	 Allen Key	1 PC	S1	 Spanner	1 PC
N20	 M6*20mm Bolt	4 PCS	S2	 Spanner	1 PC

## Step by step assembly instructions

### Step One

With the help of another person, attach the Back Panel (B), Side Panel (C) and Side Panel (D) together using Bolts (W40).

**NOTE:**  
Do not fully tighten any of the bolts until all bolts are in place and aligned.

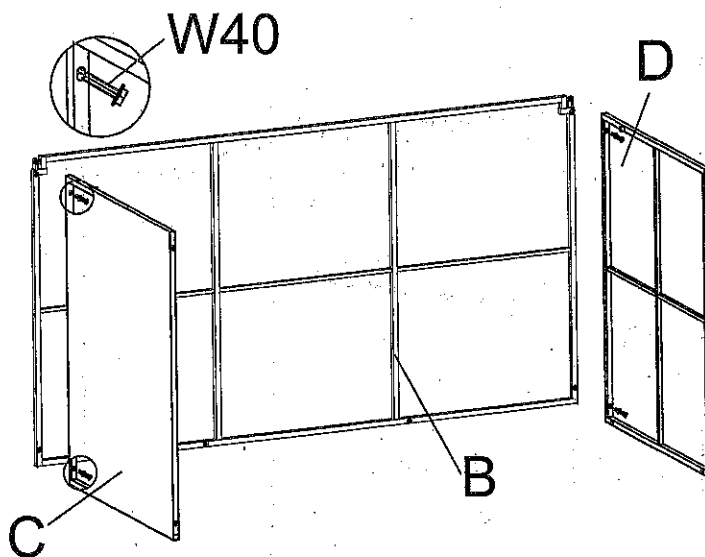

## Step Two

With the help of another person, attach the Front Panel (A) to the Side Panel (C) and Side Panel (D) using Bolts (W40).

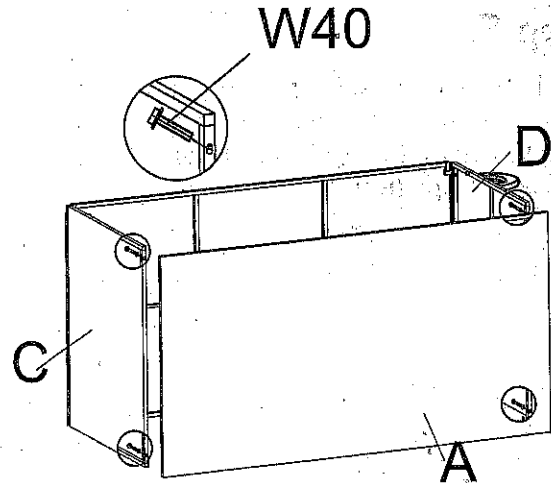

## Step Three

With the help of another person, turn over above partly-assembled parts, attach the Bottom Panel (E) to the Front Panel (A), Back Panel (B), Side Panel (C) and Side Panel (D) using Bolts (W40).

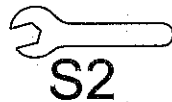

Castor (I)

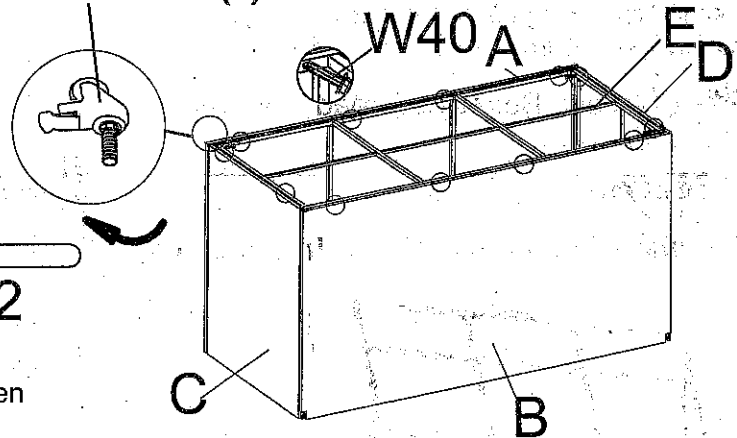

Attach the Castors (I) to the bottom of the Front Panel (A) and Back Panel (B), tighten them with Spanner (S2).

## Step Four

With the help of another person, carefully place the partly-assembled parts in the upright position.

Attach the Lid (F) to the Back Panel (B) using Washers (F2), Bolts (W30) and Bolt Head Caps (F3).

Attach the Handles (H) to the Lid (F) and Side Panel (D) using Bolts (N20), tighten with Allen Key (AK).

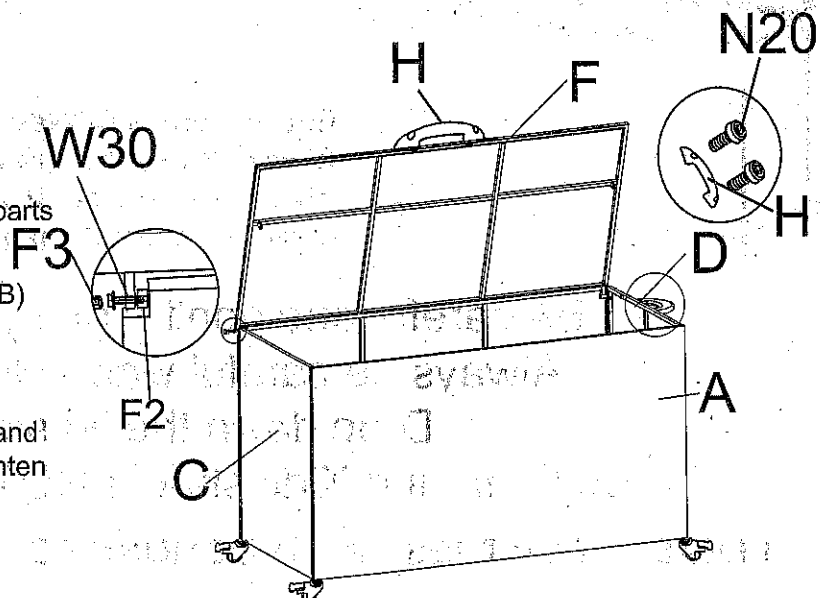

## Step Five

Attach the another side of the Pneumatic Rod to the Side Panel (C) and Side Panel (D) using Washers (F2), Bolts (W30) and Bolt Head Caps (F3).

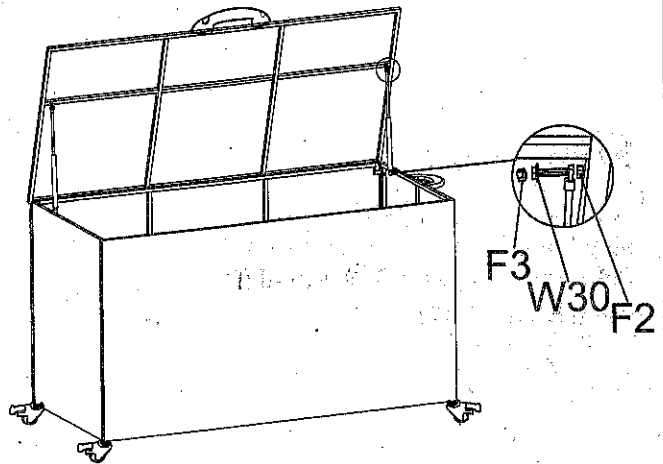

## Step Six

Attach the Lining (G) to the above partly-assembled parts by Velcro Belt.

Your Storage Box is now ready for use.

### Note:

Always Fasten the Zipper in the Lining.

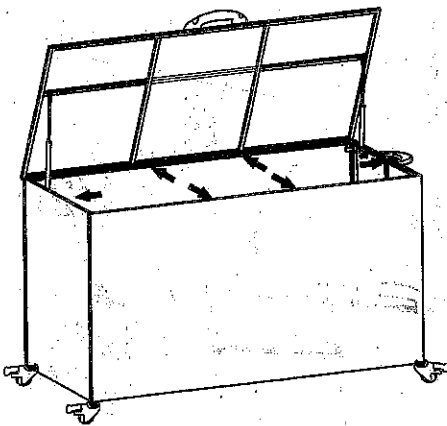
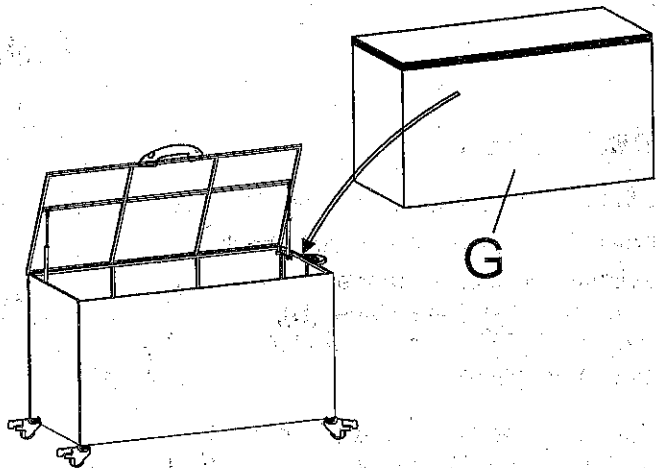

**Note: There is Brakes on the Castors.  
Always Press the Brakes to stop the Box.  
Always release the Brakes before moving the Box  
to avoid castor damage.**

Be careful and don't pinch your fingers.

Always be careful when close the lid.

Drop down the lid slowly.

Children and Kids should NOT use this box.

**PLEASE KEEP THESE INSTRUCTIONS FOR FUTURE REFERENCE**

[www.royalcraft.co.uk](http://www.royalcraft.co.uk)