

# KOBLE

[www.koblesigns.com](http://www.koblesigns.com)

## Vortex Upholstered Gaming Chair



Thank you for purchasing the Gaming Chair. In order to make the best use of this product and to use it safely, please read the manual carefully before use and keep it for future reference.

STOCK Ref.: Black & White - DGCVORW / Black & Grey - DGCVORG  
Imported By: Koble Designs (Justwise Group Ltd). CB11 3AP.



APPROXIMATE 1 HOUR  
ASSEMBLY TIME



## Safety and Care Advice

### Important – Please read these instructions fully before starting assembly

Check you have all the components and tools listed on pages 2, 3 and 4.

Remove all fittings from the plastic bags and separate them into their groups.

Keep children and animals away from the work area, small parts could choke if swallowed.

Make sure you have enough space to layout the parts before starting.

Assemble the item as close to its final position (in the same room) as possible.

Assemble on a soft level surface to avoid damaging the unit or your floor.

Assembly requires 2 people.

Do not fully tighten bolts until the whole bed is assembled. Do not overtighten the nuts to avoid causing damage to the threads.



We do not recommend the use of power drill/drivers **for inserting screws,**

as this could damage the unit. Only use hand screwdrivers and Allen keys.

Dispose of all packaging carefully and responsibly.

### Cleaning Guidance

Minor stains and spillages should be removed immediately from cushion fabric, by wiping over lightly with a damp cloth and mild soapy water.

Light marking can also be removed using this method.

To remove more stubborn stains or marking, a good quality proprietary domestic fabric cleaner can be used, although it should first be tested on an inconspicuous area of the fabric.

### Care and maintenance

From time to time check that there are no loose screws on this unit.

This product should not be discarded with household waste. Take to your local authority waste disposal centre.

# Components-Parts

Please check you have all the parts listed below

1

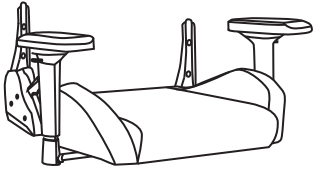

Seat Pad  
QTY 1

2

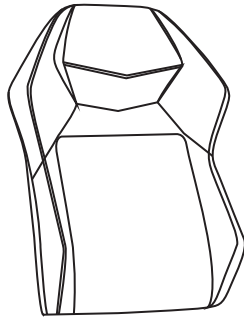

Backrest  
QTY 1

3

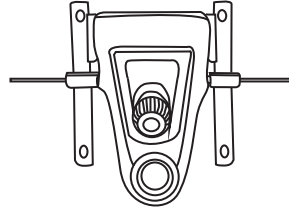

Seat Base  
QTY 1

4

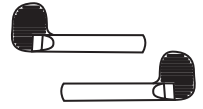

Lever  
QTY 2

5

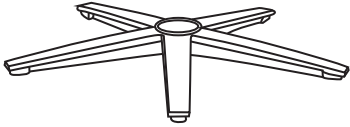

Base  
QTY 1

6



Piston  
QTY 1

7

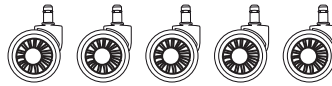

Castors  
QTY 5

8

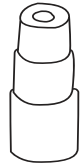

Plastic Cover  
QTY 1

For missing or damaged parts, call our Customer Helpline: 01799 513466 or email [help@koble designs.com](mailto:help@koble designs.com)

# Fittings

Please check you have all the parts listed below

**A**

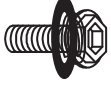

M8X25mm  
Bolt  
QTY 8

**B**

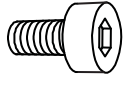

M5X10mm  
Allen Screw  
QTY 2

**C**

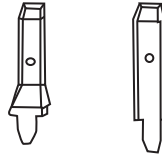

Plastic Cover  
QTY 1 Pair

**D**



Allen Key  
QTY 1

**E**



Plastic Cover  
QTY 2

For missing or damaged parts, call our Customer Helpline: 01799 513466 or email [help@koble designs.com](mailto:help@koble designs.com)

# Assembly Steps

## Step 1

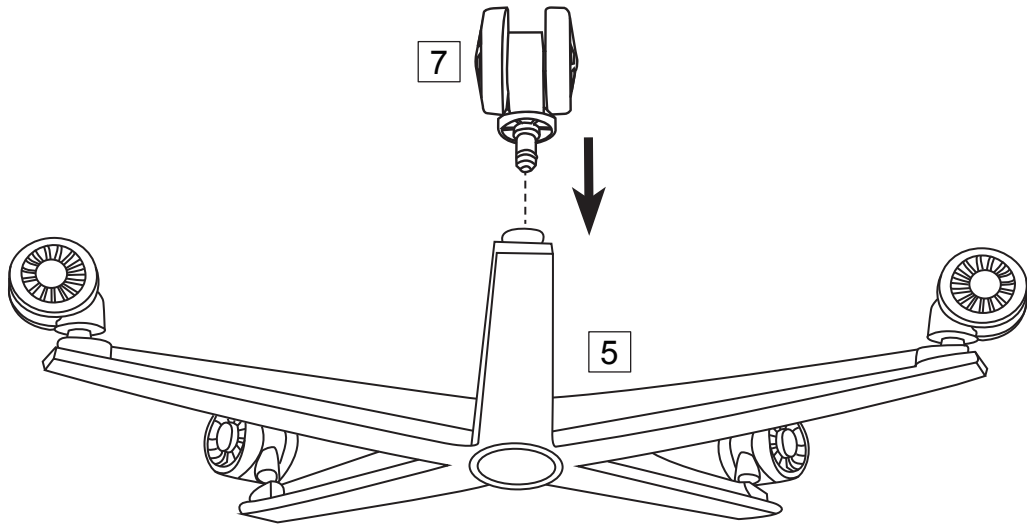

**Shown Upside Down**

## Step 2

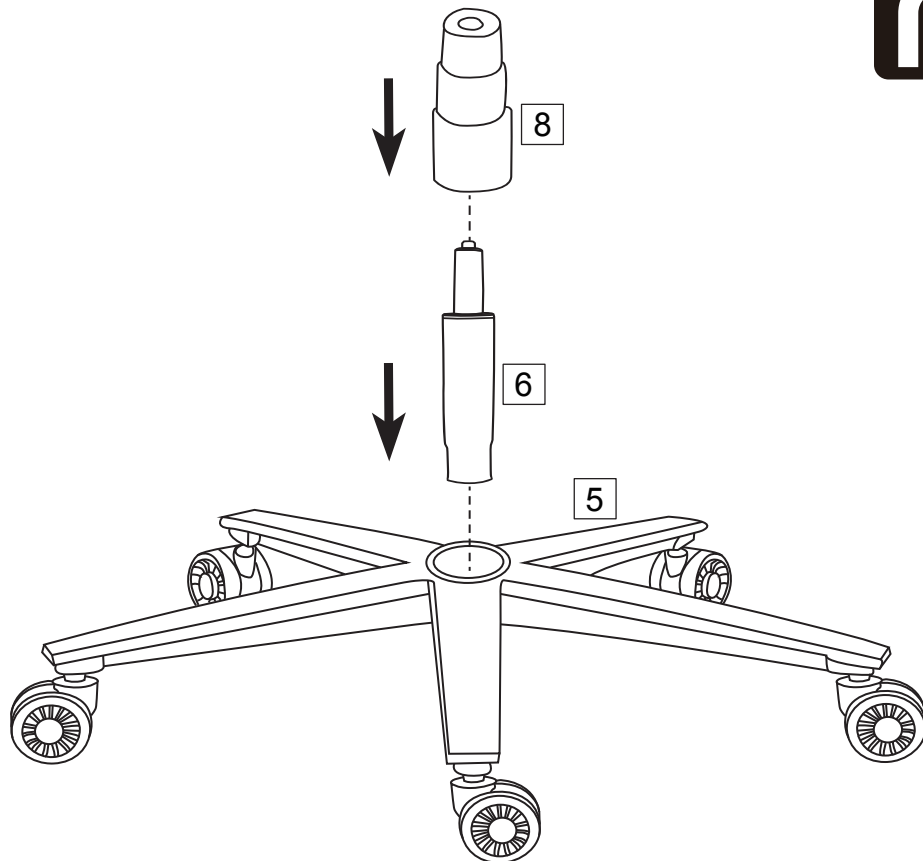

5

# Assembly Steps

## Step 3

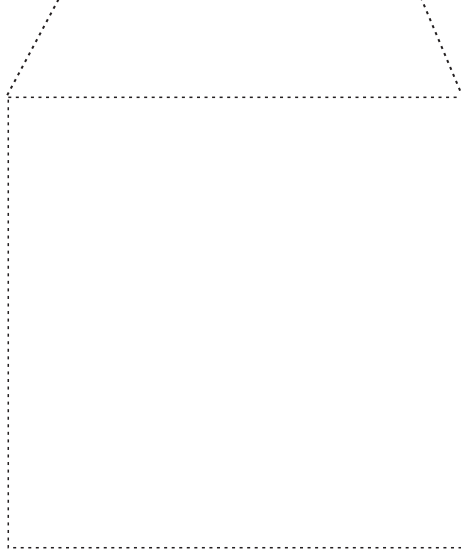
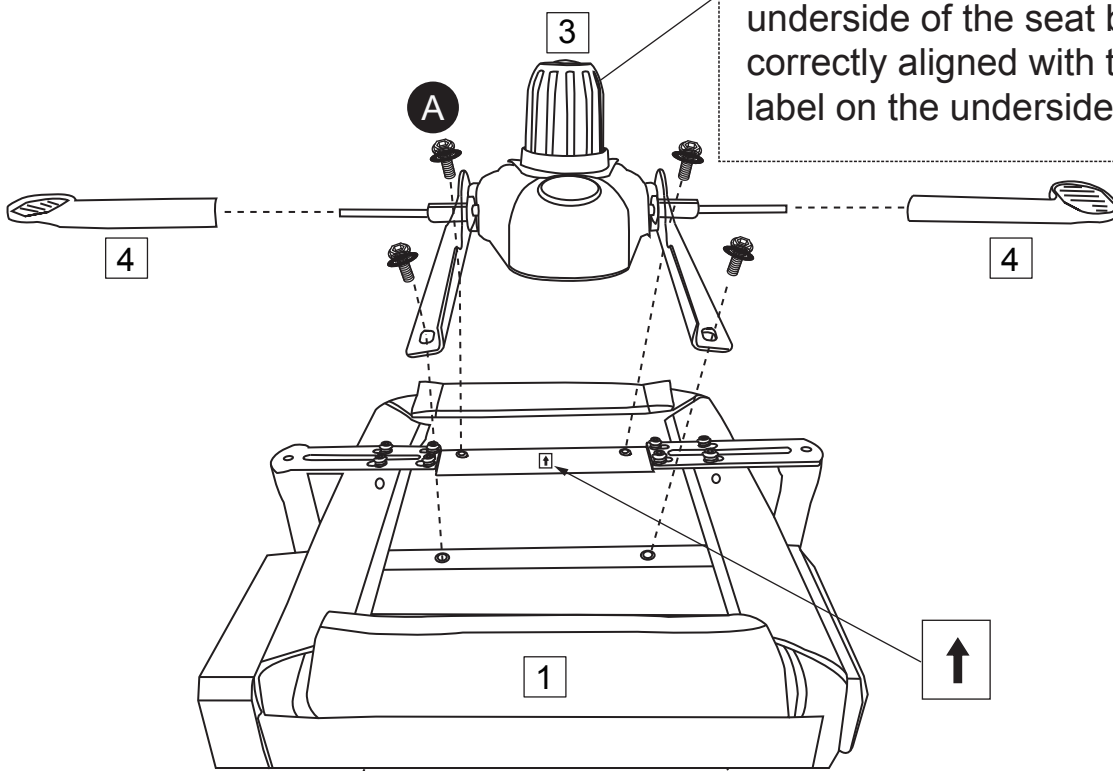
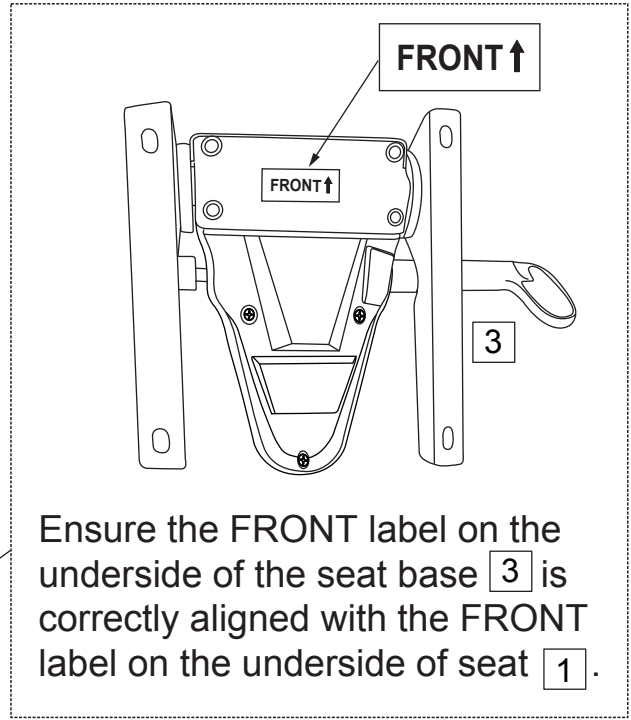

Shown Upside Down

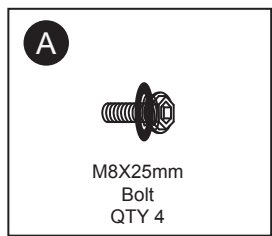

# Assembly Steps

## Step 4

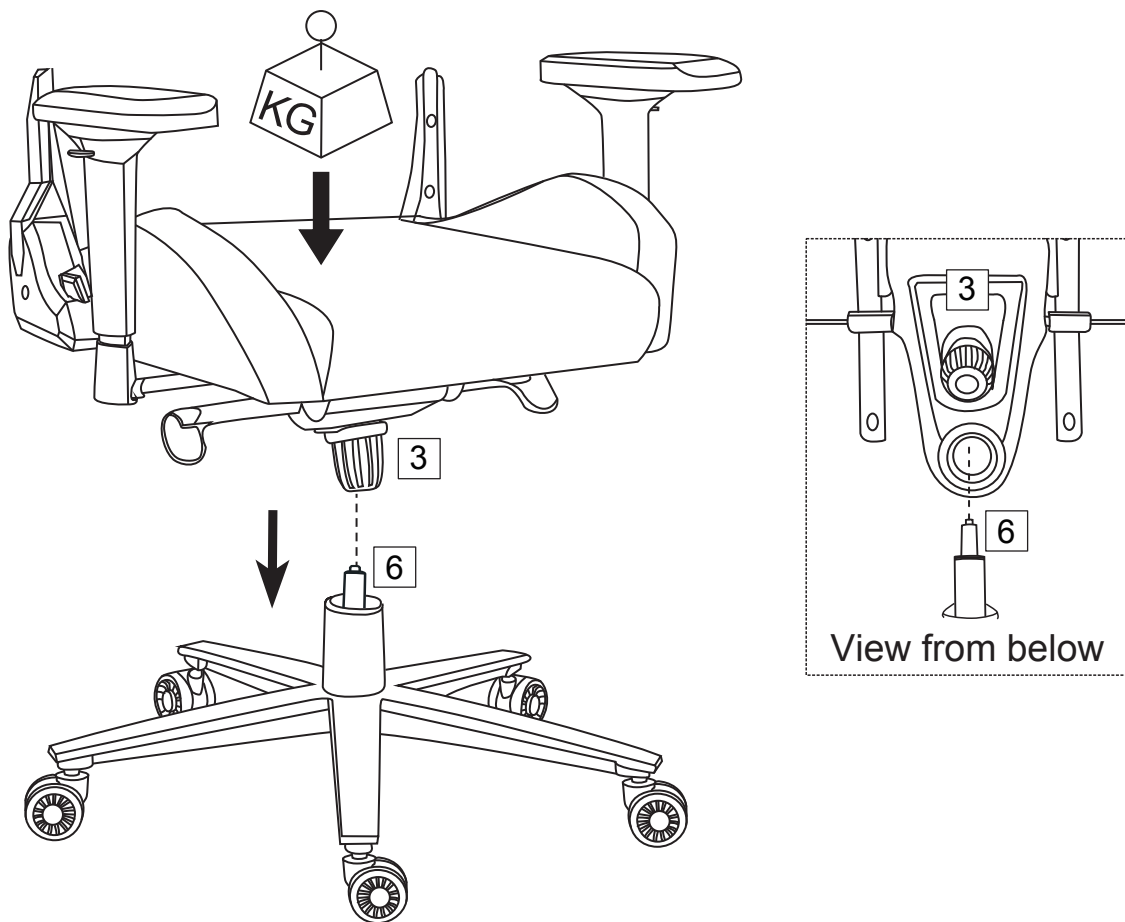

Carefully align hole in seat base **3** over piston **6** .  
Push down firmly.

# Assembly Steps

## Step 5

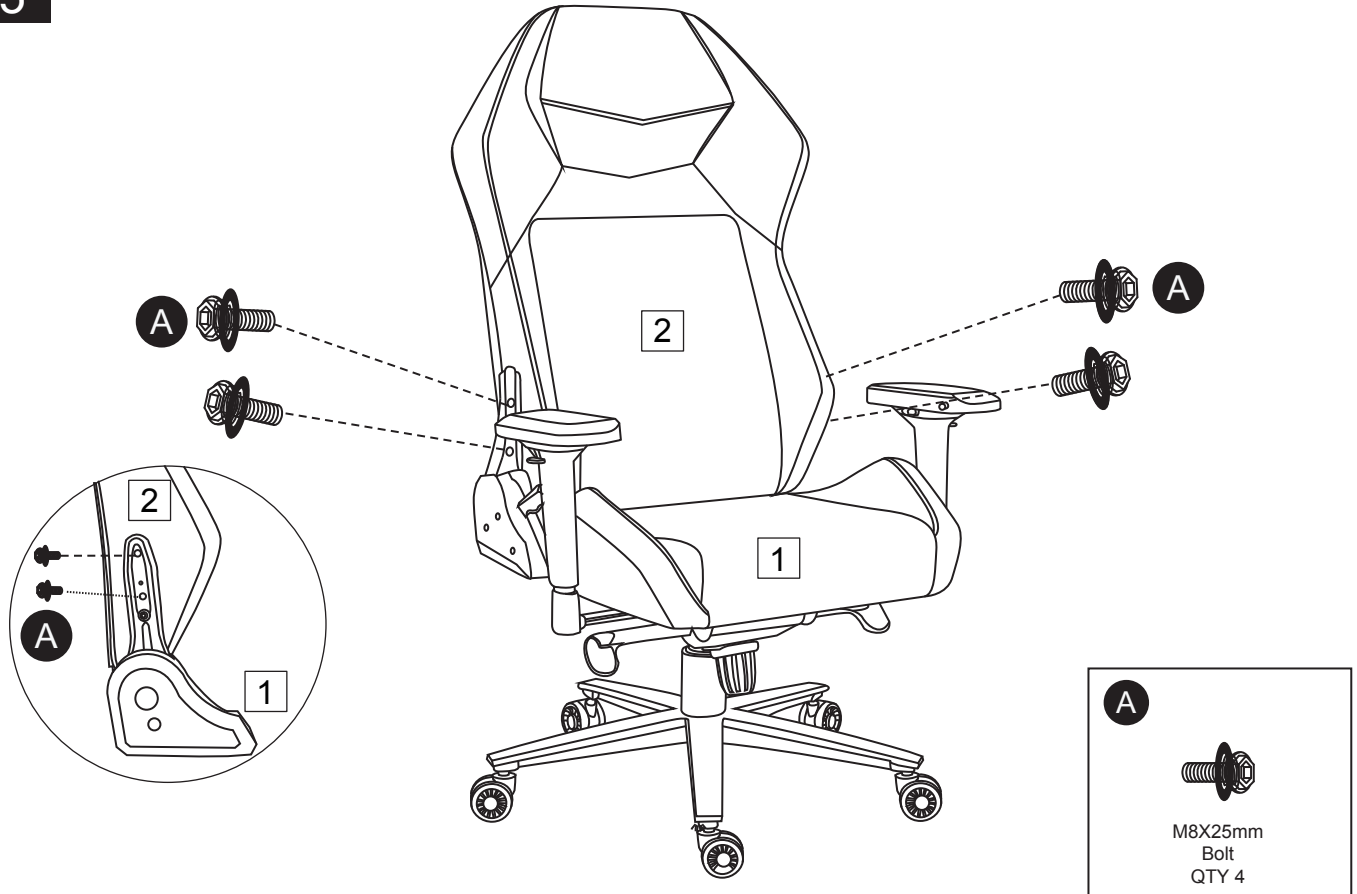

## Step 6





# Functions

## Step 7



# After Sales Support / Product Returns

## **Purchased from kobledesigns.com**

In the unlikely event that you need to return the unit because it is faulty, please follow the replacements or faulty items instructions at [www.kobledesigns.com](http://www.kobledesigns.com) website.

Should you need to request replacement parts, please contact our after sales support team at:-

Email - [CS@kobledesigns.com](mailto:CS@kobledesigns.com)

Tel: + 44 (0)1799 513 466

Address: Koble Designs, 6 The Shires, Shirehill industrial Estate, Saffron Walden, Essex, CB11 3AP

## **Purchased from other retailer**

If you purchased your product from one of our retail partners, please refer back to the retailer directly, for any customer services related issues, refunds or returns requests.

Koble designs may still be able to offer support with technical related queries.