

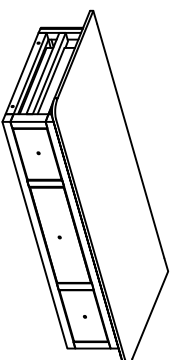

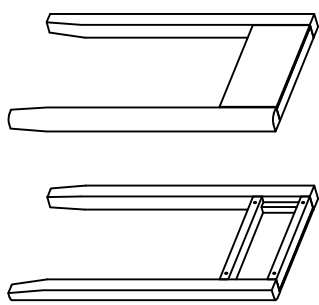





ASSEMBLY INSTRUCTION



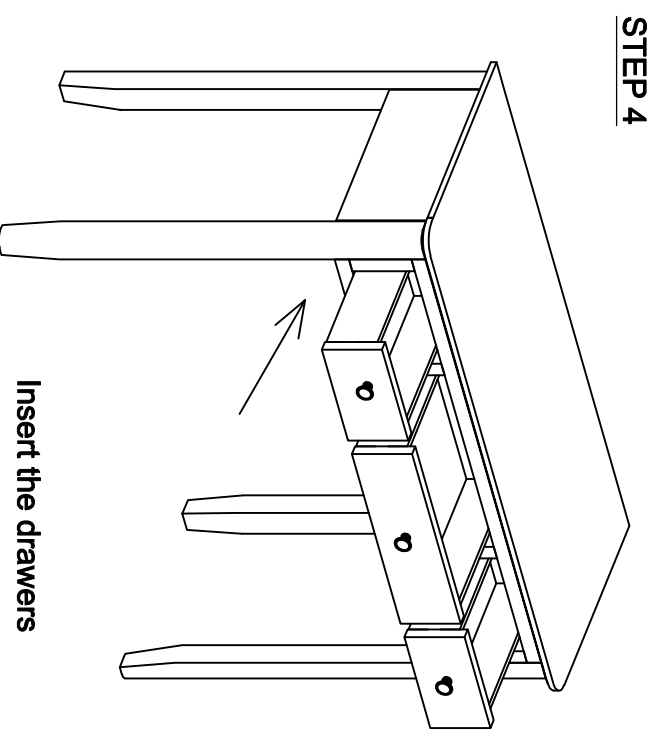
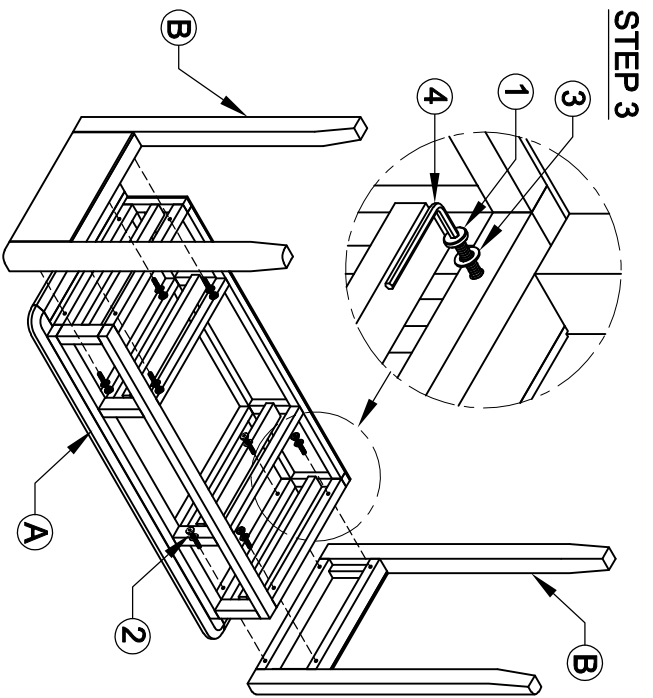
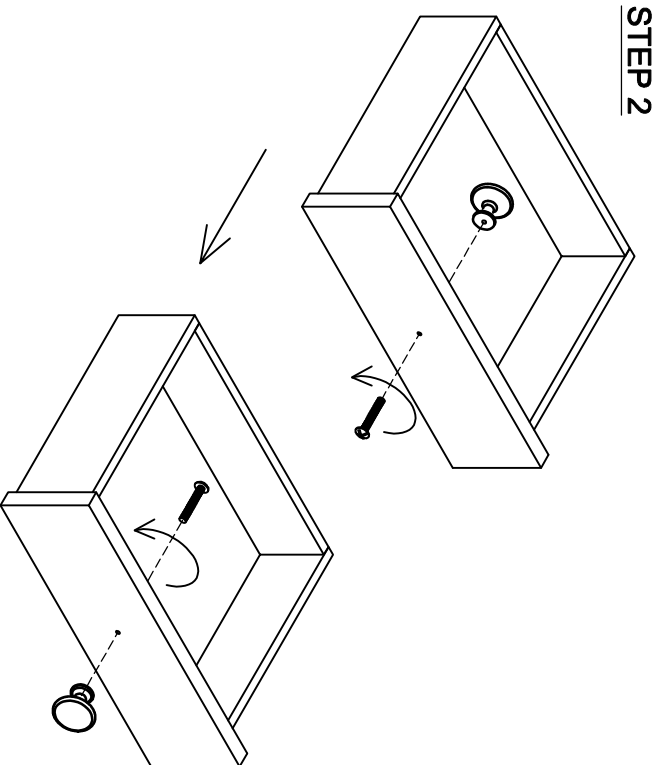
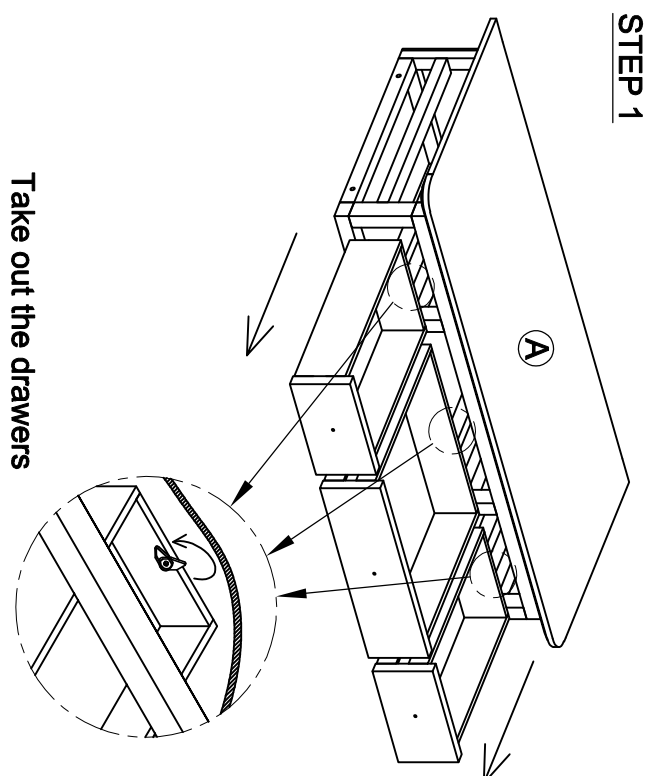

G5747-DRESSING TABLE SET - TABLE

No	Name of Component	Q.ty
A		1
B		2
No	Name of Hardware	Q.ty
1	Bolt M6 x 50 	4
2	Bolt M6 x 40 	4
3	Washer Ø7/Ø15 x 1 	8
4	Allen key K4 	1
5	Bracket 	2
6	Tie 	1
7	Screw Ø4 x 20 	2

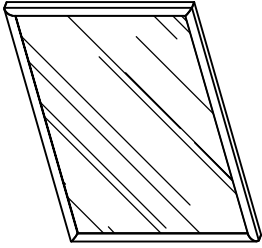
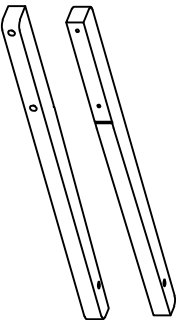
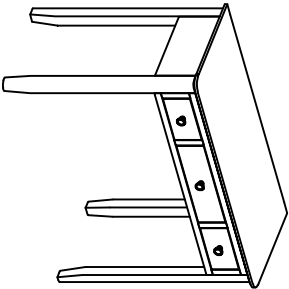

ASSEMBLY INSTRUCTION

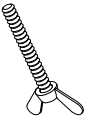
G5747 - DRESSING TABLE SET - MIRROR

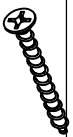
No	Name of Component	Q.ty
C		1
D		2
E		1
No	Name of Hardware	Q.ty
3	Washer Ø7/Ø15 x 1 	4
8	Bolt M6 x 50 	2
9	Screw Ø4 x 25 	4
10	Screw Ø4 x 45 	4

STEP 5

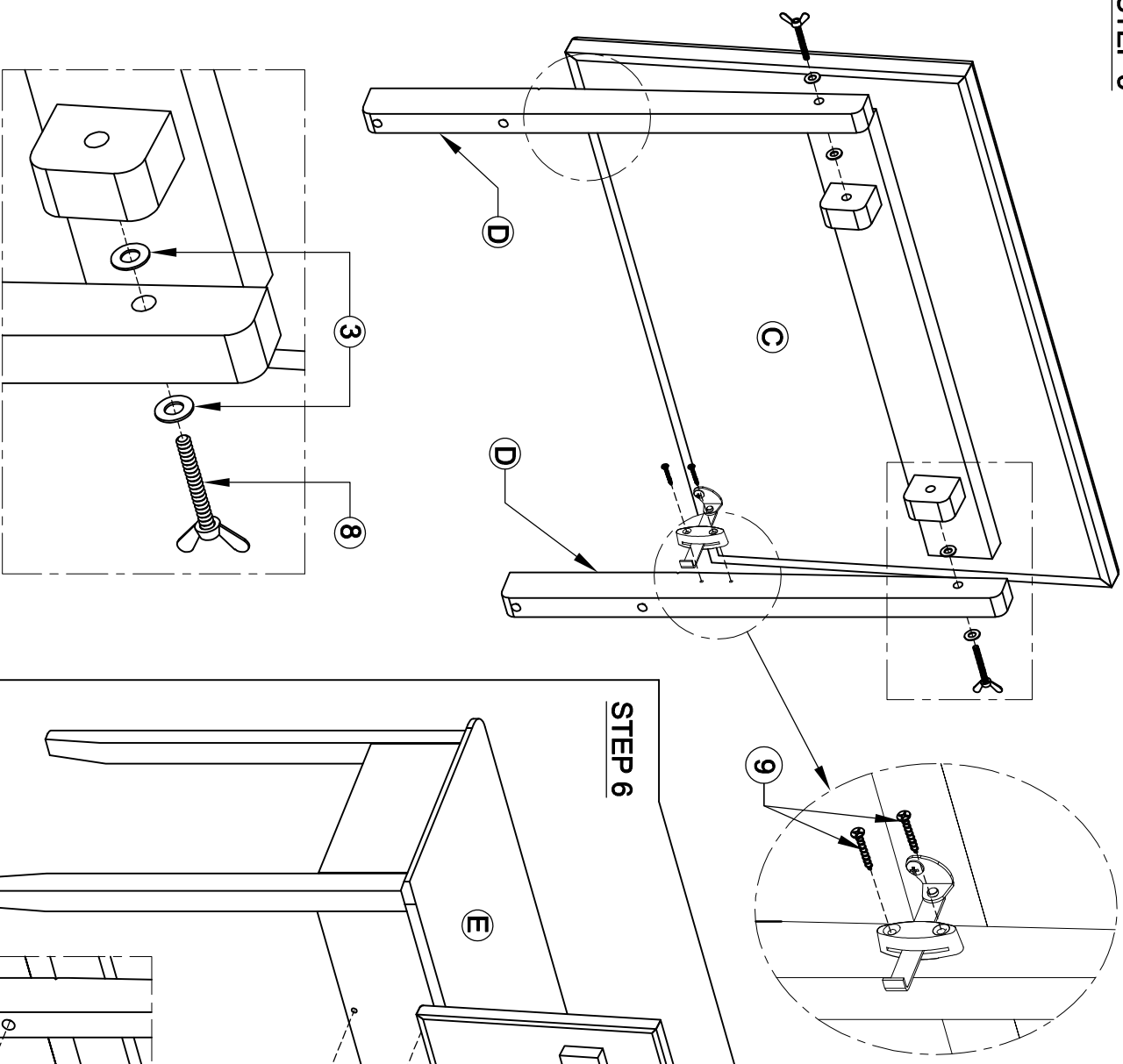

STEP 6

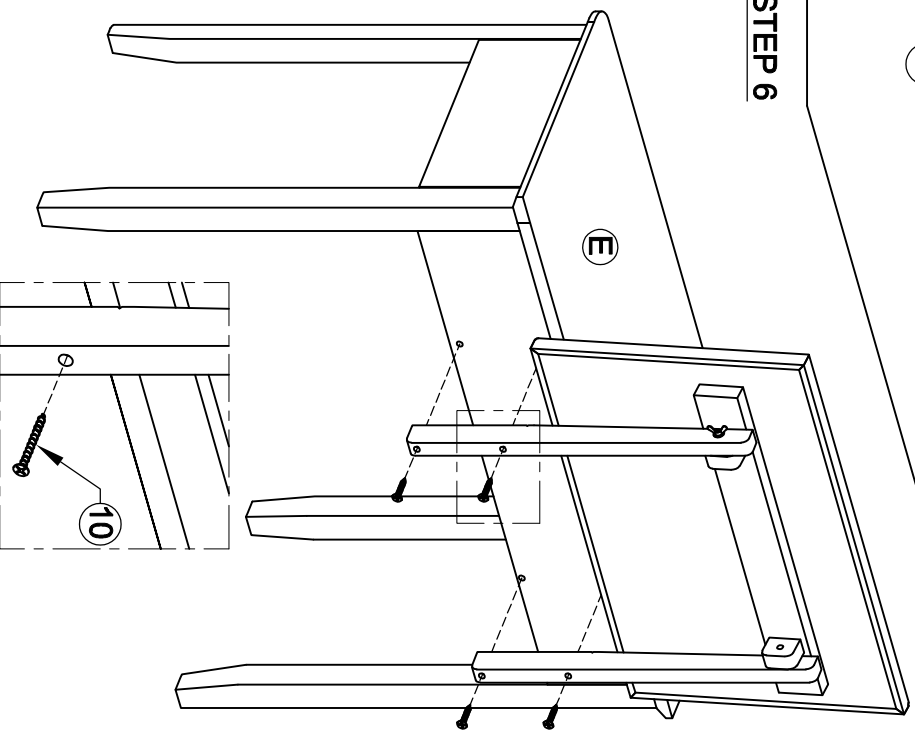

STEP 6

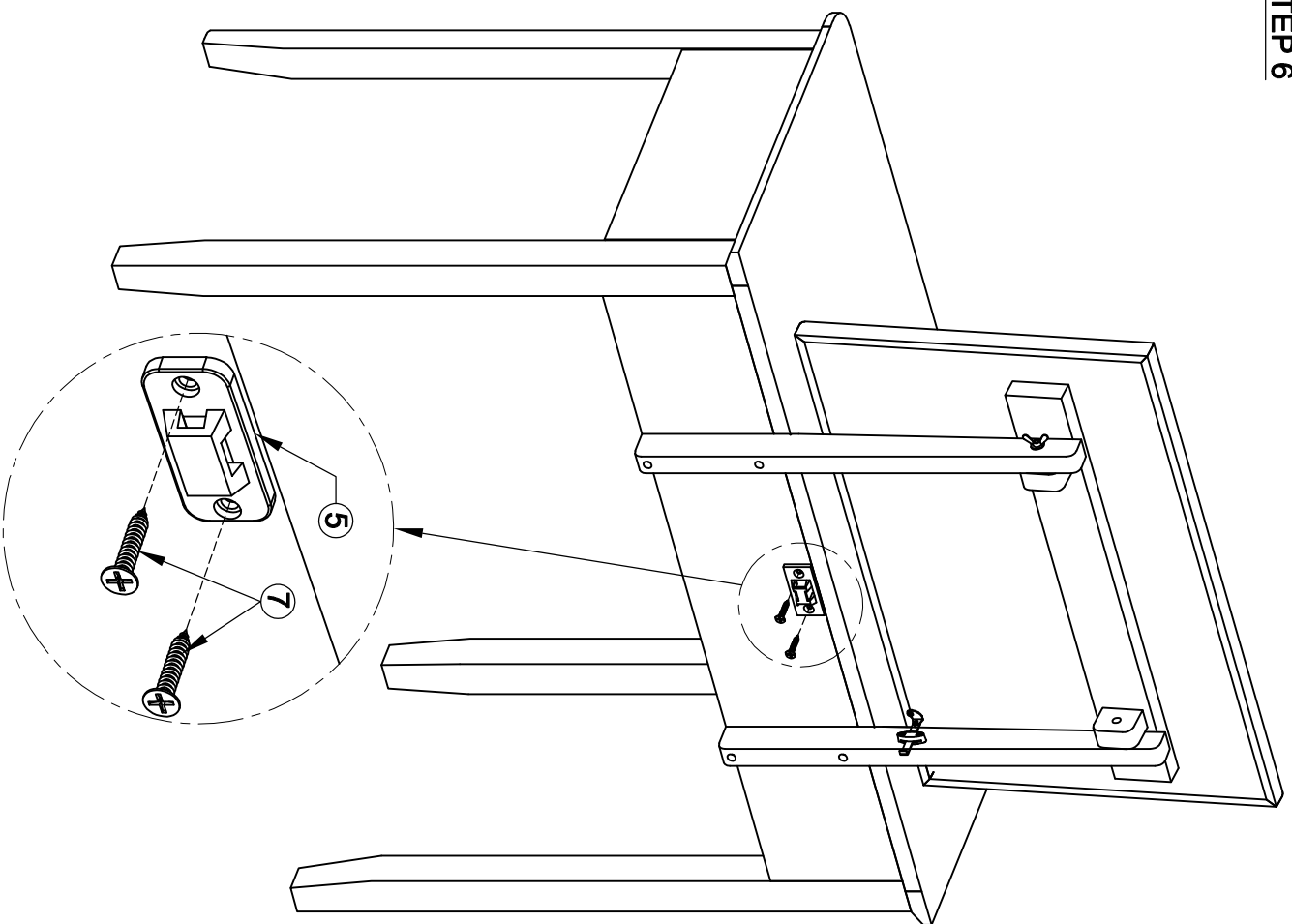



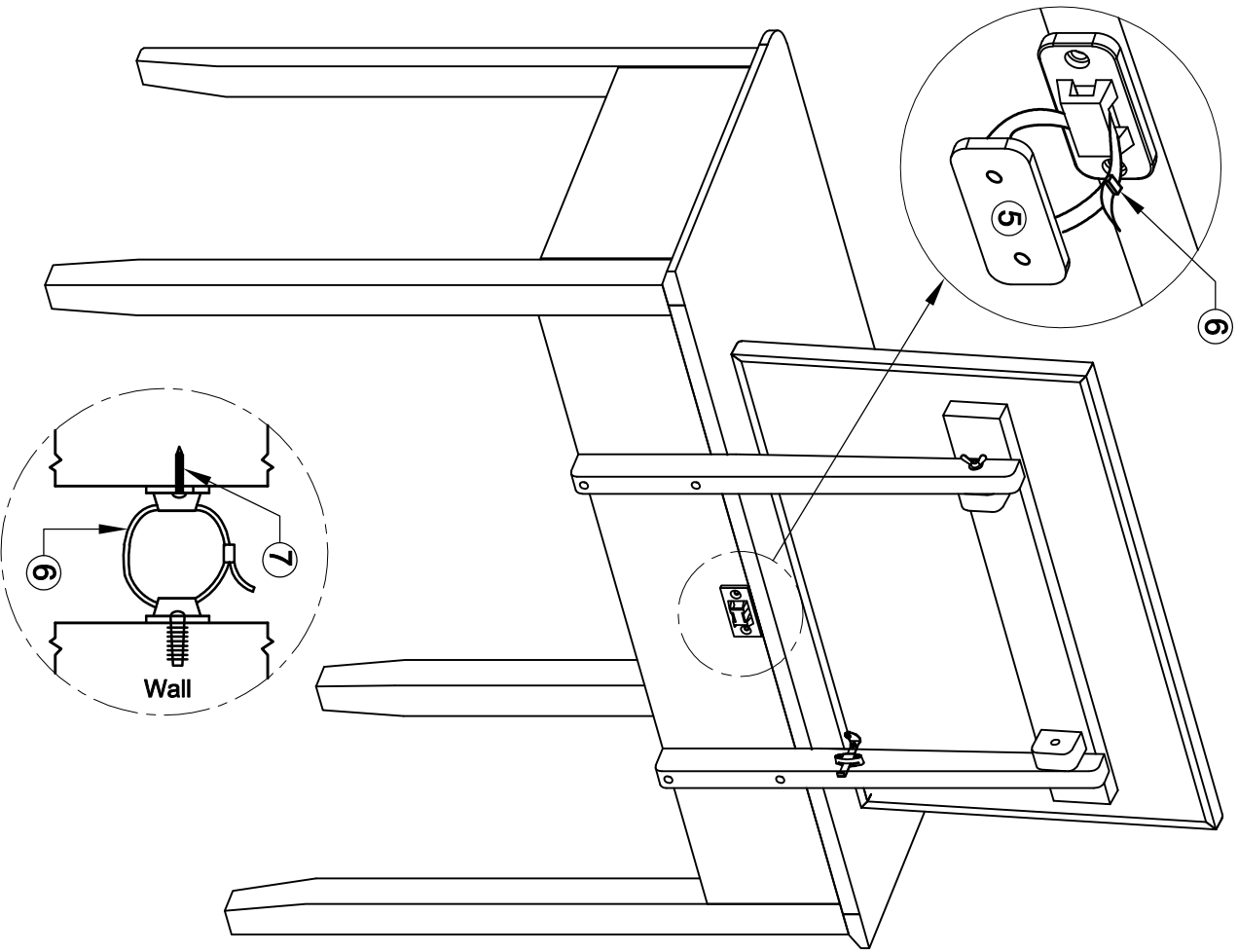

STEP 7

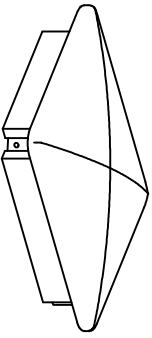
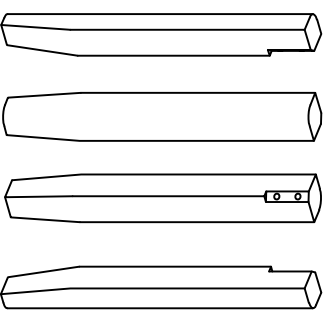

ASSEMBLY INSTRUCTION

G5747-DRESSING TABLE SET - STOOL

No	Name of Component	Q.ty
F		1
G		4
No	Name of Hardware	Q.ty
1	Bolt M6 x 50 	8
3	Washer Ø7/Ø15 x 1 	8
4	Allen key K4 	1
11	Spring washer M6 	8

STEP 8

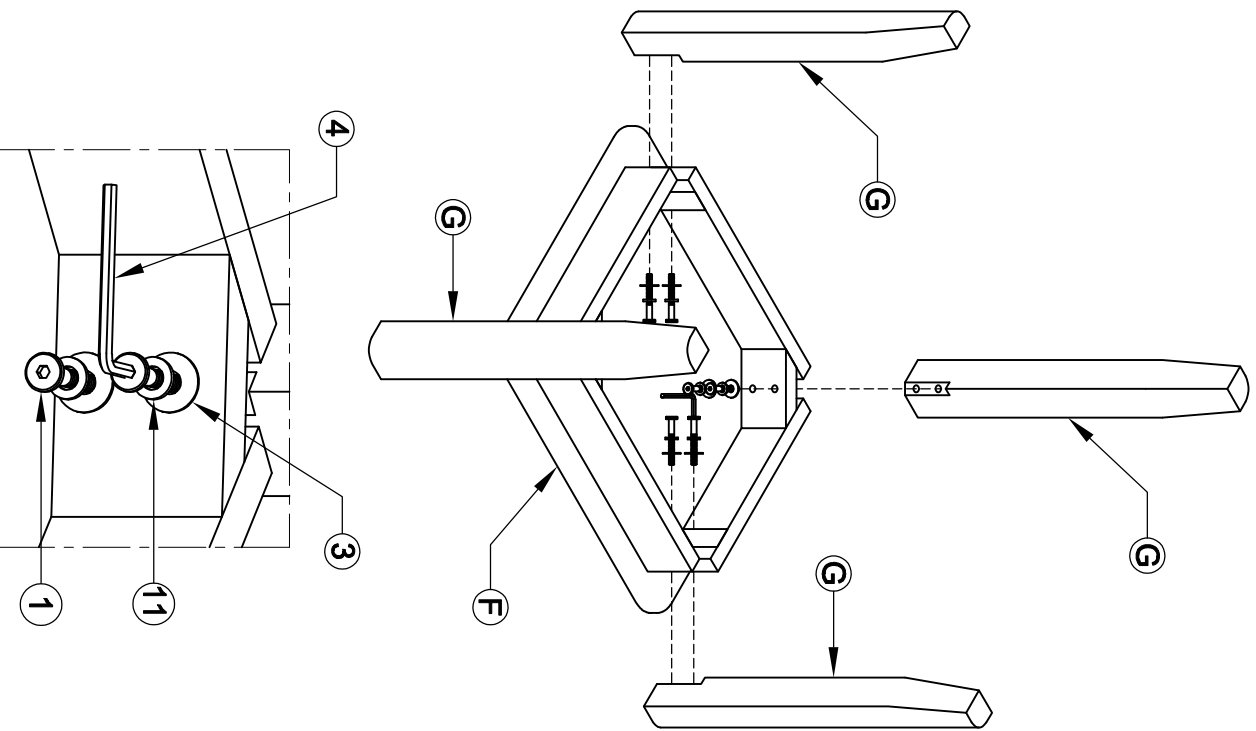

FINAL

