

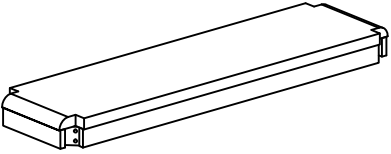

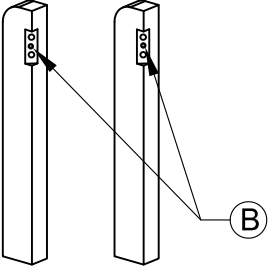

ASSEMBLY INSTRUCTION G6158 - BENCH

No.	Part name	Q'ty
A		1
B		2
C		2

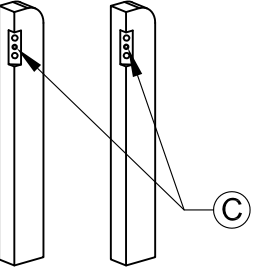
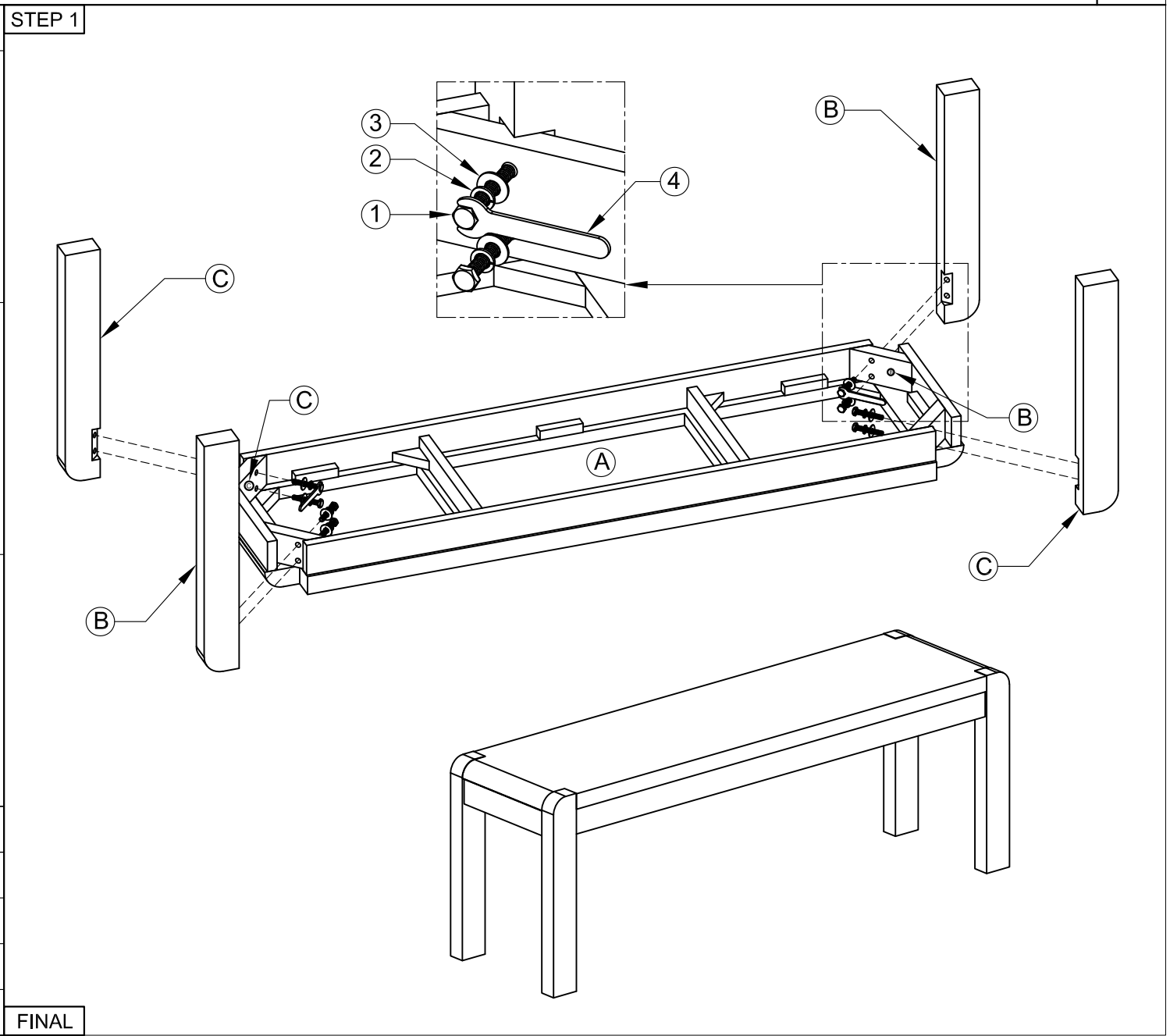

No.	Hardware name	Q'ty
1	Bolt M8x50 	8
2	Lock Washer M8 	8
3	Flat Washer M8 	8
4	Wrench 	1