

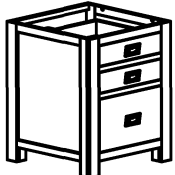

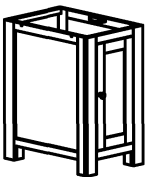

No	Name of Component	Q.ty
(A)	 Table top frame	1
(B)	 Base (left)	1
(C)	 Base (right)	1

No	Name of Hardware	Q.ty
(1)	 Bolt M6 x 40	6
(2)	 F-Screw M6 x 35	4
(3)	 Washer (ø6xø14x1.5mm)	6
(4)	 Allen key (K4)	1



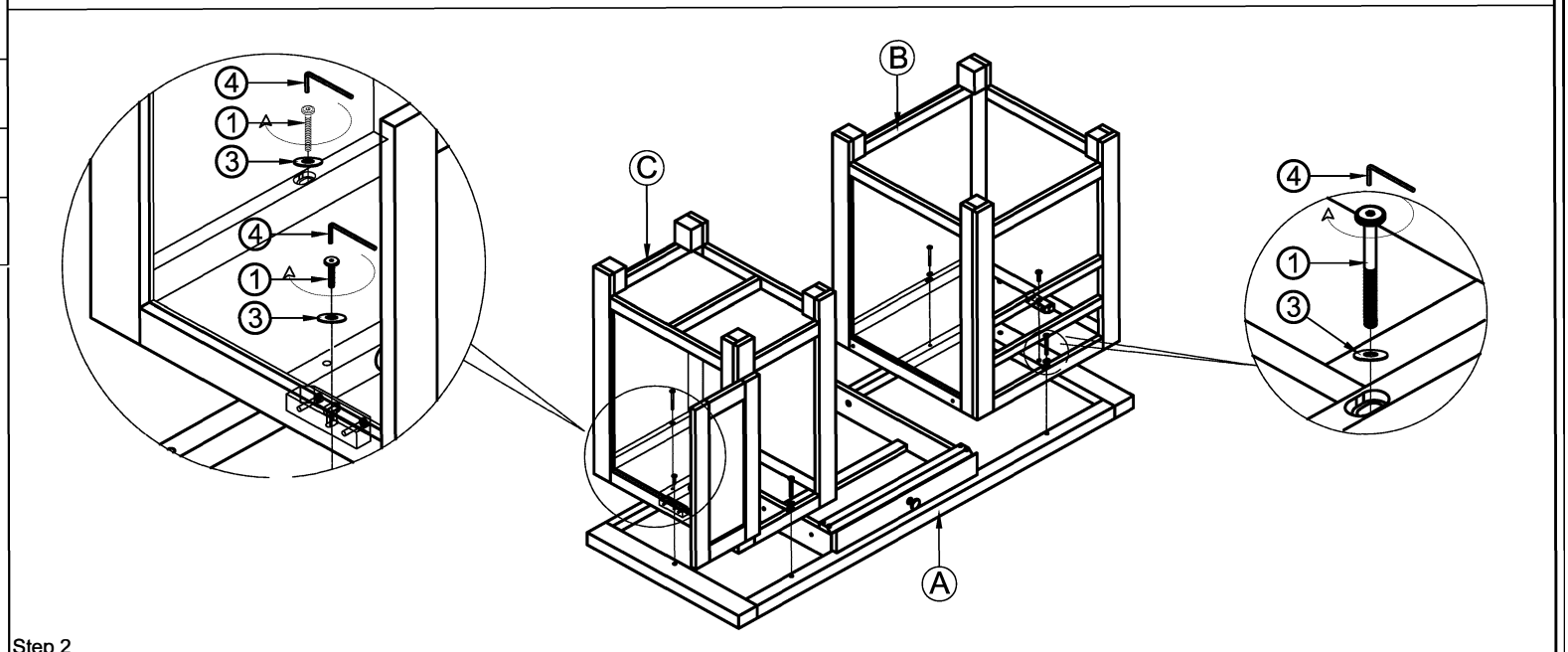
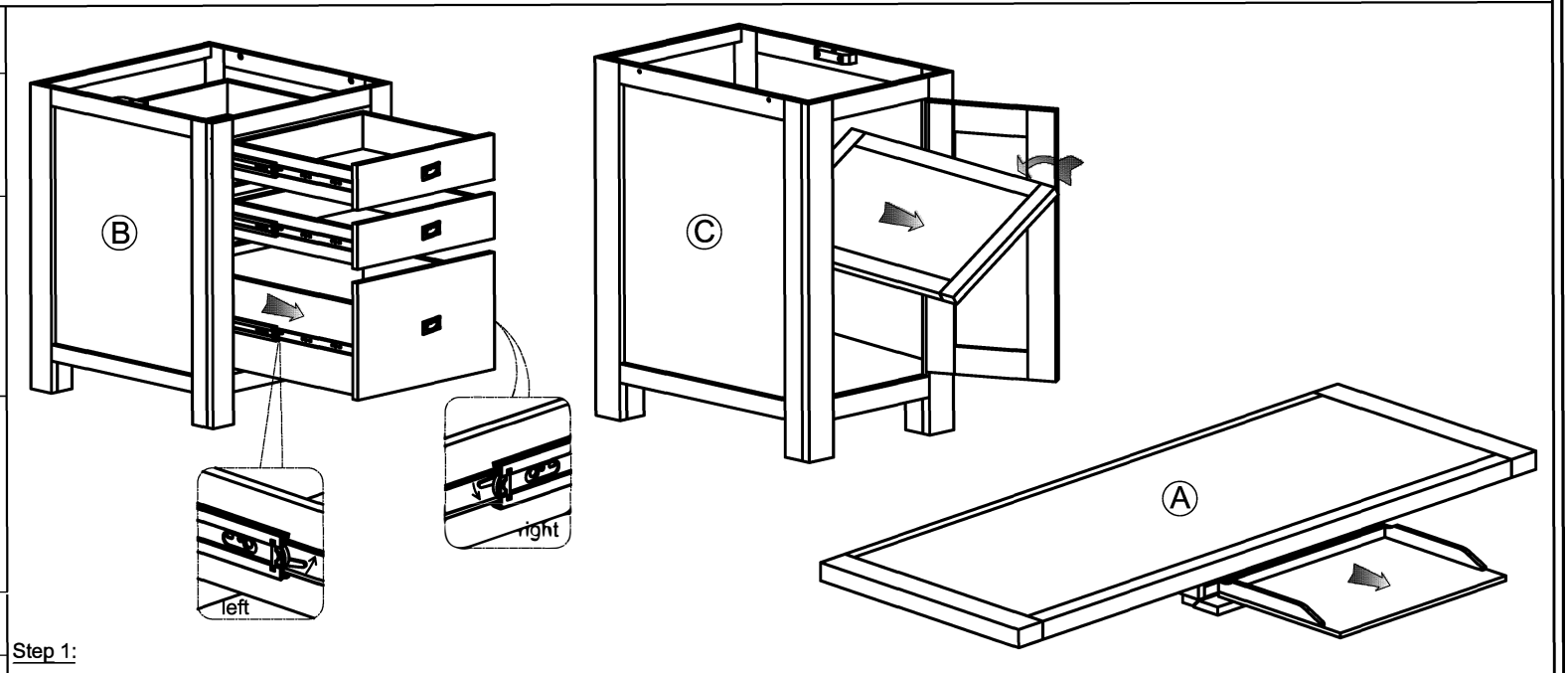
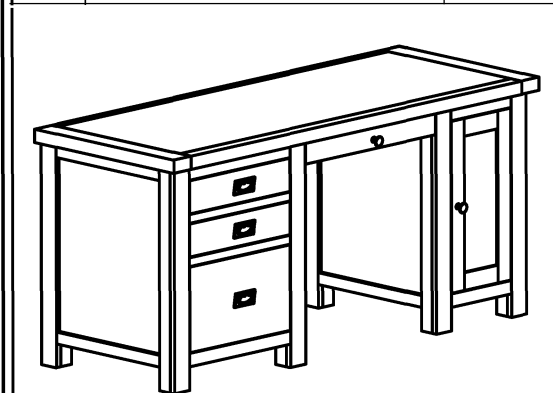
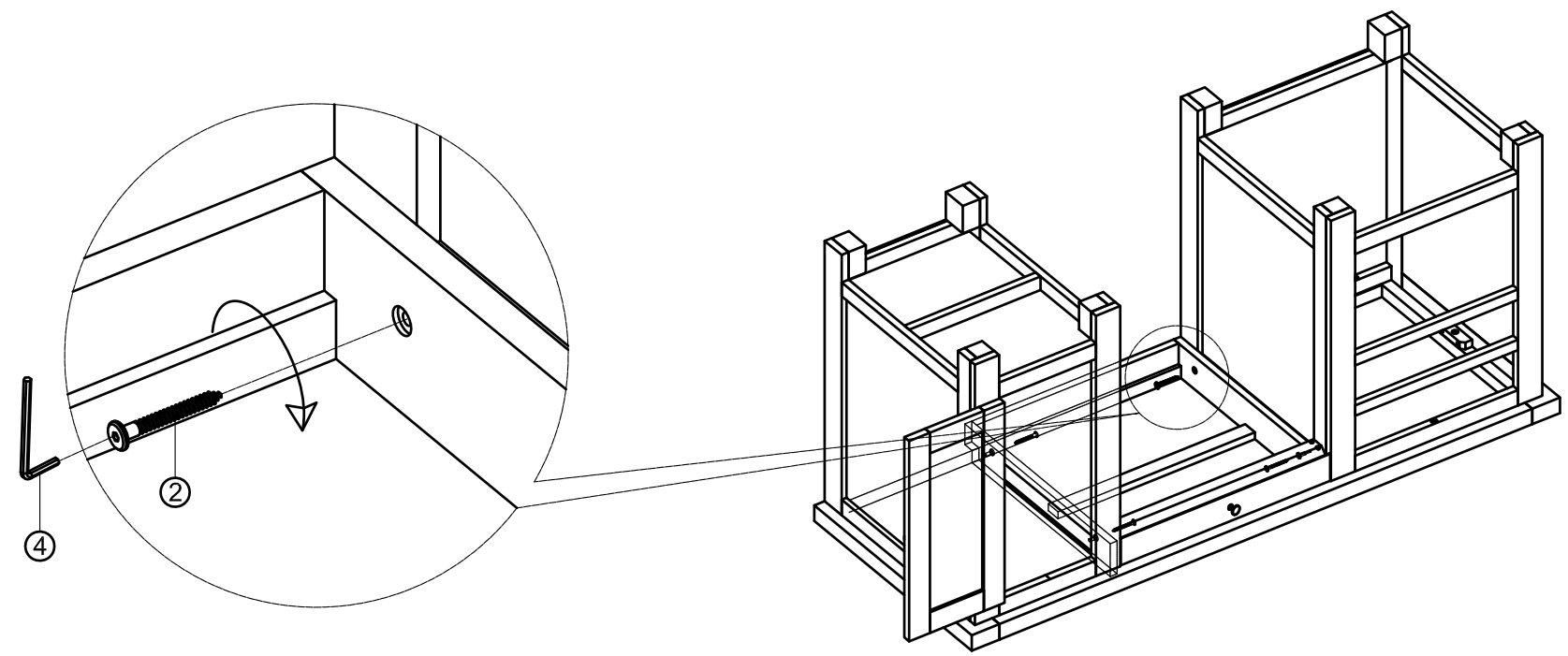

Step 3

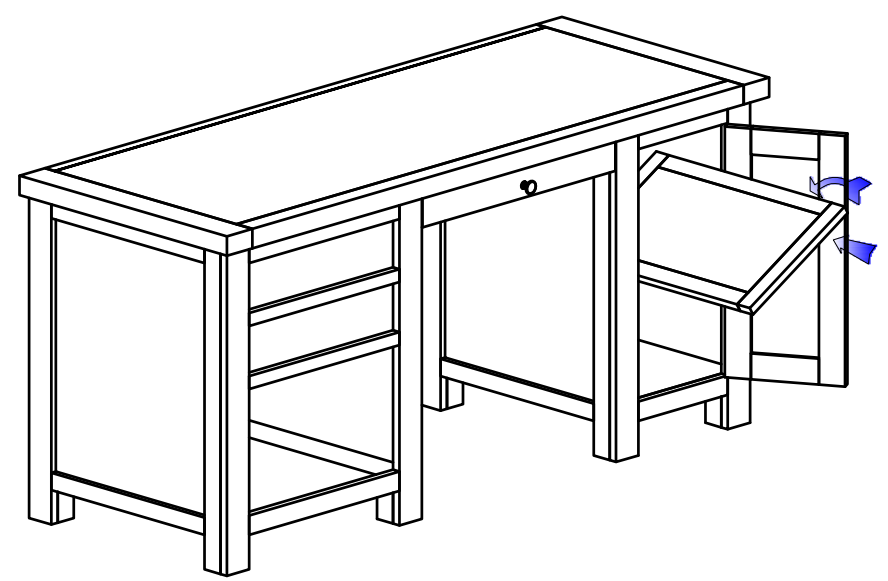

Step 4

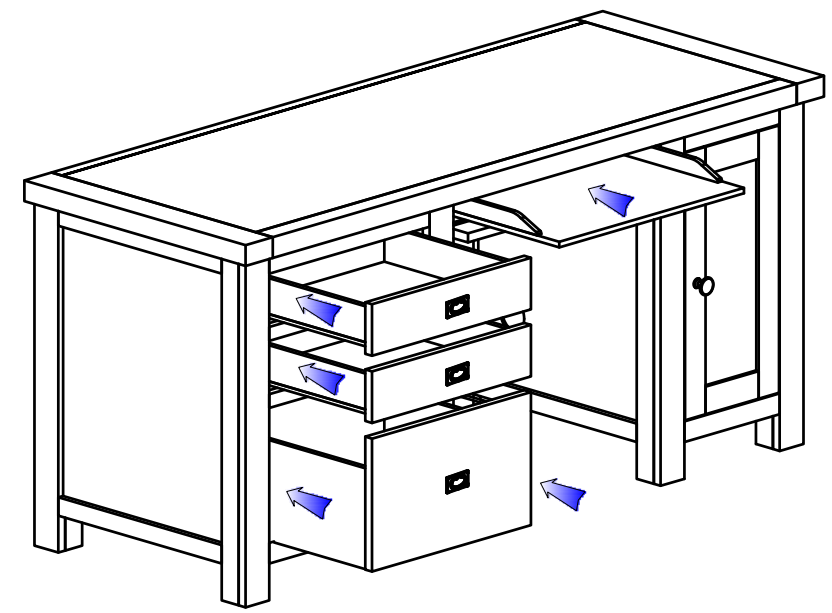

Final