

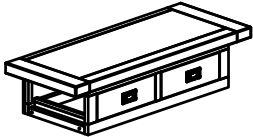

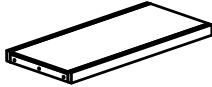

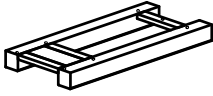



ASSEMBLY INSTRUCTION CONSOLE TABLE

No	Name of Component	Q.ty
(A)	 Table top frame	1
(B)	 Shelf	1
(C)	 Leg	2
No	Name of Hardware	Q.ty
(1)	 Bolt M6 x 40	12
(2)	 Washer Ø7/Ø15 x 1	12
(3)	 Allen key (K4)	1
(4)	 Bracket	2
(5)	 Tie	1
(6)	 Screw M4 x 20	2
(7)	 Screw M4 x 35	2



Step 1: Take out Drawers

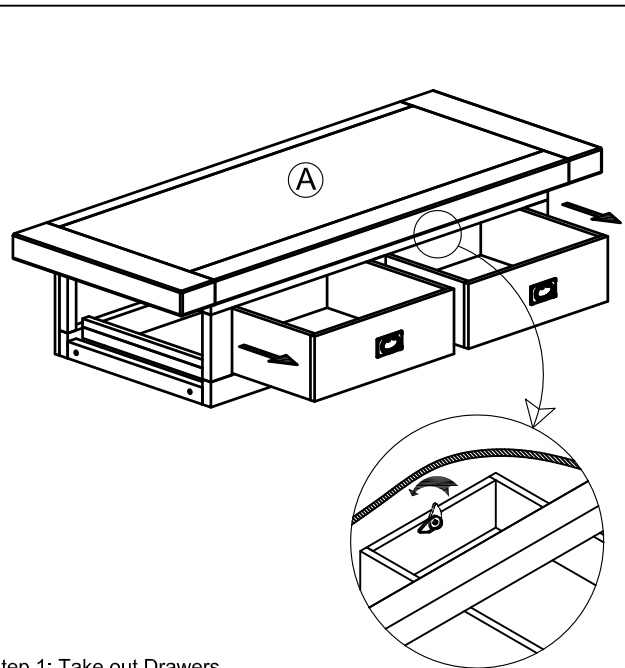
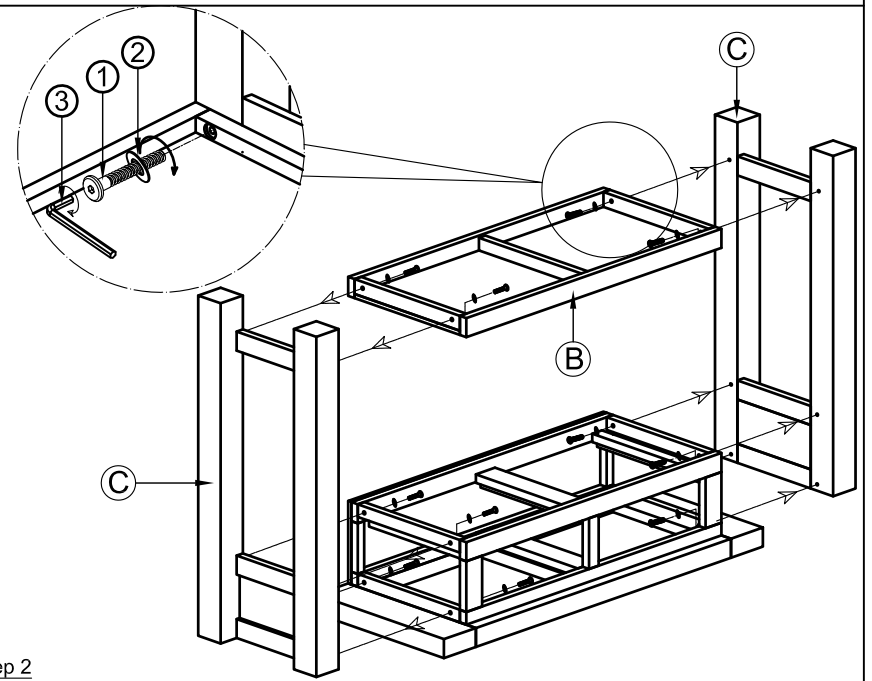

Step 2

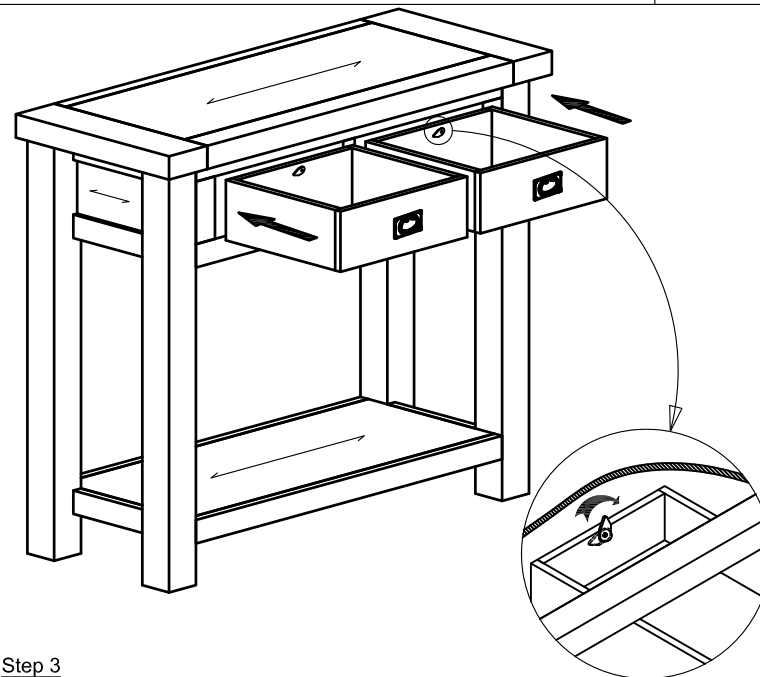

Step 3

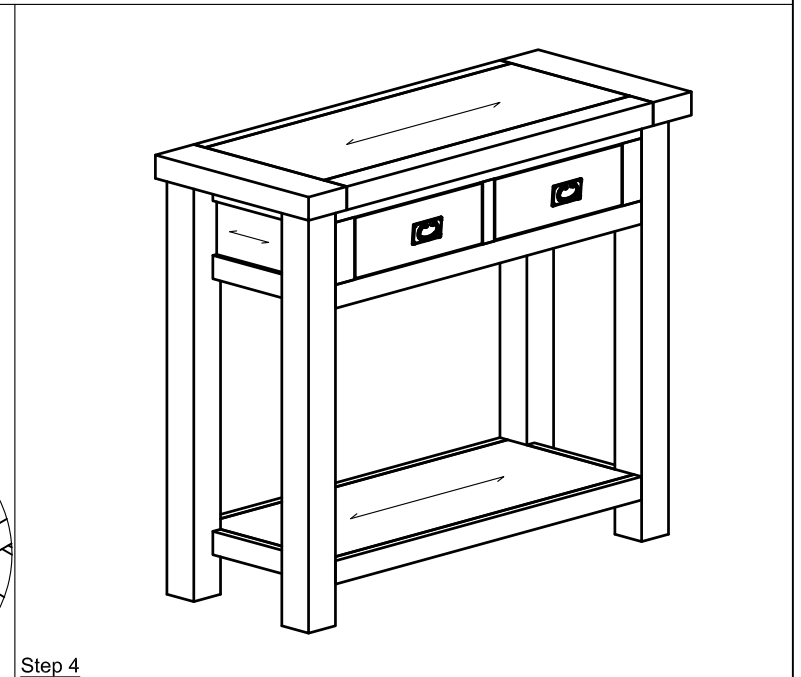

Step 4

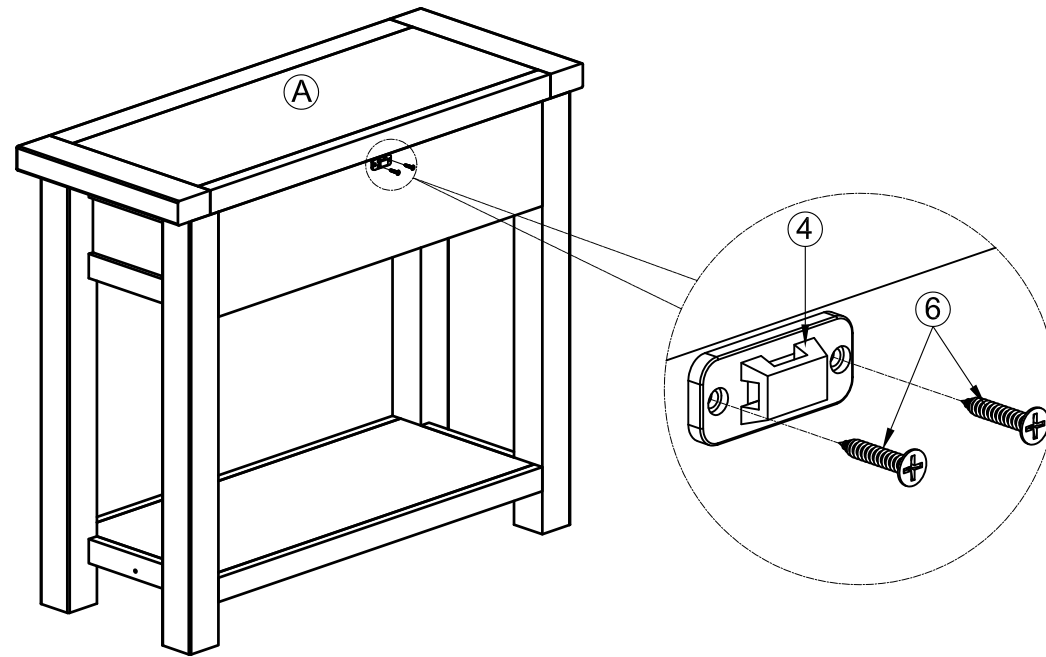

Step 5

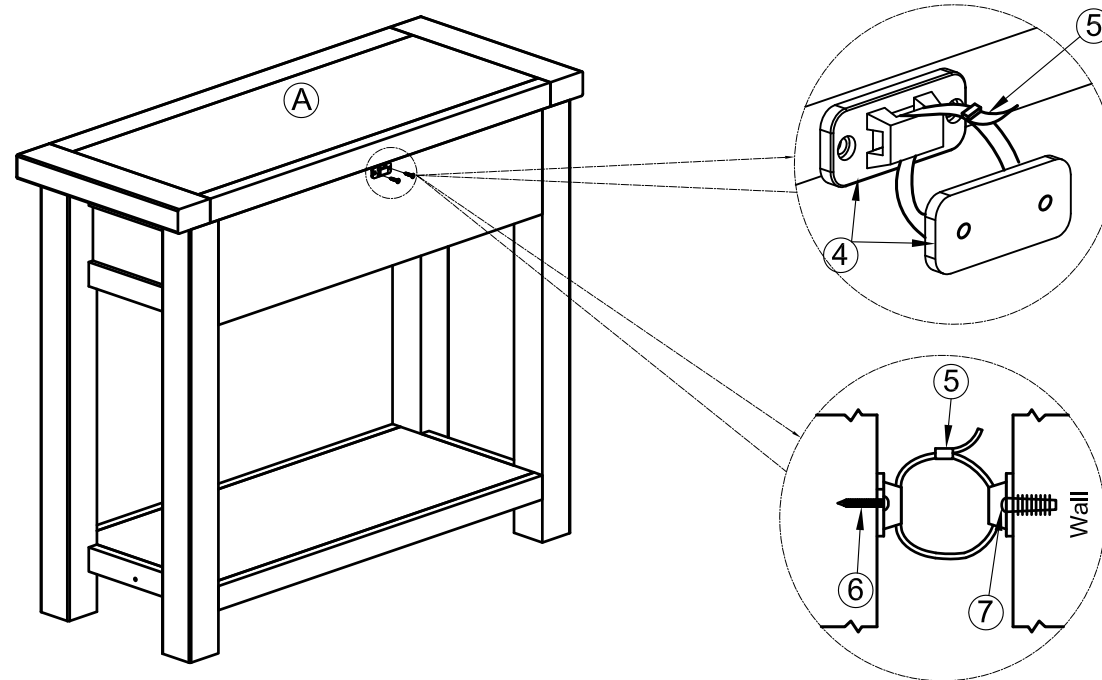

FINAL