

# 0900 Full Bed

## Assembly Instructions

KYOTO-0619

### 1 Assembled View

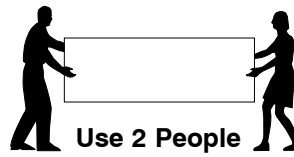
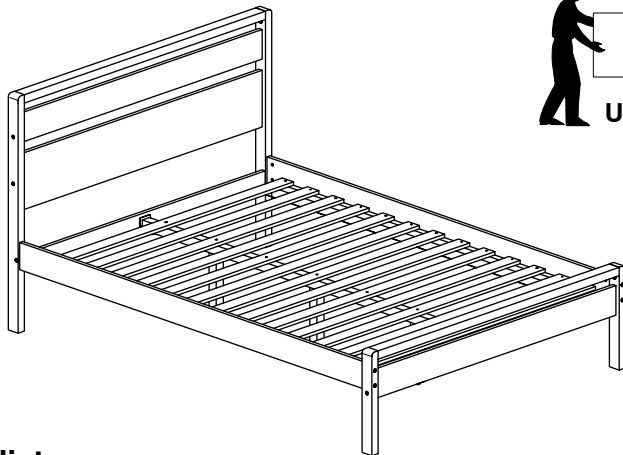

**Note:** Do not assemble using power tools. This can cause the bolts to be overtightened

### 2 Parts list

#### Parts in Box A:

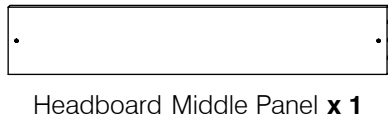
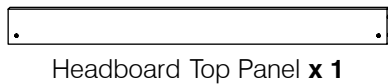

Holes for Footboard Support Bar

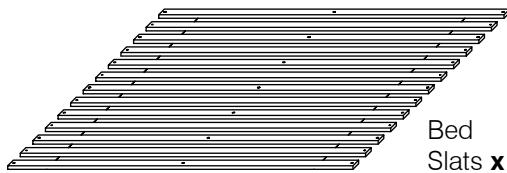
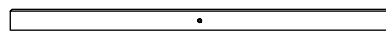

#### Parts in Box B:

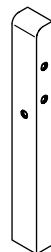
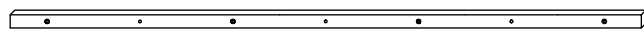
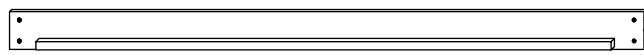

### 3 Hardware list



M6 x 100mm JCB  
x 3



M6 x 40mm JCB  
x 18



M6 x 15mm JCB  
x 12



M6 x 90mm JCB  
x 8



M6 x 30mm JCB  
x 2



Barrel Nut  
x 19



M6 x 70mm JCB  
x 8

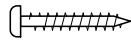

M4 x 32mm  
Wood Screws  
x 12



Wood Dowels  
(M10 x 40mm)  
x 14



'L' Bracket  
x 4

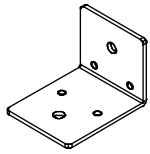

Center Rail Bracket  
x 2

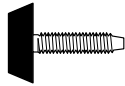

Adjustable Foot  
x 3



Allen Key  
x 1



Support Leg

Adjustable Foot

### 5 Fit the 'L' Bracket to the bottom of the Top Cap.

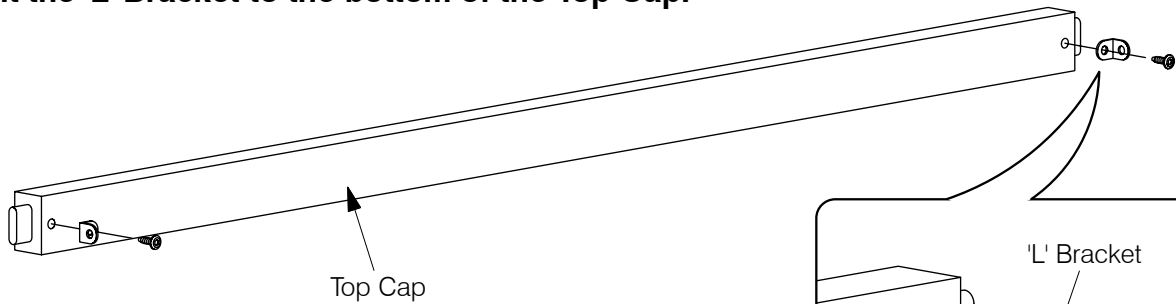

Top Cap

'L' Bracket

M6 x 15mm  
JCB

### 6 Fix the Footboard Support Bar to the Footboard Bottom Panel.

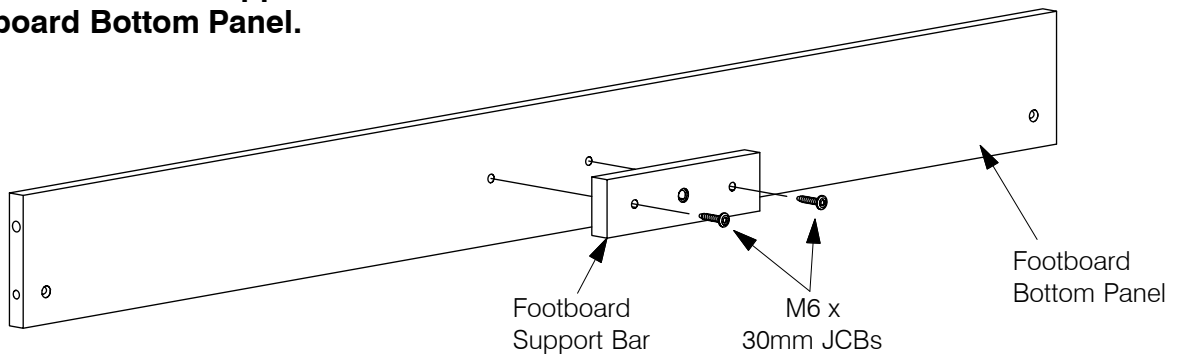

Footboard  
Support Bar

M6 x  
30mm JCBs

Footboard  
Bottom Panel

### 7 Assemble the Panels to the Footboard Post.

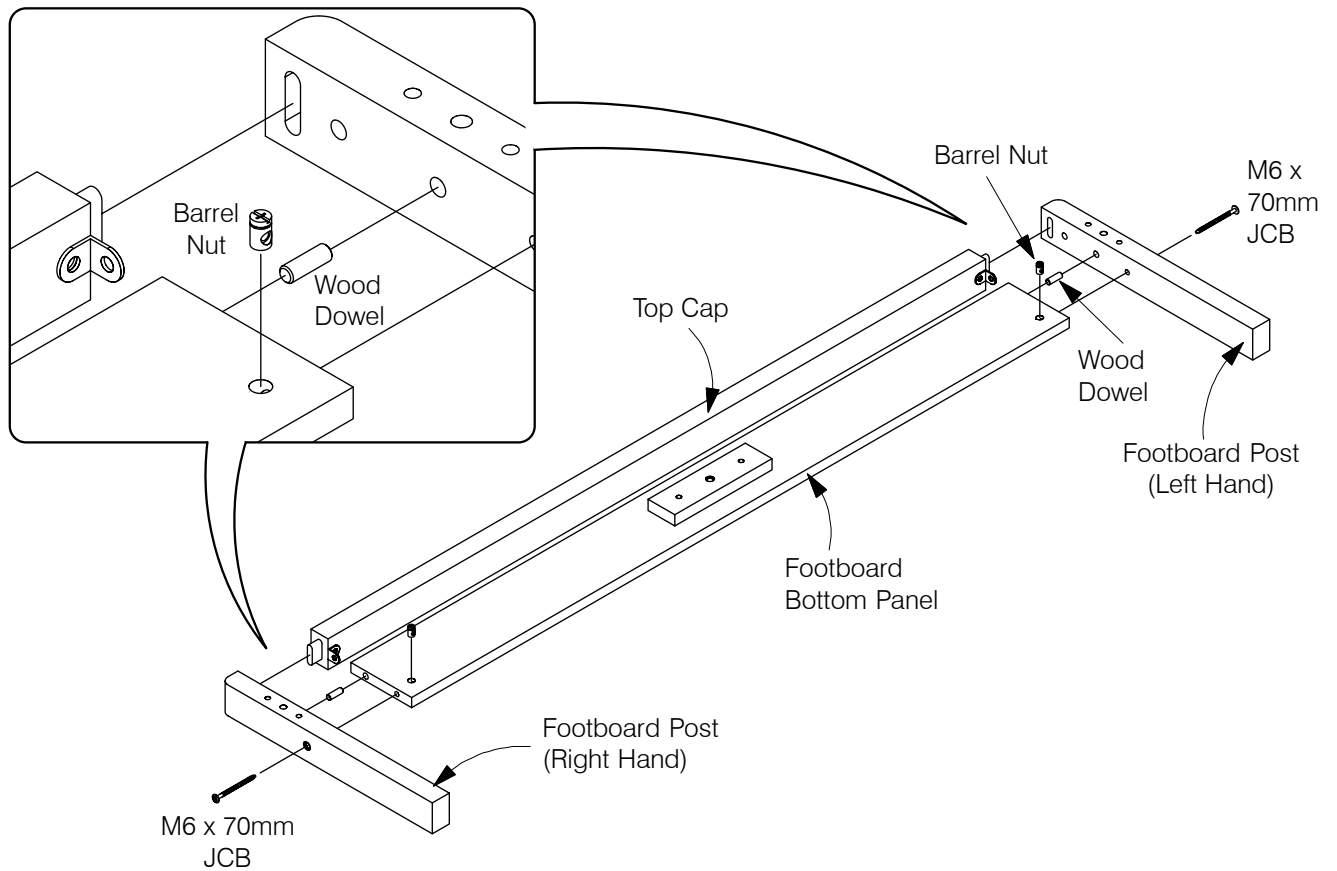

### 8 Bolt the 'L' Bracket to the Footboard Post. Fit the Center Rail Bracket to the Footboard Bottom Panel.

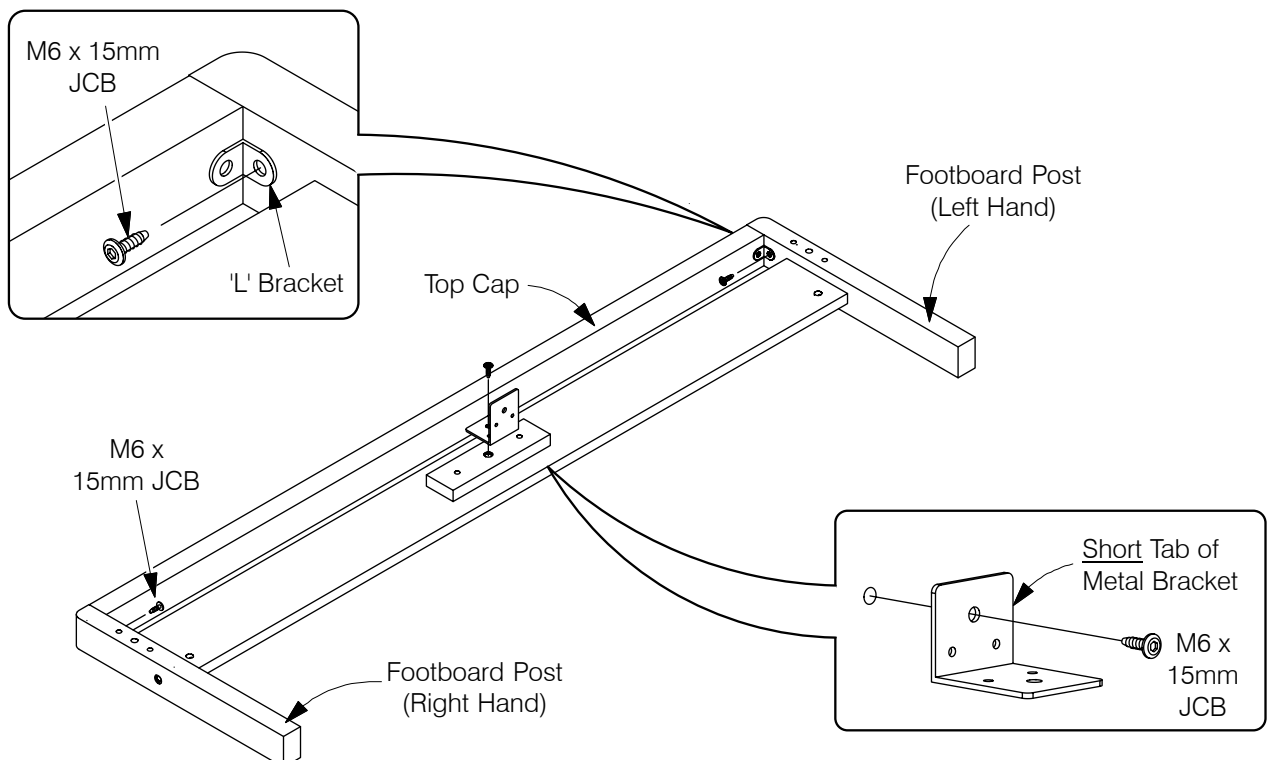

### 9 Assemble the Panels to the Headboard Post.

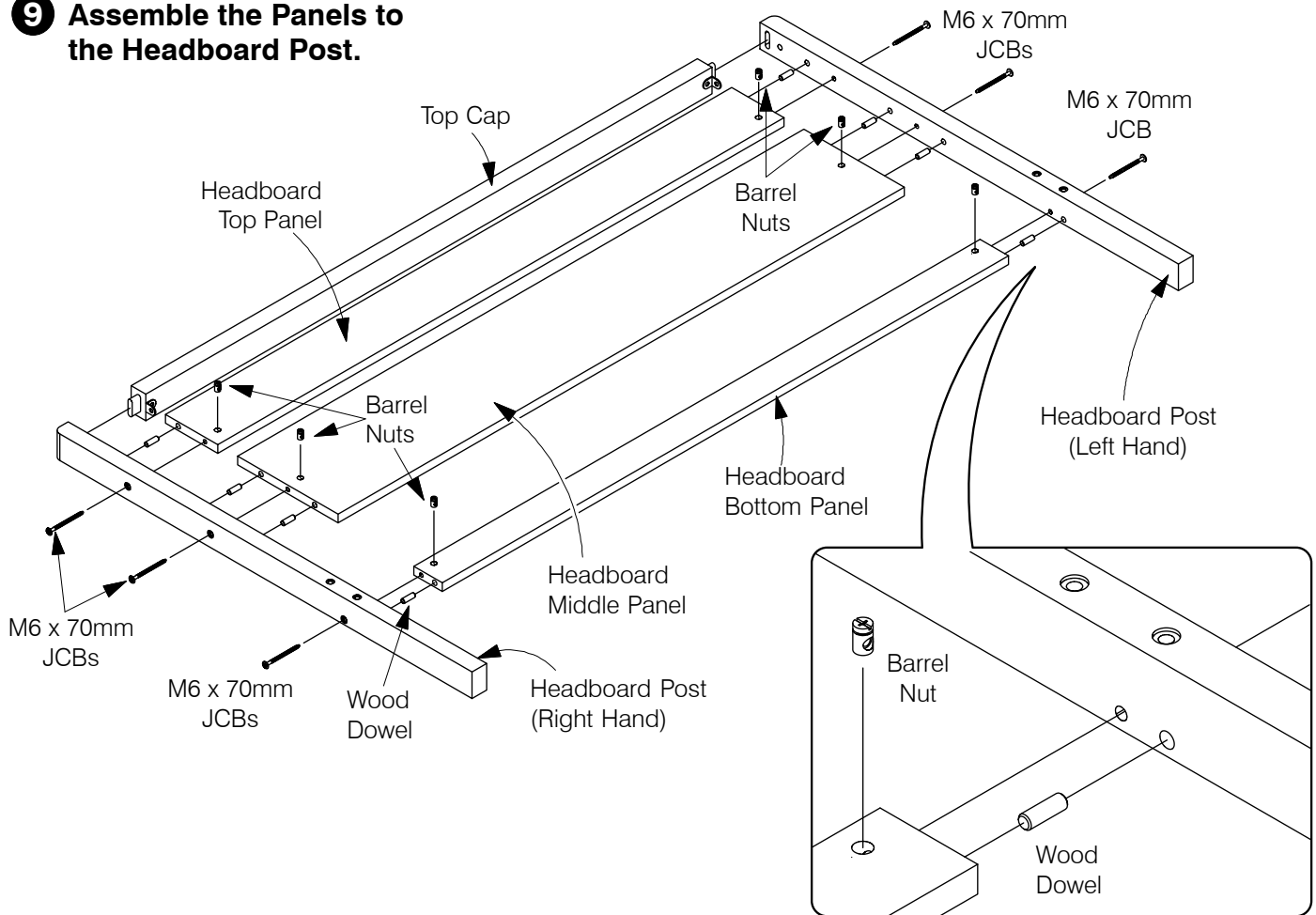

### 10 Bolt the 'L' Bracket to the Headboard Post. Fit the Center Rail Bracket to the Headboard Bottom Panel.

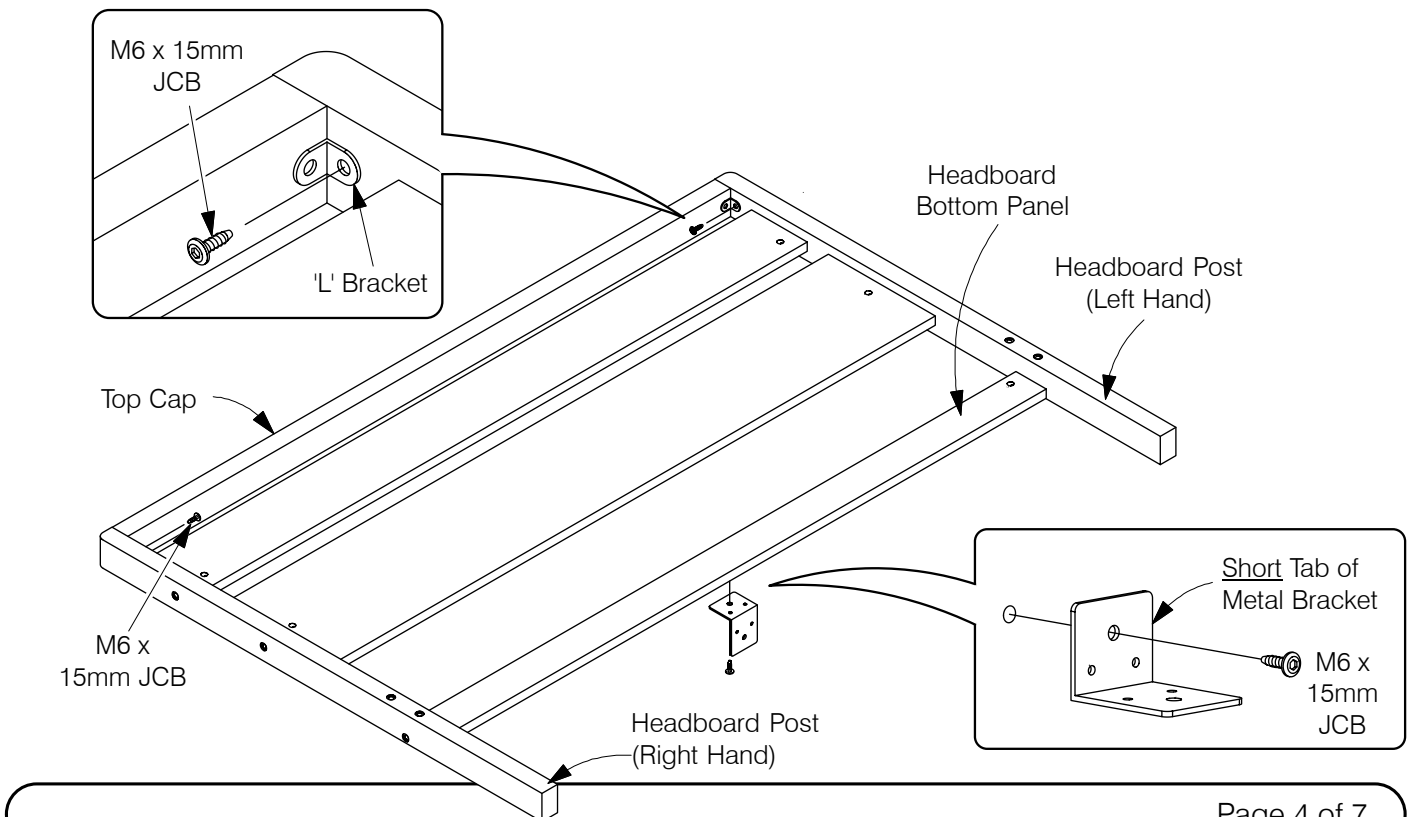

### 11 Attach the Side Rails to the Headboard and Footboard.

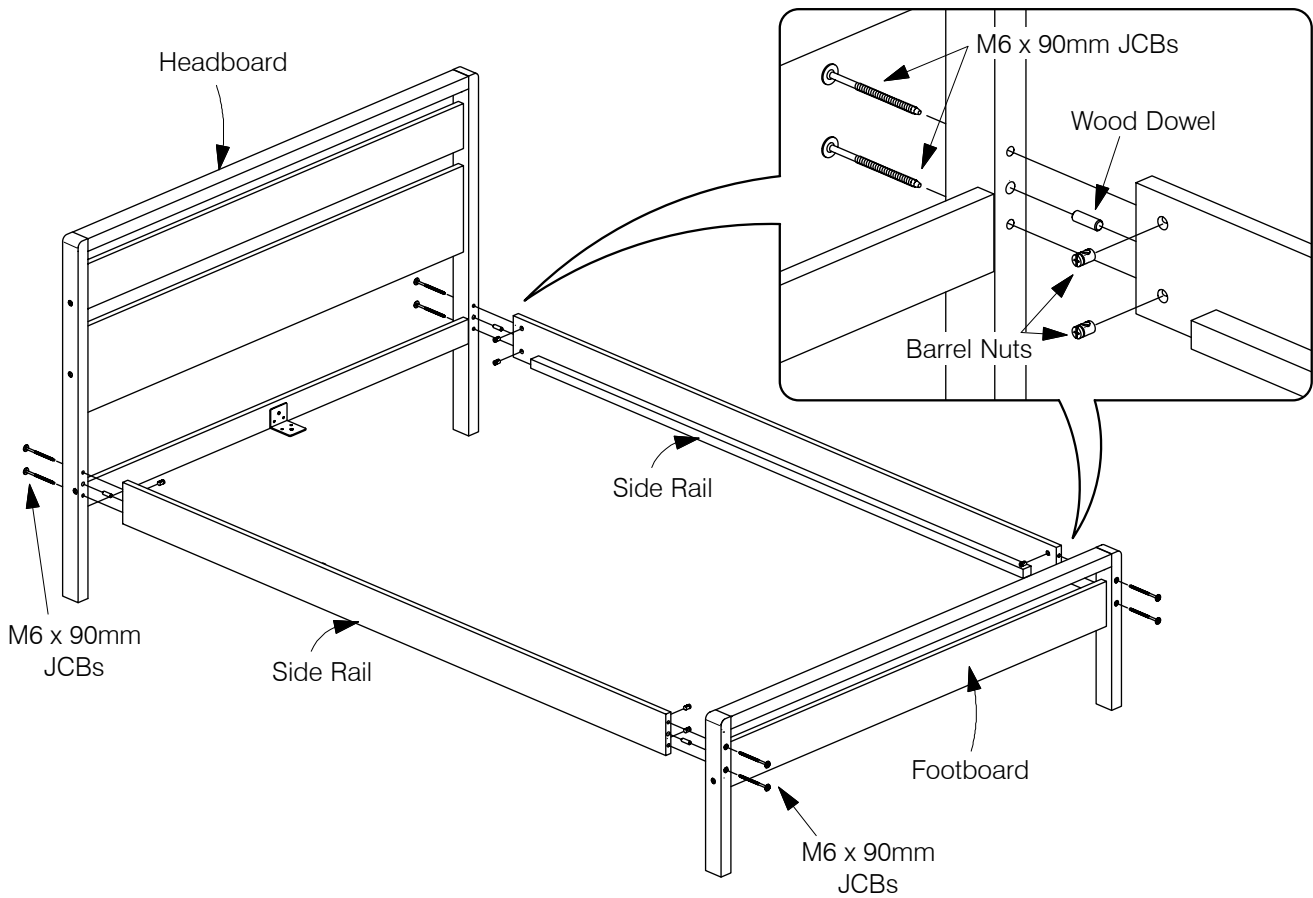

### 12 Bolt the Long Support to the Center Rail Brackets on the Head & Footboard.

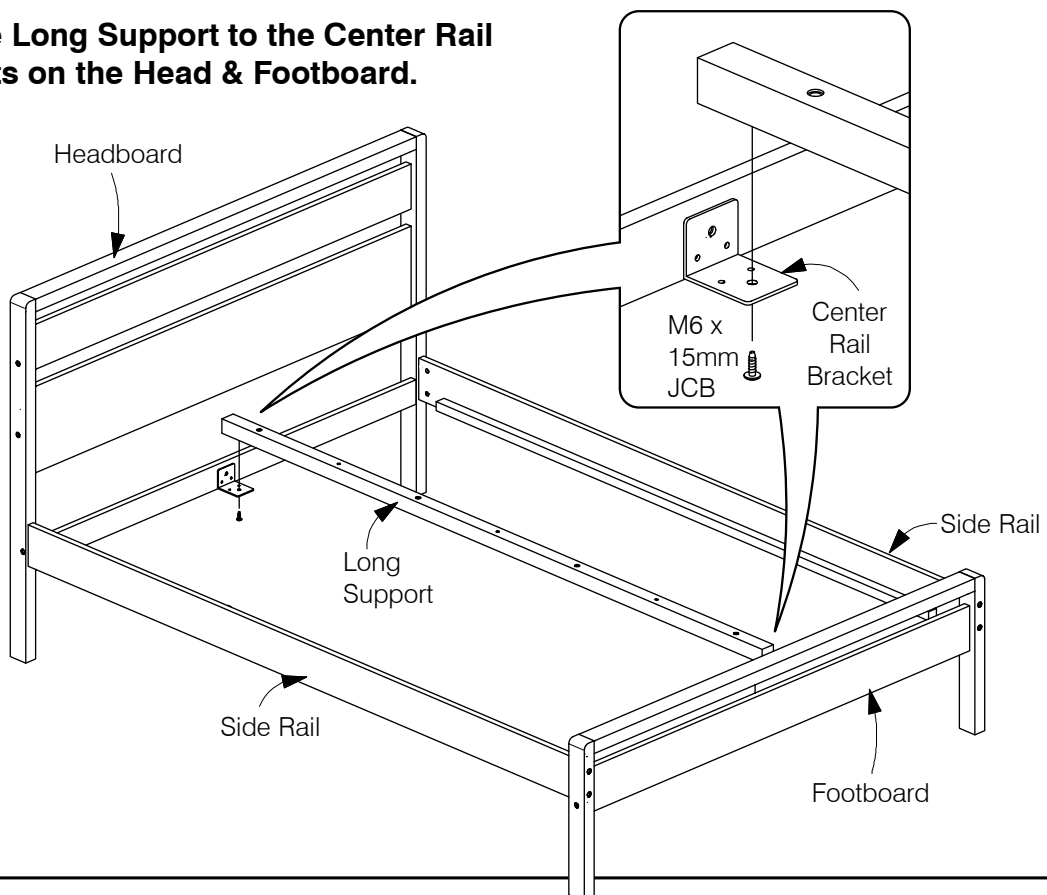

- 13** Fit the first 3 Slats and assemble the Support Leg to the Bed Slats. Bolt & screw the Bed Slats to the Side Rail & Long Support.

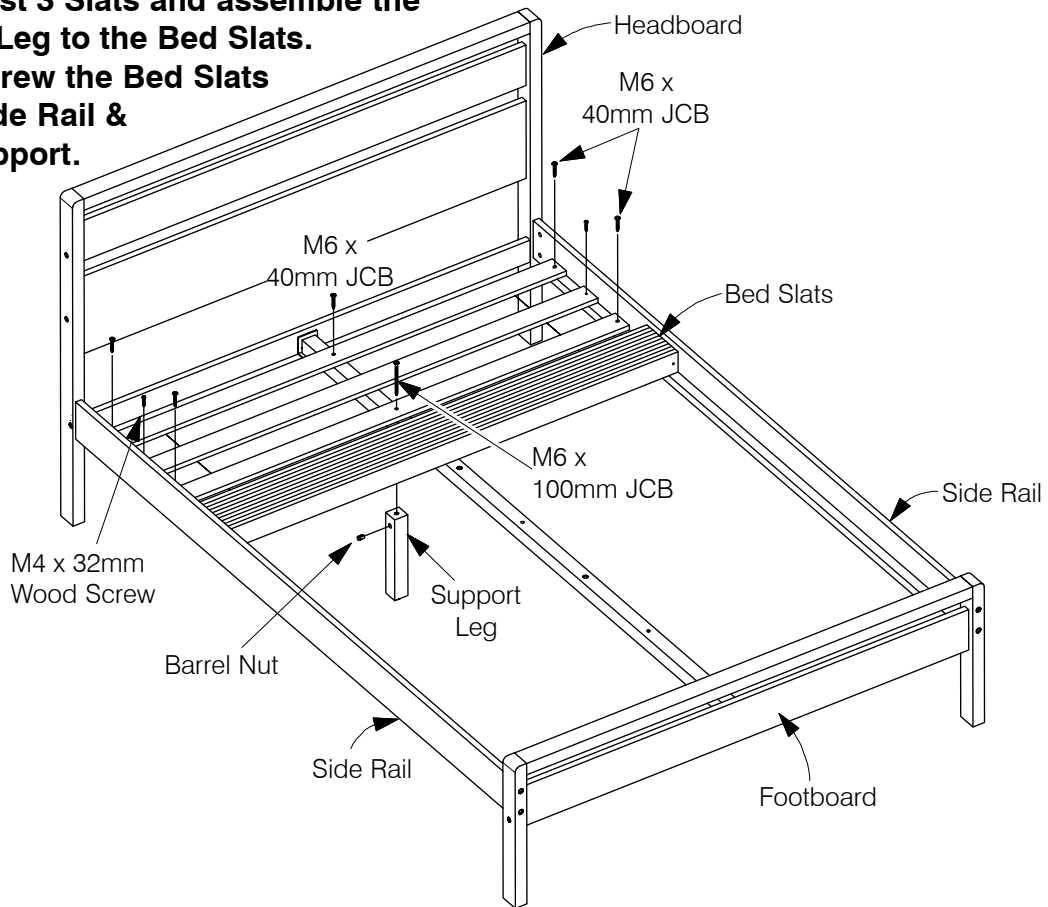

- 14** Fit the other Slats out and assemble the Support Leg to the Bed Slats. Bolt & screw the Bed Slats to the Side Rail & Long Support.

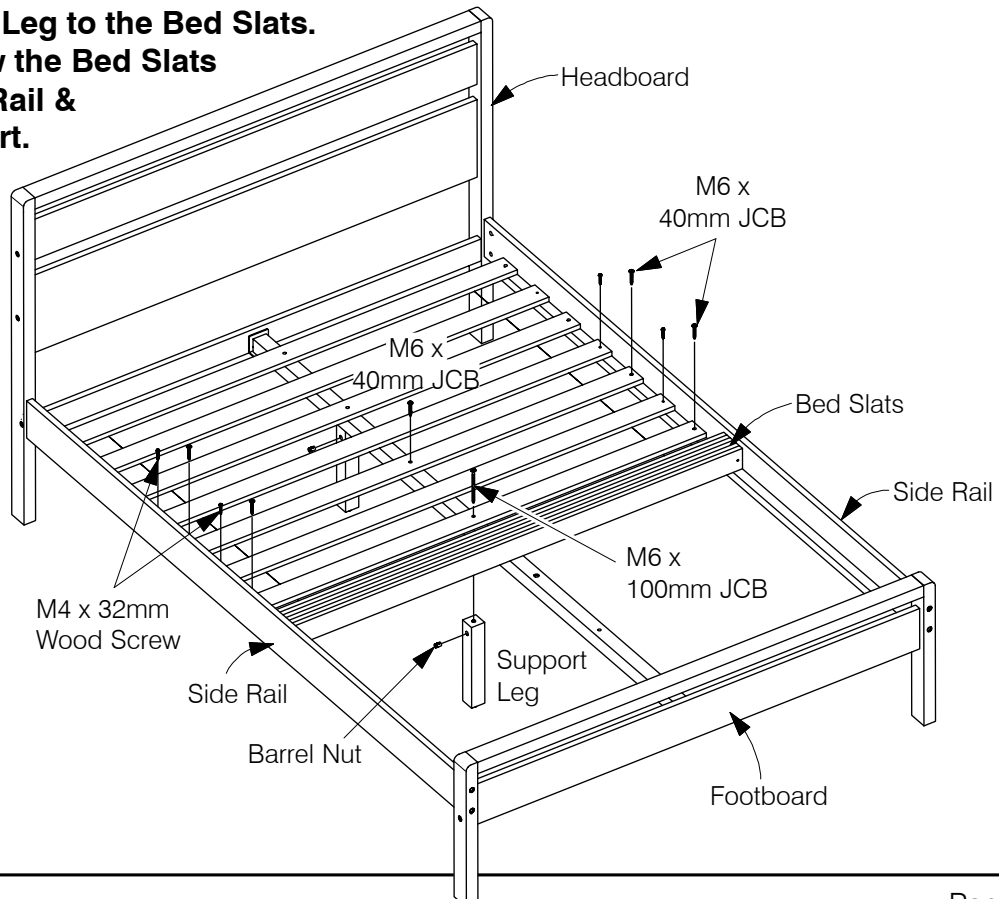

- 15** Fit the other Slats out and assemble the Support Leg to the Bed Slats. Bolt & screw the Bed Slats to the Side Rail & Long Support.

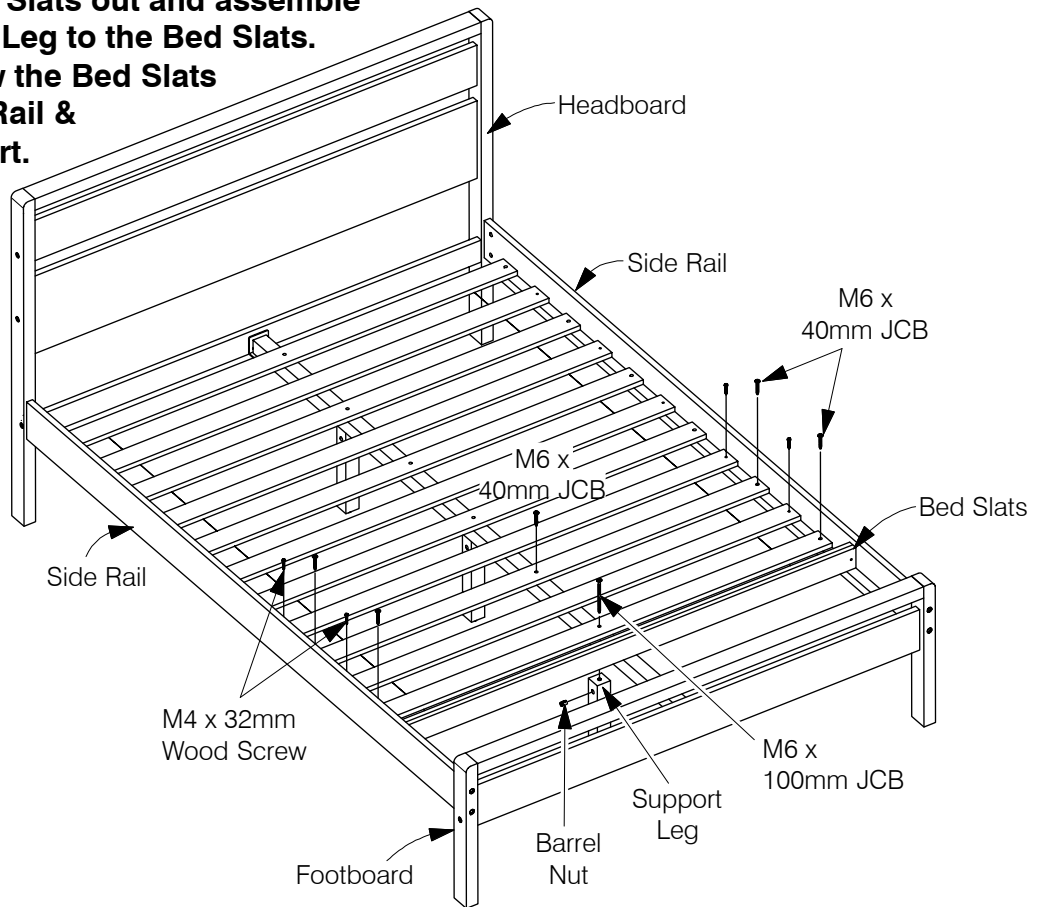

- 16** Bolt & screw the remaining Bed Slats to the Side Rail.

