

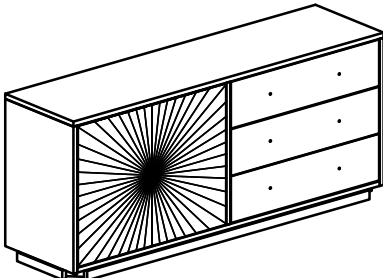

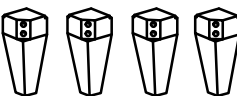





ASSEMBLY INSTRUCTION

G7576 - DINING SERVER

No	PARTS NAME	Q.ty (pcs)
A	 Chest	1
B	 Legs	4
No	LIST OF HARDWARE	Q.ty (pcs)
①	Bolts M6x50 	8
②	Spring Washers M6 	8
③	Flat Washers M6 	8
④	Allen key K4 	1
⑤	Bracket 	2
⑥	Tie 	1
⑦	Screw Ø4 x 20 	2
Screwdriver (not included) 		

STEP 1

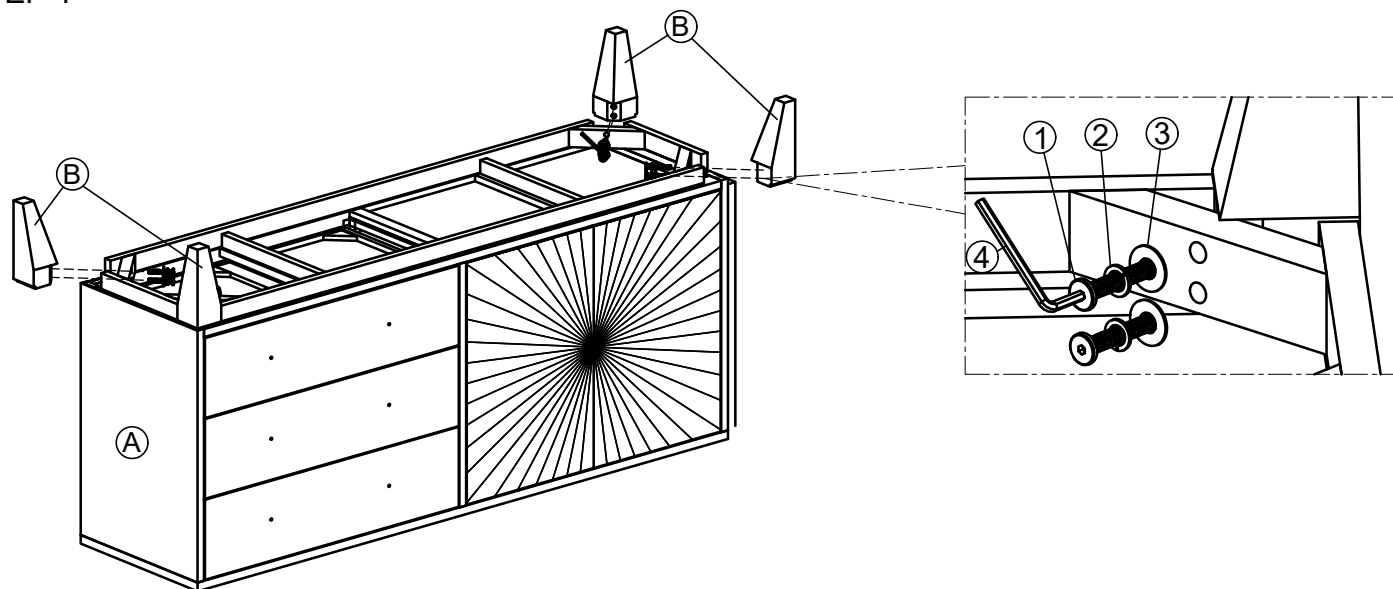

STEP 2

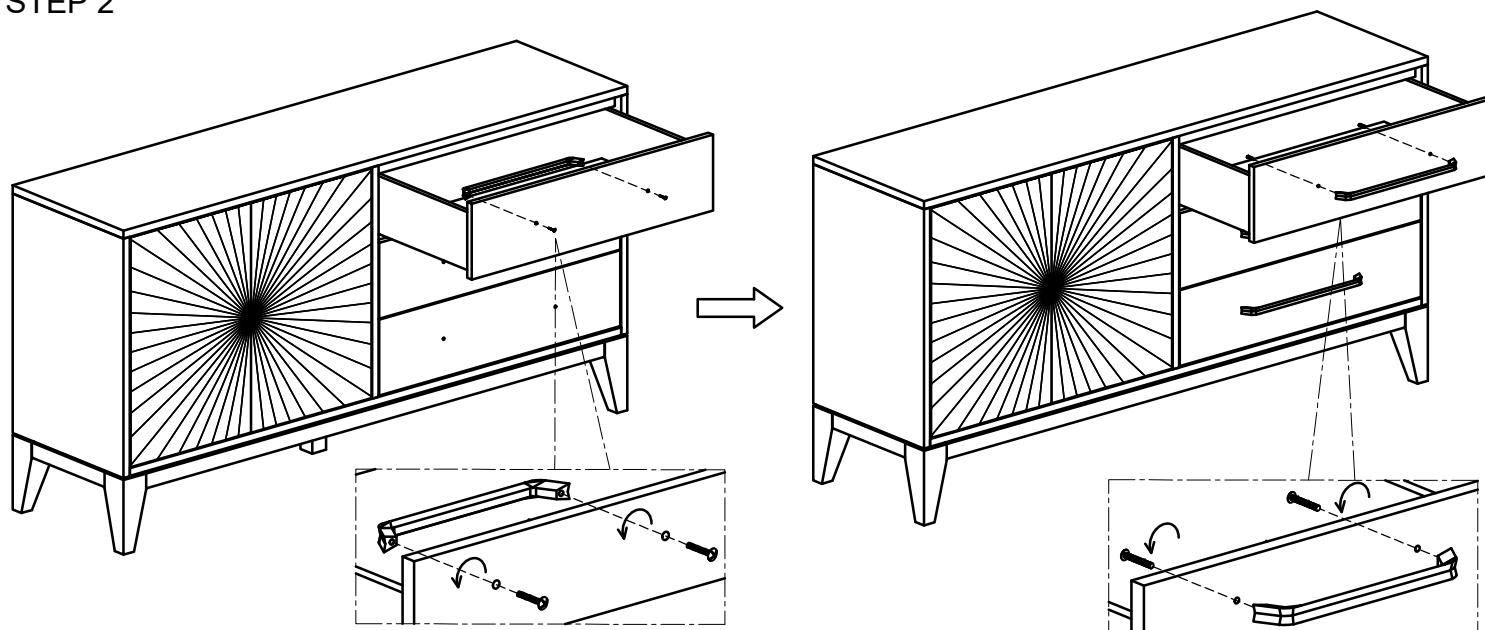

ASSEMBLY INSTRUCTION

G7576 - DINING SERVER

STEP 3

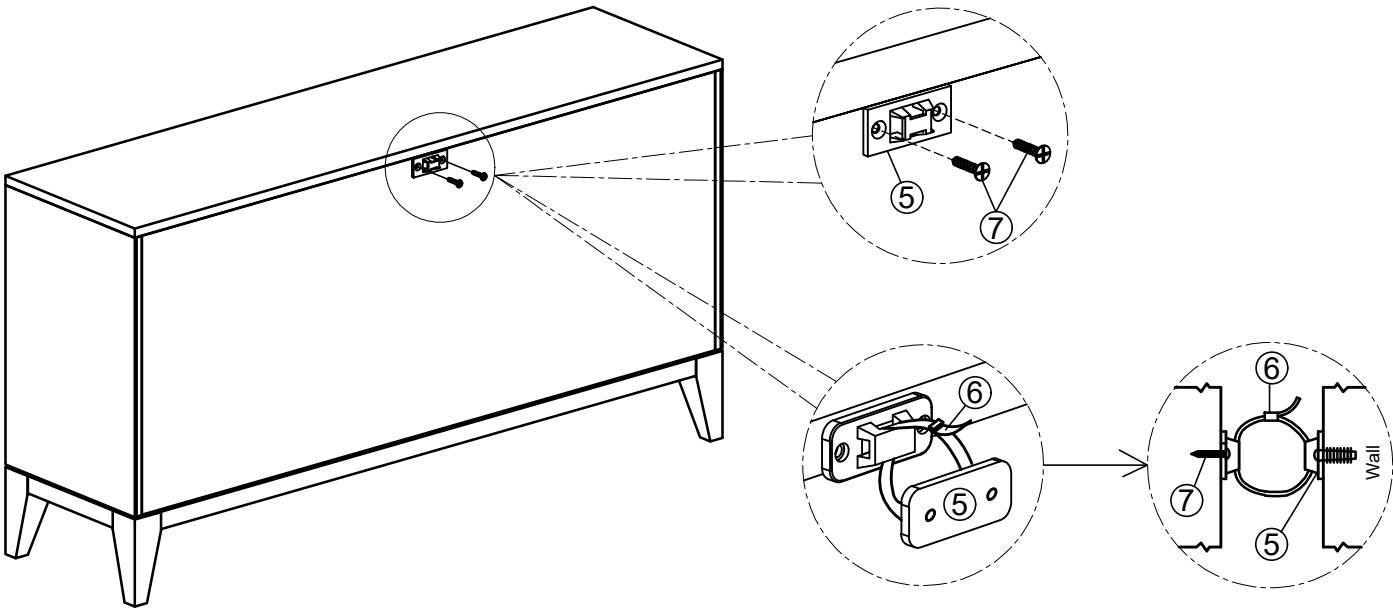

FINAL

