









ASSEMBLY INSTRUCTION

GENTS WARDROBE 3 DRAWER

No	Hardware	Qty
1	Hinge set 	6
2	Flats head Screw Ø3.5 x 15 	24
3	Screw M 5x18 	10
4	Round head Screw Ø4 x 15 	36
5	Handle with bolt 	6
6	Bracket 	4
7	Tie 	2
8	Screw Ø4 x 20 	4
9	Plastic nut 	4

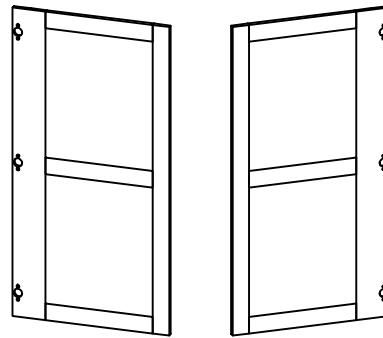

A x 2 (L-R) : Panel doors

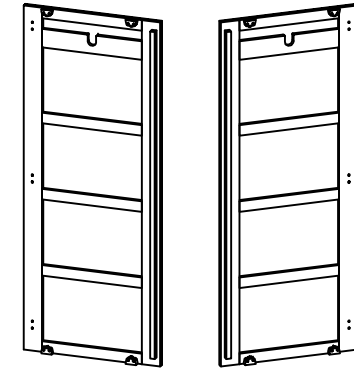

B x 2 (L-R) : Side panel

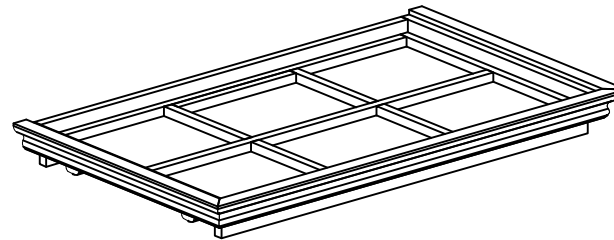

C x 1 : Top frame

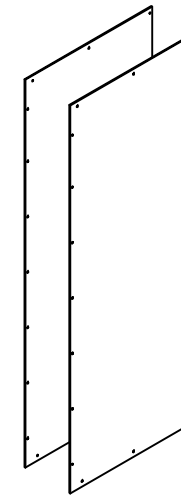

E x 2 : Back panels

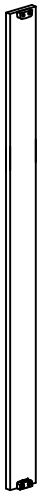

F x 1 : Back vertical rail

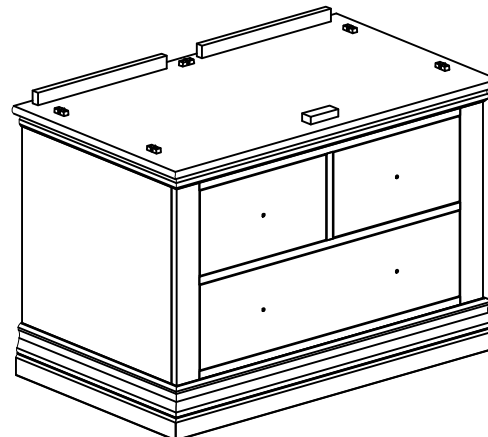
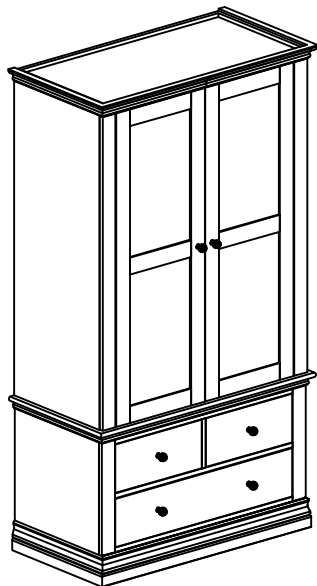

D x 1 : Base

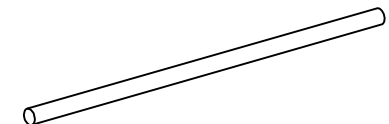

G x 1 : Hanging rail

ASSEMBLY INSTRUCTION

GENTS WARDROBE 3 DRAWER

STEP 1

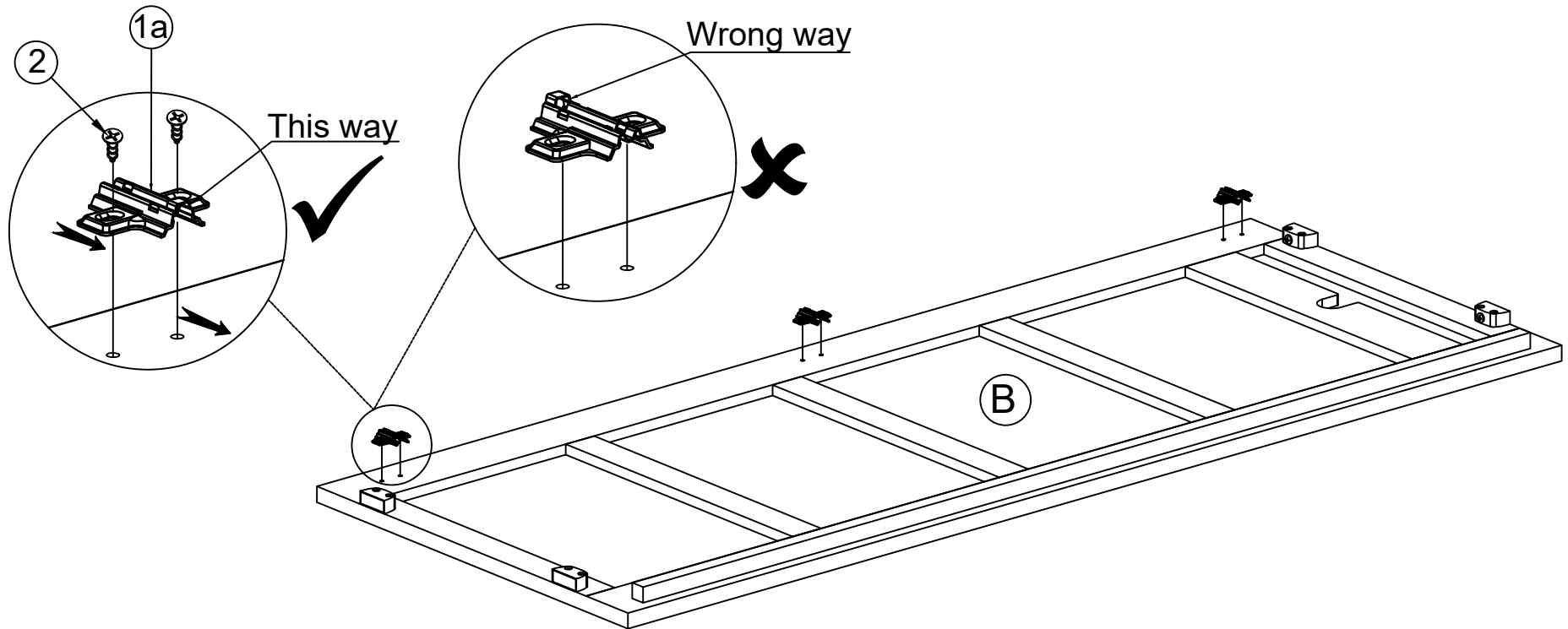
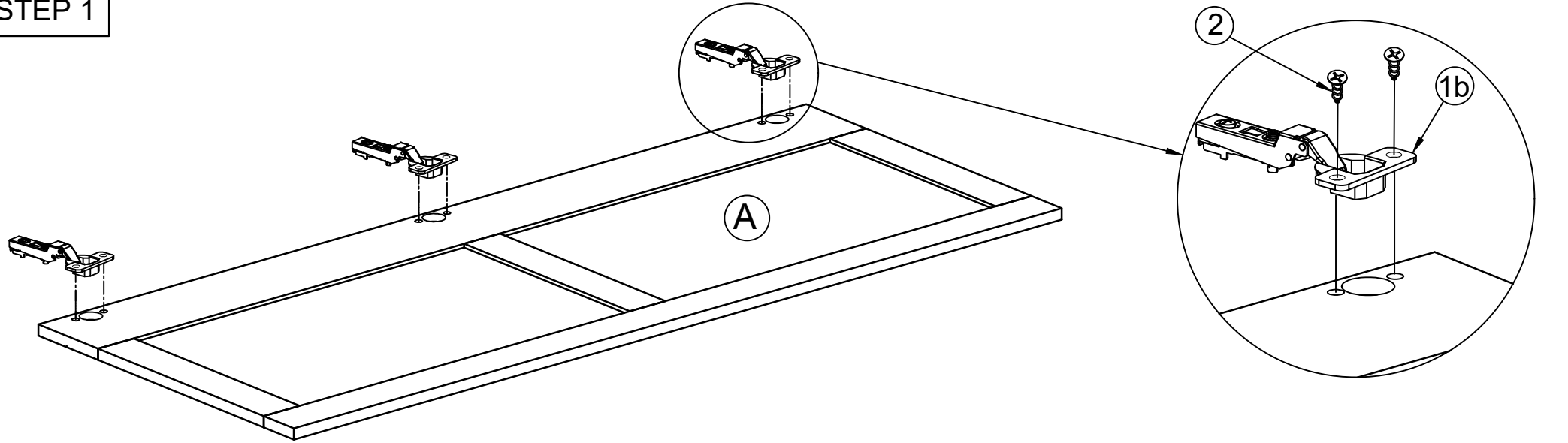

ASSEMBLY INSTRUCTION GENTS WARDROBE 3 DRAWER

STEP 2

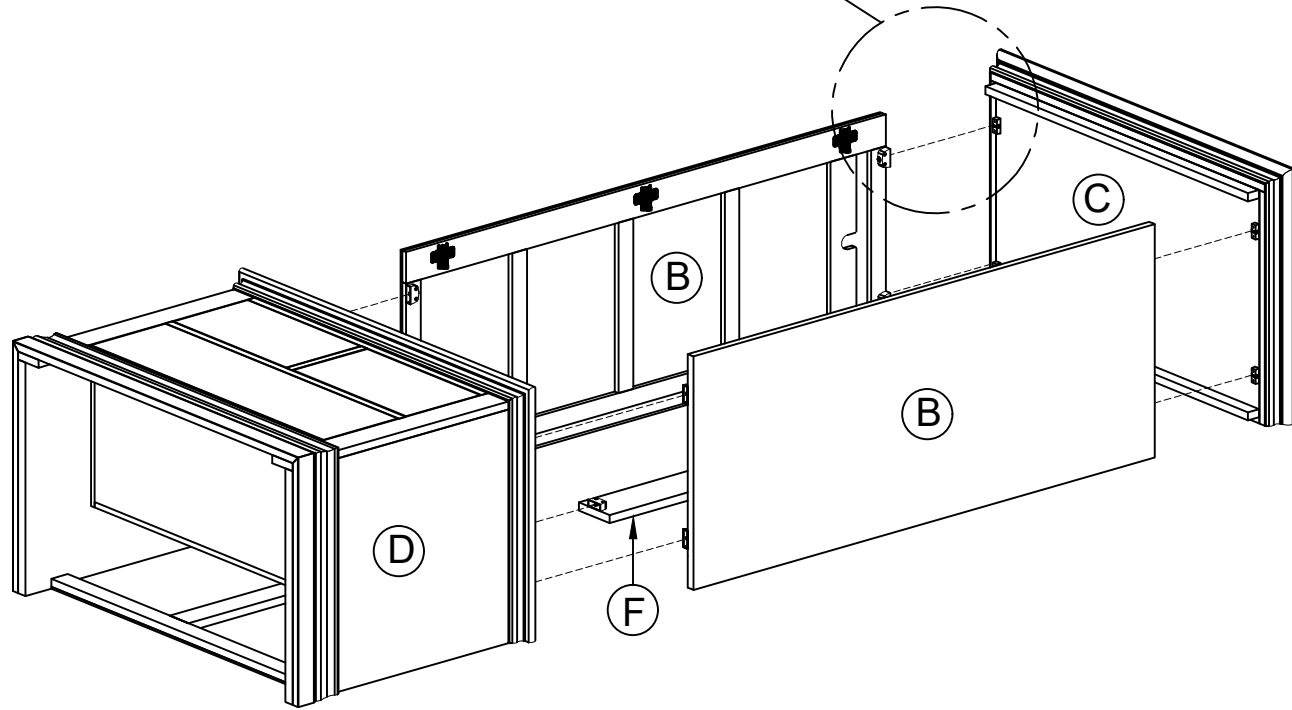
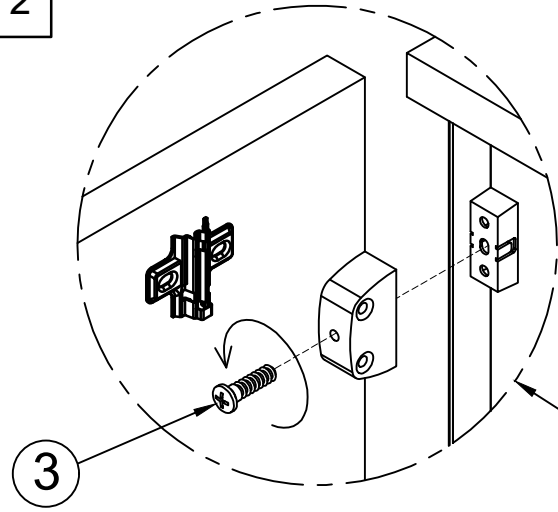

STEP 3

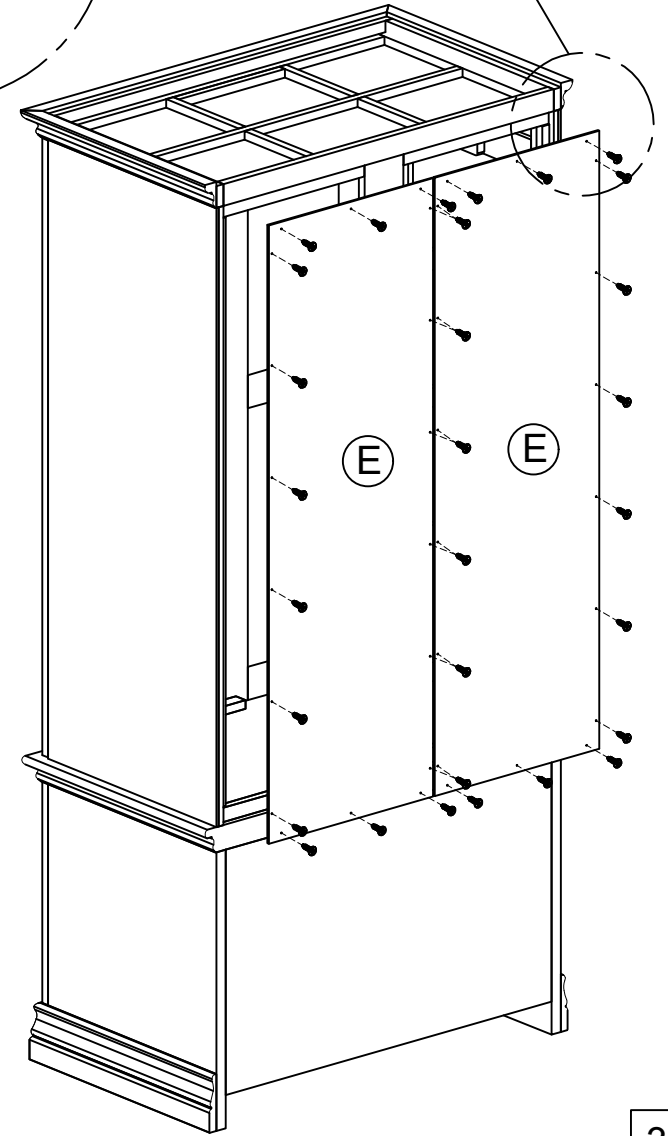
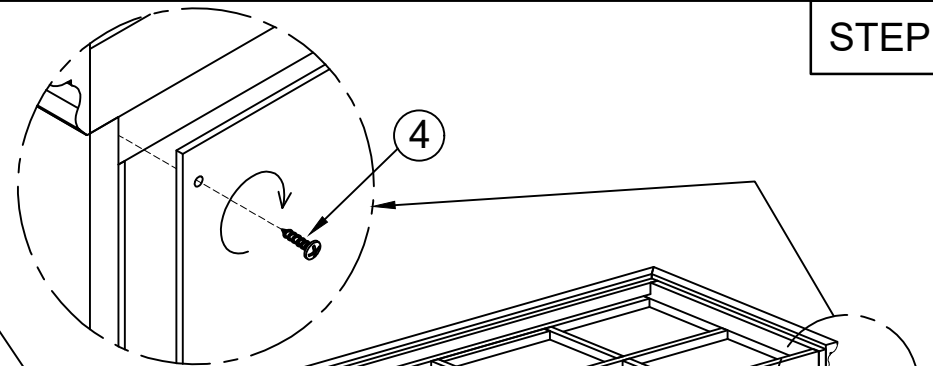

ASSEMBLY INSTRUCTION

GENTS WARDROBE 3 DRAWER

STEP 4

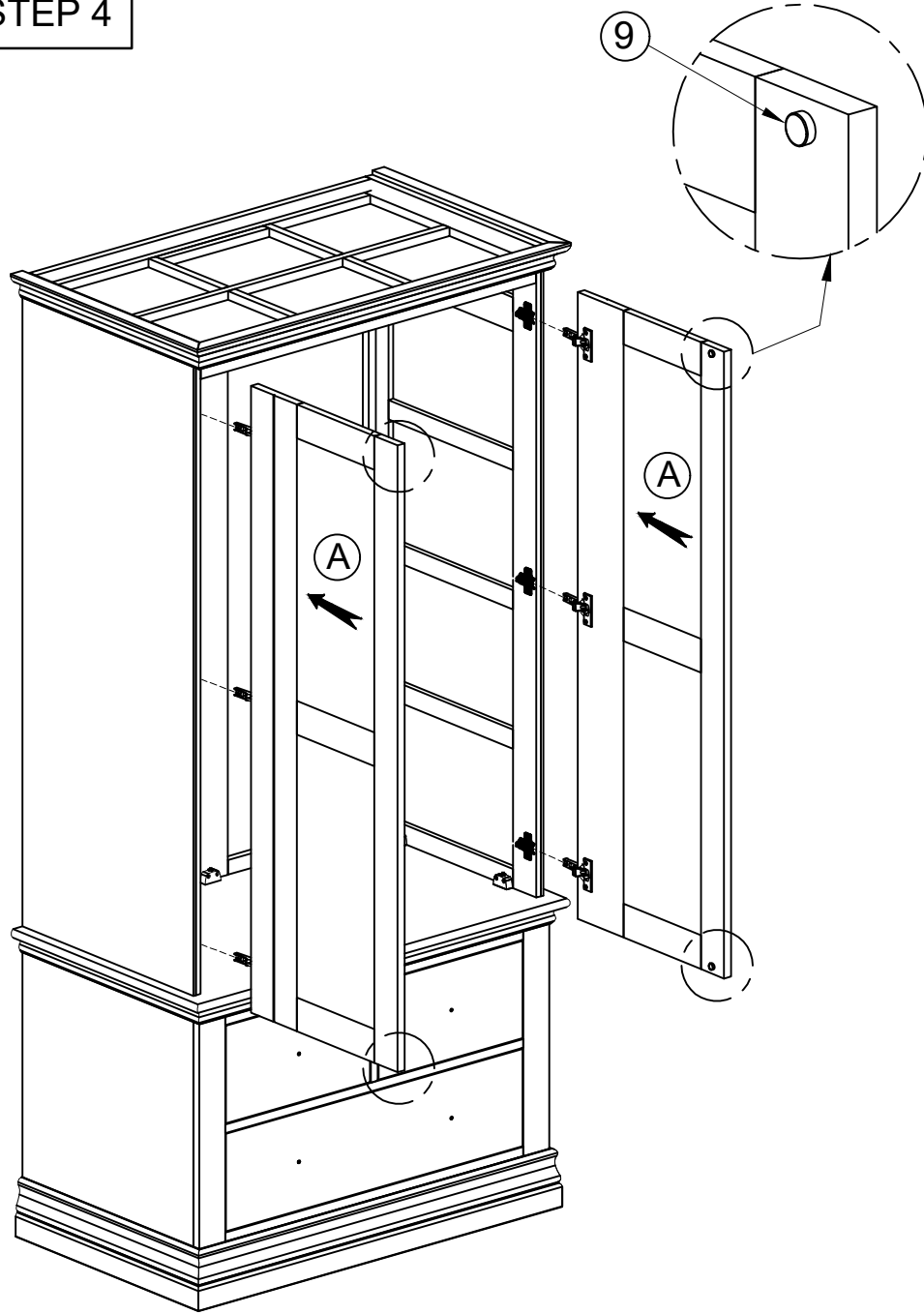

STEP 5

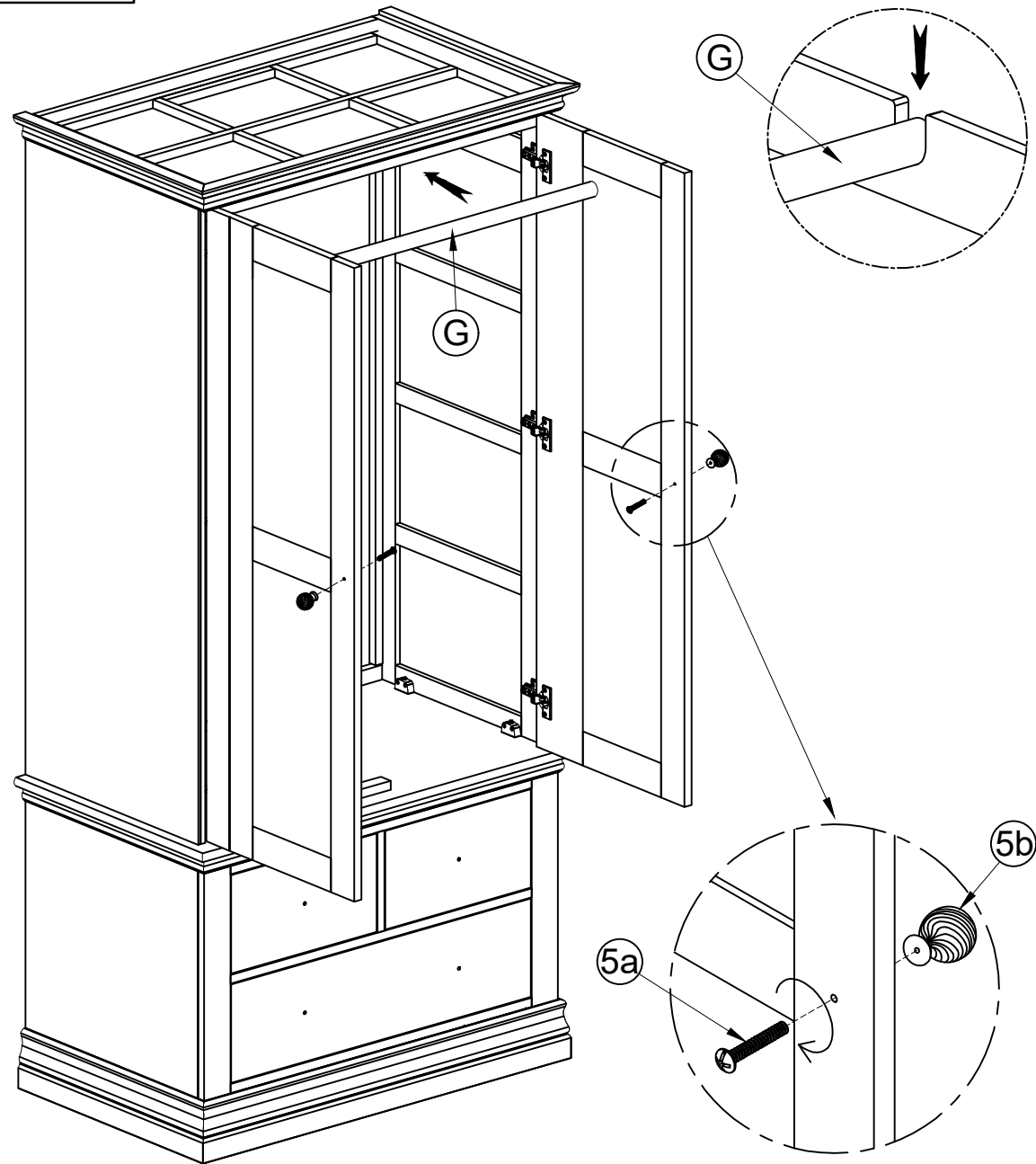

ASSEMBLY INSTRUCTION

GENTS WARDROBE 3 DRAWER

STEP 6

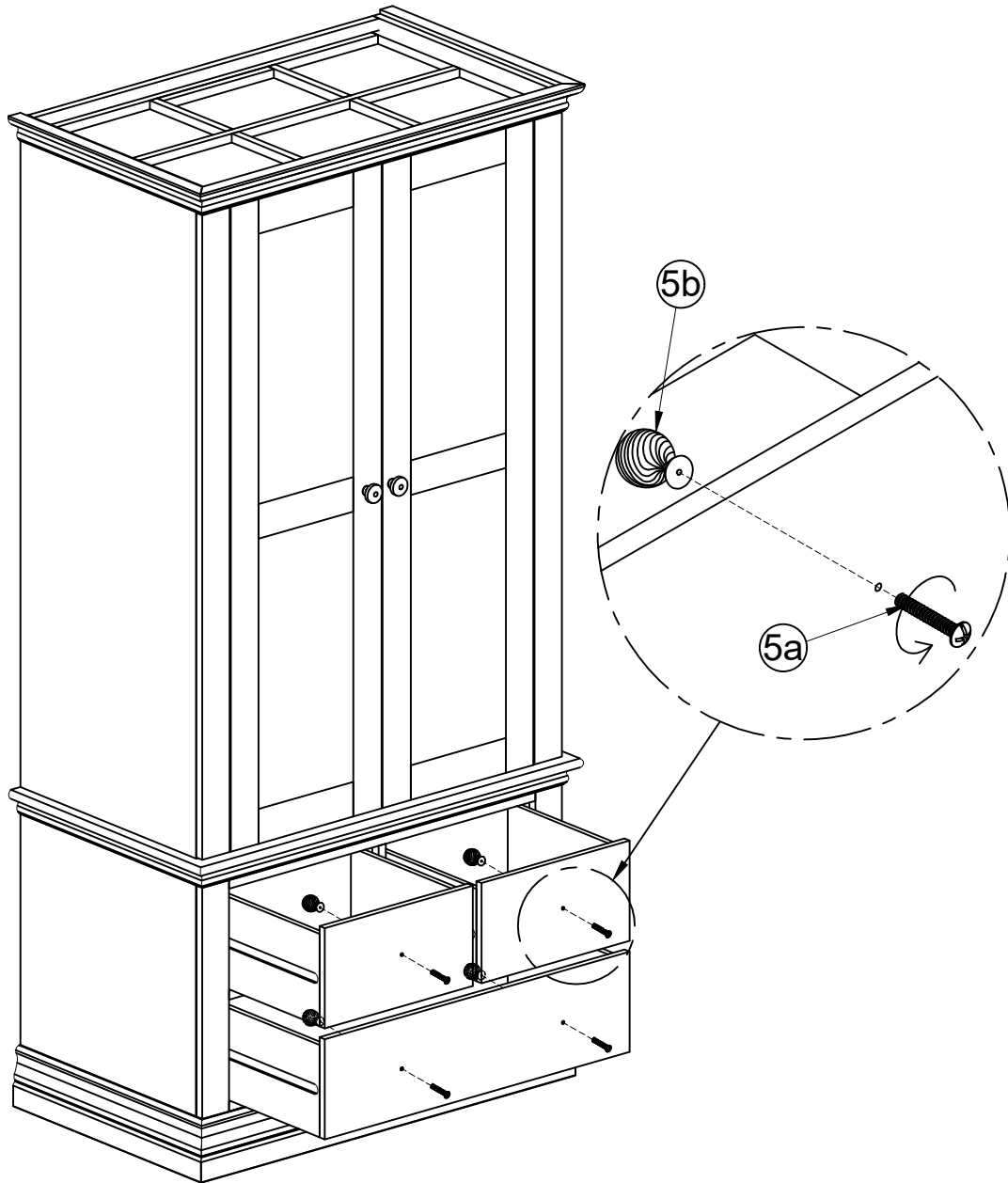

STEP 7

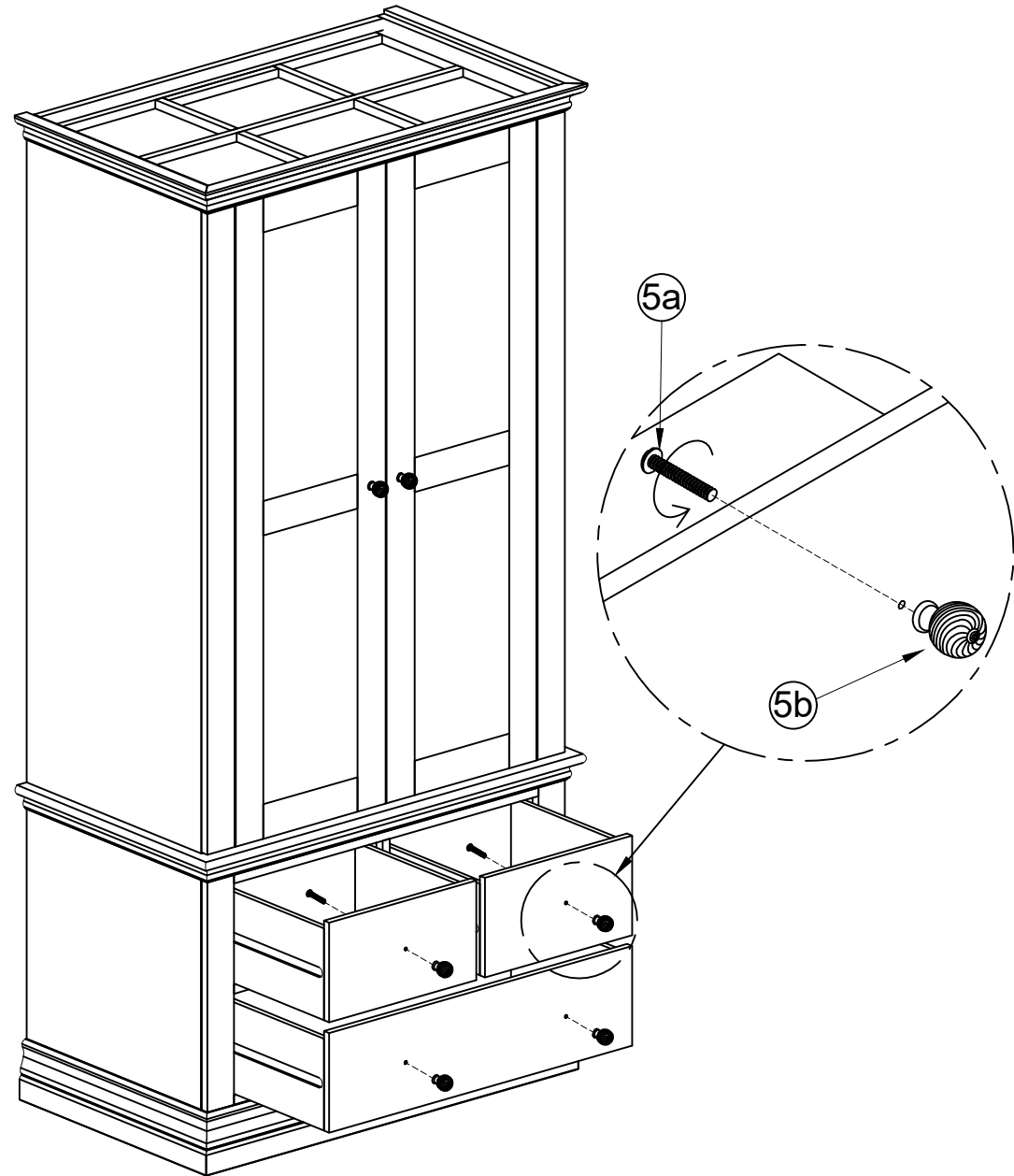

ASSEMBLY INSTRUCTION

GENTS WARDROBE 3 DRAWER

STEP 8

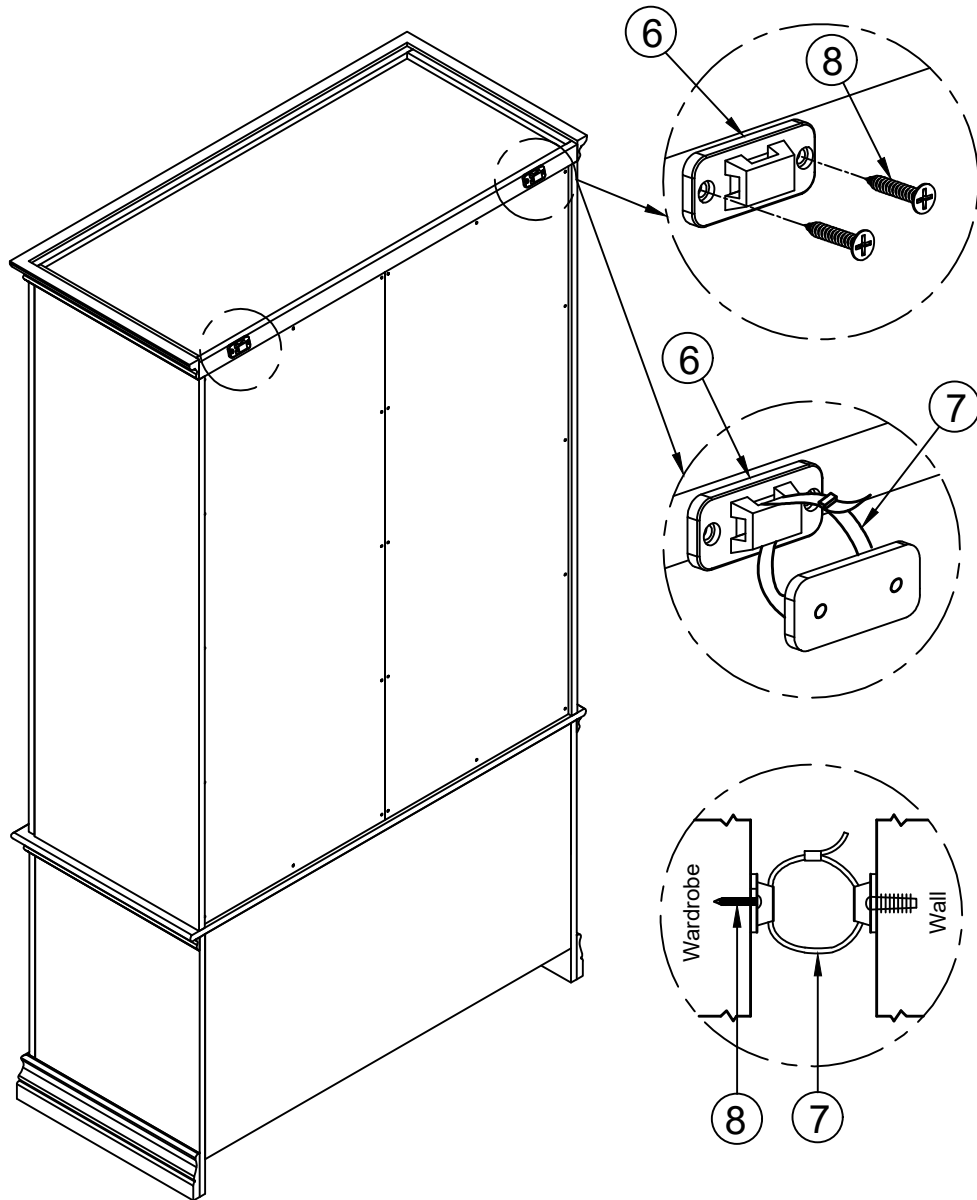

FINAL

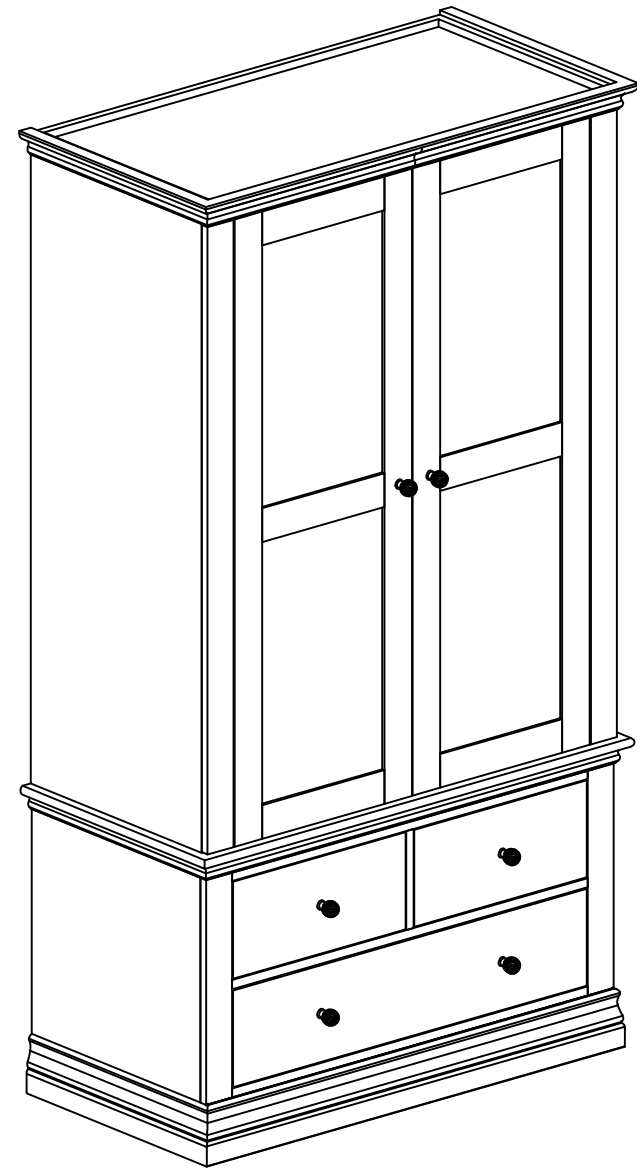

HINGE ADJUSTMENT INSTRUCTIONS

LATERAL ADJUSTMENT

by screw adjustment.

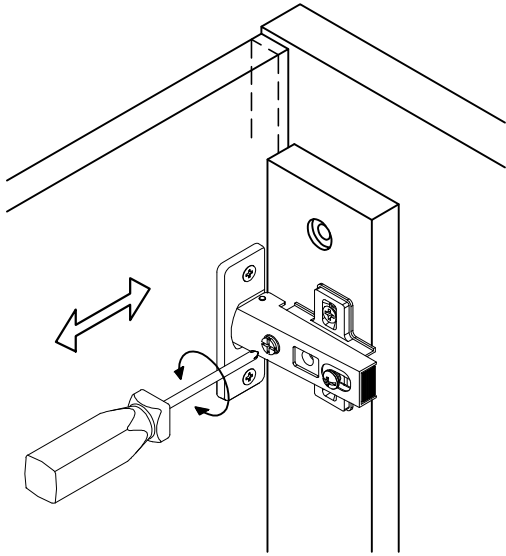

FRONT-TO-BACK

by slackening and retightening the hinge-arm mounting screw.

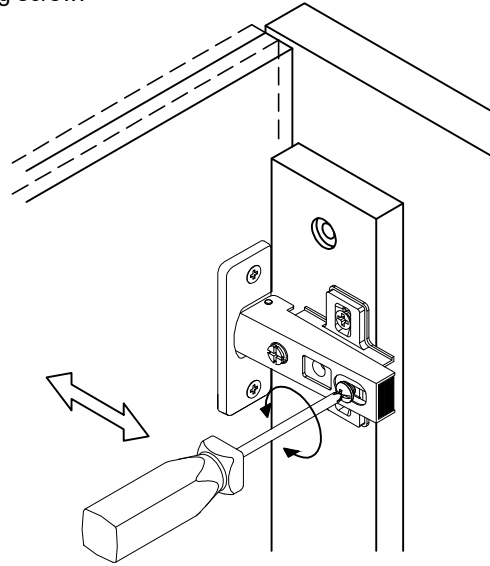

VERTICAL ADJUSTMENT

via slots on mounting plate by slackening and retightening the screws on mounting plate

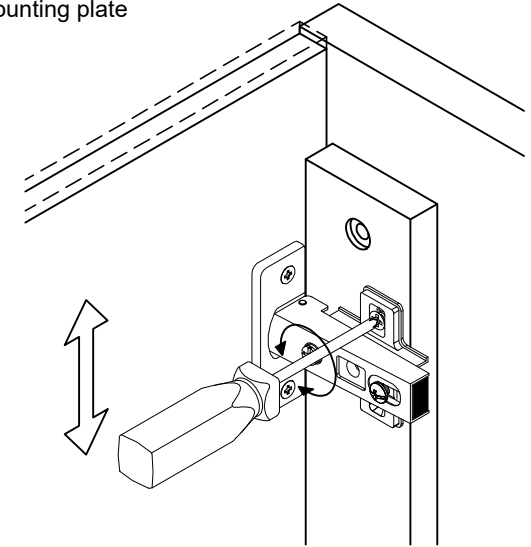

ASSEMBLY

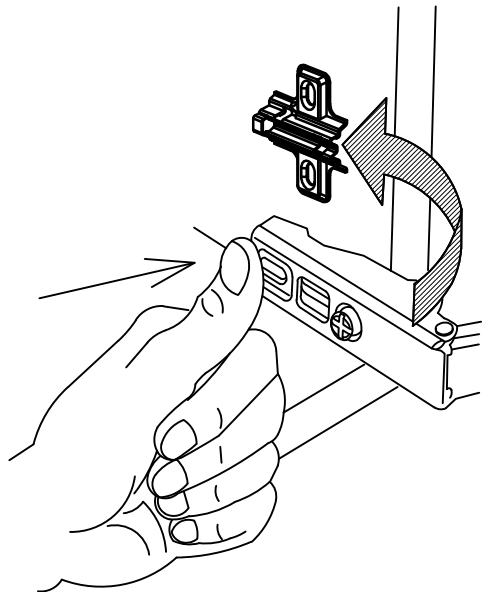

DISASSEMBLY

