

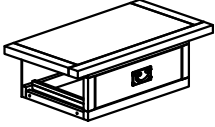





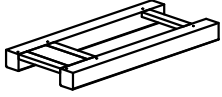

ASSEMBLY INSTRUCTION TELEPHONE TABLE

No	Name of Component	Q.ty
(A)	 Table top frame	1
(B)	 Shelf	1
(C)	 Leg	2

No	Name of Hardware	Q.ty
(1)	 Bolt M6 x 35	8
(2)	 Bolt M6 x 60	4
(3)	 Washer Ø7/Ø15 x 1	12
(4)	 Allen key K4	1
(5)	 Bracket	2
(6)	 Tie	1
(7)	 Screw Ø4 x 20	2

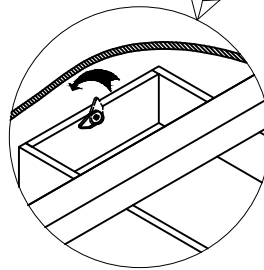
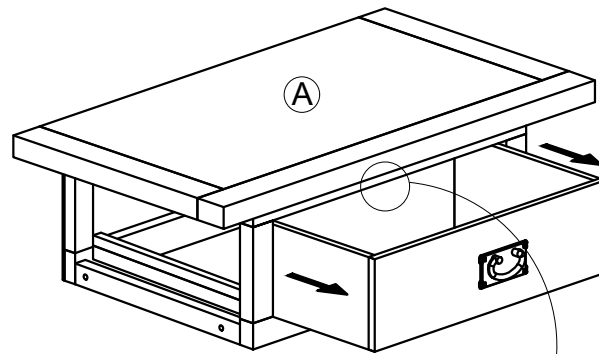

Step 1: Take out Drawers

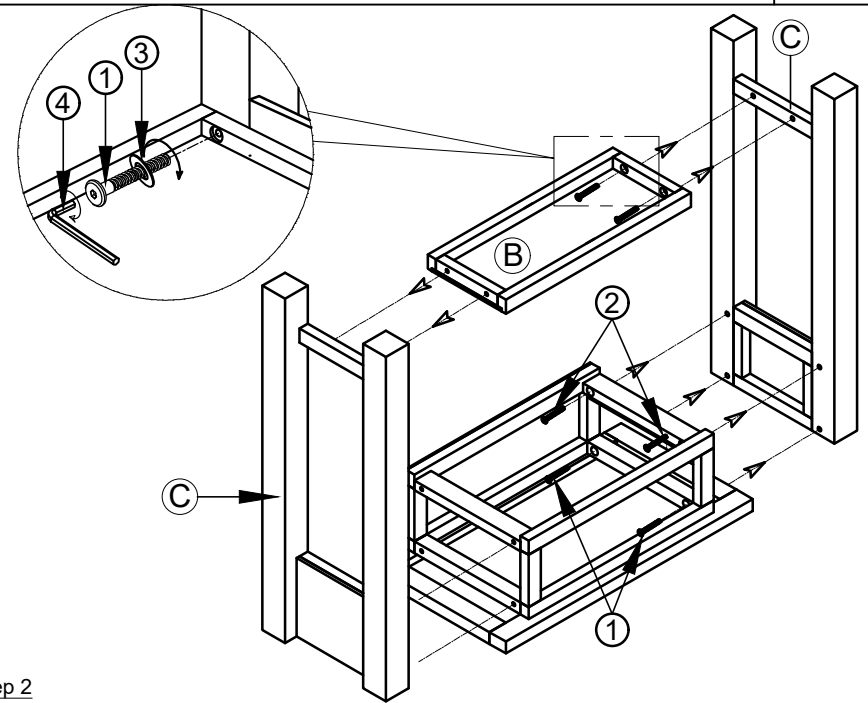

Step 2

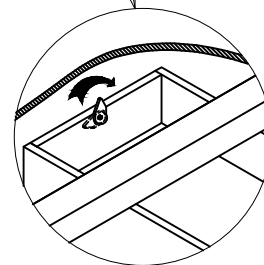
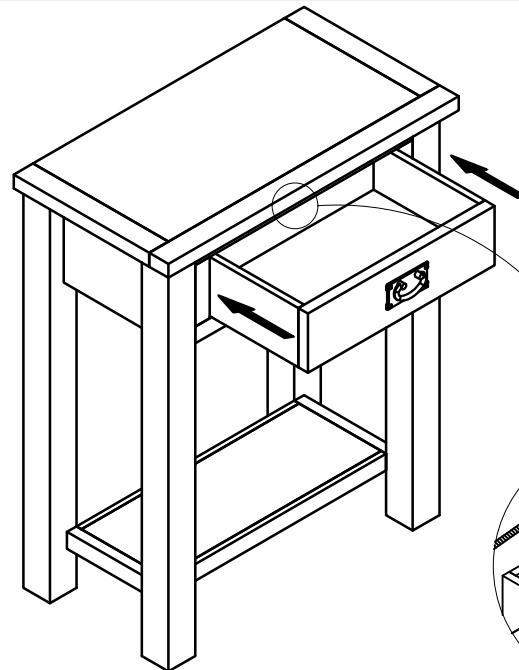

Step 3

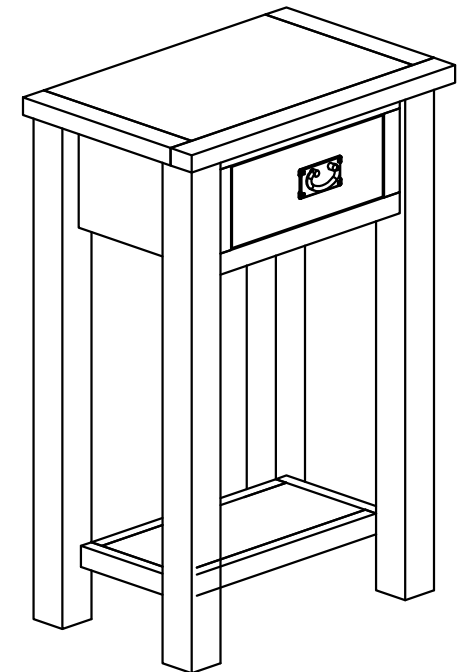

Step 4

ASSEMBLY INSTRUCTION TELEPHONE TABLE

Step 5

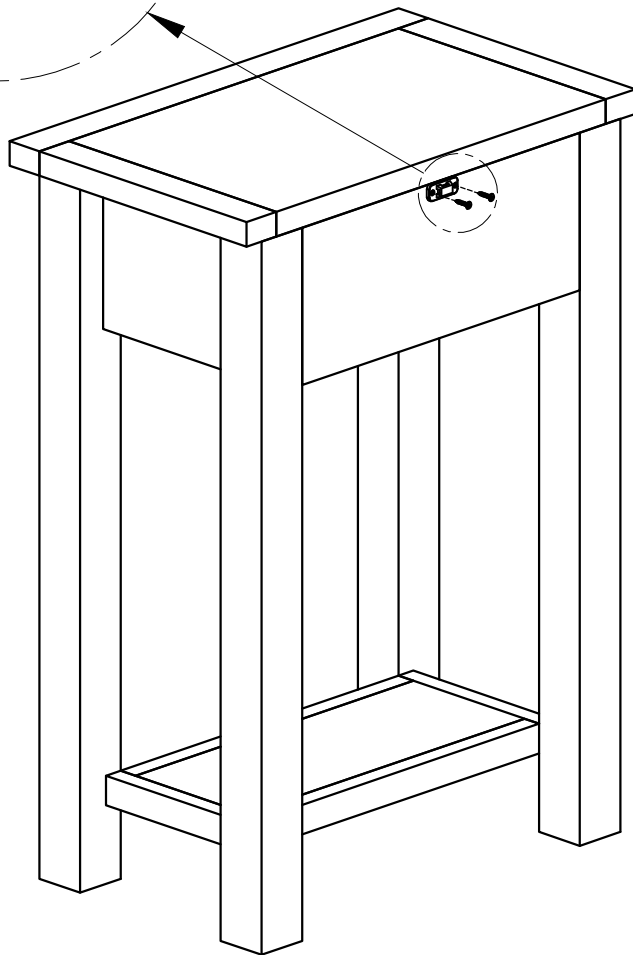
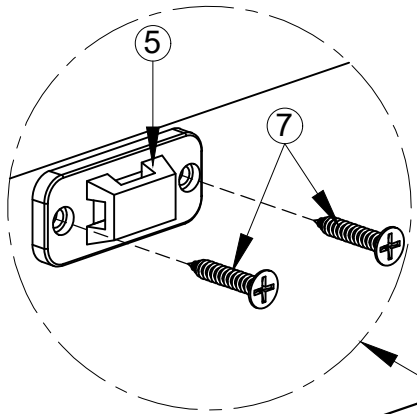

FINAL

