

Product size:
L170*W110*H150 cm

Note: The diagrams are for
assembly reference only.
It may be some different to
the actual products.

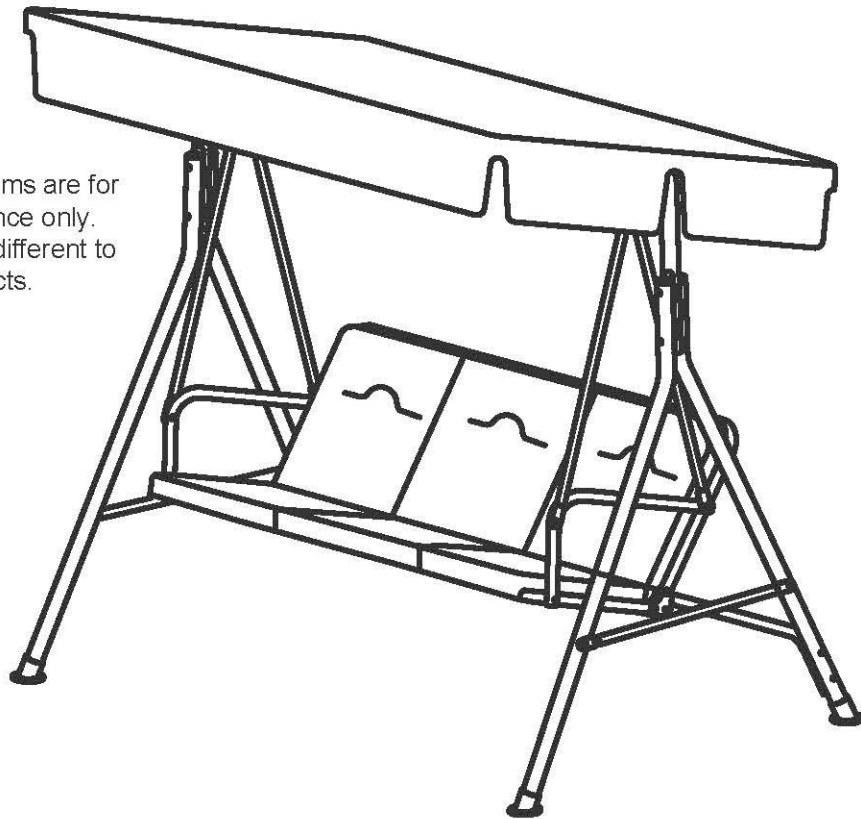

The frame of this product is manufactured from mild steel coated with a weather resistant paint. Steel has a natural tendency to rust over time and, whilst we expect you to be able to enjoy your furniture for many years to come, we recommend that you check the product from time to time for signs of paint damage and/or rust. If the paint should become damaged, or if rust begins to form, you should clean the affected area and apply a suitable "thinners based" touch-up paint.

Such paints are readily available from all good hardware and DIY stores.

**Furniture should be covered/stored whilst not in use to prolong its longevity.
(It should also be covered in adverse weather.)**

The intended use of this product is for domestic use only.

Important, please retain for future reference.

Read carefully.

Cairo Hammock Swing

Assembly Instructions

Before you start



Warnings

IMPORTANT, RETAIN FOR FUTURE REFERENCE READ CAREFULLY

See enclosed instructions for assembly, safety and care information.

Failure to follow the warnings could result in serious injury.

Handle heavy parts with care.

Ensure that this product is fully assembled as illustrated before use.

This product should only be used on firm, level ground.

Keep small parts out of reach of children.

This product is intended for **domestic use** only.

Ensure the product is always placed on level ground.

Furniture can be dangerous if incorrectly used. No liability will be accepted for damage or injury caused by incorrect use of this product.



Dos

When you are ready to start, make sure that you have the right tools, plenty of space and a clean, dry area for assembly.

Unwrap all packaging materials and place the components on a suitable surface to prevent scratching your product.

Check all contents are present prior to assembly as per the parts list provided. In the event of problems or missing parts, please contact the seller.

Check all screws and bolts are tightened and inspect regularly.

Cover furniture when not in use to add additional protection to your product.

Store all cushions indoors after use as they are not waterproof.

Frames are manufactured using powder coated aluminum tubing. Any scratches on the paintwork should be touched up immediately with metal paint to prevent corrosion.

During severe weather conditions, including high winds, rain, hail, thunderstorms, extreme heat and cold temperatures, the product should be stored inside in a cool, dry place.

To best preserve this product, please use a protective cover when your furniture is not in use. We would also recommend using a gazebo or parasol over your furniture during the summer period and prolonged sunny spells. This will help prevent harmful UV rays from damaging and discolouring the material.

Ensure that the product is clean and dry before storage.

Clean your product with a sponge and warm soapy water then wipe with a clean, dry cloth.

Cushions should be cleaned following the care instruction on the label.

This product is suggested to be assembled at the place of use.

Where instructions as to the; storage, commissioning, installation, use and maintenance of the goods or (if there is none) good trade practice are not followed and a defect arises this will void the 12 month manufacturer's guarantee on the product.



Don'ts

Do not stand or climb onto the product.

Do not use power tools to construct this product.

Do not sit or lean onto the rims of this product.

Do not use this product if parts are missing, damaged or worn.

Never use scourers, abrasives or chemical cleaner.

Do not use this product as a ladder as this could lead to the product becoming unbalanced and overturning.

Do not place very hot or very cold items on this product surface.

Never drag furniture when moving it, always lift it.

Don't tilt/sway the swing backwards and forwards violently!

Number of people required for assembly

Two people



Time to assemble







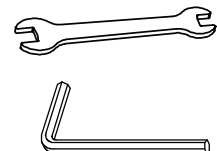

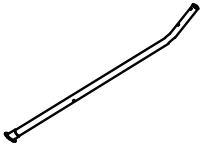
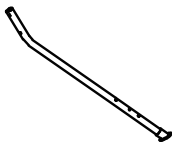

50 minutes

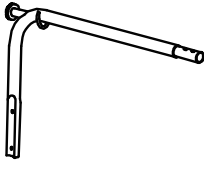
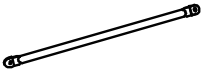

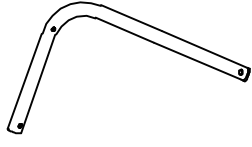

Tools required







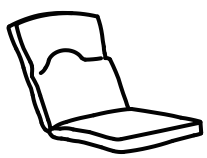
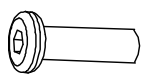

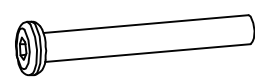
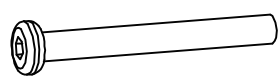
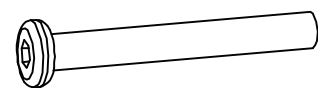
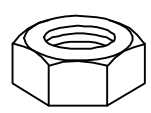
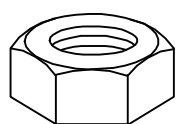

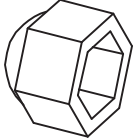
Components, fixtures & fittings (not actual size)

Part No.	Diagram & Description	Qty.	Part No.	Diagram & Description	Qty.
A	 Front Leg	2	B	 Rear Leg	2
C	 Top Female Bar	1	D	 Top Male Bar	1
E	 Front and Back Leg Connecting Bar	2	E1	 Hanging Bar	4
F	 Rear Bottom Male Bar	1	G	 Rear Bottom Female Bar	1
H	 Spring Hook	2	I	 Armrest	2
J	 Seating Frame	1	K	 Canopy End Bar	2

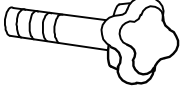

Part No.	Diagram & Description	Qty.	Part No.	Diagram & Description	Qty.
L	 Canopy Front/Back Bar	2	M	 Canopy	1
N	 Seat & Backrest Cushion	3			
O	 M6*30mm Bolt	1	P	 M6*36mm Bolt	2
Q	 M6*48mm Bolt	6	R	 M6*60mm Bolt	4
S	 M6*68mm Bolt	4	T	 M8*90mm Bolt	4
U	 M6 Nut	17	V	 M8 Nut	4

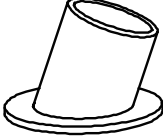
Part No.	Diagram & Description	Qty.	Part No.	Diagram & Description	Qty.
W	 M8 Nut Cap	4	X	 M6 Nut Cap	21
Y	 M6mm Washer	17	Z	 M8mm Washer	4
2	 Adjustable Screw	2	3	 Double - ended Spanner	1
4	 Allen Key	1	5	 M6 Bolt Head Cap	21
6	 M8 Bolt Head Cap	6	7	 Leg Cap	4

Step by step assembly instructions

Note: Don't tighten nuts before every bolt is in place.

Don't tighten the bolts and nuts before all parts are aligned properly.

WARNING: At least two people should work together for easy assembly.

Step One

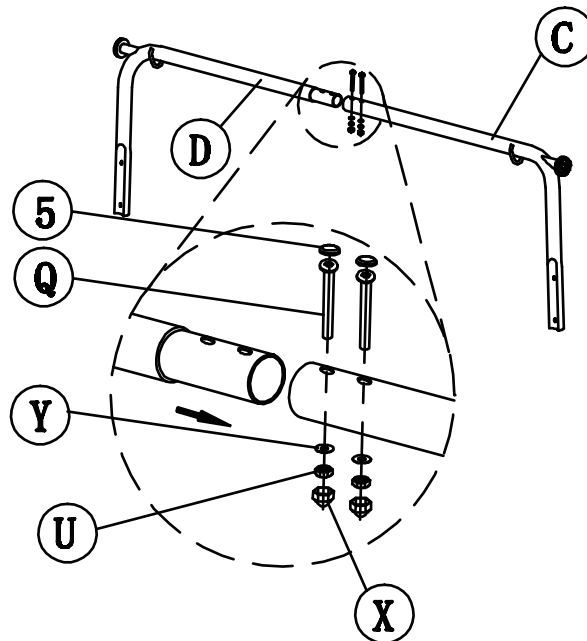

Step Two

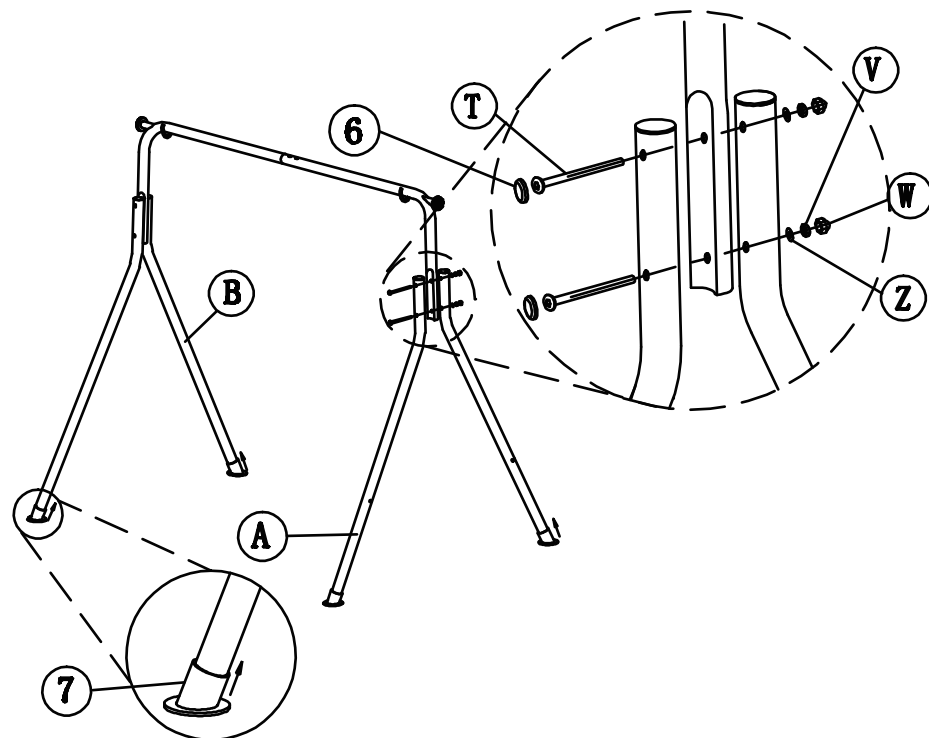

Step Three

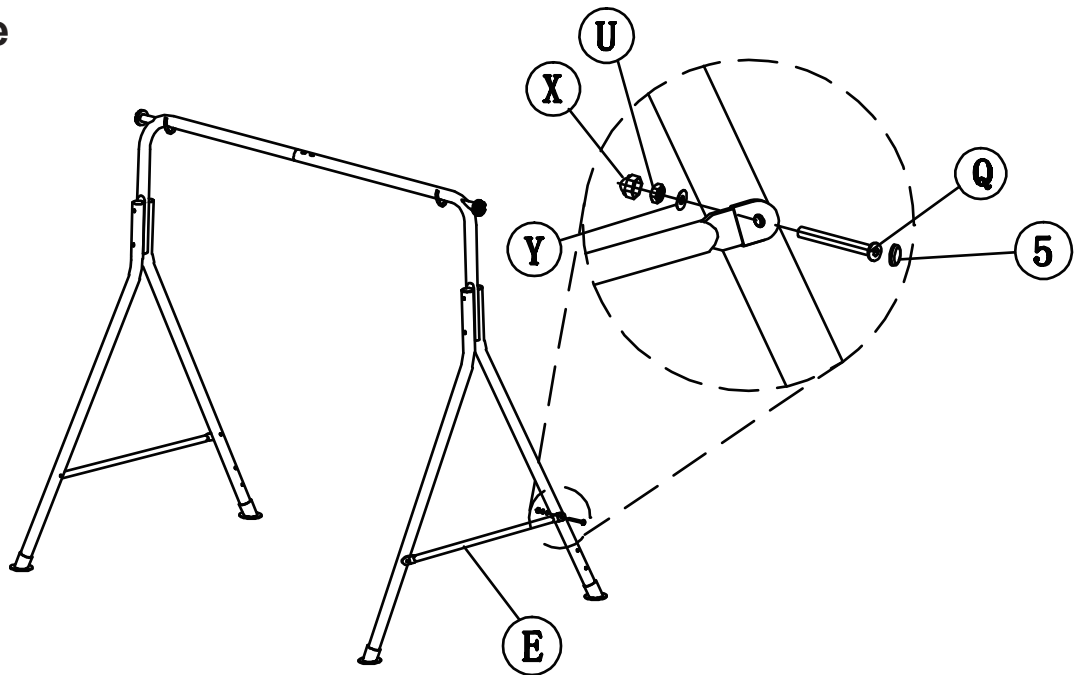

Step Four

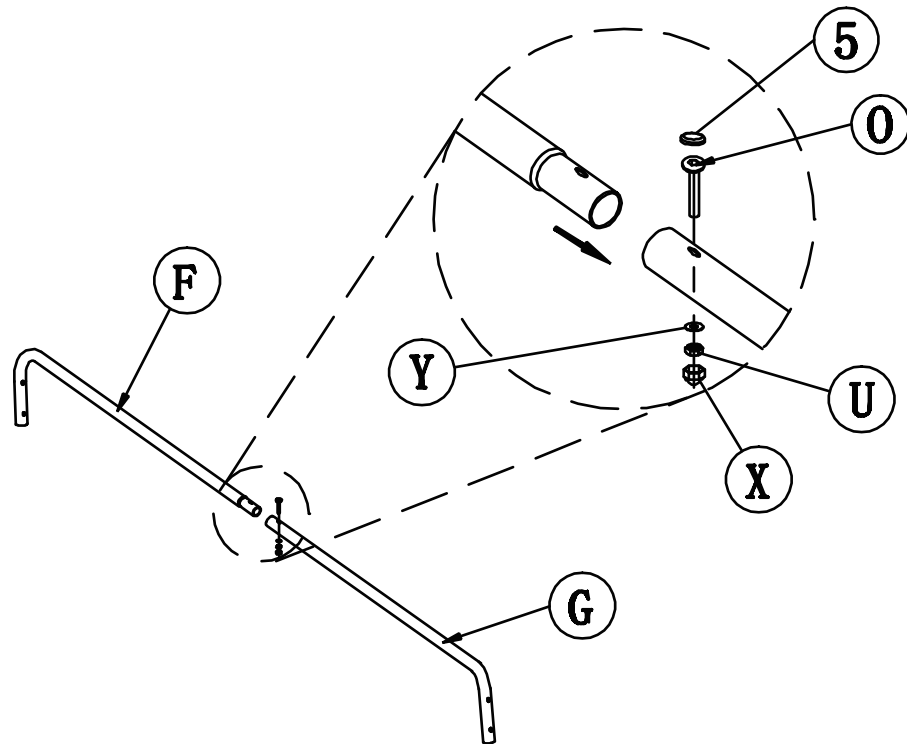

Step Five

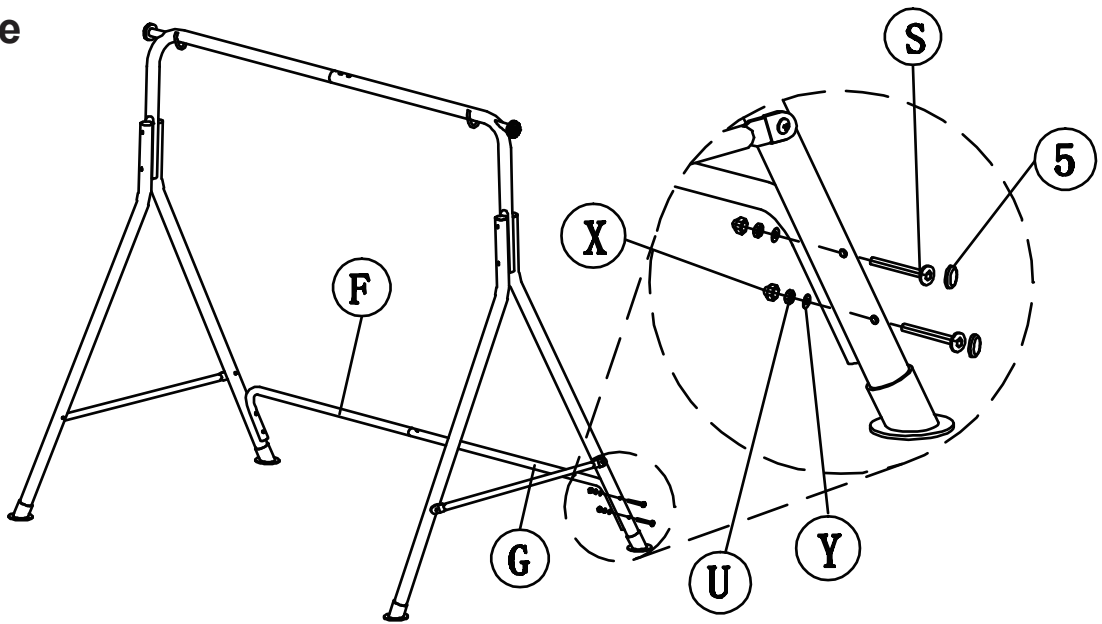

Step Six

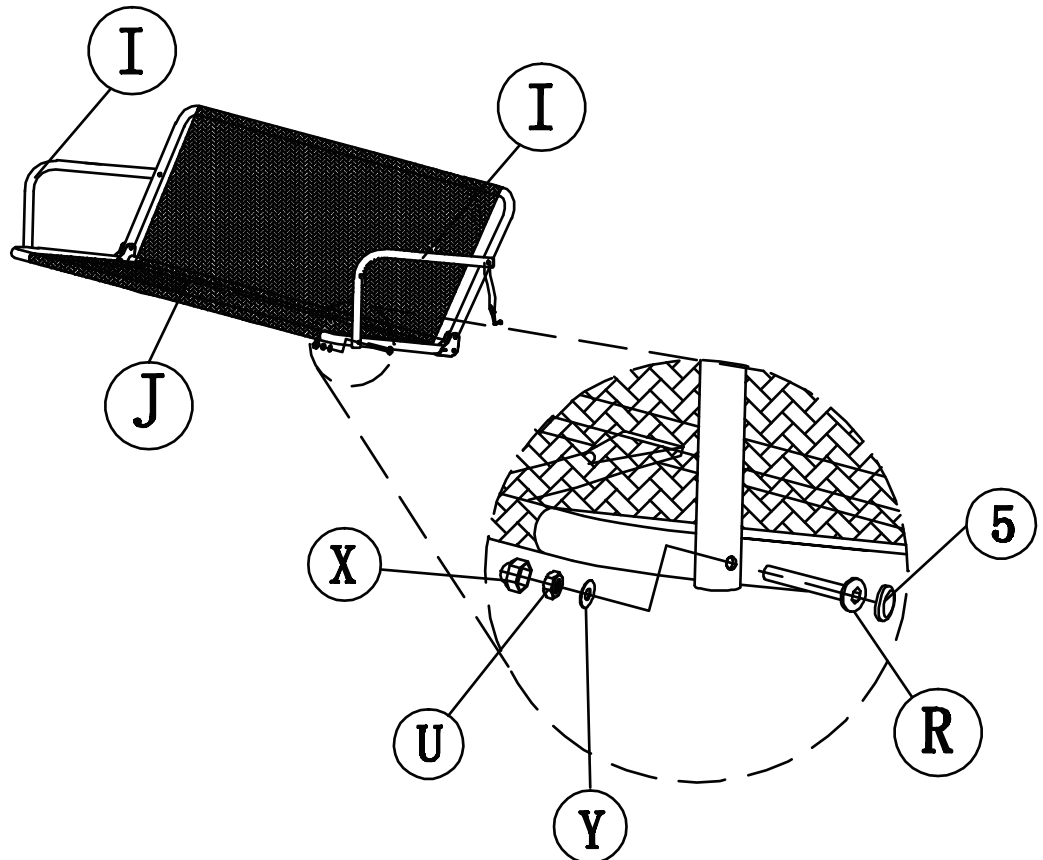

Step Seven

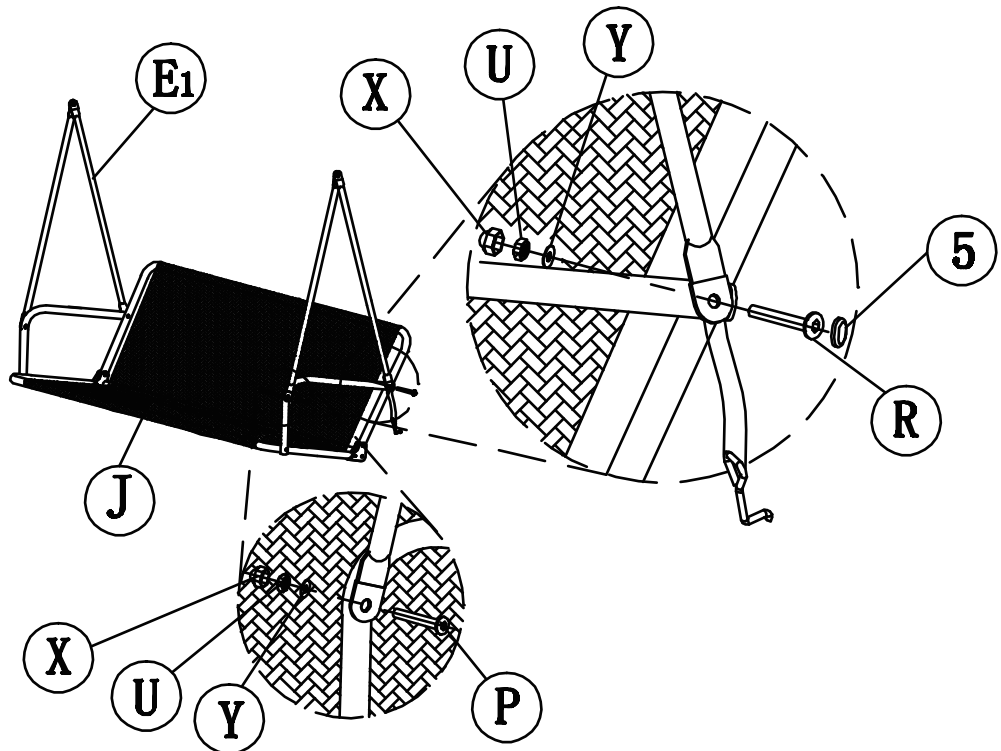

Step Eight

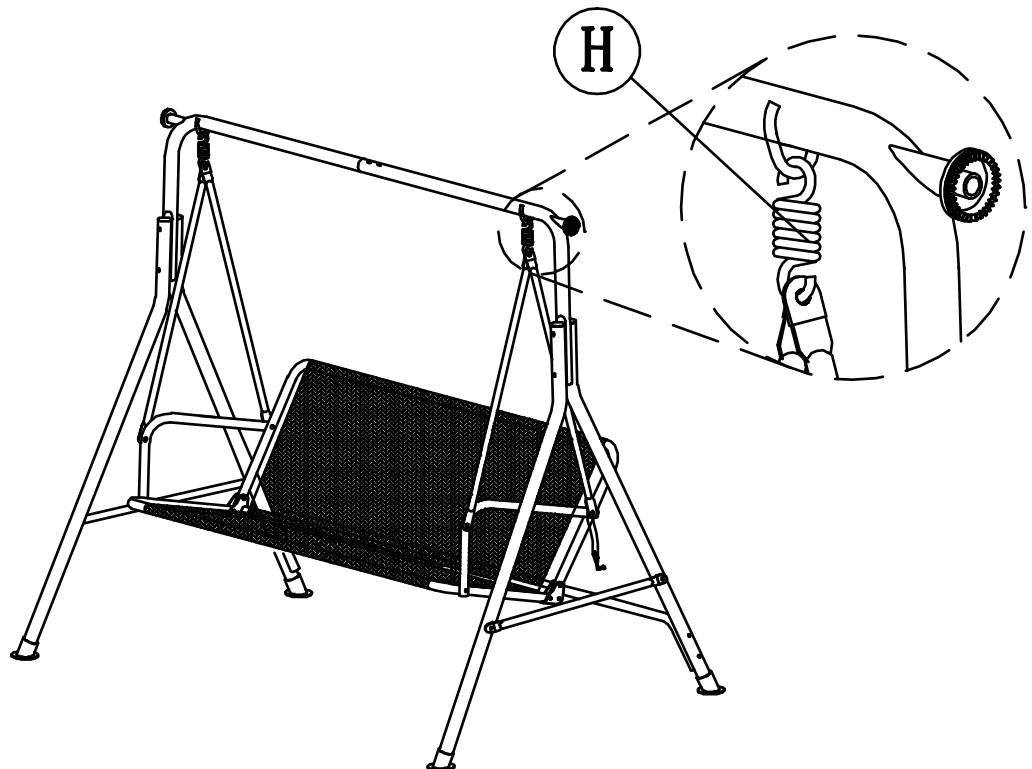

Step Nine

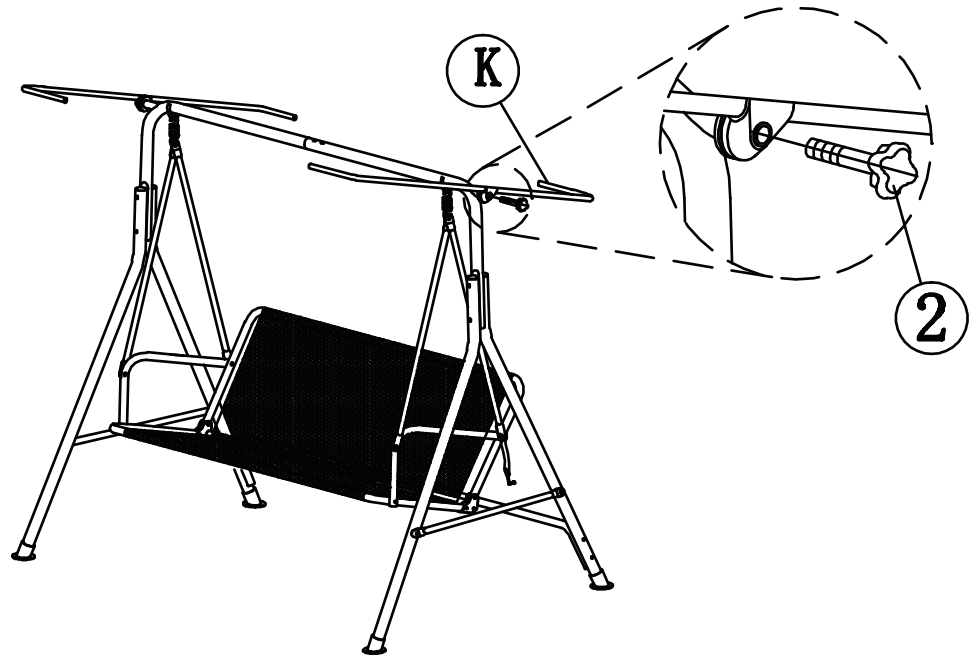

Step Ten

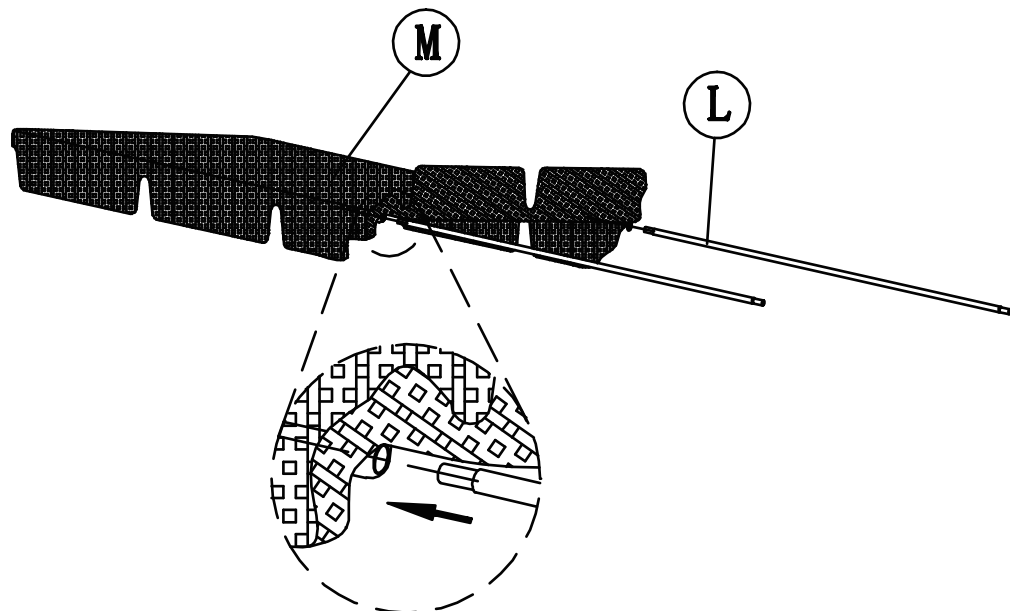

Step Eleven

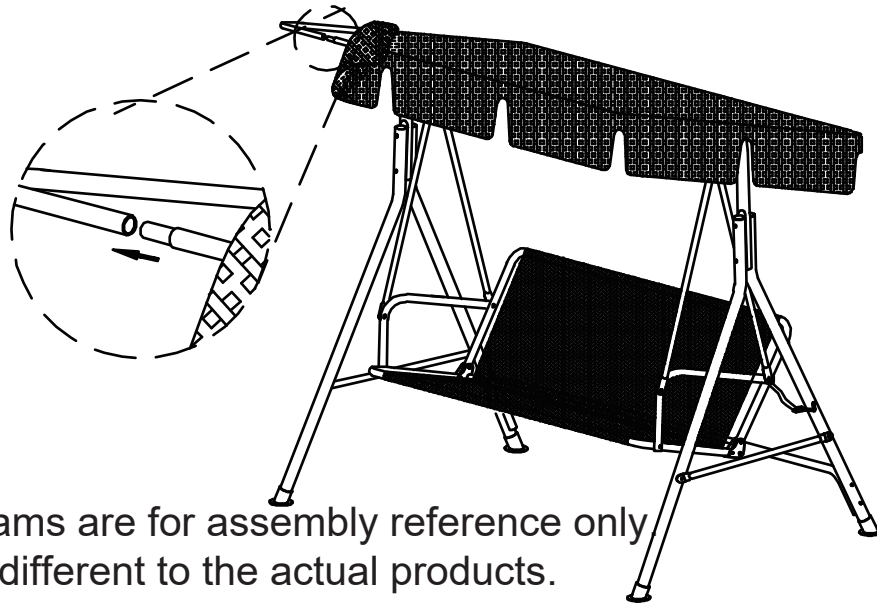

Note: The diagrams are for assembly reference only
It may be some different to the actual products.

Step Twelve



Warning:

Children and Kids should not use this product
without adult supervision and presence.

PLEASE KEEP THESE INSTRUCTIONS FOR FUTURE REFERENCE

www.royalcraft.co.uk