

Assembly Instructions for **BRISTOW 2-SEATER FUTON**

Design may vary but
basic assembly is the same

SAFETY WARNINGS

1. Before attempting to assemble or install this product read and follow the instructions in leaflet and on any attached labels!
2. **NEVER ALLOW CHILDREN TO PLAY WITH OR OPERATE THE FOLD OUT BED ACTION AND BEWARE OF THE DANGERS WITH MOVING PARTS WHICH CAN CAUSE ENTRAPMENT.**
3. **Routine Maintenance:**
Periodically check that all fixture and connectors are tight.
4. Do not stand hot products directly on the wood surface.
5. Mop up any spills immediately.
6. Surface of wood is not resistant to bleaches, acids, or other "aggressive" agents.
7. Never use substitute parts. Always contact the supplier for replacement parts:



Use 2 people and assemble unit close to its final position.

Kyoto Futons Ltd. Tel: 01778 380555 / Fax: 01778 380444



Before Starting Assembly

We suggest you spend a short time reading through this leaflet, then follow the simple step by step instructions. Some parts are viewed differently from the exploded drawing shown; this is for extra clarity.













To avoid scratching, we advise that assembly takes place on a protected surface.

Do not discard any of the packaging, until you have checked all the parts and fittings.



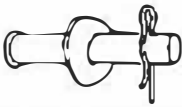



Because we constantly try to improve the quality of the components, occasionally they do differ slightly from the diagrams shown here. Any spare components can be thrown away once the assembly is complete if they are not needed. We reserve the right to change the specification of any piece of furniture without prior notice.

RECOMMENDED DOMESTIC USE	CARE AND MAINTENANCE	GENERAL INFORMATION CARE & MAINTENANCE	
Occasional <input type="checkbox"/>	 Avoid sharp objects	Usually regular cleaning with a clean dry cloth is sufficient, but for stubborn marks wipe over gently with a clean damp cloth. Never use strong detergents or abrasive cleaners as these may damage the surface finish of your furniture. Your sales receipt is your guarantee, please keep it in a safe place. We hope you are pleased with your new product and that it provides you with years of satisfaction and use. Thank you for shopping with us.	
Light <input type="checkbox"/>			 Avoid excessive force
General <input checked="" type="checkbox"/>			
Heavy <input type="checkbox"/>			 Wipe off with damp cloth

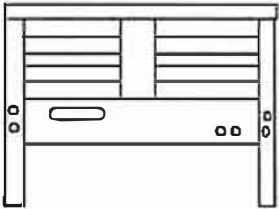
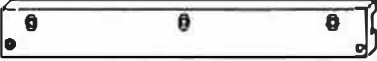
FITTINGS CHECKLIST

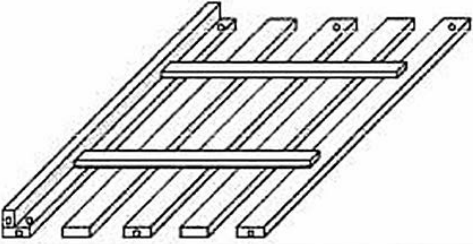
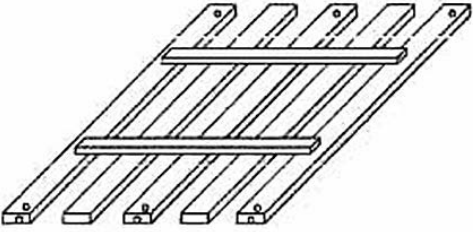
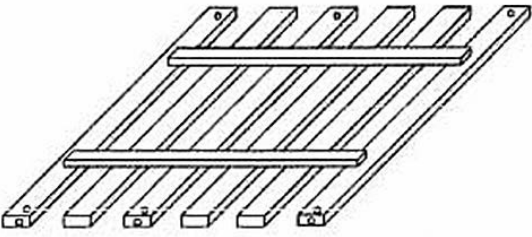
	CODE	DESCRIPTION	QTY
	F1	BOLTS M6 x 35mm	2
	F2	BOLTS M6 x 40mm	4
	F3	BOLTS M6 x 50mm	18
	F4	BOLTS M7 x 50mm	2
	F5	BOLTS M6 x 90mm	8
	F6	C/B SCREW 3.5 x 16mm	4
	F7	C/B SCREW M4 x 32mm	4
	F8	BARREL NUT M6 X 13mm	26
	F9	CLEVIS PIN	4
	F10	ROLLER	2
	F11	L BRACKET	2
	F12	M4 ALLEN KEY	1

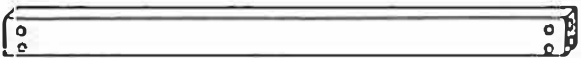
PARTS CHECKLIST

	Code	Qty	Description
	P1	2	Arms
	P2	2	Front Deck Side Panel
	P3	2	Middle Deck Side Panel
	P4	2	Rear Deck Side Panel
	P5	1	Front Deck
	P6	1	Middle Deck
	P7	1	Rear Deck
	P8	2	Leg
	P9	2	Stretcher Rails
	P10	2	Frame Support

Step 1

Assemble Side Panel to Front Deck

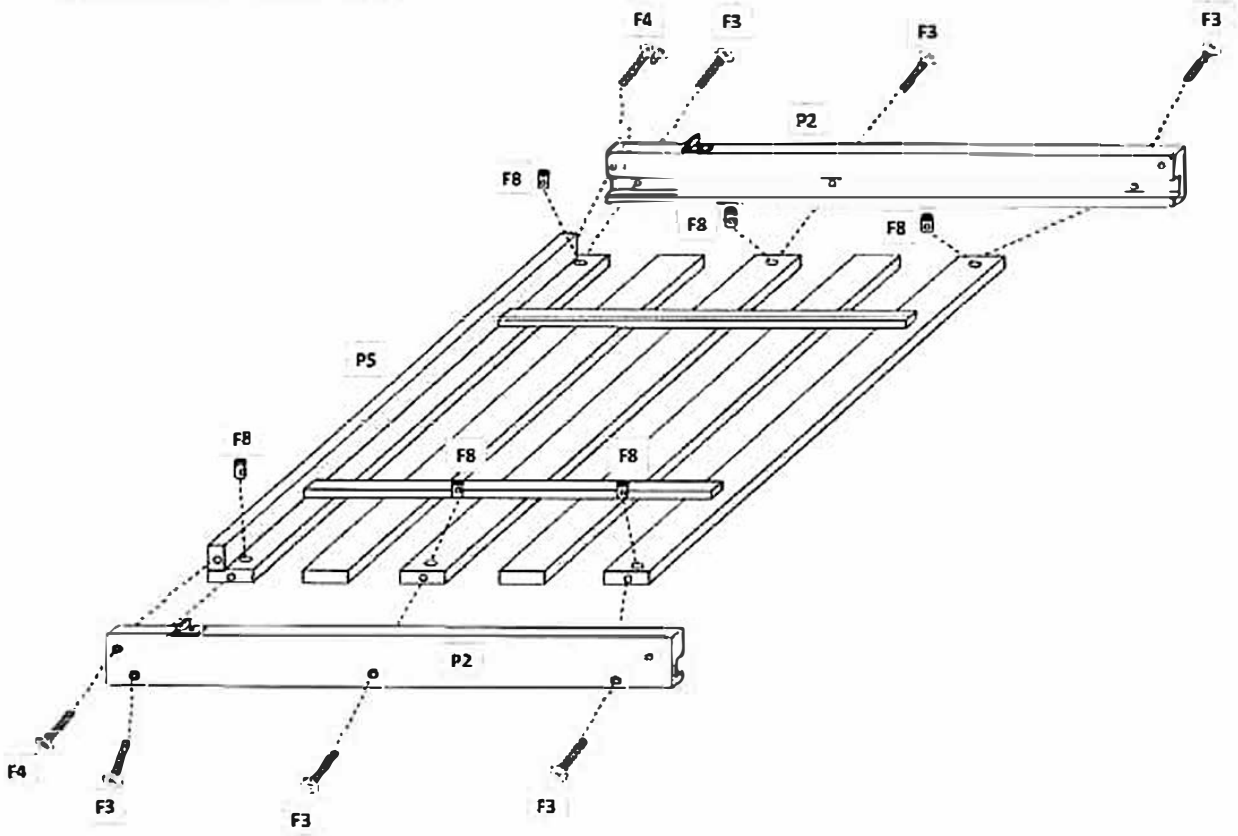

Step 2

Assemble Side Panel to Middle Deck and attach the roller to the side panel as shown.

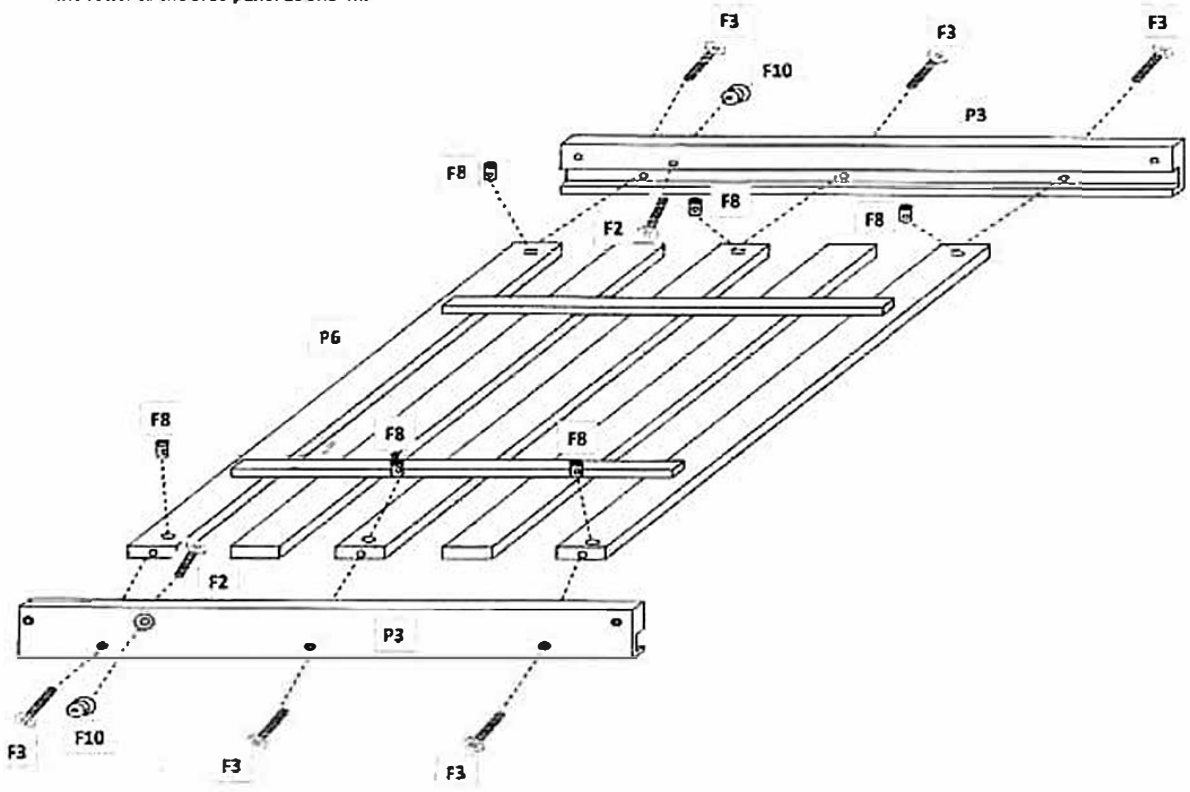

Step 3

Assemble Side Panel to Rear Deck.

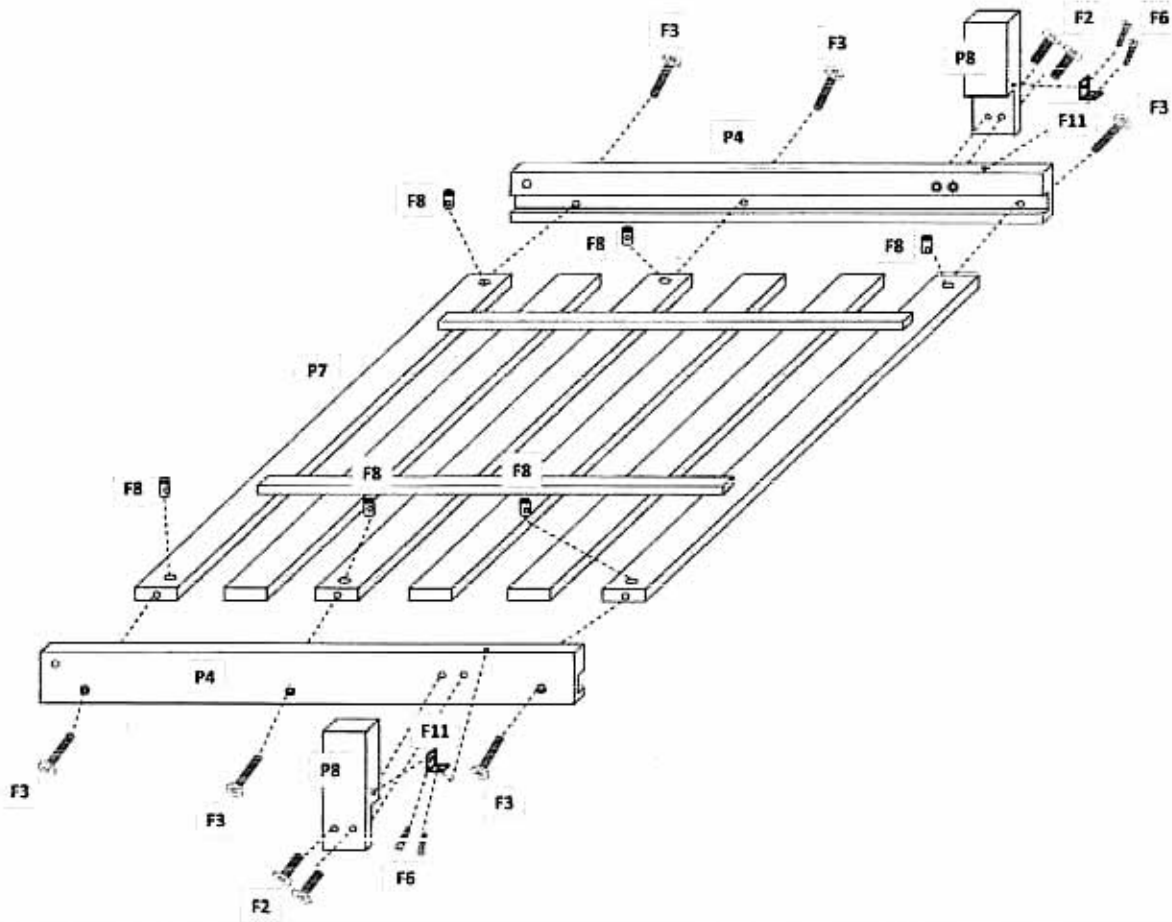

Step 4

Assemble stretcher rails to the Arm and screw the deck support as shown.
Do not tighten the bolts yet.

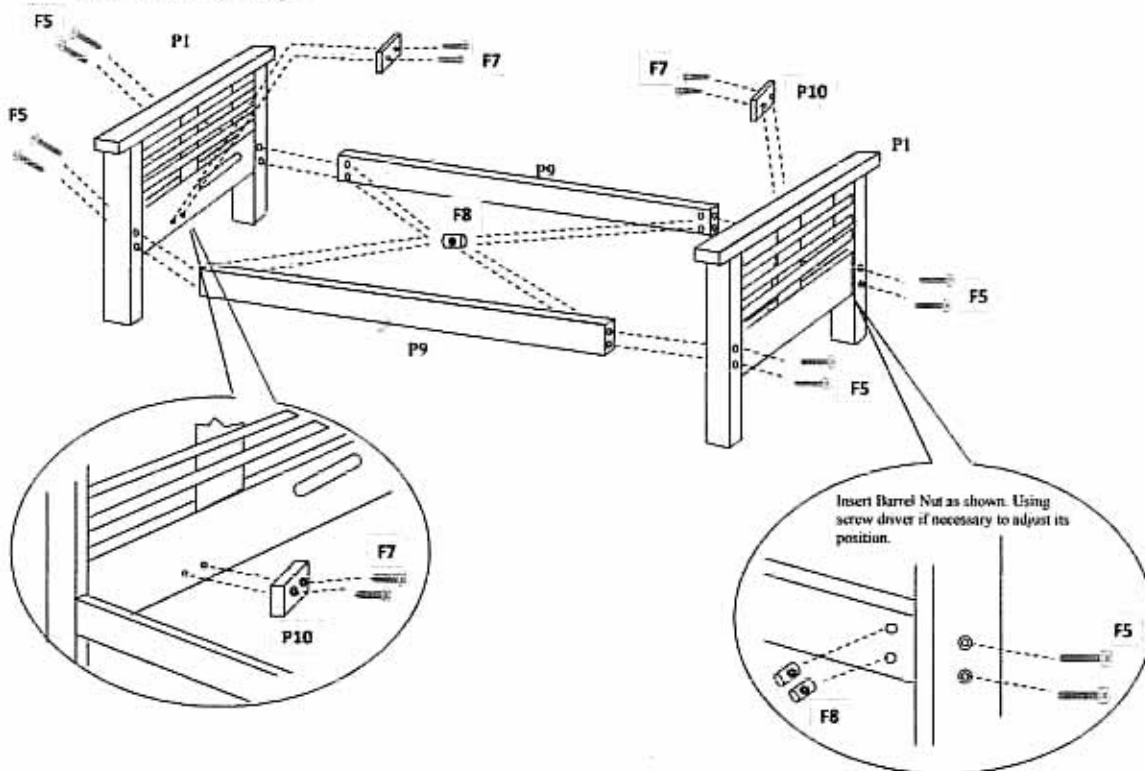

Step 5

Join the front deck with the middle deck with the clevis pin as shown below. Insert the clevis pin and spring clip as shown.

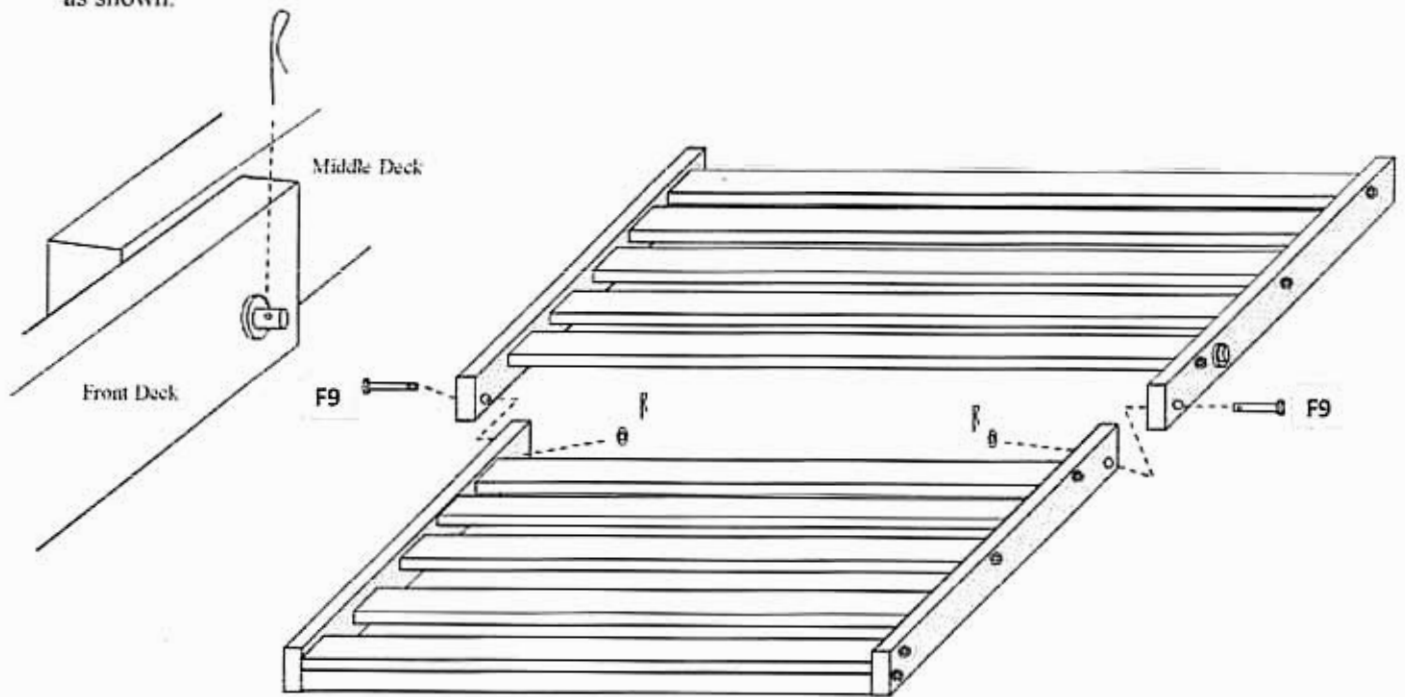

Step 6

Insert the deck assembled in STEP 5 orientated flat. Insert one side with the roller slotted into the groove found in the Arm. Then, gently lower the other end. Once decks are in place, tighten all the bolts.

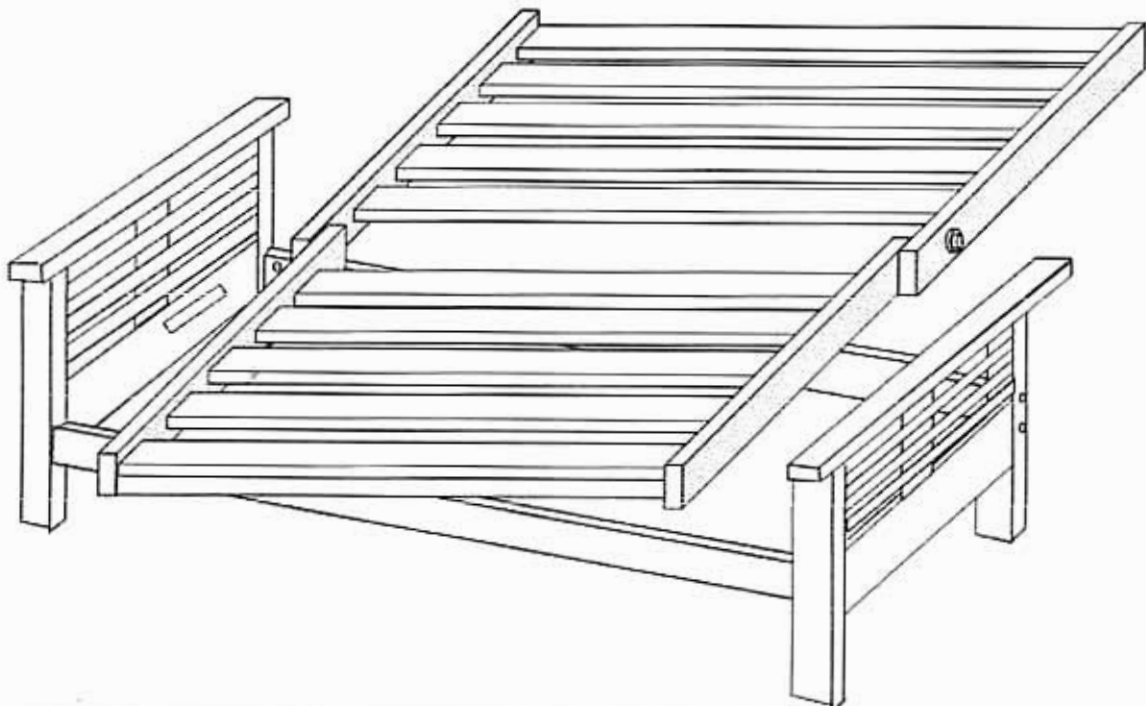

Step 7

Joint the Rear Deck into the end of middle deck with the clevis pin.

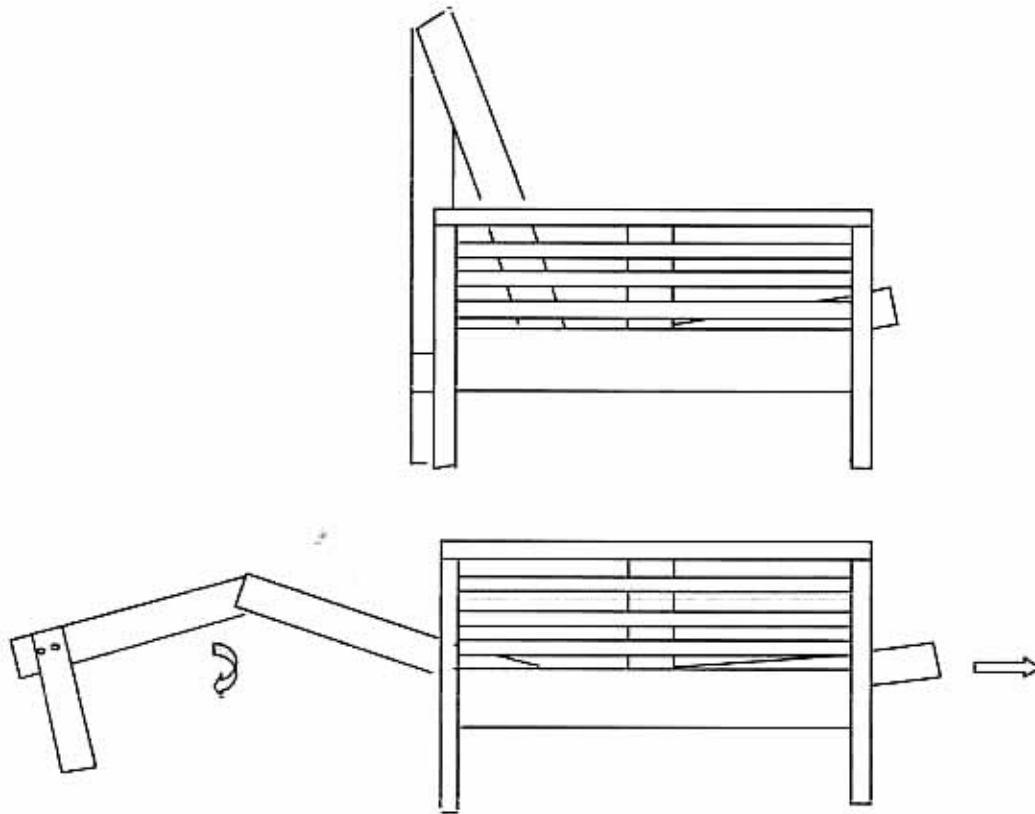
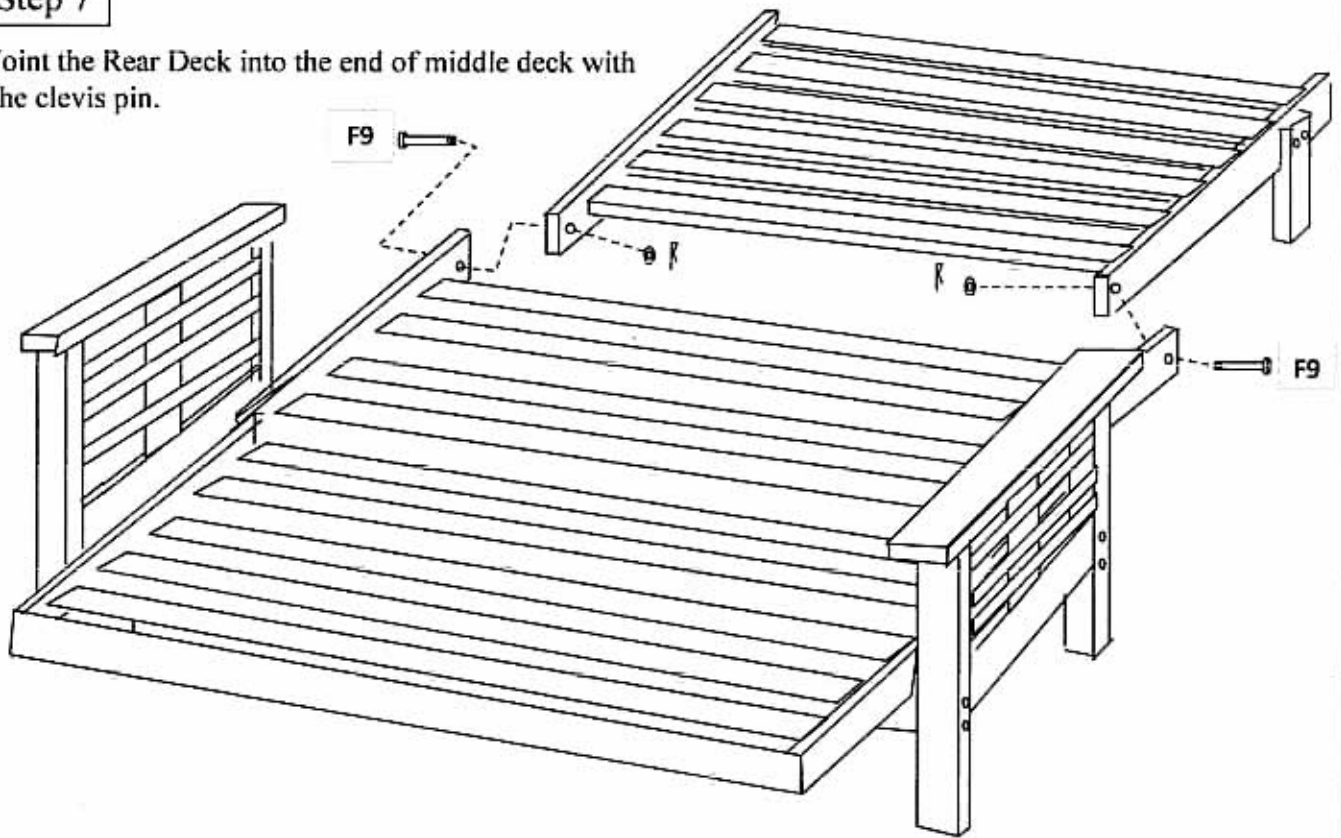

To convert into bed: Pull the rear deck gently down and then pull the front deck forward until it stops.
To convert back to lounge position, push the front deck inward and then lift the middle deck upward and push the rear deck toward the back of the arm.