

# Assembly Instructions

Falun Footstool

519294

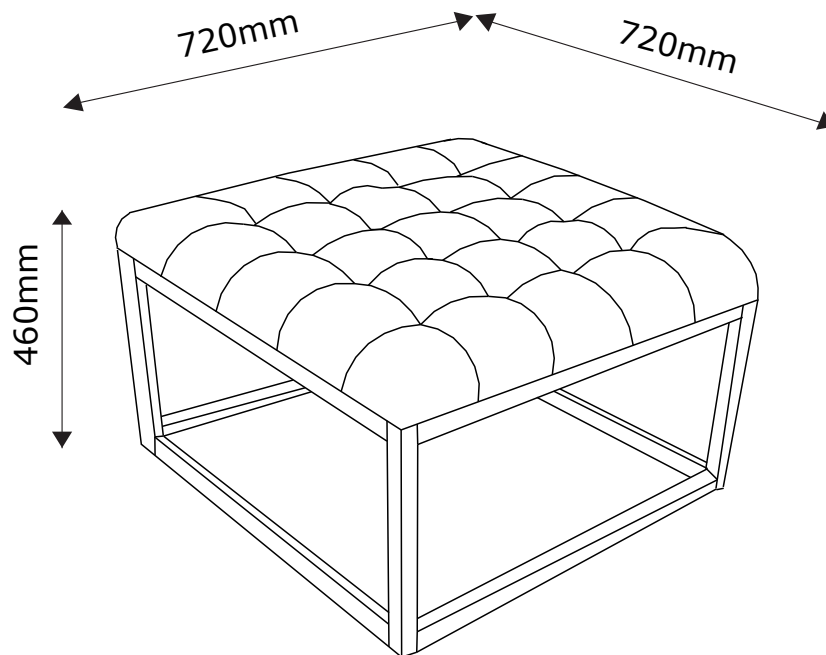

## **Keep these instructions for future reference**

Assemble the furniture on a soft level surface to avoid damaging the furniture or your floor.

We recommend furniture be assembled near where they will be placed, to avoid moving the product unnecessarily once assembled.

If there is a need to move the furniture, please remove all loose items and have extra hands to help lift the furniture to the desired location. Dragging the furniture will damage both the furniture and the floor.

Regularly check and re-tighten(if necessary) all bolts on furniture that you have assembled yourself.

## **Care and Maintenance of your Furniture**

Do not expose upholstered furniture to direct sunlight for long periods.

Do not place your upholstery in direct contact with strong heat.

Leave a 20-30cm gap between upholstery and radiators.

Avoid excessive wear and tear on your upholstery.

Do not allow children to jump up and down on the upholstery.

Avoid allowing pets on the upholstery as their claws may cause damage to the cover.

When your new upholstery arrives, you may notice that some of the cover may have been creased or squashed during transit. This can be simply corrected by gently patting the cover/foam back into shape to re-distribute the foam and reshape the covering.

## **Cleaning Advise**

For light daily cleaning, use a clean, damp cloth(not wet).

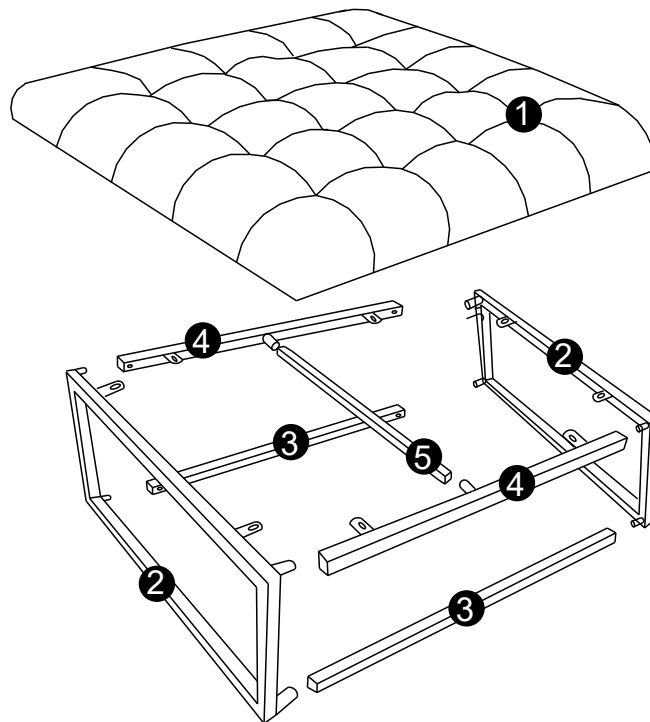

In case stronger cleaning is required, use only detergent specially recommended for your furniture.

# PARTS LIST

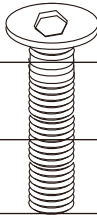
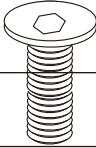

NO	PARTS LIST	QTY
(1)	STOOL TOP	1
(2)	METAL FRAME	2
(3)	METAL TUBE	2
(4)	METAL TUBE WITH TABS	2
(5)	METAL TUBE	1

# HARDWARE LIST

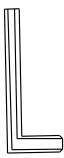
3cm			
2cm			
1cm			
0cm			
	<b>8x</b> M6x25mm	<b>10x</b> M6x16mm	<b>8x</b>
	<b>A</b> BOLT	<b>B</b> BOLT	<b>C</b> FLAT WASHER
			<b>8x</b>
			<b>D</b> SPRING WASHER
			<b>1x</b>
			<b>E</b> ALLEN KEY

# 1

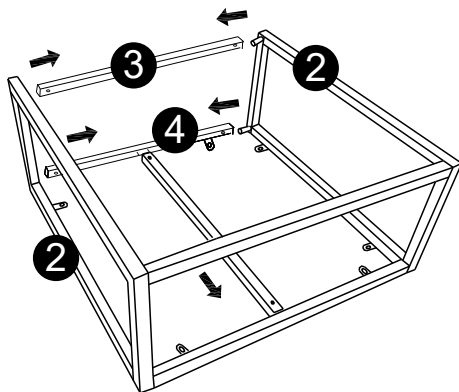
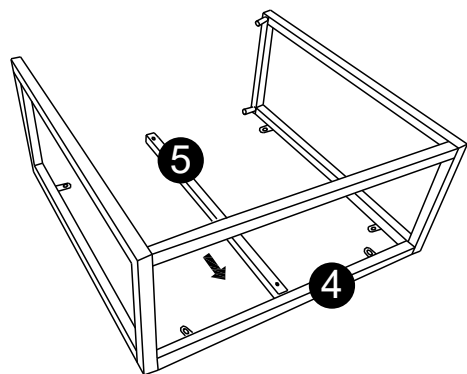
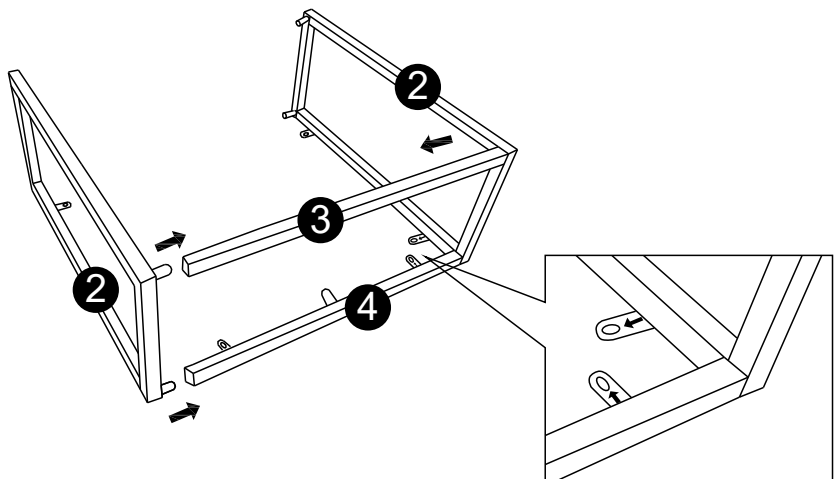

Please make sure metal parts at this corner are with arrows.

# 2

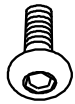

M6x16mm

Bx10



Ex1

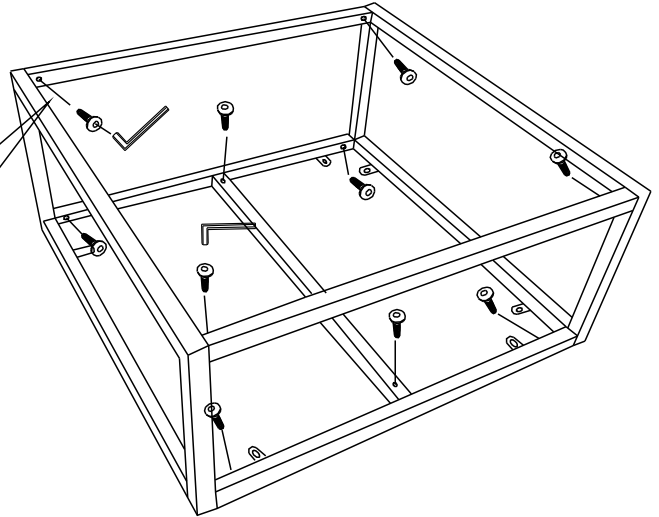
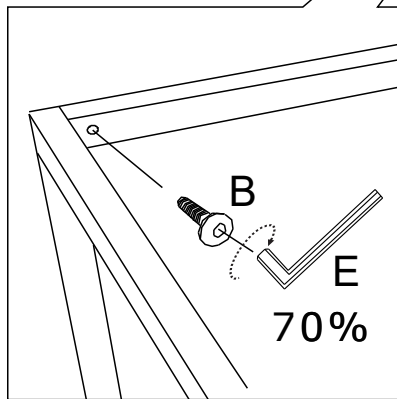
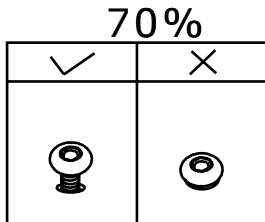

# 3

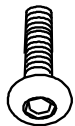

M6x25mm

Ax8



Cx8



Dx8



Ex1

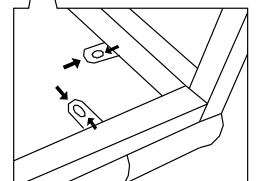
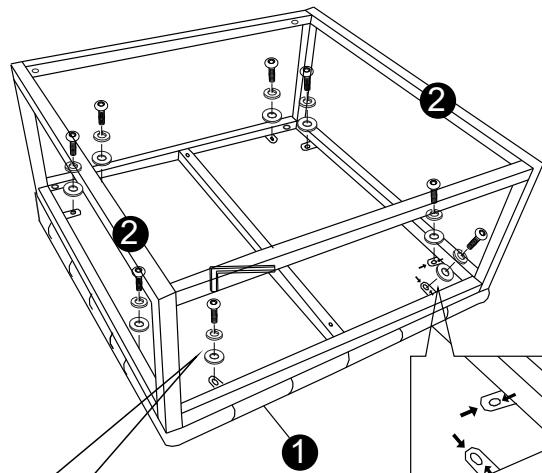
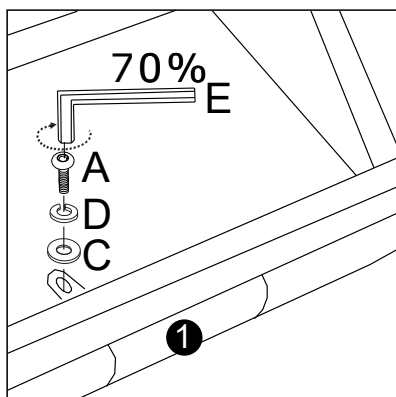
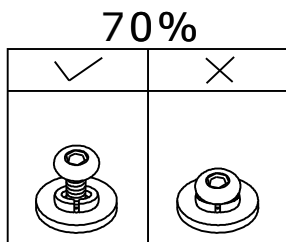

Please make sure the arrows on the parts point toward each other before installing.

# 4

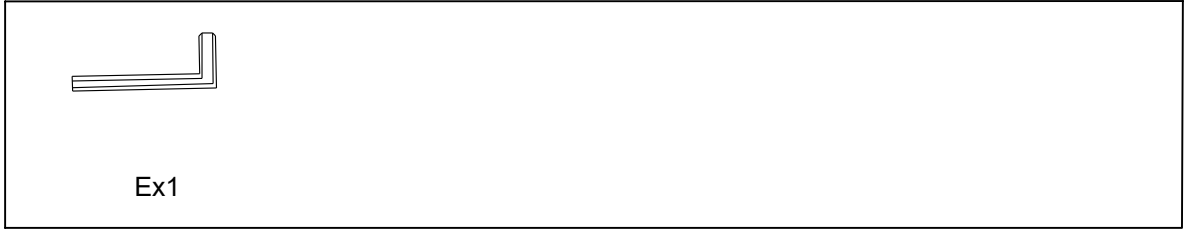

100%

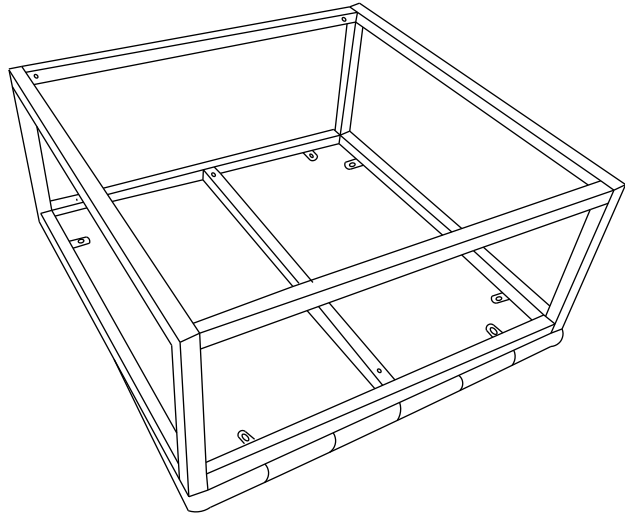
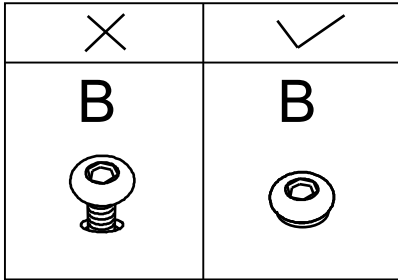

100%

