

iF 40
Roller Pizza Moulder



OPTIONS AND ACCESSORIES

(with surcharge)

- Pedal drive

EXTERNAL CONSTRUCTION

- Structure in stainless steel
- Pizza rollers in teflon
- Equalizer and shoots in stainless steel
- Transparent protections
- Flat push-button panel on front side

INTERNAL CONSTRUCTION

- Electric motor
- Belt drive
- Reduction set with globoidal screw
- The transmission rotating parts are assembled on self-lubricate ball bearings
- Electric system with low-tension auxiliary circuits

FUNCTIONING

- Dough cold rolled by mean of two rollers couples
- Adjustable thickness between rollers
- Adjustable equalizer to dough rotation
- Possibility to roll different food elements

STANDARD EQUIPMENT

- Rollers
- Equalizer
- Dough scaper
- Transparent protections



MORETTI FORNI S.P.A.

www.morettiforni.com

marketing@morettiforni.com

Via A.Meucci, 4 - 61037 Mondolfo (PU) ITALIA

Tel. +39.0721.96161 - Fax +39.0721.9616299



iF 40

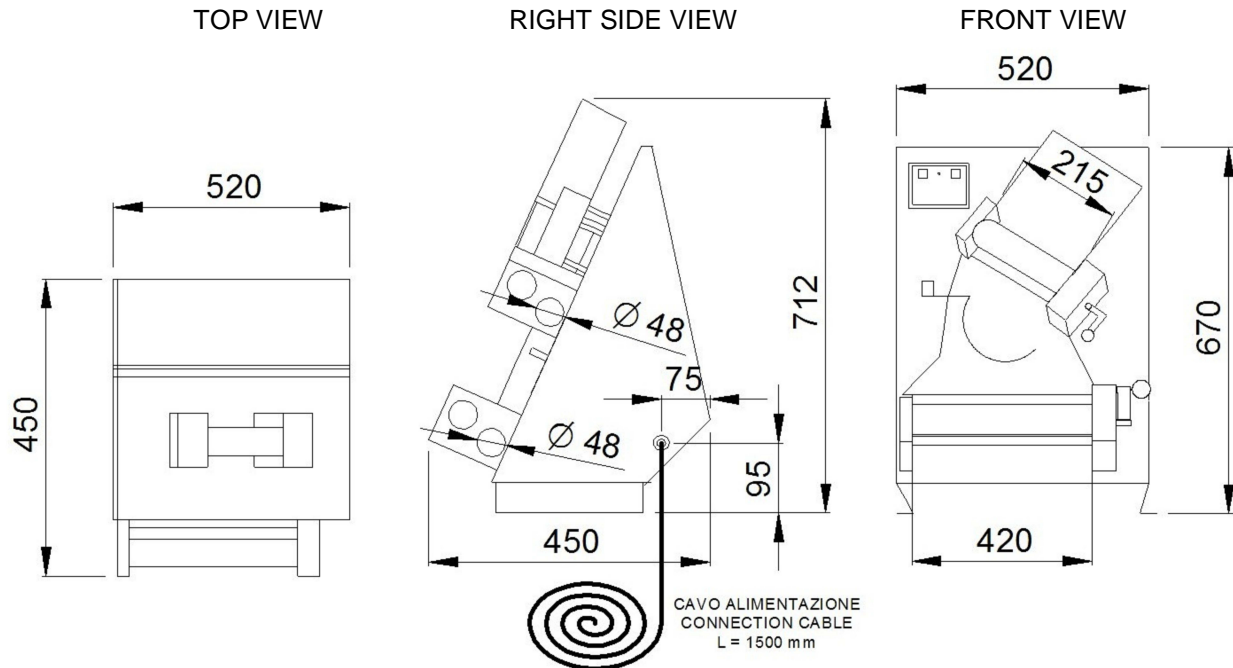

Nota: The dimensions indicated in the views are in millimetres

SPECIFICATIONS

Roller pizza moulder realized to resolve problems for formation round dough for pizza, focaccia, pies, bread etc.. The pizza moulder allows to economize times and above all don't need specialized staff. The cold working don't change dough peculiarità, the thickness and width of dough are adjustable. Thickness dough adjustable by mean of two rollers couples until max 5mm. The adjustable equalizer permits authomatic rotation to obtain the round shape. The lower rollers are equipped with dough scraper, easy disassembly for cleaning. Structure in stainless steel, pizza rollers in teflon, transparent protections. The machine has an electric motor provided of belt drive and two reduction set with globoidal screw.

TECHNICAL FEATURES

DIMENSIONS

Ext height	712mm
Ext depth	450mm
Ext width	520mm
Upper rollers width	215mm
Lower rollers width	420mm
Rollers diameter	48mm
Weight	45kg

SHIPMENT INFORMATIONS

Packed machinery:	
Max height	475mm
Max depth	830mm
Max width	620mm
Weight	(45+5)kg

FEEDING AND POWER

<i>Standard feeding</i>
A.C. V230 1N 50Hz
Power 0,375kW
On request frequency 60Hz

MACCHINA CAPACITY

Dough weight	min 80gr/max 400gr
Pizza diameter	○ from 14 to 40cm