

iM 25

Spiral kneading machine for pizza, pastry and bakery



EXTERNAL CONSTRUCTION

- Structure in powder painted stainless steel
- Spiral, basin, dough-breaker and safety grille in stainless steel
- Thick frame to avoid vibrations in every working phase
- Push-button panel on right side
- Machinery on rotating wheels

INTERNAL CONSTRUCTION

- Motorization with bath oil motoreducer
- Chain drive
- Rotating transmission parts are assembled on self lubricating ball bearings.
- Electrical equipment with low-voltage auxiliary circuit
- Safety device for grille

OPERATION

- Dough homogeneity and oxygenation by the combined rotating movement of the utensil and basin
- The shape of the spiral assures a low and constant temperature of dough during the working
- Possibility to mix maximum 25 Kg dough in few minutes

STANDARD EQUIPMENT

- Spiral
- Basin
- Dough-breaker
- Rotating wheels
- Timer

OPTIONS AND ACCESSORIES (WITH SURCHARGE)

- Two speeds machine

MORETTI FORNI S.P.A.

www.morettiforni.com

e-mail: marketing@morettiforni.com

Via A.Meucci, 4 - 61037 Mondolfo (PU) ITALIA

Tel. +39.0721.96161 - Fax +39.0721.9616299



iM 25

TOP VIEW

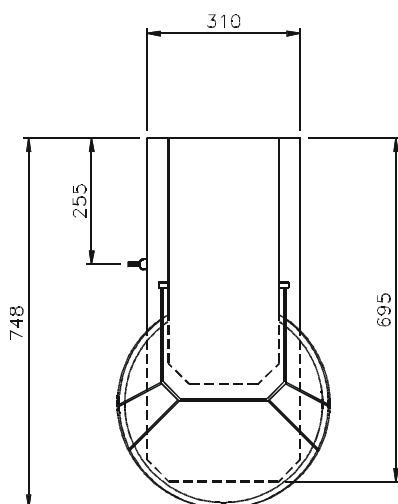

REAR VIEW

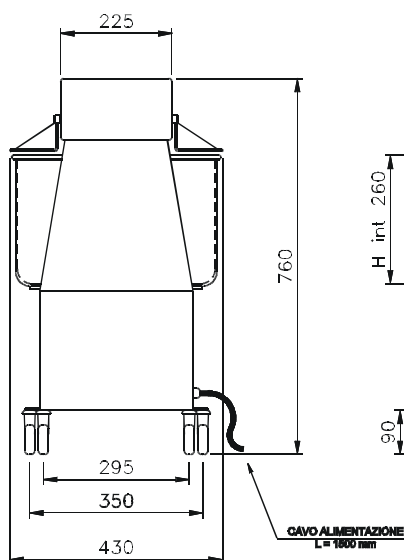

RIGHT SIDE VIEW

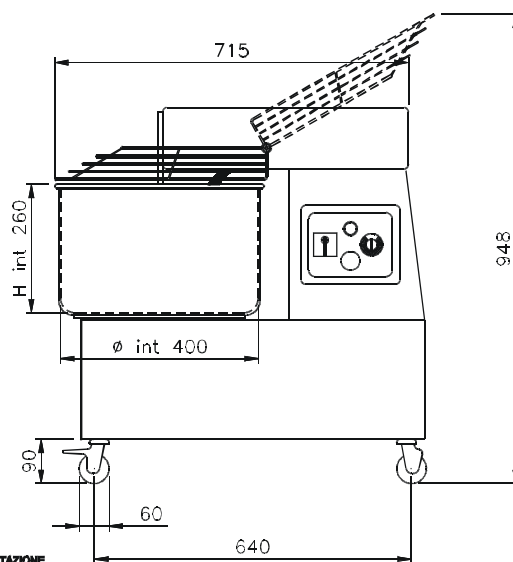

Note: The dimensions indicated in the views are in millimetres

SPECIFICATIONS

Spiral kneading with firm head, ideal for small spaces with rotating wheels. To the construction are used height quality and robustness materials. Thanks to the particular shape of spiral and to the rotating movement of the utensil combined with that of the basin, the spiral kneading, gives possibility to mix in few minutes 25 Kg dough, and assures very good homogeneity and oxygenation. The model assure constant temperature of the dough from beginning to end working, so eliminate the danger of incidental overheating. The transmission system is particularly silent because all parts are assembled on watertight ball bearings with bath oil motoreducer, free maintenance. The machinery is provided of indispensables safety devices.

TECHNICAL FEATURES

DIMENSIONS

External height	760 mm
External depth	748 mm
External width	430 mm
Weight	95 kg

BASIN CAPACITY

Capacity (dough)	25 kg
Capacity (volume)	33 l
Basin internal capacity	400 mm
Basin internal height	260 mm
Spiral diameter	22 mm

SHIPMENT INFORMATIONS

Packed machinery:	
Max height	840 mm
Max depth	935 mm
Max width	525 mm
Weight	(95+5) kg

FEEDING AND POWER

<i>Standard feeding</i>	
A.C. V 400 3 50Hz	Power 1.1 kW
<i>Feeding on request</i>	
A.C. V230 3 50 Hz	Power 1.1 kW
A.C. V230 1N 50 Hz	Power 1.1 kW

On request frequency 60 Hz

Two speeds machine not disposal with V230 1N