

FANCY ✕ TIGER ✕ CRAFTS

ONE HOUR TOP

SIZES XS/S, M/L, XL/XXL | BEGINNER



WWW.FANCYTIGERCRAFTS.COM

designed by Amber Corcoran

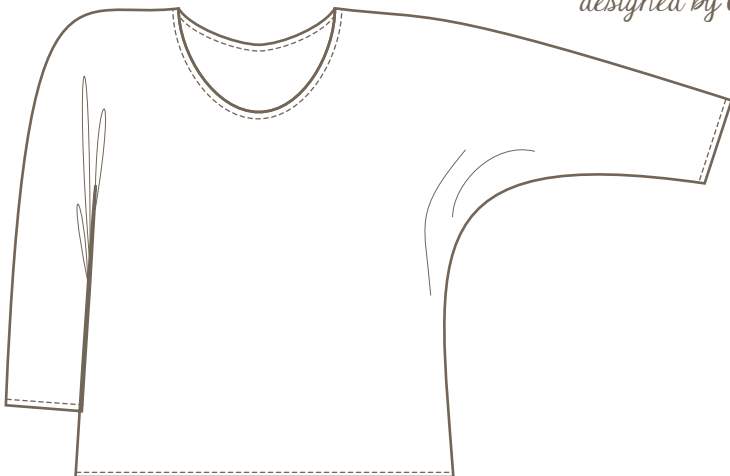

This top can be made in the blink of an eye. With just two pieces and simple construction, it is as easy as can be. Use a serger and a sewing machine fitted with a twin needle for a professionally finished garment. You'll be wearing your new shirt in no time!

[#onehourtop](#)

all rights reserved © 2014 Fancy Tiger Crafts for personal use only

ONE HOUR TOP

designed by Amber Corcoran

RECOMMENDED FABRIC

Medium weight knit fabric.

SIZES

XS/S M/L XL/XXL

BODY MEASUREMENTS (INCHES)

Bust	32-34	36-39	42-45
Waist	25-27	29-32	35-38
Hips	35-37	39-42	45-48

FABRIC REQUIRED (YARDS)

56"+ wide	1 ³ / ₄	1 ³ / ₄	1 ³ / ₄
------------------	-------------------------------	-------------------------------	-------------------------------

FINISHED MEASUREMENTS

Bust	46	49	52
High Hip	38	42	47
Length	23	24	25

finished length is measured from shoulder to hem

ADDITIONAL MATERIALS NEEDED

Printer, tape, sewing machine, twin machine needle, serger, coordinating thread, fabric shears, pins, marking tool, measuring tape, iron, sewing gauge.

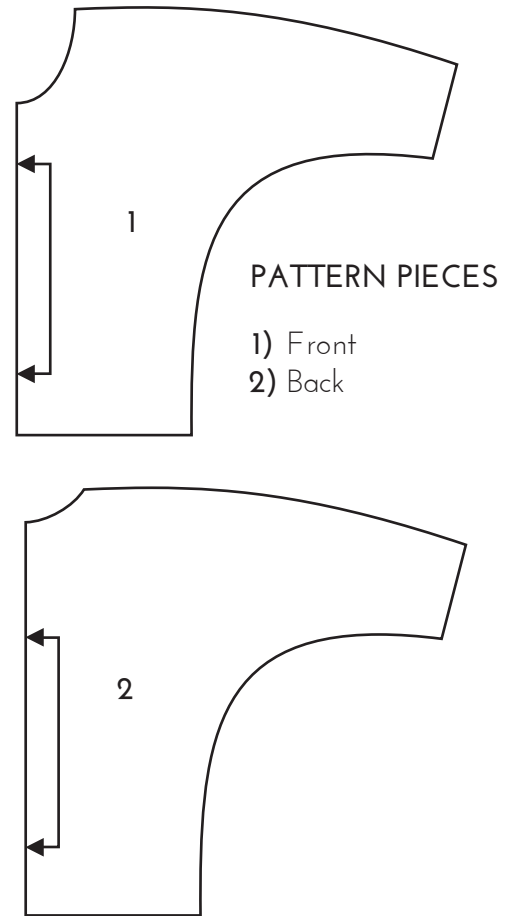

BEFORE YOU BEGIN

Print & assemble your paper pattern pieces. When printing, make sure to turn off scaling in your printer settings. You can check this by measuring the 1" square on the first page of your printed pattern. Trim left side and bottom of each page and tape together according to the assembly guide, lining up edges and matching triangles.

Wash, dry & press your fabric before cutting out your pieces. Launder it the way in which you will care for your finished garment. This will ensure that your garment fits the same every time you wear it.

Measure yourself at bust, waist and hip, and use the chart to select your size. The One Hour Top is designed to fit with some positive ease. If your bust measures to a different size than your waist and/or hips, you can most likely follow your hip size for this pattern. Check the chart for finished garment measurements to see the actual measurements of the finished top.

For **lengthening or shortening** the pattern, check the finished length measurement on the chart. If you would like to adjust the length of your garment, you can alter your Front(1) and Back(2) piece by adding the amount you would like to the bottom hem.

CUTTING INSTRUCTIONS

Trace both pattern pieces onto your fabric before you begin cutting.

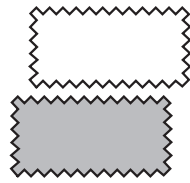

wrong side of knit
right side of knit

Pattern Pieces

- 1) Front - cut 1 on the fold
- 2) Back - cut 1 on the fold

CUTTING LAYOUT

56" + Wide Fabric - All Sizes

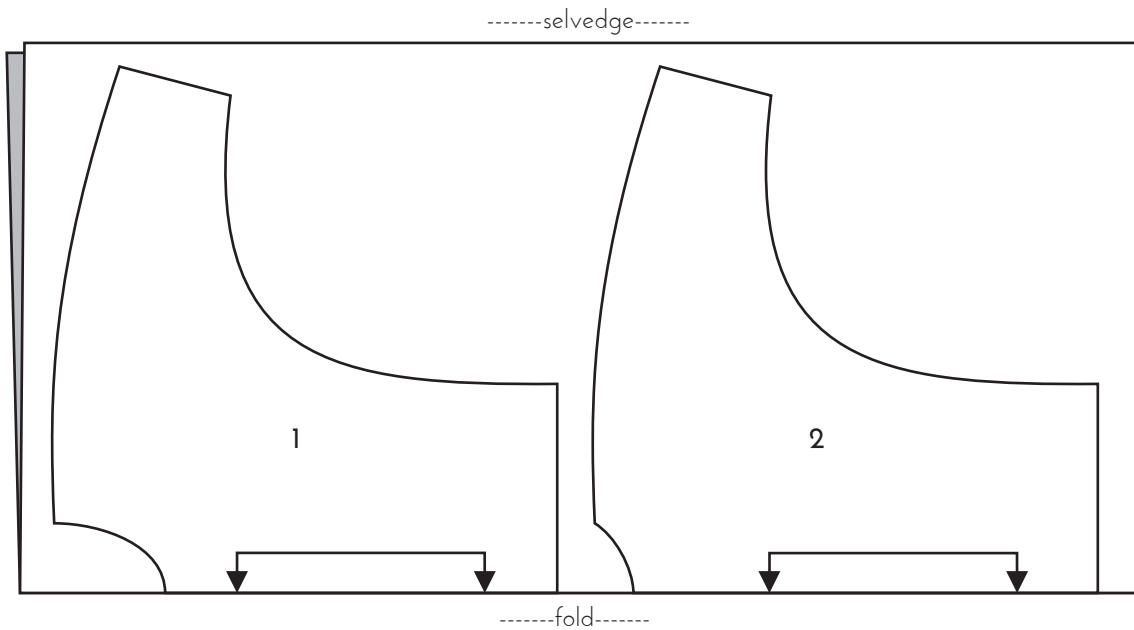

SEWING INSTRUCTIONS

Seam allowance is 1/2" for all seams.

1: Serge Shoulders

With right sides together, pin Front to Back at both shoulder seams, and serge together. (If you are using a regular machine you can use a narrow zig-zag stitch or a stretch stitch.)

Press seam allowance towards back of garment.

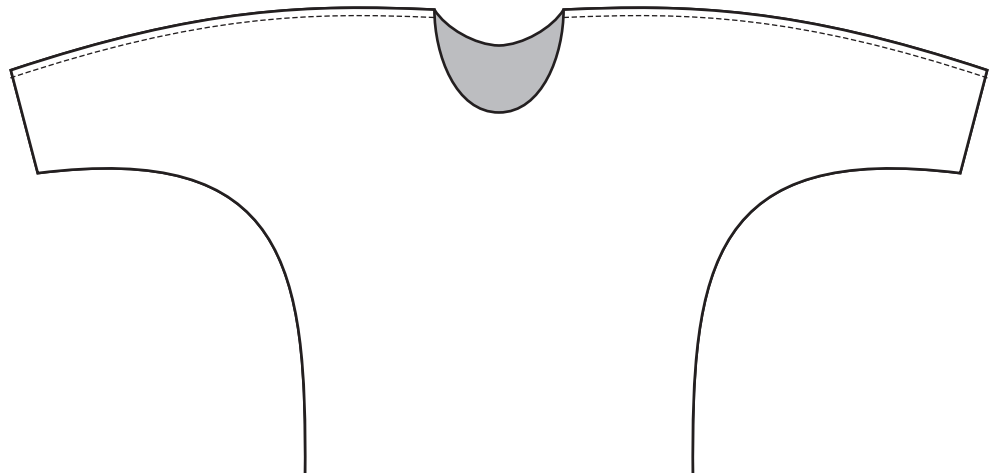

2: Serge Side/Underarm Seams

With right sides together, pin Front to Back at both side seams, and serge together. Press seam allowance towards back of garment.

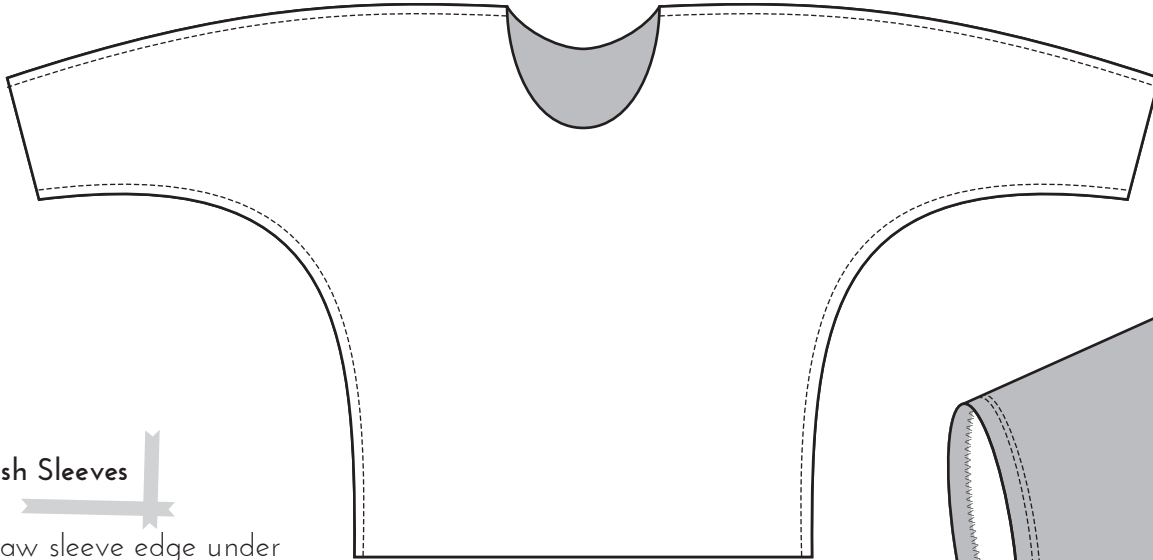

3: Finish Sleeves

Press raw sleeve edge under $\frac{1}{2}$ ", to inside of sleeve. With a twin needle in your sewing machine, and the right side of your garment facing out, stitch the sleeve hem at $\frac{3}{8}$ ", catching the raw edge of your sleeve to finish. Repeat for other sleeve.

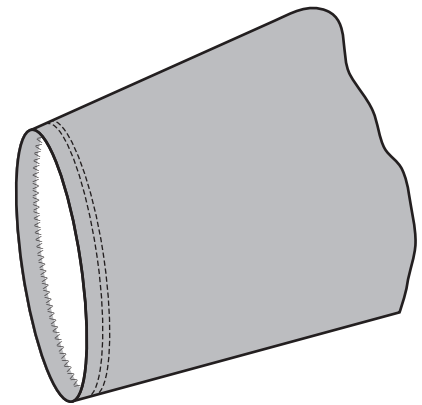

4: Finish Neck and Bottom Hem

Press raw neck edge under $\frac{1}{2}$ ", to inside of collar. With your twin needle, stitch the neckline at $\frac{3}{8}$ " to catch the raw edge, just like you finished your sleeves. Now repeat at the bottom hem in the same way.

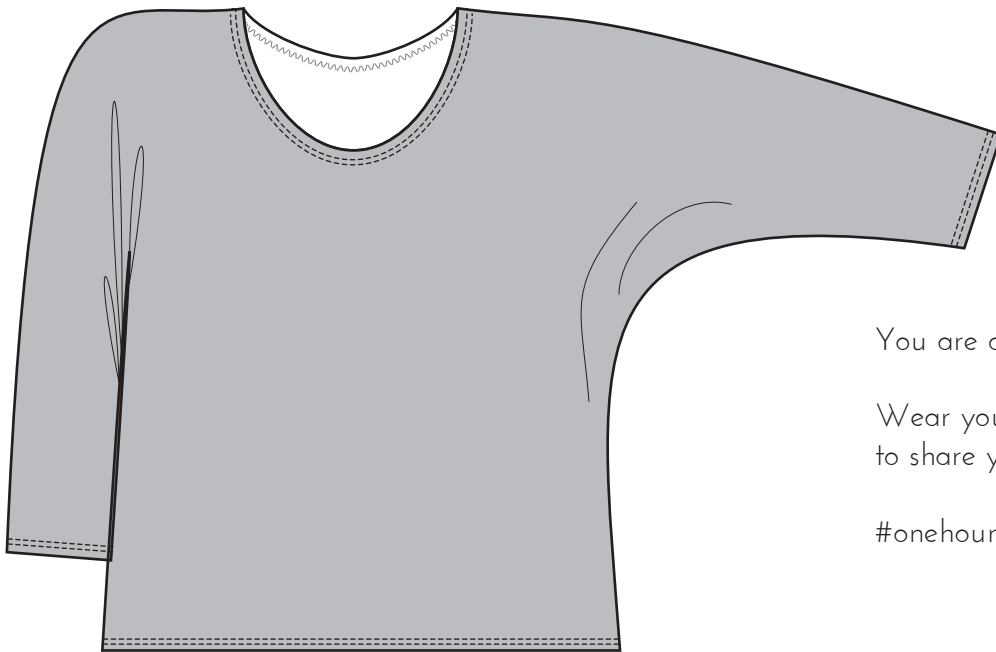

You are all finished! That was a breeze!

Wear your One Hour Top with pride and be sure to share your creation with us!

#onehourtop

FANCY ✖ TIGER ✖ CRAFTS

Fancy Tiger Crafts is a revolutionary shop in Denver, Colorado that specializes in craft supplies and classes for the modern crafter. If you are ever in Denver, we'd love to see you! Visit us at our shop at 59 Broadway just a couple miles south of downtown. Wear your One Hour Top to show off to us when you visit!

You can also visit us online at fancytigercrafts.com

Thanks for your craft love and support!

*xoxo,
Amber & Faimé*

Assembly Guide

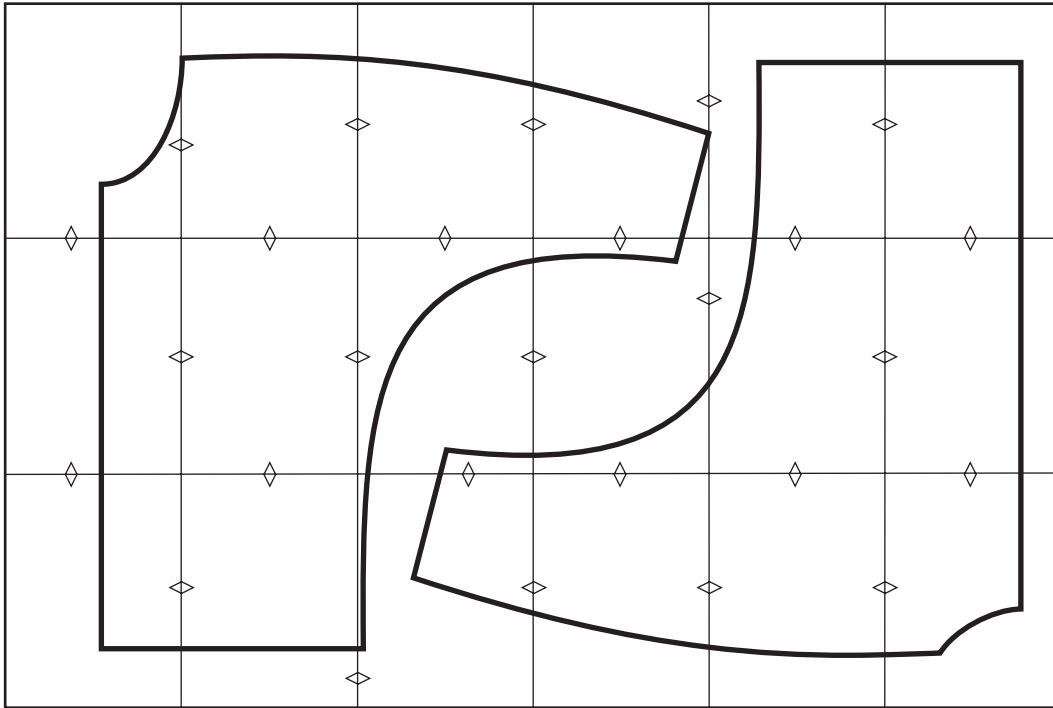

Size Key

XS-S
M-L	- - - - -
XL-XXL	- - - - -

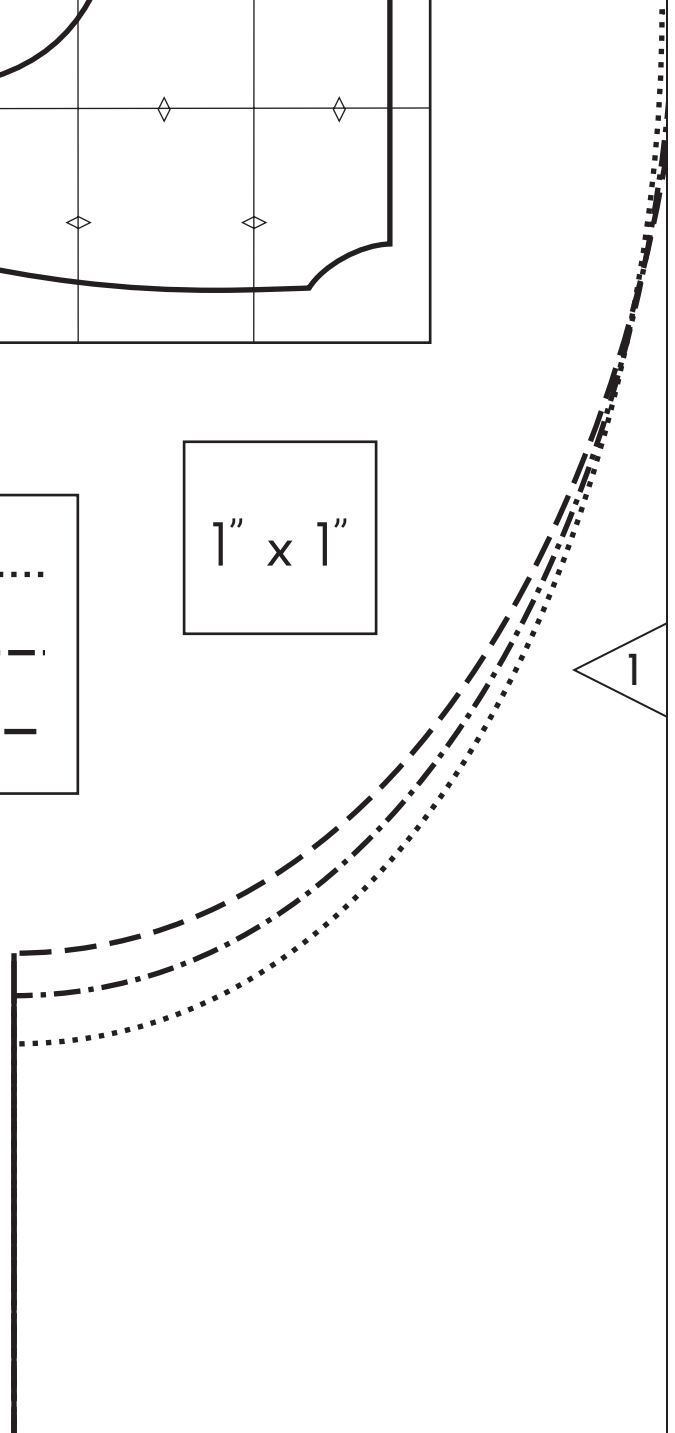
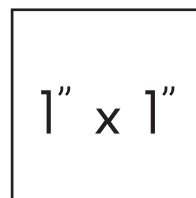

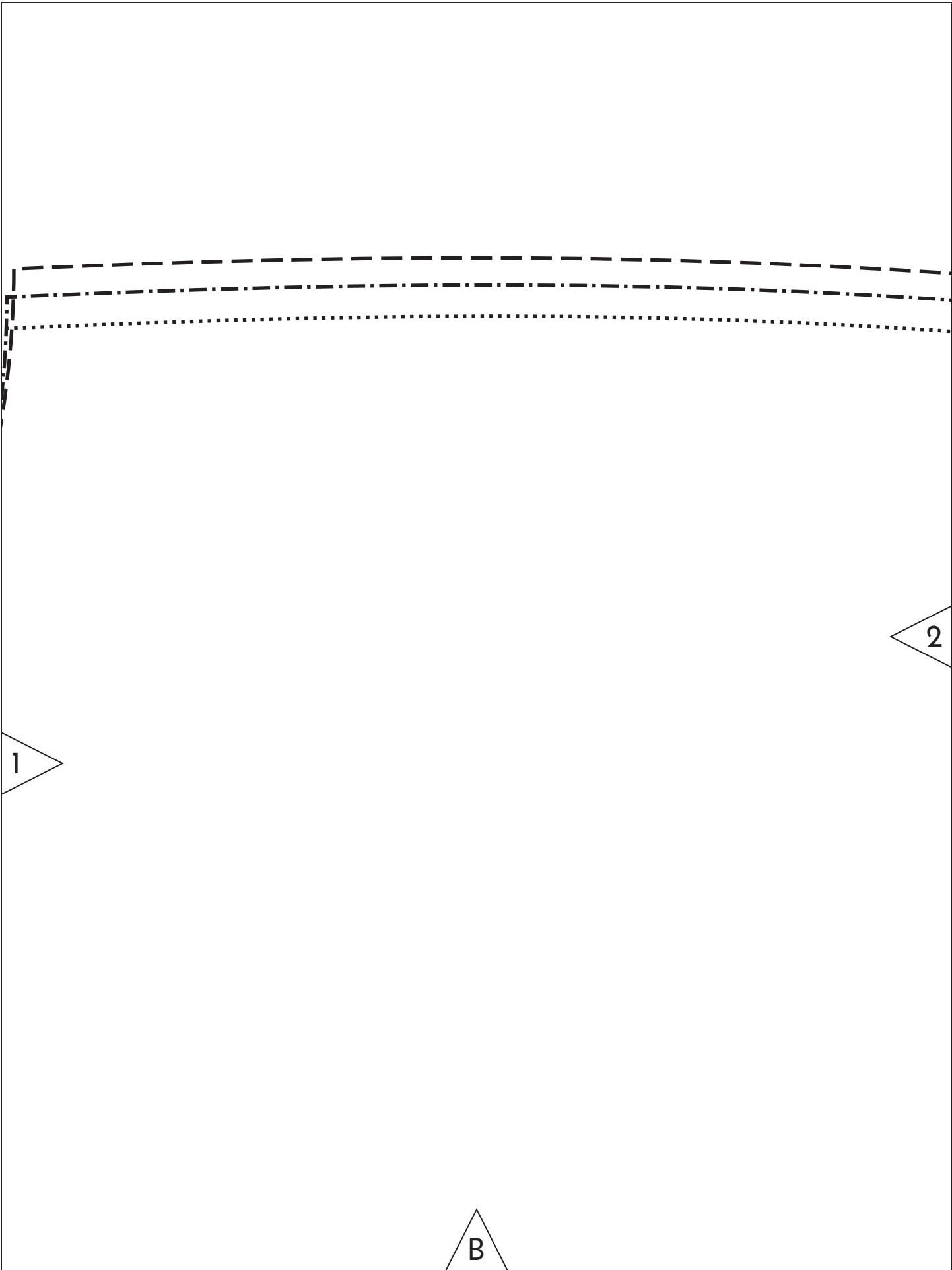

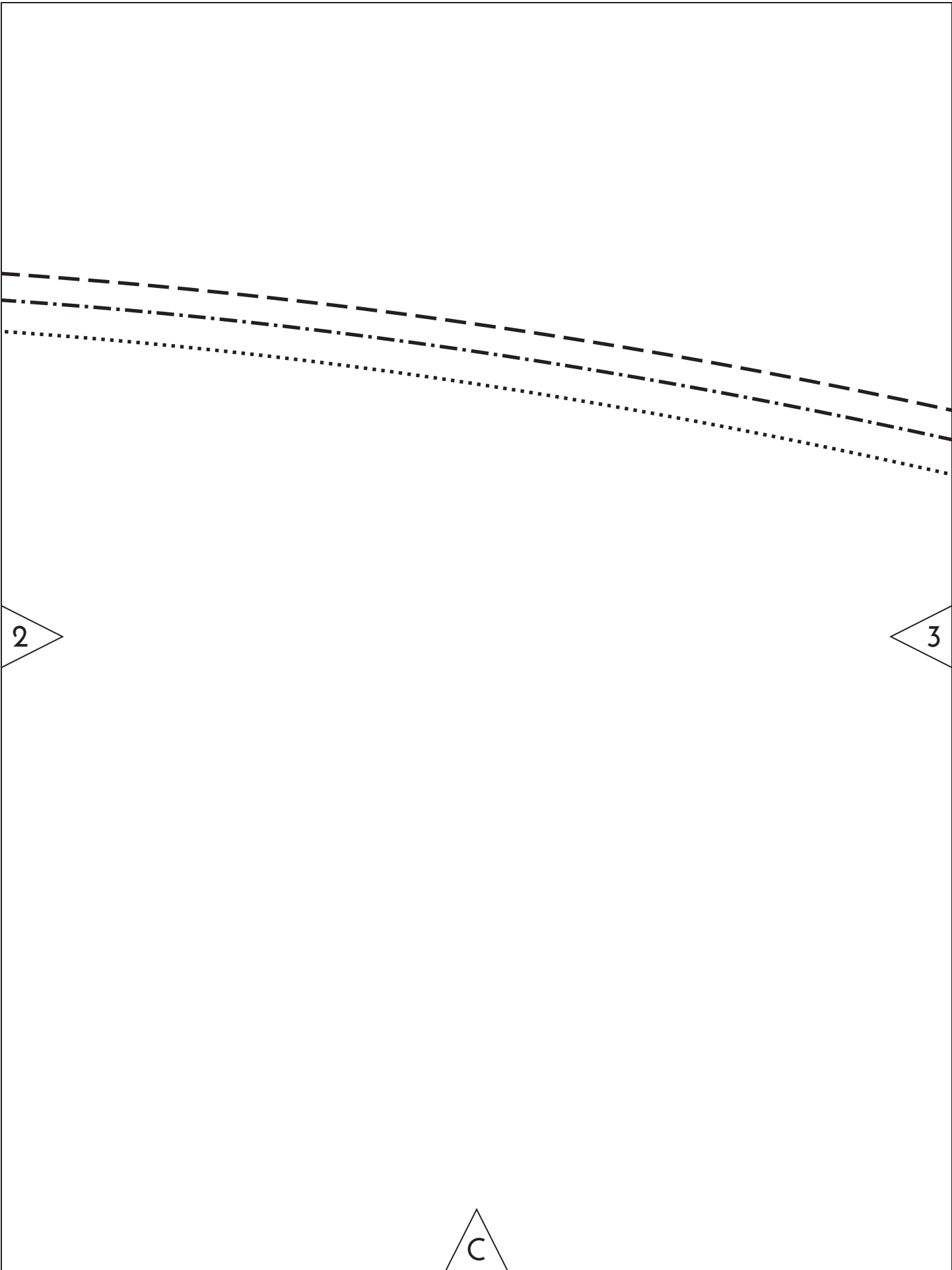

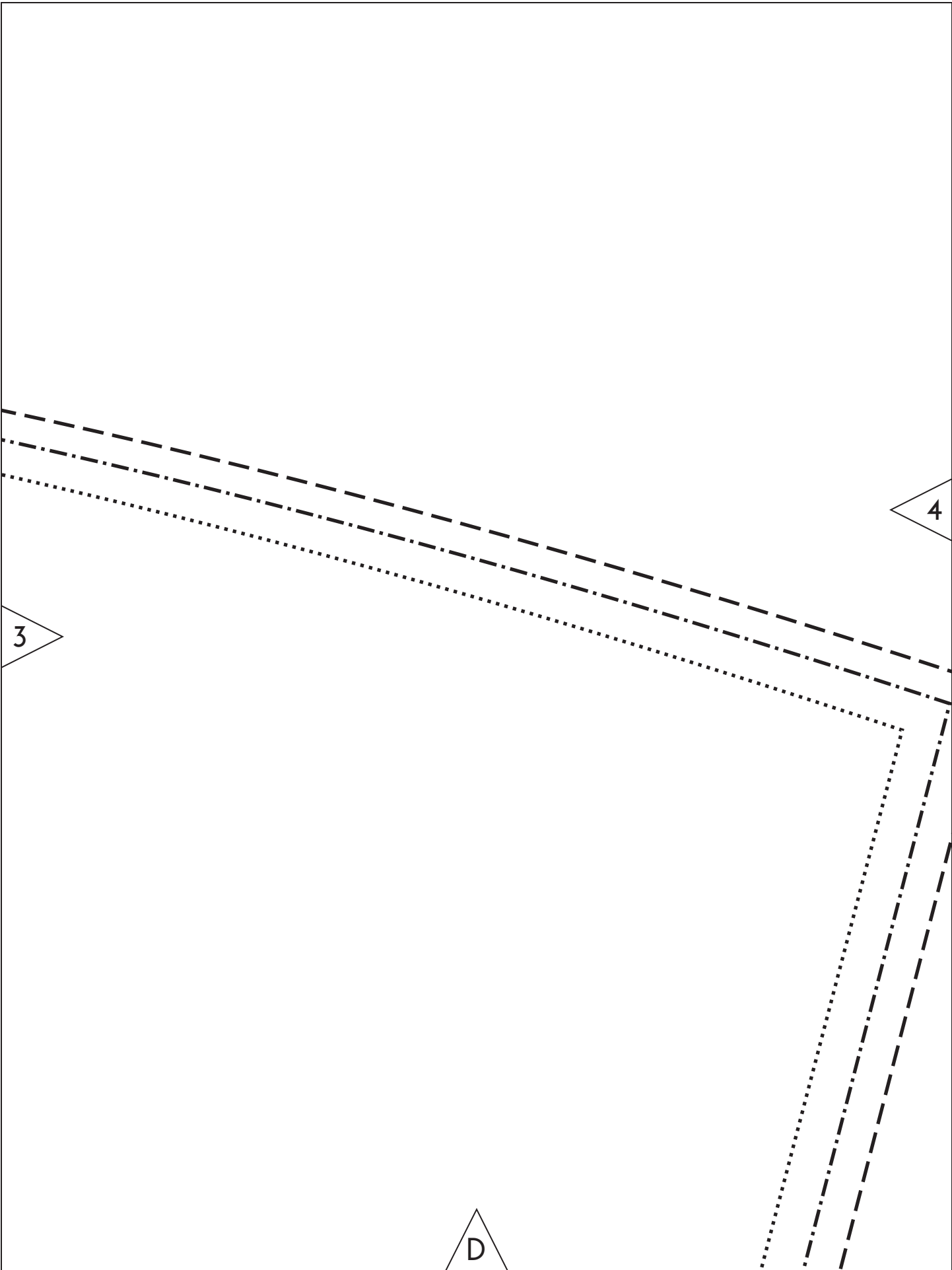

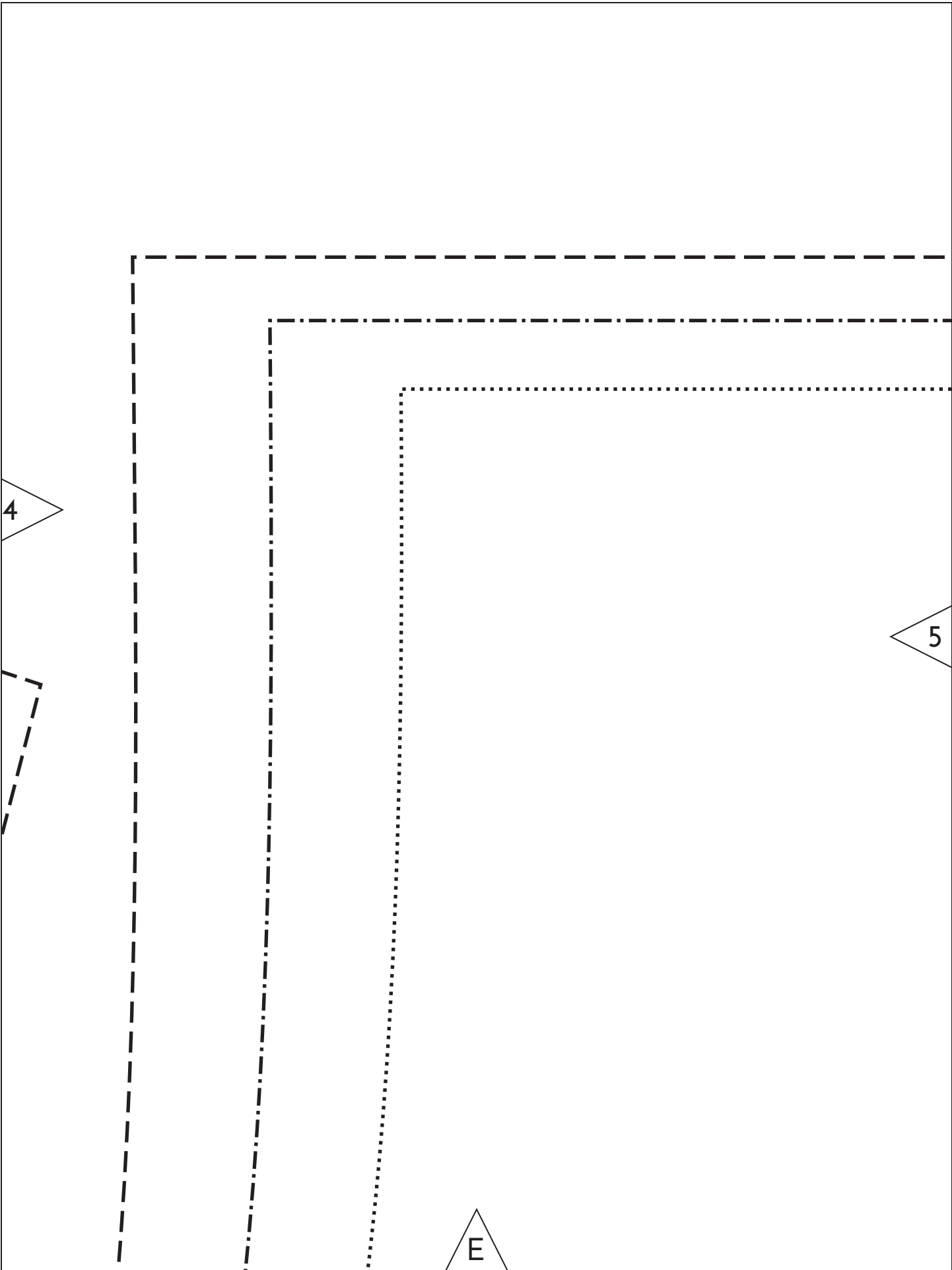

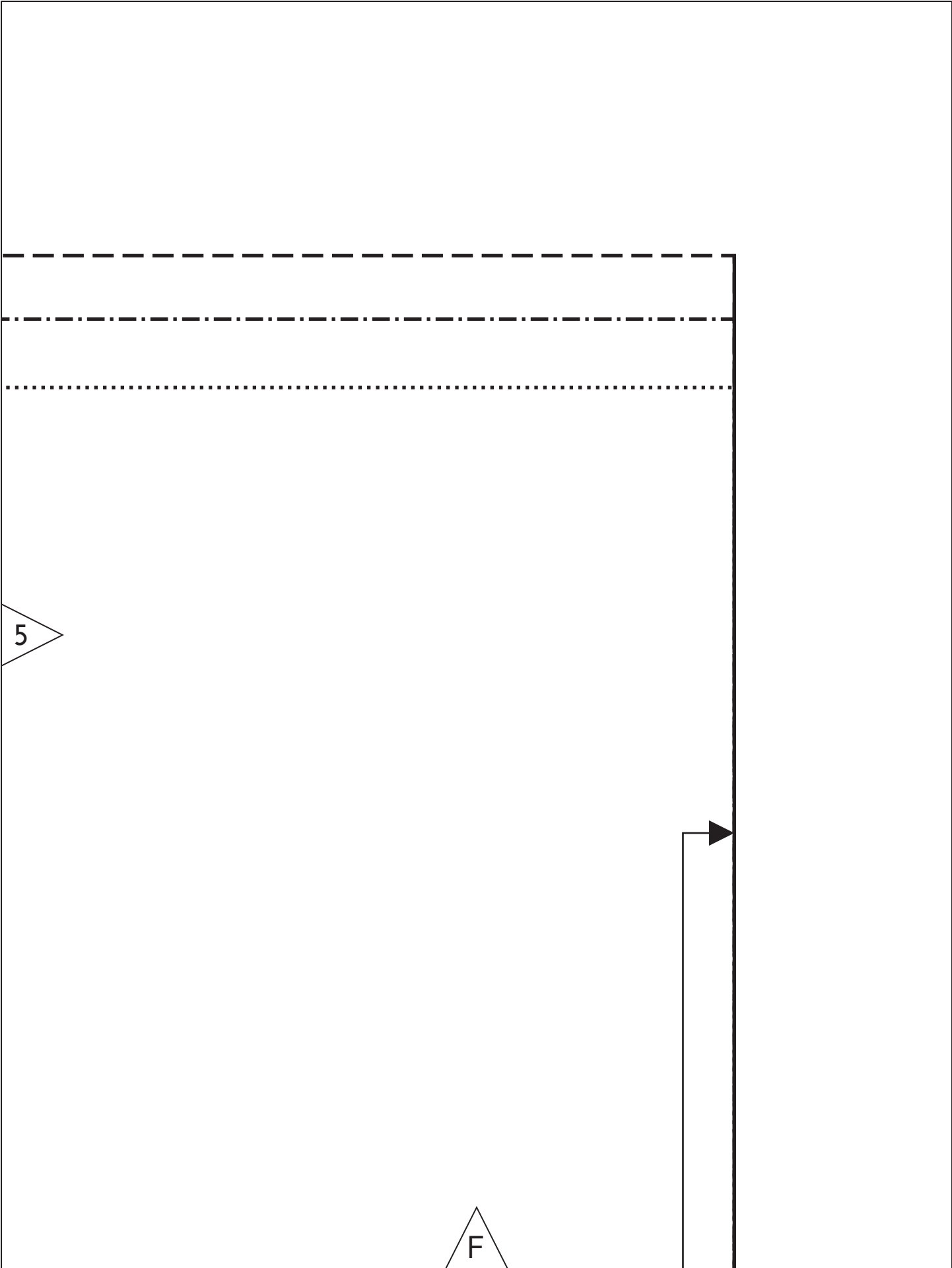



place on fold



B

One Hour Top

© Fancy Tiger Crafts 2014

FRONT

1

Cut 1 on fold

6

7

H



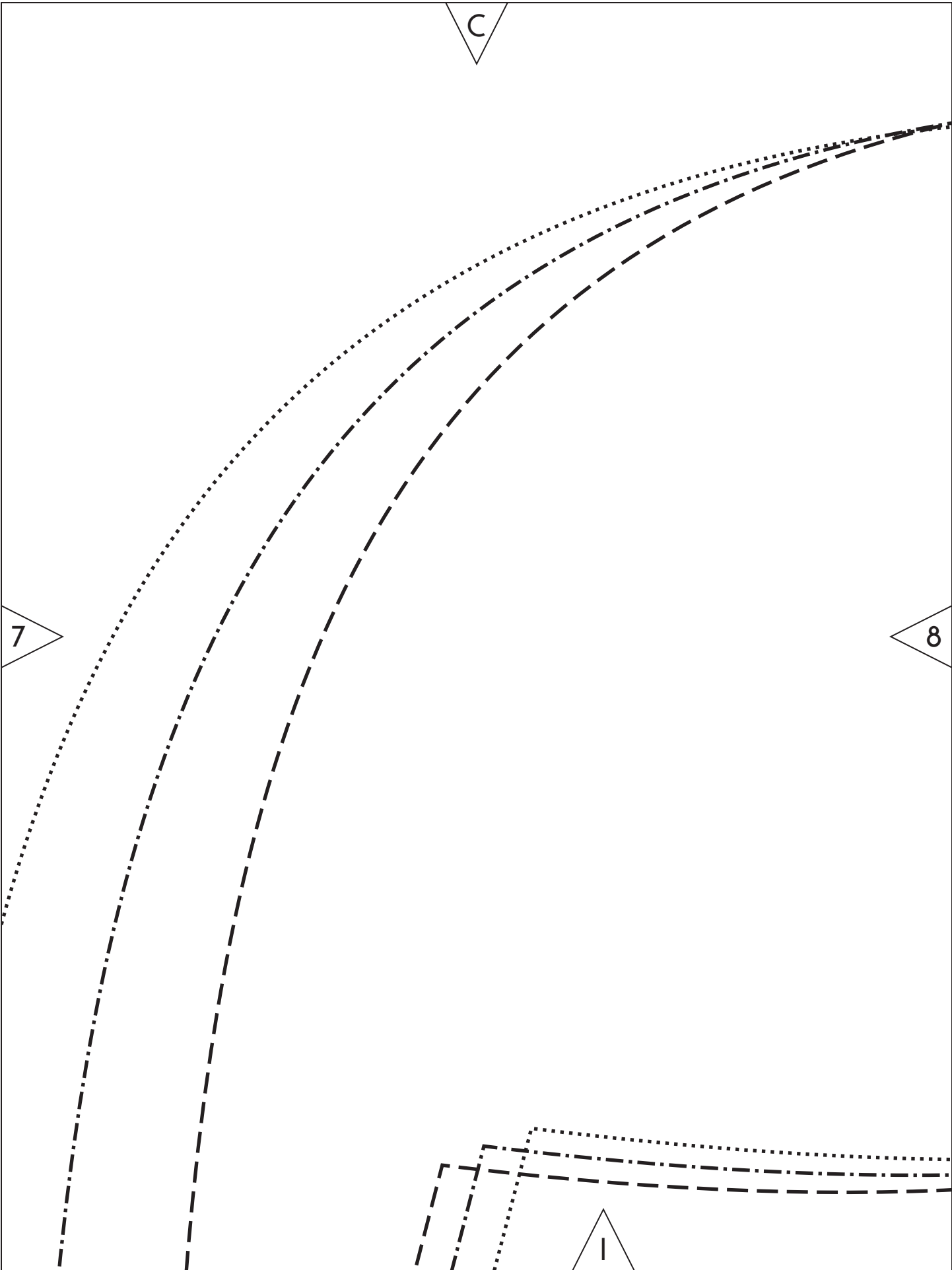

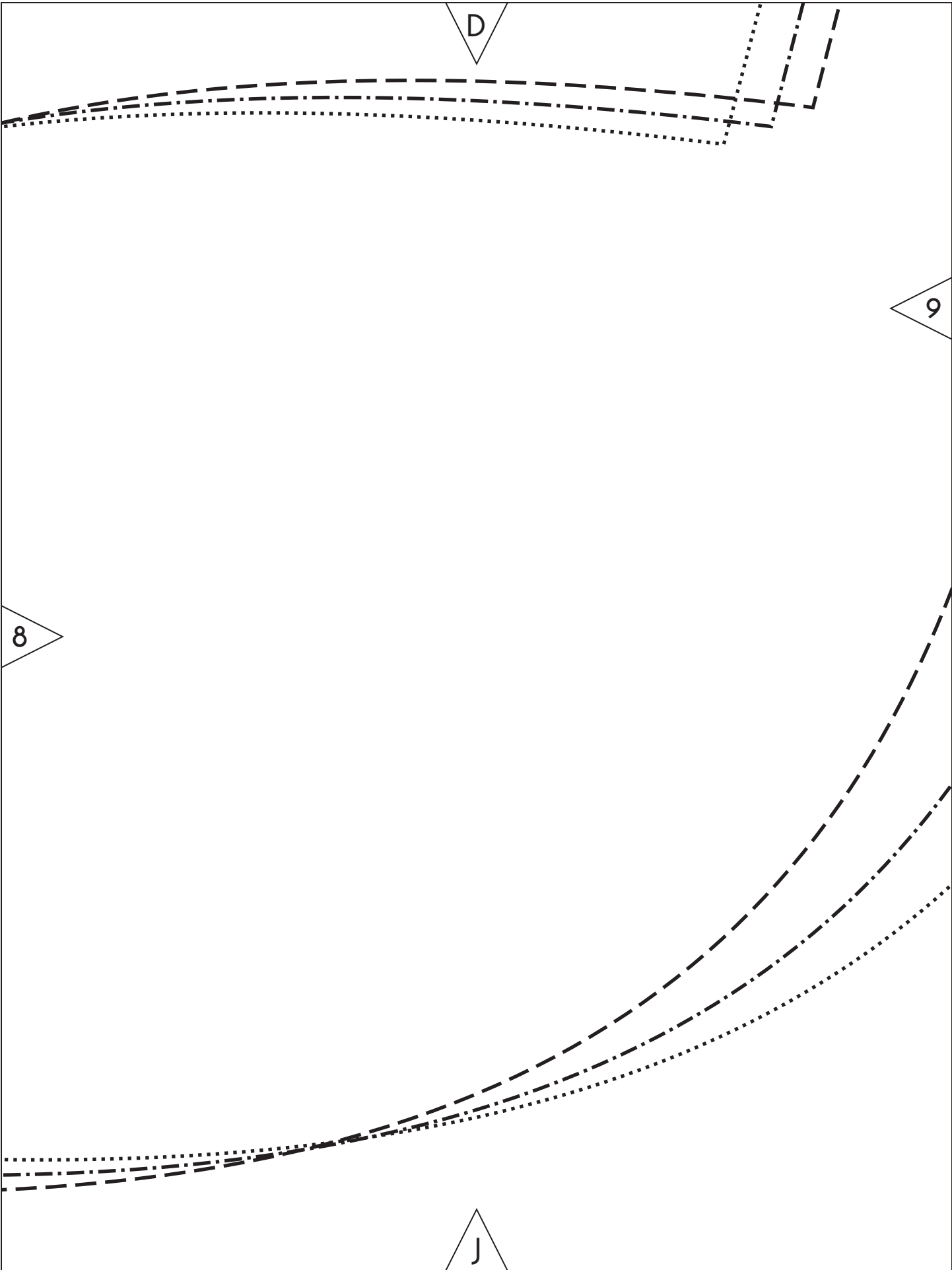

One Hour Top
Agency Tiger Crafts 2014

BACK

2

Cut 1 on fold

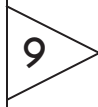
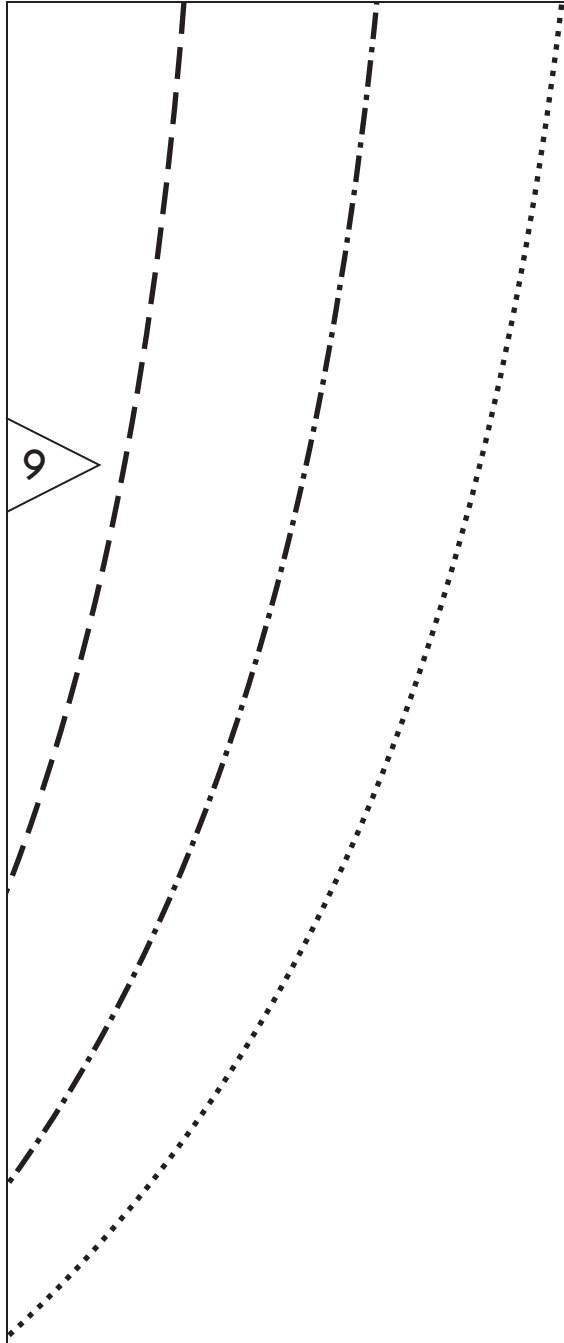
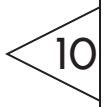

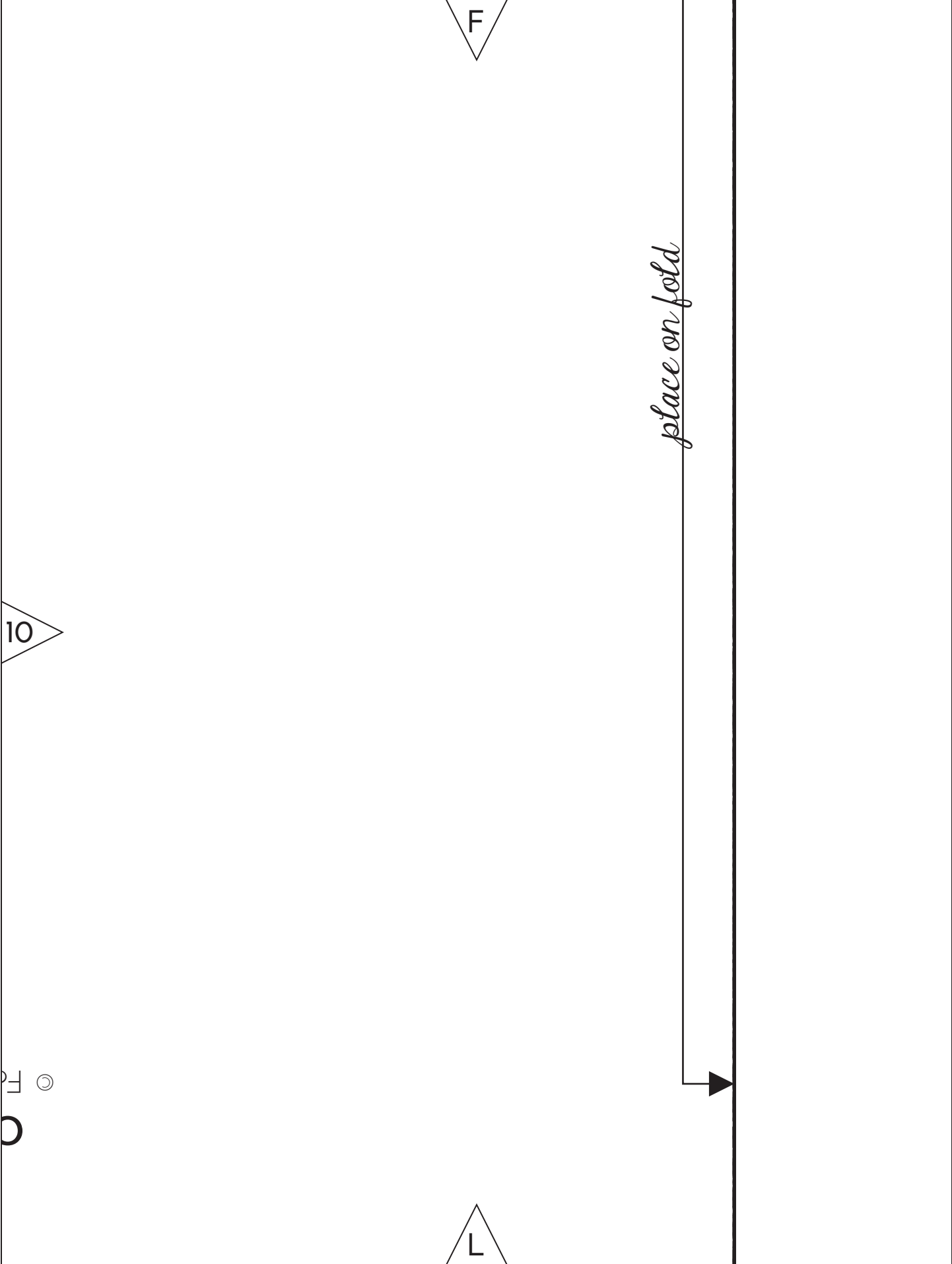

G



11



H

11

12

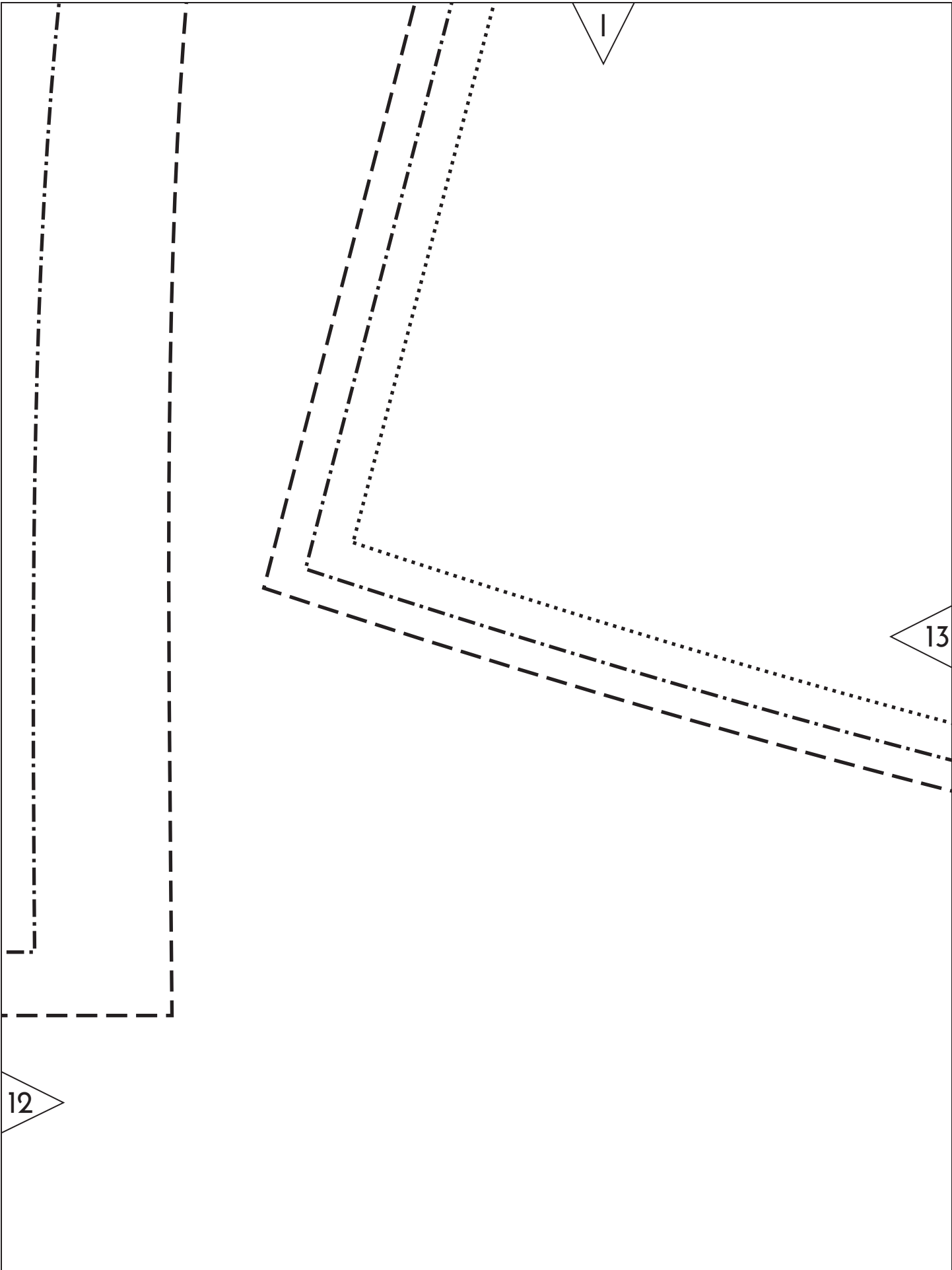

J

13

14

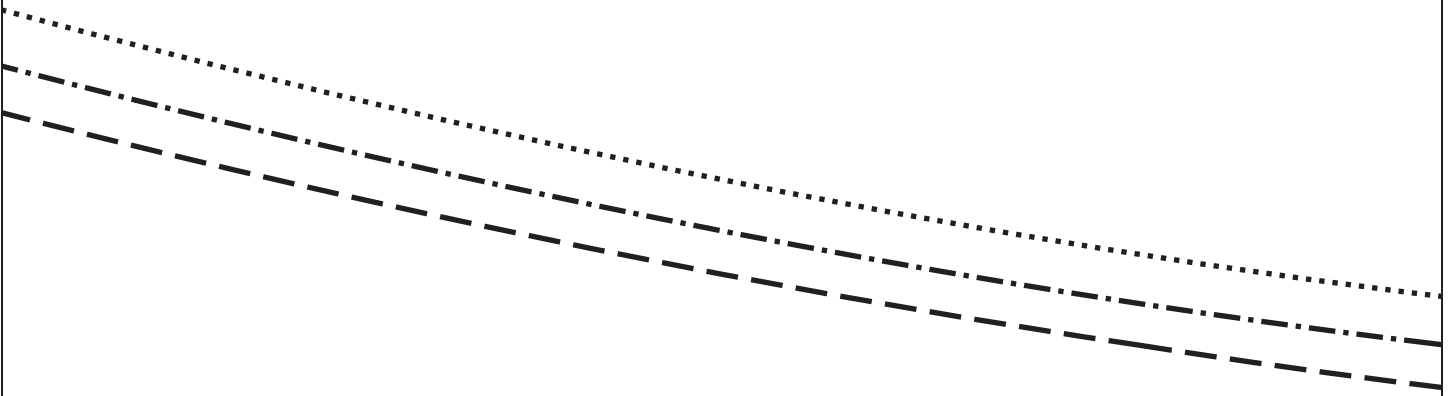

K

14

15

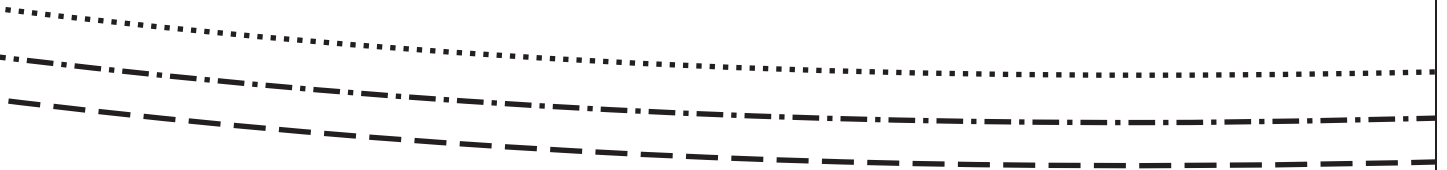

L

15

