

FANCY ✕ TIGER ✕ CRAFTS

ABBEY ROAD

KEELY SHAW and AMBER CORCORAN



WWW.FANCYTIGERCRAFTS.COM

Designed for Row by Row Experience 2018

This modern take on an iconic musical moment is a fun foundation paper pieced project that will come together almost as fast as a 3-minute pop song. If you're new to paper piecing or need a refresher, visit our technique video (link below) and get by with a little help from your friends here at Fancy Tiger.

WWW.FANCYTIGERCRAFTS.COM/PAPER-PIECING

#abbeyrowbyroad

ABBEY ROAD

MATERIALS

Fancy Tiger Abbey Road Kit

OR

1 fat eighth for the silhouettes

1 fat eighth for the crosswalk markings

5/8 yard for the background

TOOLS

Fabric glue stick

Basting spray

Coordinating thread

Foundation paper piecing paper
or newsprint (optional)

A sewing ruler with 1/4" markings

Rotary cutter & mat

Scissors



When You're Paper Piecing:

1. Fabric is sewn to the NON-PRINTED side of the paper. The PRINTED side of paper will face up as you are sewing.
2. When sewing, use a 1.5 stitch length and a larger needle than you'd normally use to piece a quilt. This will create more perforations and make it easier to remove the paper later.
3. Use an open-toe or clear foot so you can easily see the lines as you sew and make precise stitching on your lines.

Before you begin:

Cut each paper pattern block piece out around the outer-most line. This is a built-in 1/4" seam allowance that you will use when attaching each block together to make the completed row.

Pattern Notes:

1. Photocopy pattern pages onto foundation piecing paper (if you have the kit, this is already done for you). Foundation paper tears easily and will make removing the papers at the end much easier. Regular paper can be used, but use extreme care when removing papers, or you may tear your stitches out.
2. Each of your blocks has sections with a letter and a number. The letter indicates which pattern block you're working with, and the number indicates what order you should attach each piece of fabric to your pattern piece.
3. Blocks A1 and B1 are both the background fabric.
4. Keep in mind as you sew, the paper side of your project will be the mirror image of the finished row.

ABBEY ROAD

Start by assembling Block A as follows:

ROUGH CUT YOUR A1 BACKGROUND PIECE:

With printed side of pattern paper facing up, place your background fabric right side DOWN, covering section A1 and overlapping the edge by at least 1/4" for your seam allowance.

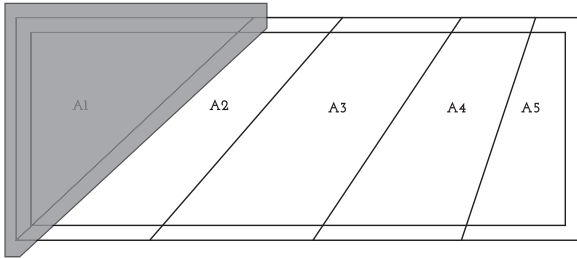

Note: This doesn't have to be a perfect seam allowance, as you can trim after you sew. Erring with a little extra seam allowance will make it easier to have a successful block.

Use a small dab of fabric glue to baste the wrong side of the A1 fabric with the NON-PRINTED side of paper pattern, centering it under the A1 section.

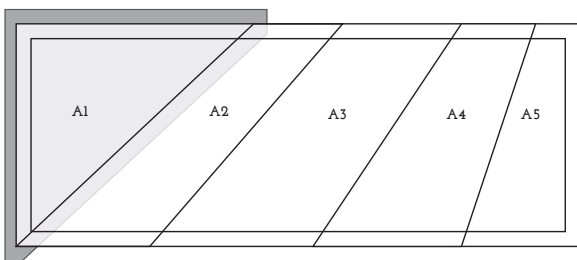

ROUGH CUT YOUR A2 CROSSWALK MARKING PIECE:

With printed side of paper facing up, place your crosswalk marking fabric right side DOWN covering section A2 and overlapping the edges by at least 1/4". Cut out your crosswalk marking piece with at least 1/4" seam allowance.

Note: Make sure as you cut your 2-5 pieces, you are placing the right side of the fabric toward the printed side of the paper.

PAPER PIECING:

If you need additional guidance on Foundation Paper piecing, check out our instructions at: www.fancytigercrafts.com/paper-piecing

Important Note:

You will be attaching fabric to the non-printed side of your pattern piece.

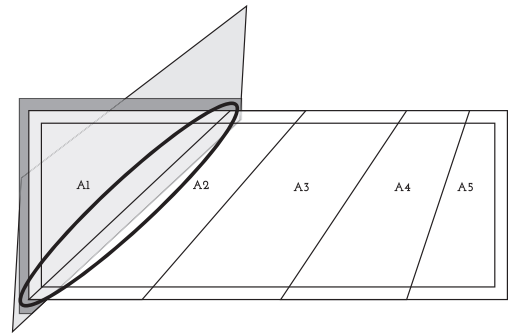

Place the A2 crosswalk-marking fabric under the paper so it is centered below the printed A2 paper section, wrong side facing the non-printed side of paper. Carefully flip A2 along the seam line toward section A1. A1 and A2 should now be right sides together. Hold it in place, clip or pin the layers and sew along the A1/A2 seam line with paper facing up.

Carefully trim your seam allowance to 1/4"

Fold A2 back toward the A2 paper section and press flat.

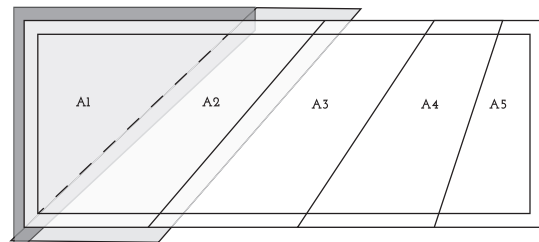

Repeat in this manner working through all sections in numerical order until all pieces are attached are attached for blocks A and B.

Note on mistakes: If you happen to make a mistake and the fabric doesn't cover your section when you fold it at the seam, you can use a strip of Scotch tape on the paper before you use the seam ripper on the fabric side. That will help your paper stay together when you sew it again.

ASSEMBLE CROSSWALK:

1. Use a ruler and rotary cutter to trim excess fabric from your pieced blocks, going all around the paper leaving the seam allowances intact.
2. Put right sides together and sew along the seam allowance line between A5 and B1. Press the seam open.

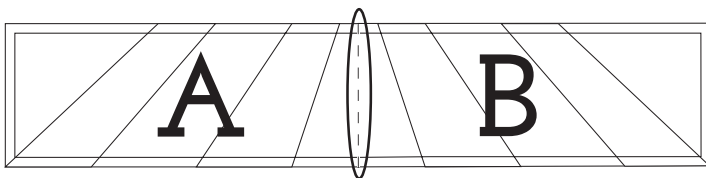

CUT YOUR BACKGROUND PIECES:

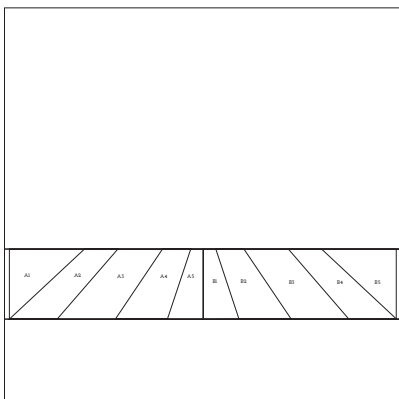

1. Cut a piece of background fabric 18.5" x 3.75" (hint: you can use your crosswalk piece as a perfectly sized template!)
2. Cut a piece of background fabric 18.5" x 12".

ASSEMBLE BLOCK:

1. Attach your shorter piece of background fabric to the bottom of the crosswalk, sewing along the 1/4" seam allowance line of your crosswalk piece.
2. Attach your larger background piece to the top of the crosswalk, sewing along the 1/4" seam allowance at the top of your crosswalk piece.
3. Carefully remove your papers and press.

ATTACHING THE SILHOUETTES:

When the silhouettes are printed on foundation paper piecing paper, it's easier to work with them, as they're easier to cut.

1. Rough cut each silhouette from the paper piecing paper (you'll cut around the lines when it's attached to the fabric). Use pins or a small dab or two of disappearing fabric glue to attach each pattern piece to the RIGHT SIDE of the fabric.
2. Cut around each piece and remove the paper pattern pieces.
3. Lay the cut fabric silhouettes wrong side up (walking left!) on a flat surface like waste cardboard or paper (you'll recycle this after, so don't use something you want to keep!). Carefully spray them with basting spray.
4. Arrange the silhouettes on your completed block. The basting spray will allow you to reposition once or twice max, and each time you pull them up you risk the edges fraying. We recommend using the placement of their feet in relation to the crosswalk to get correct positioning.
5. Attach the silhouettes using your favorite applique method - on the machine, you can use blanket stitch or a very thin satin stitch. You can also use blanket stitch by hand. We don't recommend applique where the edges fold under, as you will lose much of the detail.

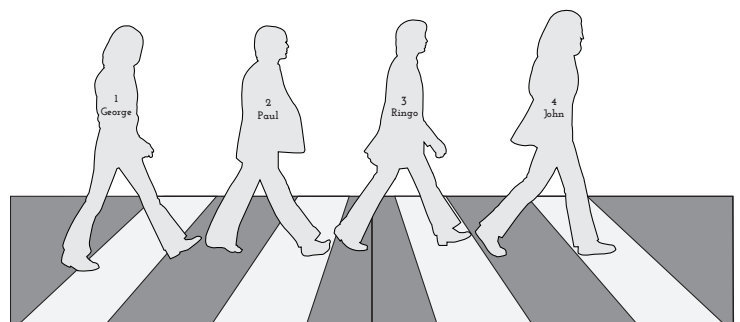

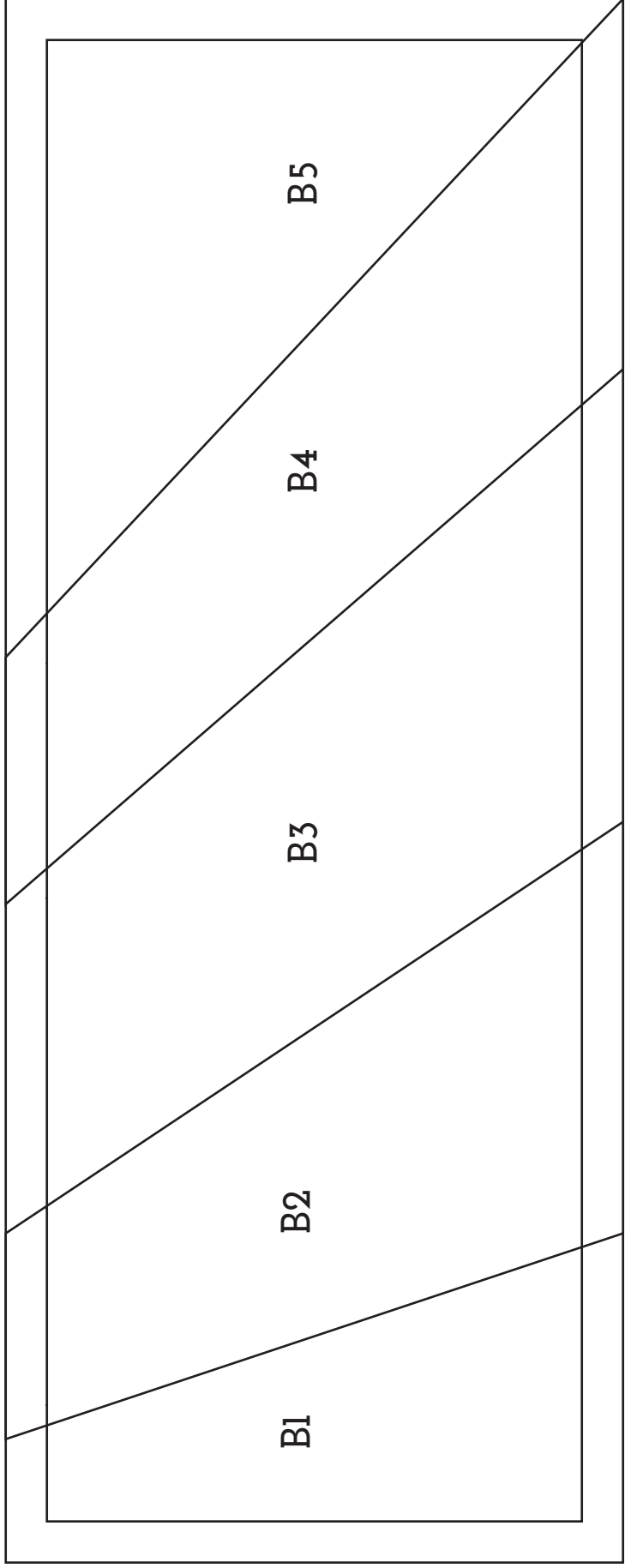
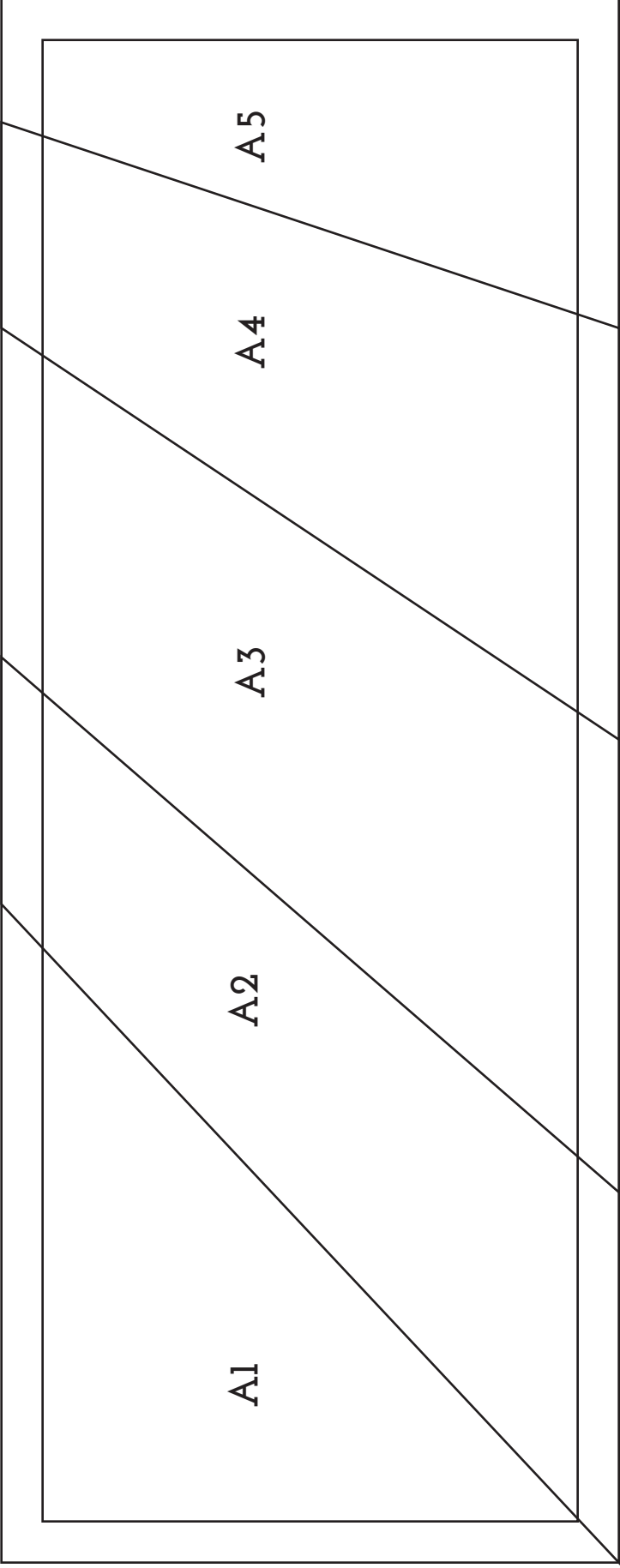

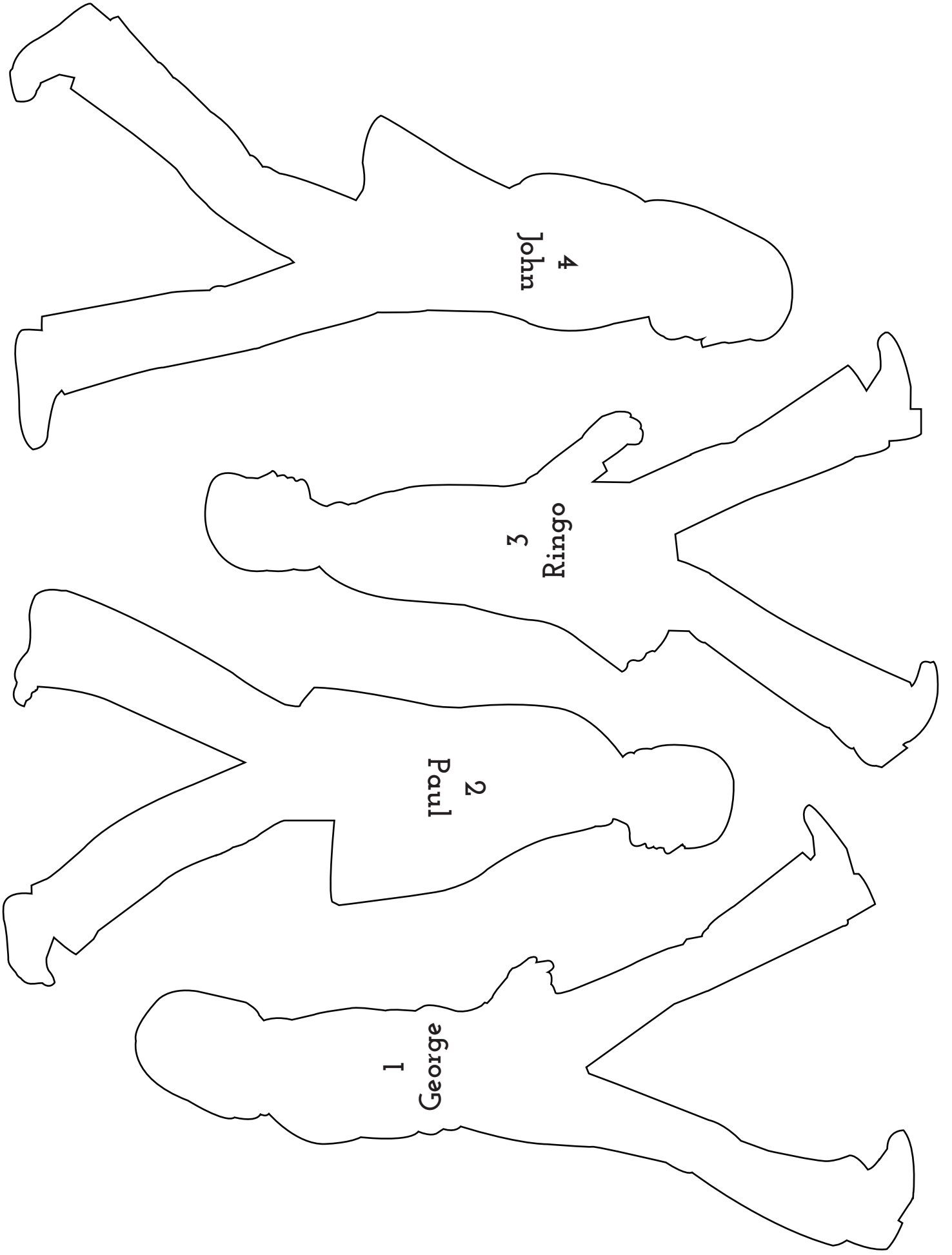

1
George

2
Paul

3
Ringo

4
John