

This manual is intended primarily for use by professional bicycle mechanics. Users who are not professionally trained for bicycle assembly should not attempt to install the components

If any part of the information on the manual is unclear to you, do not proceed with the installation. Instead, contact your dealer or a local bicycle shop for their assistance.

Make sure to read all instruction manuals included with the product.

You can find all the manuals and specs on our website <http://ingrid.bike>

# INGRID



Rev. 1.0 2021/07

## MAINTENANCE

This product is not guaranteed against natural wear and deterioration from normal use and aging.

**!!! PERIODICALLY CHECK THE TIGHTENING. INCORRECT TIGHTENING CAN CAUSE MALFUNCTIONS OR BREAKAGE**

MOSCONI s.r.l. | via la Villa 28 zona artigianale Ghilardino 61034 Fossombrone, PU

## BOTTOM BRACKET SPECIFICATION

**OUR CRANKSET SYSTEM IS DESIGNED WITH AN ASIMMETRY OF +2.5MM ON DRIVE SIDE**

The common MTB frames/BB cups are asymmetrical and that provides the necessary configuration (fig.1)

The common ROAD frames/BB cups are symmetrical. In this case add 2.5 mm on the drive side (fig.2)

VERIFY THAT THE FRAME/BB CUPS COMPLIES WITH THE REQUIRED DIMENSIONS FOR OUR SPINDLES

### MTB

fig.1

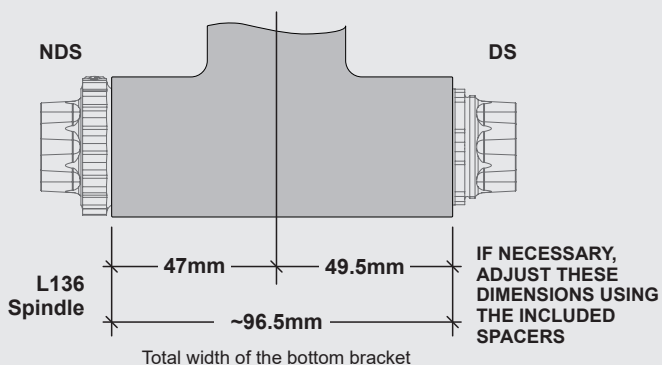

### ROAD

fig.2

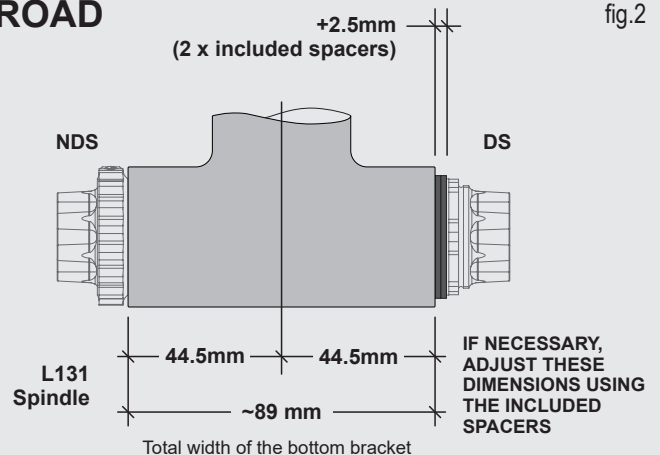

Hand screw the RING to preload the crankset until it stops. Make sure there is no play. Tighten the screw to lock the preload ring by a T9 Torx screwdriver.

USE THE INCLUDED SPACERS AS INDICATE IN THE PREVIOUS PAGE BB SPECIFICATION

DO NOT USE WAVE WASHERS

~11.5 mm

AFTER INSTALLATION CHECK THIS DIMENSION NDS

APPLY HIGH QUALITY LITIO+PTFE GREASE TO RED COLORED SURFACE

CHAINRING LOCKRING TOOL ING-T-CS

TIGHTENING TORQUE 15 Nm

APPLY A MEDIUM-STRENGTH THREADLOCKER ON THE LOCKRING THREAD

10

10MM ALLEN KEY

TIGHTENING TORQUE 40-45 Nm

BE SURE TO ALIGN THE LEFT ARM WITH THE CHAINRING LOGO

APPLY HIGH QUALITY LITIO+PTFE GREASE TO RED COLORED SURFACE

10

10MM ALLEN KEY

TIGHTENING TORQUE 40-45 Nm

APPLY HIGH QUALITY LITIO+PTFE GREASE TO RED COLORED SURFACE

CRANCKSET DISASSEMBLY

!!! DO NOT REMOVE THE RING NUT

To remove the cranks use only a 10mm allen key. Before unscrewing CLEAN and LUBRICATE the space between the screw and the self-extractor ring

10

10MM ALLEN KEY

SELF-EXTRACTOR RING and SCREW REPLACE

APPLY HIGH QUALITY LITIO+PTFE GREASE TO RED COLORED SURFACE

APPLY A HIGH-STRENGTH THREADLOCKER ON THE SELF-EXTRACTOR RING THREAD

SHIMANO CASSETTE LOCKRING TOOL

TIGHTENING TORQUE CLOCKWISE HAND TIGHT