

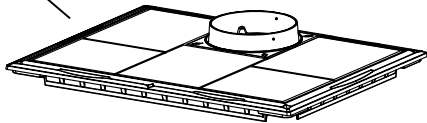

# Equinox Model 8000

## Illustrated Parts List

TOP: ASSEMBLY A



SECONDARY AIR:  
ASSEMBLY B

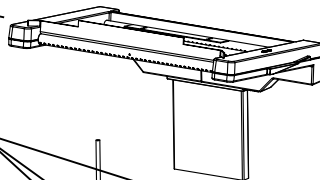

SIDE DOOR: ASSEMBLY E

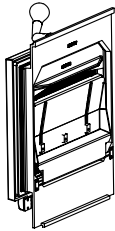

REAR EXIT: ASSEMBLY C

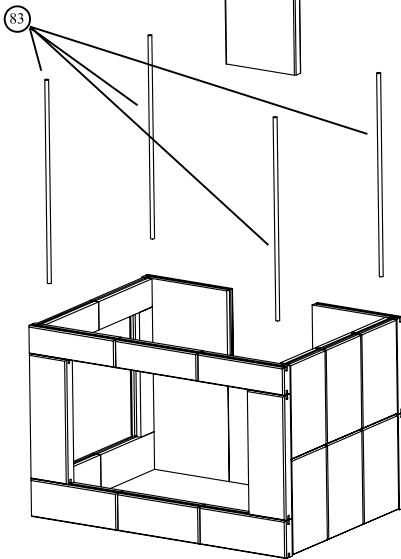

VERTICAL BODY:  
ASSEMBLY D

FRONT DOOR: ASSEMBLY F

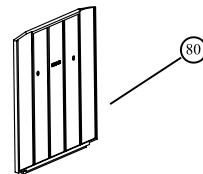
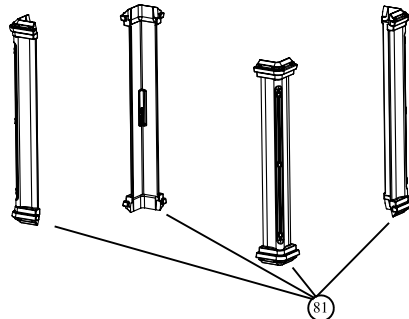
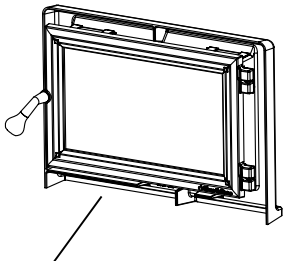

BOTTOM: ASSEMBLY G

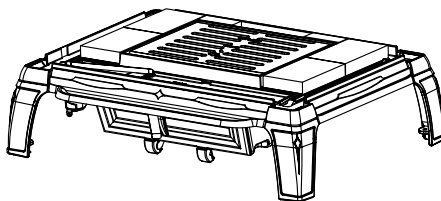

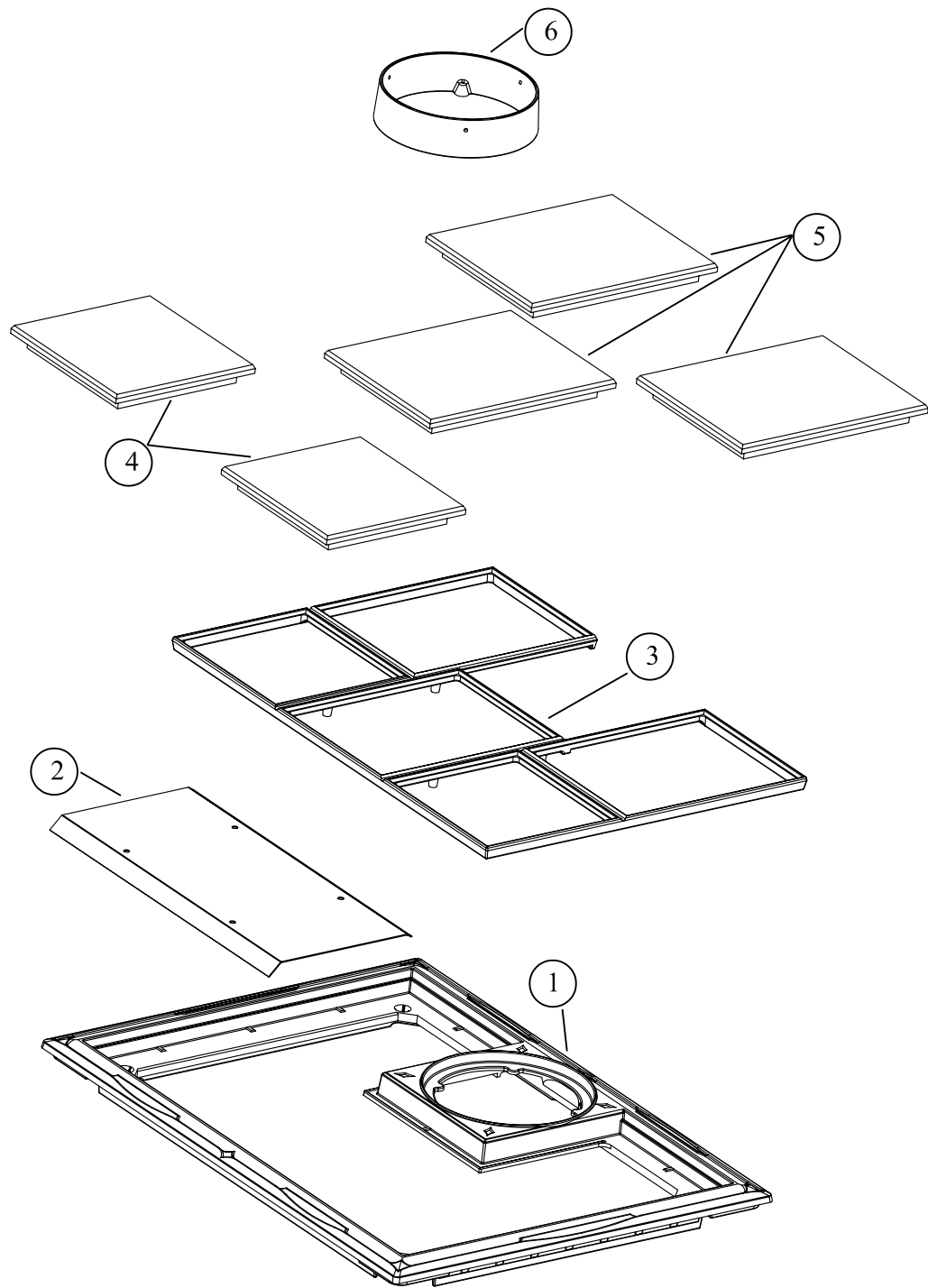

TOP: ASSEMBLY A

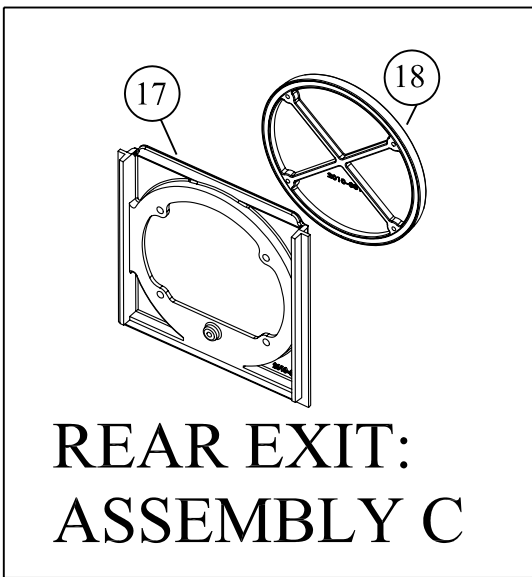
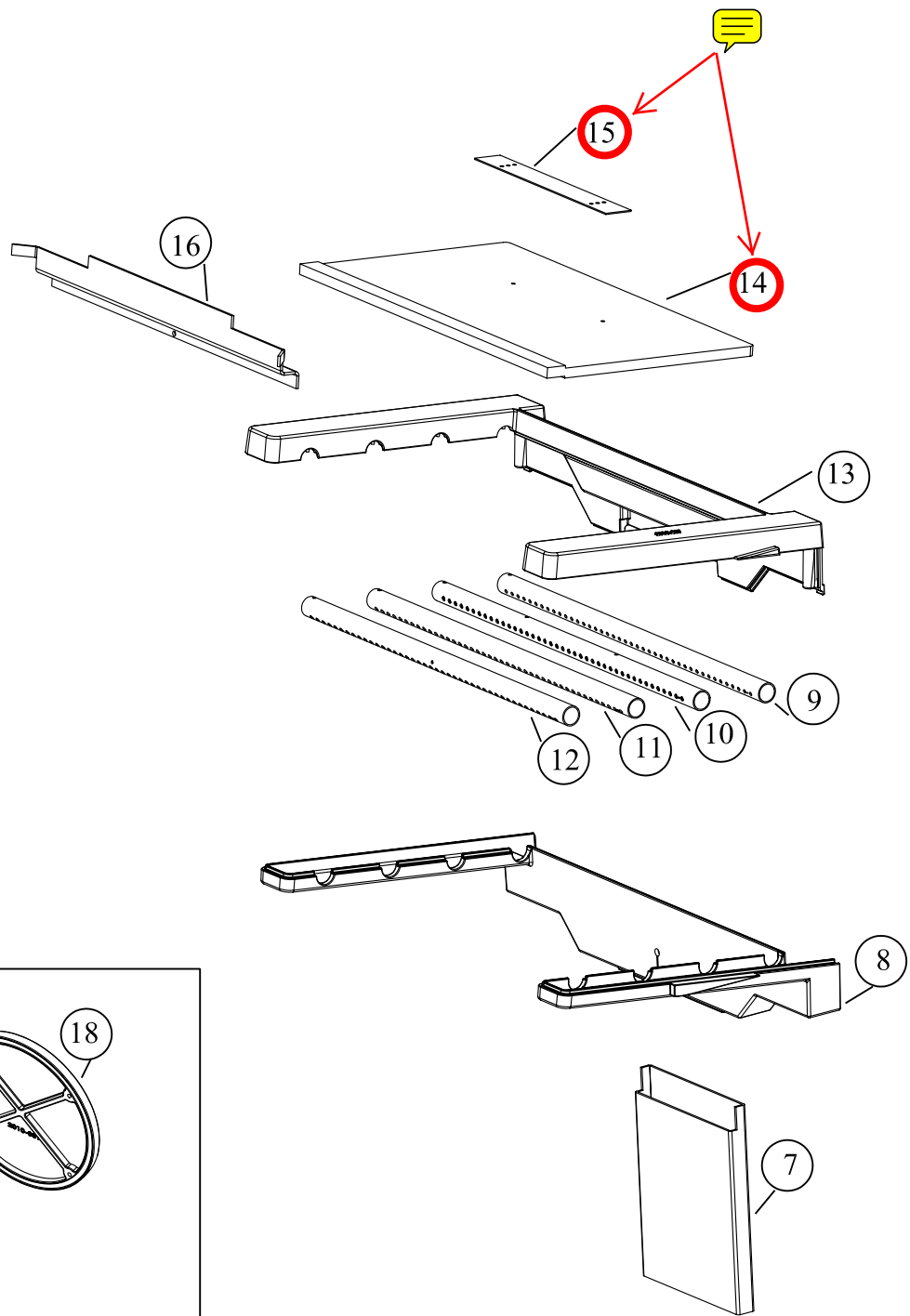

**REAR EXIT:  
ASSEMBLY C**

**SECONDARY AIR:  
ASSEMBLY B**

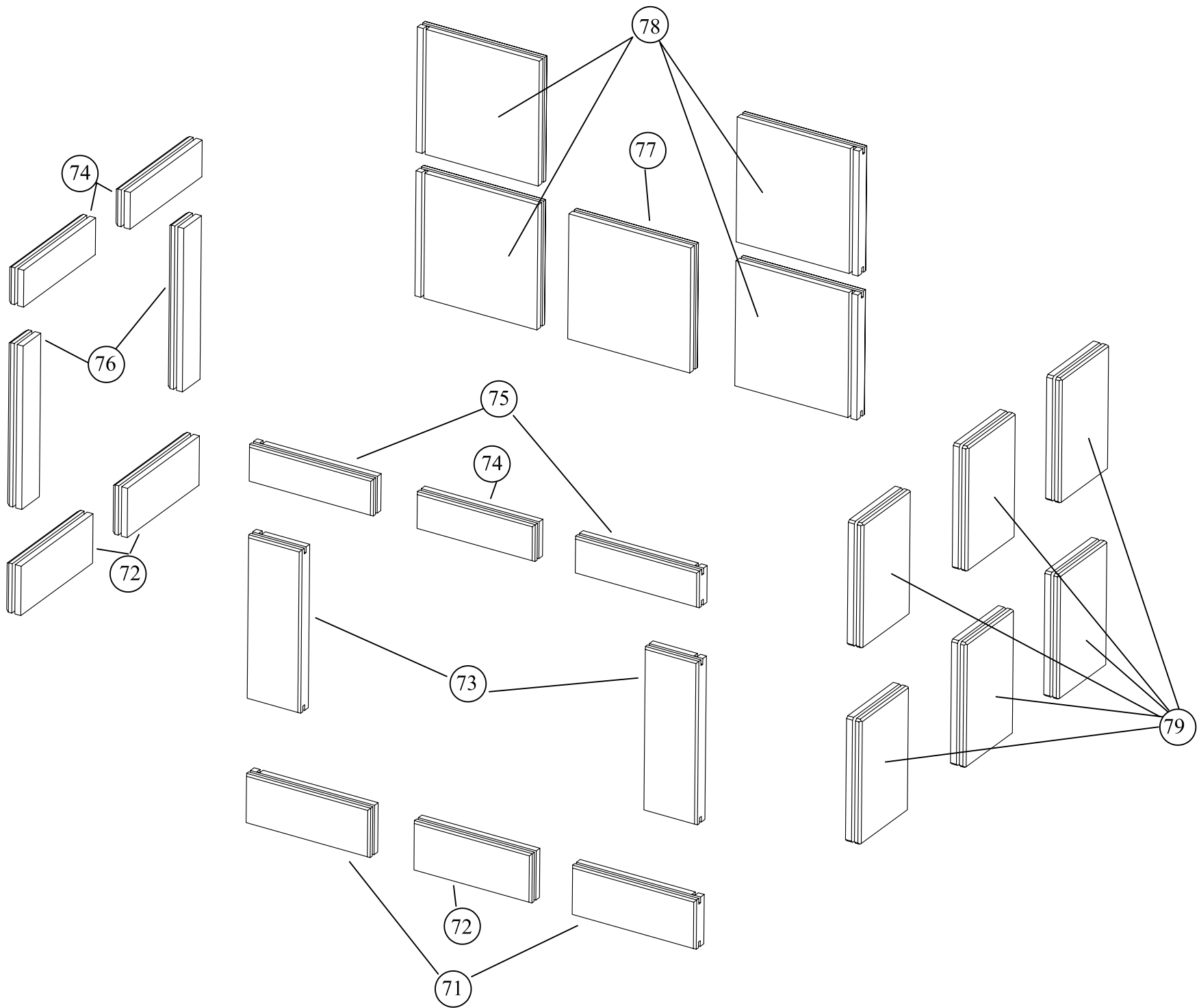

**VERTICAL STONE: ASSEMBLY D**

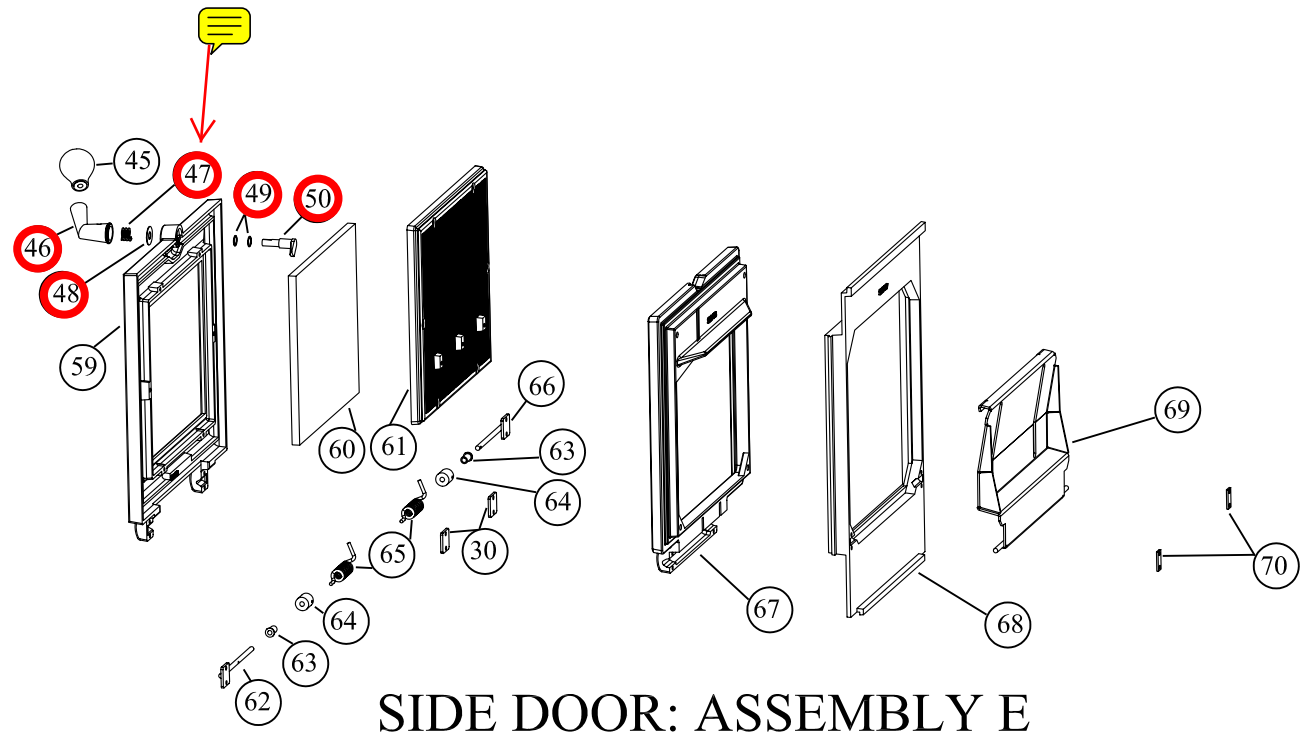

SIDE DOOR: ASSEMBLY E

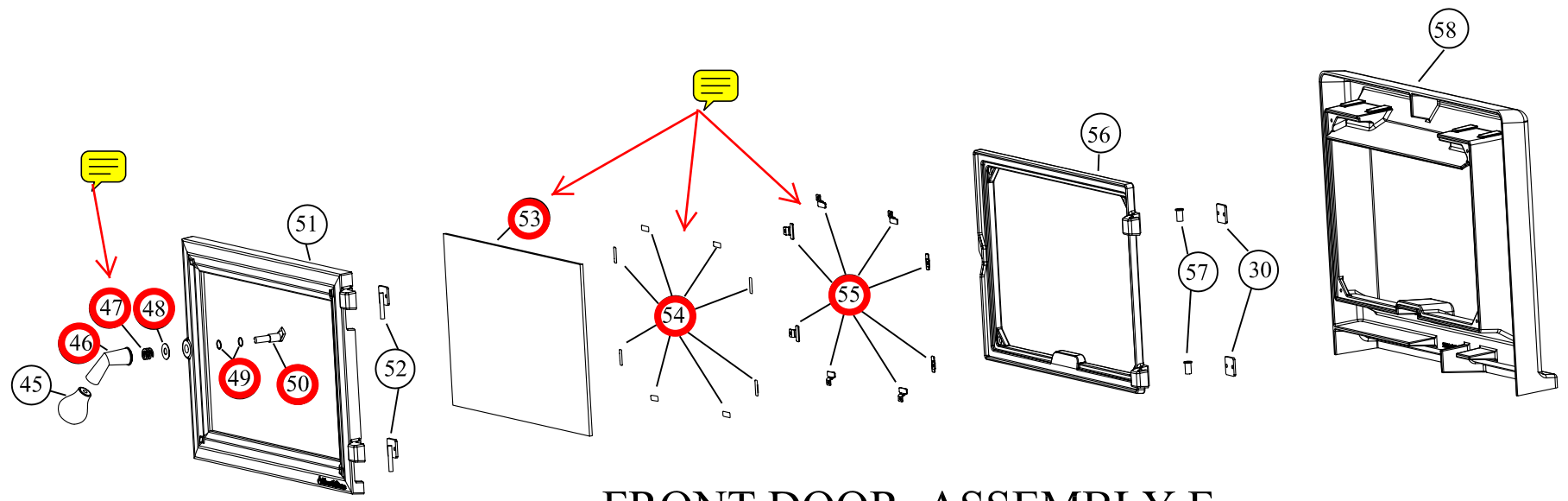

FRONT DOOR: ASSEMBLY F

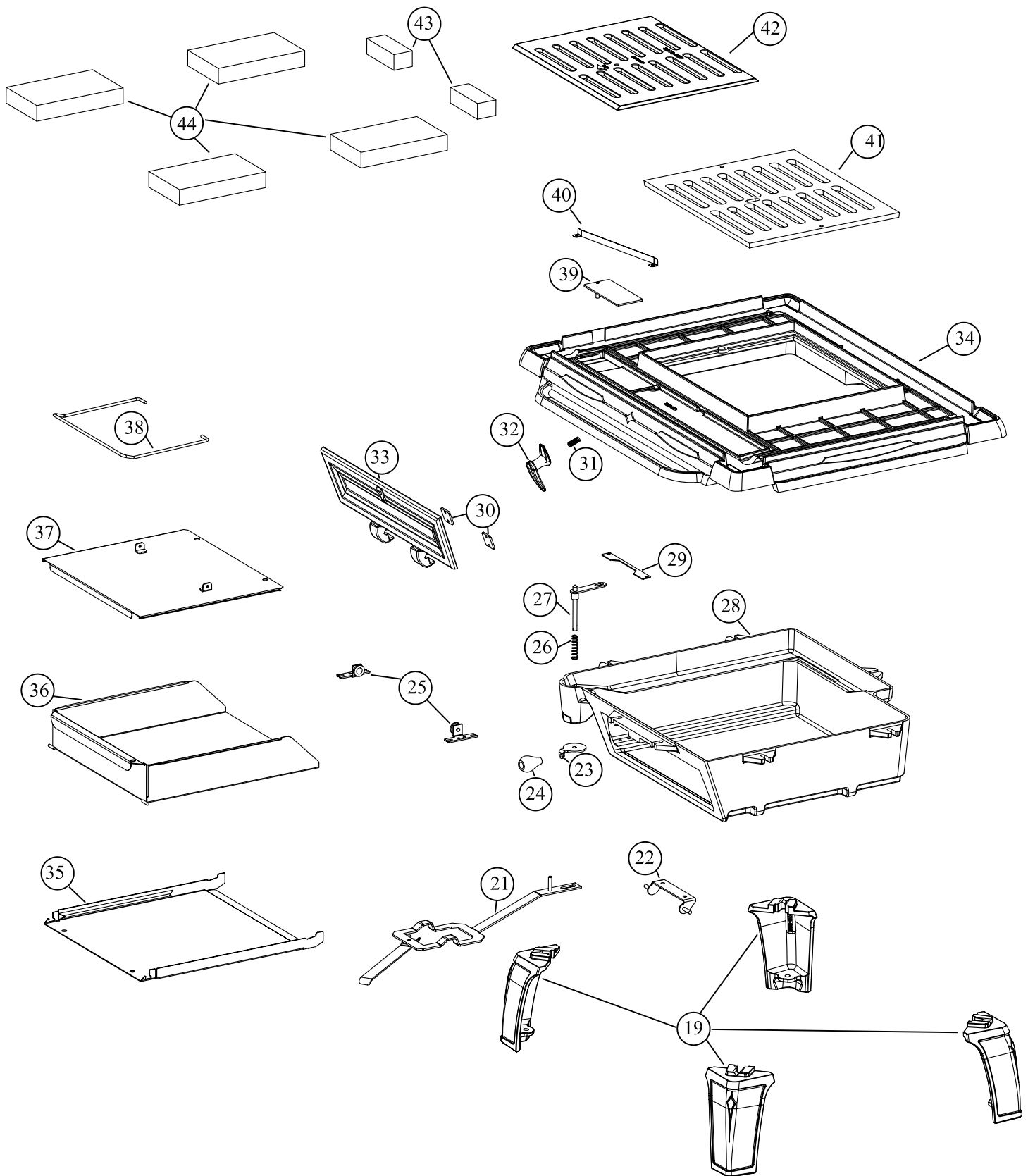

BOTTOM: ASSEMBLY G

Assembly	KEY	Component	Object description	QTY
A	1	2010-095	TOP: MATTE,EQU	1
A	2	5000-402	HEATSHIELD: TOP, EQU	1
A	3	2010-090	SUPPORT: TOP STONE,EQU	1
A	4	1041-060	STONE: POL,T,9.62"x8.99"x1.18"EQU	2
A	5	1041-070	STONE: POL,T(LG),12.03x9.62x1.18"EQU	3
A	6	2010-082	COLLAR: FLUE EXIT,EQU	1
B	7	5000-301	PIPE: AIR, SECONDARY RISER, EQU	1
B	8	2010-085	PLENUM: AIR,SECONDARY,BOTTOM,EQU	1
B	9	5000-581	AIR TUBE 1: SECONDARY, EQU	1
B	10	5000-582	AIR TUBE 2: SECONDARY, EQU	1
B	11	5000-583	AIR TUBE 3: SECONDARY, EQU	1
B	12	5000-584	AIR TUBE 4: SECONDARY, EQU	1
B	13	2010-087	PLENUM: AIR,SECONDARY,TOP,EQU	1
B	14	3120-001	BOARD: CERAMIC,BAFFLE,EQU	1
B	15	5021-066	BRACKET: BAFFLE,SS,HER 1	1
B	16	5000-401	SUPPORT: BAFFLE, EQU	1
C	17	2010-080	FRAME: FLUE,MATTE,EQU	1
C	18	2010-081	PLATE: FLUE,EQU	1
G	19	2010-005	FOOT: MATTE,EQU	4
G	21	5000-113	ROD: SHAKER, ASH GRATE, EQU	1
G	22	5000-103	BRACKET: HINGE, ASH DOOR, EQU	1
G	23	5000-131	LEVER: PRIMARY AIR, EQU	1
G	24	3900-185	HANDLE: WOOD,PRIM,EQU	1
G	25	5000-102	GUIDE WHEEL, ASH DRAWER, EQU	2
G	26	5240-136	SPRING: LATCH,FRONT,CHA 1/STO 1	1
G	27	5000-133	ROD: PRIMARY AIR, LINKAGE, EQU	1
G	28	2010-010	FRAME: ASH PAN,EQU	1
G	29	5000-110	SUPPORT: ASH GRATE, EQU	1
E,F,G	30	5000-320	PLATE: HINGE, DOOR, EQU	6
G	31	4500-2505	STUD: 3/8-16x1-3/8,FULLY THREADED	1
G	32	2010-017	HANDLE: DOOR,ASH PAN,EQU	1
G	33	2010-015	DOOR: ASH PAN,EQU	1
G	34	2010-020	BOTTOM: MATTE,EQU	1
G	35	5000-120	PAN: ASH DRAWER, EQU	1
G	36	5000-121	PAN: ASH TRAY, EQU	1
G	37	5000-122	PAN, ASH COVER, EQU	1
G	38	5000-123	HANDLE, ASH COVER, EQU	1
G	39	5000-130	PLATE: PRIMARY AIR, EQU	1
G	40	5000-135	SHUTTER: HOLD DOWN, PRIMARY AIR, EQU	1
G	41	2010-025	BASE: ASH GRATE,EQU	1
G	42	2010-027	GRATE: ASH,EQU	1
G	43	1-0000-002	STONE : REFRACTORY, 4"x1.6"x1-1/4",EQU	2
G	44	1-0000-001	STONE : REFRACTORY, 7-1/2"x4-1/2",EQU	4
E,F	45	3900-184	HANDLE: WOOD, EQU	2
E,F	46	5000-565	HANDLE CRANK: BLACK NICKEL, EQU	2
E,F	47	5240-138	SPRING: LATCH,WOOD STOVES,325#	2



E,F	48	5021-032	"WASHER: FLAT,-406""IDx1""ODx.035""T,BLK	2
E,F	49	4700-0792	"SPACER: DOOR LATCH,0.560""x0.500""x0.03	6
E,F	50	5000-322	LATCH, DOOR, FRONT, EQU	2
F	51	2010-075	DOOR: FRONT,MATTE,EQU	1
F	52	5000-323	PIN: HINGE PLATE, DOOR, EQU	2
F	53	3030-048	"GLASS: 10.9"x19"x5mm,EQU"	1
F	54	3120-021	GASKET: GLASS CLIP,BLACK, HER 1/TRI	8
F	55	5021-060	CLIP: GLASS,HER 1/TRI	8
F	56	2010-070	FRAME: DOOR,FRONT,EQU	1
F	57	5000-104	"BUSHING: DOOR, 3/8""x1/2"" ,BRASS(7815K1	2
F	58	2010-040	PLENUM: AIR,PRIMARY,EQU	1
E	59	2010-055	DOOR: SIDE,MATTE,EQU	1
E	60	1041-030	STONE: POL, ,SIDE DOOR,11.125"x9.5"x.45",EQU	1
E	61	2010-057	PLATE: STONE RETAINER,SIDE DOOR,EQU	1
E	62	5000-325	SHAFT:HINGE,L, EQU	1
E	63	5000-105	BUSHING:SHOULDER,EQU	2
E	64	5000-106	SLEEVE,SPRING RETAINING,EQU	2
E	65	5240-142	SPRING:TORSION,SIDE DOOR,EQU	2
E	66	5000-324	SHAFT:HINGE,R, EQU	1
E	67	2010-045	FRAME: DOOR,SIDE,OUTER,EQU	1
E	68	2010-047	FRAME: DOOR,SIDE,INNER,EQU	1
E	69	5000-310	GUARD: ASH, SIDE DOOR, EQU	1
E	70	5350-032	CLIP: HINGE,SIDE DOOR,BEN	2
D	71	1041-050	STONE: POL,FBS,9.86"x3.75"x1.18",EQU	2
D	72	1041-020	STONE: POL,DB,9.375"x3.75"x1.18",EQU	3
D	73	1041-054	STONE: POL,FC,12.43"x4.25"x1.18",EQU	2
D	74	1041-025	STONE: POL,DT,9.375"x2.8"x1.18",EQU	3
D	75	1041-056	STONE: POL,FTS,9.86"x2.8"x1.18",EQU	2
D	76	1041-022	STONE: POL,DC,12.43"x2.3"x1.18",EQU	2
D	77	1041-015	STONE: POL,RC,9.5"x6.25"x6.25"x1.18",EQU	1
D	78	1041-010	STONE: POL,RS,9.7"x9.5"x1.18",EQU	4
D	79	1041-040	STONE: POL,S,9.7"x9.5"x1.18",EQU	6
	80	2010-065	PLATE: SIDE,EQU	1
	81	2010-030	LEG: SIDE,MATTE,EQU	4
	82	2010-067	TRIM: SIDE,MATTE,EQU	1
	83	5210-2320	ROD: THREAD,3/8-16x21",0.31"&2",H	4

Assembly	KEY	Component	Object description	QTY
A	1	2010-095	TOP: MATTE,EQU	1
A	2	5000-402	HEATSHIELD: TOP, EQU	1
A	3	2010-090	SUPPORT: TOP STONE,EQU	1
A	4	1041-060	STONE: POL,T,9.62"x8.99"x1.18"EQU	2
A	5	1041-070	STONE: POL,T(LG),12.03x9.62x1.18"EQU	3
A	6	2010-082	COLLAR: FLUE EXIT,EQU	1
B	7	5000-301	PIPE: AIR, SECONDARY RISER, EQU	1
B	8	2010-085	PLENUM: AIR,SECONDARY,BOTTOM,EQU	1
B	9	5000-581	AIR TUBE 1: SECONDARY, EQU	1
B	10	5000-582	AIR TUBE 2: SECONDARY, EQU	1
B	11	5000-583	AIR TUBE 3: SECONDARY, EQU	1
B	12	5000-584	AIR TUBE 4: SECONDARY, EQU	1
B	13	2010-087	PLENUM: AIR,SECONDARY,TOP,EQU	1
B	14	3120-001	BOARD: CERAMIC,BAFFLE,EQU	1
B	15	5021-066	BRACKET: BAFFLE,SS,HER 1	1
B	16	5000-401	SUPPORT: BAFFLE, EQU	1
C	17	2010-080	FRAME: FLUE,MATTE,EQU	1
C	18	2010-081	PLATE: FLUE,EQU	1
G	19	2010-005	FOOT: MATTE,EQU	4
G	21	5000-113	ROD: SHAKER, ASH GRATE, EQU	1
G	22	5000-103	BRACKET: HINGE, ASH DOOR, EQU	1
G	23	5000-131	LEVER: PRIMARY AIR, EQU	1
G	24	3900-185	HANDLE: WOOD,PRIM,EQU	1
G	25	5000-102	GUIDE WHEEL, ASH DRAWER, EQU	2
G	26	5240-136	SPRING: LATCH,FRONT,CHA 1/STO 1	1
G	27	5000-133	ROD: PRIMARY AIR, LINKAGE, EQU	1
G	28	2010-010	FRAME: ASH PAN,EQU	1
G	29	5000-110	SUPPORT: ASH GRATE, EQU	1
E,F,G	30	5000-320	PLATE: HINGE, DOOR, EQU	6
G	31	4500-2505	STUD: 3/8-16x1-3/8,FULLY THREADED	1
G	32	2010-017	HANDLE: DOOR,ASH PAN,EQU	1
G	33	2010-015	DOOR: ASH PAN,EQU	1
G	34	2010-020	BOTTOM: MATTE,EQU	1
G	35	5000-120	PAN: ASH DRAWER, EQU	1
G	36	5000-121	PAN: ASH TRAY, EQU	1
G	37	5000-122	PAN, ASH COVER, EQU	1
G	38	5000-123	HANDLE, ASH COVER, EQU	1
G	39	5000-130	PLATE: PRIMARY AIR, EQU	1
G	40	5000-135	SHUTTER: HOLD DOWN, PRIMARY AIR, EQU	1
G	41	2010-025	BASE: ASH GRATE,EQU	1
G	42	2010-027	GRATE: ASH,EQU	1
G	43	1-0000-002	STONE : REFRACTORY, 4"x1.6"x1-1/4",EQU	2
G	44	1-0000-001	STONE : REFRACTORY, 7-1/2"x4-1/2",EQU	4
E,F	45	3900-184	HANDLE: WOOD, EQU	2
E,F	46	5000-565	HANDLE CRANK: BLACK NICKEL, EQU	2
E,F	47	5240-138	SPRING: LATCH,WOOD STOVES,325#	2

E,F	48	5021-032	"WASHER: FLAT,-406""IDx1""ODx.035""T,BLK	2
E,F	49	4700-0792	"SPACER: DOOR LATCH,0.560""x0.500""x0.03	6
E,F	50	5000-322	LATCH, DOOR, FRONT, EQU	2
F	51	2010-075	DOOR: FRONT,MATTE,EQU	1
F	52	5000-323	PIN: HINGE PLATE, DOOR, EQU	2
F	53	3030-048	"GLASS: 10.9"x19"x5mm,EQU"	1
F	54	3120-021	GASKET: GLASS CLIP,BLACK, HER 1/TRI	8
F	55	5021-060	CLIP: GLASS,HER 1/TRI	8
F	56	2010-070	FRAME: DOOR,FRONT,EQU	1
F	57	5000-104	"BUSHING: DOOR, 3/8""x1/2"" ,BRASS(7815K1	2
F	58	2010-040	PLENUM: AIR,PRIMARY,EQU	1
E	59	2010-055	DOOR: SIDE,MATTE,EQU	1
E	60	1041-030	STONE: POL, ,SIDE DOOR,11.125"x9.5"x.45",EQU	1
E	61	2010-057	PLATE: STONE RETAINER,SIDE DOOR,EQU	1
E	62	5000-325	SHAFT:HINGE,L, EQU	1
E	63	5000-105	BUSHING:SHOULDER,EQU	2
E	64	5000-106	SLEEVE,SPRING RETAINING,EQU	2
E	65	5240-142	SPRING:TORSION,SIDE DOOR,EQU	2
E	66	5000-324	SHAFT:HINGE,R, EQU	1
E	67	2010-045	FRAME: DOOR,SIDE,OUTER,EQU	1
E	68	2010-047	FRAME: DOOR,SIDE,INNER,EQU	1
E	69	5000-310	GUARD: ASH, SIDE DOOR, EQU	1
E	70	5350-032	CLIP: HINGE,SIDE DOOR,BEN	2
D	71	1041-050	STONE: POL,FBS,9.86"x3.75"x1.18",EQU	2
D	72	1041-020	STONE: POL,DB,9.375"x3.75"x1.18",EQU	3
D	73	1041-054	STONE: POL,FC,12.43"x4.25"x1.18",EQU	2
D	74	1041-025	STONE: POL,DT,9.375"x2.8"x1.18",EQU	3
D	75	1041-056	STONE: POL,FTS,9.86"x2.8"x1.18",EQU	2
D	76	1041-022	STONE: POL,DC,12.43"x2.3"x1.18",EQU	2
D	77	1041-015	STONE: POL,RC,9.5"x6.25"x6.25"x1.18",EQU	1
D	78	1041-010	STONE: POL,RS,9.7"x9.5"x1.18",EQU	4
D	79	1041-040	STONE: POL,S,9.7"x9.5"x1.18",EQU	6
	80	2010-065	PLATE: SIDE,EQU	1
	81	2010-030	LEG: SIDE,MATTE,EQU	4
	82	2010-067	TRIM: SIDE,MATTE,EQU	1
	83	5210-2320	ROD: THREAD,3/8-16x21",0.31"&2",H	4