



6" x 89" OSCILLATING EDGE SANDER



MODEL: KC-689-OSC & KC-689-OSC-7

INSTRUCTION MANUAL

COPYRIGHT © 2005 ALL RIGHTS RESERVED BY KING CANADA TOOLS INC.



IMPORTANT INFORMATION

**2-YEAR
LIMITED WARRANTY
FOR THIS OSCILLATING EDGE SANDER**

**KING CANADA TOOLS
OFFERS A 2-YEAR LIMITED WARRANTY
FOR INDUSTRIAL USE.**

PROOF OF PURCHASE

Please keep your dated proof of purchase for warranty and servicing purposes.

REPLACEMENT PARTS

Replacement parts for this tool are available at our authorized KING CANADA service centers across Canada. For servicing, contact or return to the retailer where you purchased your product along with your proof of purchase.

LIMITED TOOL WARRANTY

KING CANADA makes every effort to ensure that this product meets high quality and durability standards. KING CANADA warrants to the original retail consumer a 2-year limited warranty as of the date the product was purchased at retail and that each product is free from defects in materials. Warranty does not apply to defects due directly or indirectly to misuse, abuse, negligence or accidents, repairs or alterations and lack of maintenance. KING CANADA shall in no event be liable for death, injuries to persons or property or for incidental, special or consequential damages arising from the use of our products. To take advantage of this warranty, the product or part must be returned for examination by the retailer. Shipping and handling charges may apply. If a defect is found, KING CANADA will either repair or replace the product.

PARTS DIAGRAM & PARTS LISTS

Refer to the Parts section of the King Canada web site for the most updated parts diagram and parts list.

KING CANADA TOOLS INC. DORVAL, QUEBEC, CANADA H9P 2Y4

GENERAL SAFETY INSTRUCTIONS



VOLTAGE WARNING: Before connecting the tool to a power source (receptacle, outlet, etc.) be sure the voltage supplied is the same as that specified on the nameplate of the tool. A power source with voltage greater than that for the specified tool can result in **SERIOUS INJURY** to the user - as well as damage to the tool. If in doubt **DO NOT PLUG IN THE TOOL**. Using a power source with voltage less than the nameplate is harmful to the motor.

1. KNOW YOUR TOOL

Read and understand the owners manual and labels affixed to the tool. Learn its application and limitations as well as its specific potential hazards.

2. GROUND THE TOOL.

This tool is equipped with an approved 3-conductor cord and a 3-prong grounding type plug to fit the proper grounding type receptacle. The green conductor in the cord is the grounding wire. **NEVER** connect the green wire to a live terminal.

3. KEEP GUARDS IN PLACE.

Keep in good working order, properly adjusted and aligned.

4. REMOVE ADJUSTING KEYS AND WRENCHES.

Form habit of checking to see that keys and adjusting wrenches are removed from tool before turning it on.

5. KEEP WORK AREA CLEAN.

Cluttered areas and benches invite accidents. Make sure the floor is clean and not slippery due to wax and sawdust build-up.

6. AVOID DANGEROUS ENVIRONMENT.

Don't use power tools in damp or wet locations or expose them to rain. Keep work area well lit and provide adequate surrounding work space.

7. KEEP CHILDREN AWAY.

All visitors should be kept a safe distance from work area.

8. MAKE WORKSHOP CHILD-PROOF.

Use padlocks, master switches or remove starter keys.

9. USE PROPER SPEED.

A tool will do a better and safer job when operated at the proper speed.

10. USE RIGHT TOOL.

Don't force the tool or the attachment to do a job for which it was not designed.

11. WEAR PROPER APPAREL.

Do not wear loose clothing, gloves, neckties or jewelry (rings, watch) because they could get caught in moving parts. Non-slip footwear is recommended. Wear protective hair covering to contain long hair. Roll up long sleeves above the elbows.

12. ALWAYS WEAR SAFETY GLASSES.

Always wear safety glasses (ANSI Z87.1). Everyday eyeglasses only have impact resistant lenses, they are **NOT** safety glasses.

Also use a face or dust mask if cutting operation is dusty.

13. DON'T OVERREACH.

Keep proper footing and balance at all times.

14. MAINTAIN TOOL WITH CARE.

Keep tools sharp and clean for best and safest performance.

Follow instructions for lubricating and changing accessories.

15. DISCONNECT TOOLS.

Before servicing, when changing accessories or attachments.

16. AVOID ACCIDENTAL STARTING.

Make sure the switch is in the "OFF" position before plugging in.

17. USE RECOMMENDED ACCESSORIES.

Consult the manual for recommended accessories. Follow the instructions that accompany the accessories. The use of improper accessories may cause hazards.

18. NEVER STAND ON TOOL.

Serious injury could occur if the tool tips over. Do not store materials such that it is necessary to stand on the tool to reach them.

19. CHECK DAMAGED PARTS.

Before further use of the tool, a guard or other parts that are damaged should be carefully checked to ensure that they will operate properly and perform their intended function. Check for alignment of moving parts, breakage of parts, mounting, and any other conditions that may affect its operation. A guard or other parts that are damaged should be properly repaired or replaced.

20. NEVER LEAVE MACHINE RUNNING

UNATTENDED.

Turn power "OFF". Don't leave any tool running until it comes to a complete stop.



ELECTRICAL CONNECTIONS

WARNING

ALL ELECTRICAL CONNECTIONS MUST BE DONE BY A QUALIFIED ELECTRICIAN. FAILURE TO COMPLY MAY RESULT IN SERIOUS INJURY! ALL ADJUSTMENTS OR REPAIRS MUST BE DONE WITH THE EDGE SANDER DISCONNECTED FROM THE POWER SOURCE. FAILURE TO COMPLY MAY RESULT IN SERIOUS INJURY!

POWER SUPPLY

WARNING: YOUR EDGE SANDER MUST BE CONNECTED TO A 220V, 20-AMP. MINIMUM BRANCH CIRCUIT. FAILURE TO CONNECT IN THIS WAY CAN RESULT IN INJURY FROM SHOCK OR FIRE.

GROUNDING

This edge sander must be grounded. If it should malfunction or breakdown, grounding provides a path of least resistance for electric current, to reduce the risk of electric shock. This edge sander is equipped with a cord having an equipment-grounding conductor and grounding plug. The plug must be plugged into an appropriate outlet that is properly installed and grounded in accordance with all local codes and ordinances.

WARNING: TO MAINTAIN PROPER GROUNDING OF YOUR EDGE SANDER, DO NOT REMOVE OR ALTER THE GROUNDING PRONG IN ANY MANNER.

Not all outlets are properly grounded. If you are not sure if your outlet is properly grounded, have it checked by a qualified electrician.

WARNING: IF NOT PROPERLY GROUNDED, THIS EDGE SANDER CAN CAUSE ELECTRICAL SHOCK, PARTICULARLY WHEN USED IN DAMP LOCATIONS. TO AVOID SHOCK OR FIRE, IF THE POWER CORD IS WORN OR DAMAGED IN ANY WAY, HAVE IT REPLACED IMMEDIATELY.

220V OPERATION

As received from the factory, your edge sander is ready to run for 220V operation. This edge sander is intended for use on a circuit that has an outlet and a plug which looks like the one illustrated in Fig.1.

WARNING: DO NOT USE TWO-PRONG ADAPTORS FOR THEY ARE NOT IN ACCORDANCE WITH LOCAL CODES AND ORDINANCES. NEVER USE IN CANADA.

110V OPERATION

If 110V, single phase operation is desired, the following instructions must be followed:

1. Disconnect the machine from its power source.
2. The edge sander comes with four motor leads that are connected for 220V operation. Reconnect these four motor leads for 110V operation, as indicated on the inside of the capacitor cover.
3. The 220V plug supplied with the edge sander must be replaced with a CSA listed plug suitable for 110V operation. This plug is illustrated in Fig.2. Contact your authorized service center or qualified electrician to install the plug and to change the connections from 220V to 110V. The edge sander must comply with all local and national codes after the 110V plug is installed.
4. An edge sander with a 110V plug should only be connected to an

outlet having the same configuration as illustrated by the grounded outlet box in Fig.2. No adaptor is available or should be used for 220V operation.

EXTENSION CORDS

The use of any extension cord will cause some loss of power. Use the following table to determine the minimum wire size (A.W.G.-American Wire Gauge) extension cord. Use only 3-wire extension cords which have 3-prong grounding type plugs and 3-hole receptacles which accept the tool's plug.

For circuits that are further away from the electrical circuit box, the wire size must be increased proportionately in order to deliver ample voltage to the edge sander motor. Refer to Fig.3 for wire length and size.

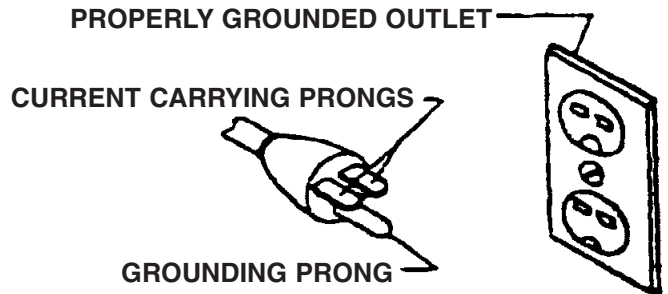

FIGURE 1

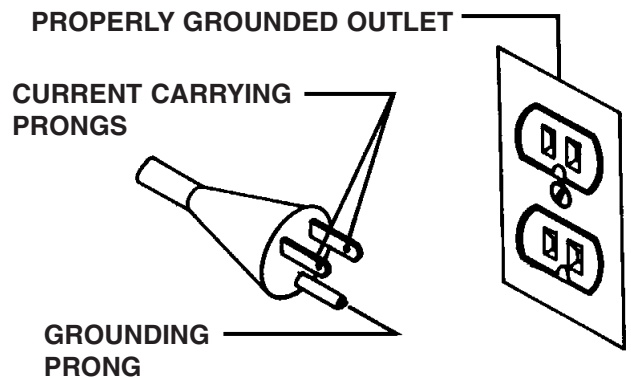

FIGURE 2

<u>LENGTH OF CONDUCTOR</u>	<u>WIRE SIZES REQUIRED (AMERICAN WIRE GAUGE)</u>
	<u>220V LINES</u>
0-25 FEET	NO.16
26-50 FEET	NO.14
51-100 FEET	NO.12

FIGURE 3

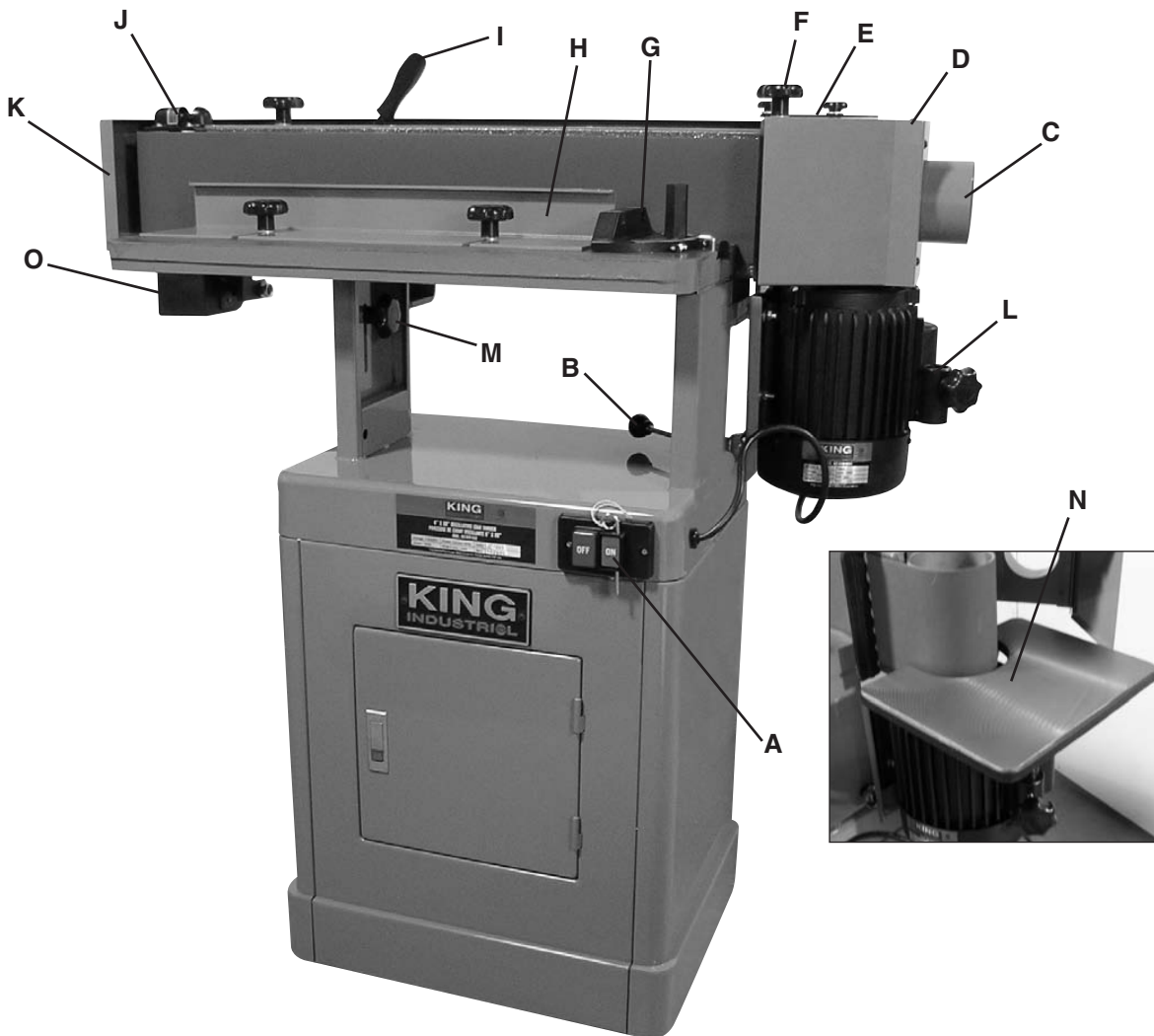

FIGURE 4

Getting to know your Edge Sander

A-On/Off Switch. Turns the machine on or off.

B-Belt Frame Lock Knob. Allows the operator to position the belt frame in a horizontal or vertical position.

C-4" Dust Chute. Adapt a dust collection system to minimize air born dust.

D-End Table Belt Guard. Protects the operator when in place, when it is opened, it exposes the right end of the sanding belt. It allows you to install the end table for contour sanding operations.

E-Workstop. Resting a workpiece against the workstop will prevent it from being projected in the air accidentally during horizontal or vertical operations. Also prevents the workpiece from entering and jamming inside the main belt guard.

F-Workstop Lock Knob. Locks the workstop in place.

G-Miter Gauge. Allows miter angle sanding operations.

H-Fence. When the fence is used in horizontal sanding operations, place workpiece between the fence and the sanding belt for

additional support and for safety purposes. When the fence is used in vertical sanding operations, it allows for setting thickness or sanding tapers.

I-Sanding Belt Tension Lever. Tensions the sanding belt after sanding belt replacement or adjustment.

J-Belt Tracking Mechanism. Adjusts the tracking of the sanding belt.

K-Small Belt Guard. Protects the operator from the rear of the sanding belt.

L-End Table Mounting Bracket. If contour sanding is desired, open end table belt guard and install the end table to the end table mounting bracket.

M-Table Height Adjustment Lock Knobs (2). These lock knobs allow you to set the height of the work table. Make sure they are tightened at all times.

N-End Table. Rest your workpiece on the end table during contour sanding.



ASSEMBLY, ADJUSTMENTS & OPERATIONS

Assembly

Mounting Tension Handle on Tension Lever

- 1) Place tension handle (A-Fig.5) over the tension lever (B-Fig.5).

Mounting Workstop to Belt Frame

- 1) Mount the workstop (C-Fig.5) to the right side of the belt frame using the lock knob (D-Fig.5).

Mounting End Table

Note: The end table is used for contour sanding operations and requires the small belt cover (right side) to be opened to expose the right end of the sanding belt. Unlock the 2 small belt cover lock knobs on the top and pivot the small belt cover open.

- 1) Fasten the end table (C-Fig.6) to the end table post (D-Fig.6) using hex. bolt and hex. nut (E-Fig.6). Tighten the hex. bolt against the flat on the end table post.
- 2) Insert the end table post into the end table support bracket fixed to the motor and secure the end table to the desired height using lock knob (F-Fig.6).

Adjustments

Tilting Belt Frame

- 1) Disconnect the machine from the power source.
- 2) Pull belt frame lock knob (A-Fig.7) towards you to release the tension.
- 3) Tilt the belt frame to desired position, hold in place and push the lock knob backwards to relock it in place. Get precise angles by placing a combination square between the table and the sanding belt.

Belt Frame Lock Knob Tension Adjustment

After prolonged use, the belt frame lock knob tension may need to be adjusted. If the lock knob does not lock the belt frame securely or if the lock knob is too hard to lock into place, adjust as follows;

- 1) Disconnect the machine from the power source.
- 2) Pull belt frame lock knob (A-Fig.7) forward to release the tension.
- 3) Tilt the belt frame to a horizontal position, do not lock.
- 4) Adjust the eccentric block tension of the lock knob by tightening or loosening the nylon hex. nut (A-Fig.8). Turn the nylon hex. nut in 1/4 turn increments and verify the adjustment for proper tension.

Important Note: When the belt frame lock knob is locked, the belt frame and motor assembly can not move. If it does, readjust lock knob tension.

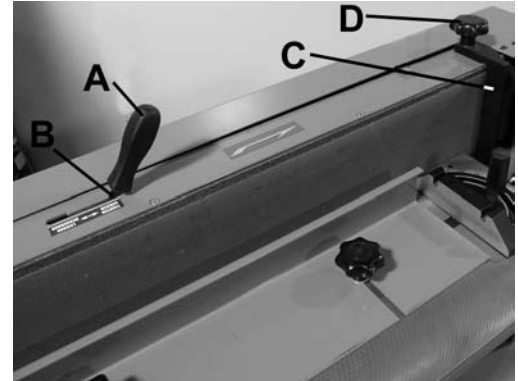

FIGURE 5

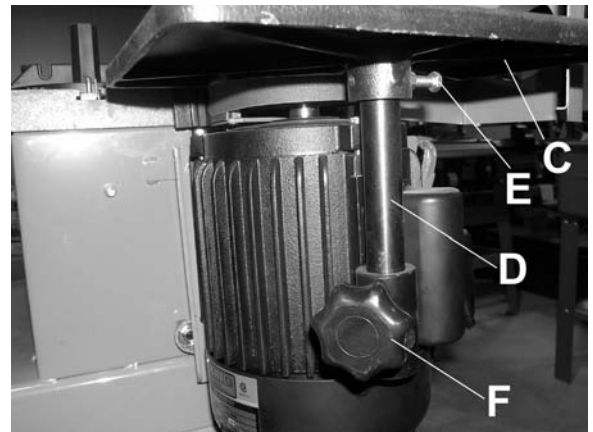

FIGURE 6

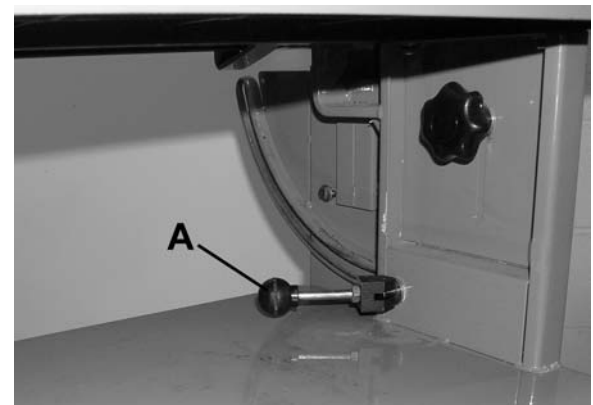

FIGURE 7



FIGURE 8

ADJUSTMENTS & OPERATIONS



Changing the Sanding Belt

- 1) Disconnect the machine from the power source.
- 2) Lock the belt frame in a vertical position, see Fig.9.
- 3) Release the sanding belt tension by pulling the sanding belt tension lever (A-Fig.9) to the left.
- 4) Slide both the small belt cover (B-Fig.9) and the main belt cover (C-Fig.9) off the belt frame by removing the 2 belt cover lock knobs at the rear.
- 5) Remove the old sanding belt. Place the new sanding belt around the 2 rollers, making sure the direction arrow on the belt matches the direct indicator on the top of the main belt cover. Align the edge of the sanding belt with the edges of the rollers.
- 6) Tension the sanding belt by pulling the tension lever to the right.
- 7) Sanding belts stretch with wear. You may need to adjust the belt tracking with a new belt.
- 8) Reposition and lock the belt guards in place.



FIGURE 9

Belt Tracking Adjustment

- 1) Disconnect the machine from the power source.
- 2) Push the belt by hand in the direction indicated on the top of the main belt cover. Observe the belt position on the rollers. The edge of the belt should remain even with the edge of the rollers.
- 3) Insert the supplied belt tracking tool (A-Fig.10) into the micro adjusting nut (B-Fig.10) and turn away from you to loosen.
- 4) Turn the micro adjusting screw (C-Fig.10) in 1/4 turn increments until the belt is tracking evenly on the rollers when the belt is pushed by hand.
- 5) Retighten the micro adjusting nut.
- 6) Connect the machine to the power source.
- 7) Turn the power on but just enough to get the belt turning and turn the machine off. Repeat this and observe the tracking of the belt. Continue to adjust as necessary.
- 8) If it seems impossible to get the belt tracking properly, see the next section "Motor Mount Tracking Adjustment".

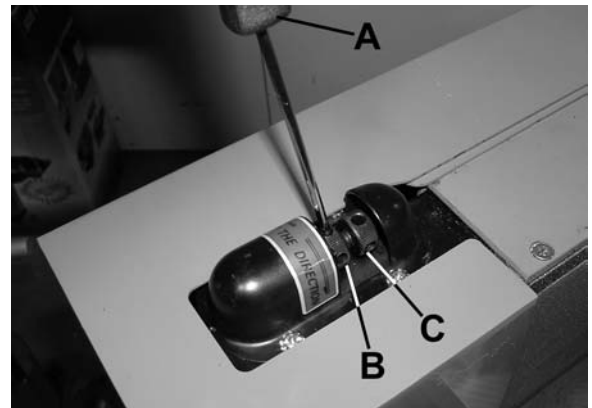

FIGURE 10

Motor Mount Tracking Adjustment

- 1) Disconnect the machine from the power source.
- 2) Slightly loosen the 4 motor mount hex. nuts (A-Fig.11) just enough so the motor mount tracking hex. nuts can be loosened.
- 3) Loosen both hex. nuts (B-Fig.11). Turn one hex. bolt (C-Fig.11) a 1/4 turn and push the belt by hand to observe the direction the belt is tracking. If the belt is traveling in the direction needed to correctly track the belt, tighten both hex. nuts (B-Fig.11) and fine tune the tracking with the belt tracking assembly on the belt frame.
- 4) If the belt starts to travel in the wrong direction, back off a 1/4 turn and tighten the other hex. bolt a 1/4 turn. This should start the belt in the proper direction.

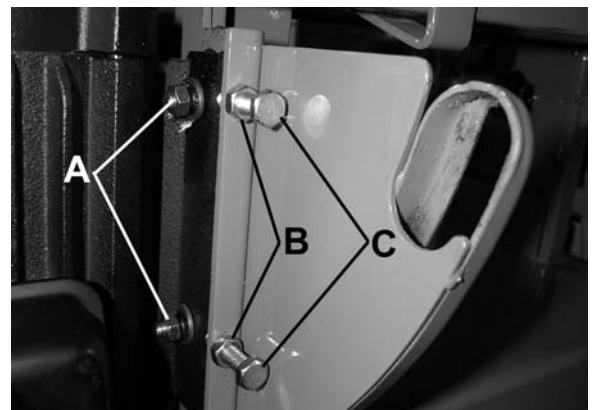

FIGURE 11

Note: Use the motor mount bolts as a "major" tracking adjustment. Use the belt tracking assembly on the belt frame as a "fine" tracking adjustment.



ADJUSTMENTS & OPERATIONS

Adjusting Table Height

WARNING! Do not position table below sanding belt! Keep an overlap of at least 1/16" between table and sanding belt to avoid material and/or fingers getting caught! Failure to comply may cause serious injury!

- 1) Loosen two lock knobs (A-Fig.12).
- 2) Raise or lower the work table to desired level.
- 3) Retighten two lock knobs.

Operation

WARNING! Removing the belt covers expose more of the sanding belt! Replace the belt covers immediately after completing any sanding that requires its removal! Failure to comply may cause serious injury!

Horizontal Sanding

- 1) With the belt frame locked in the horizontal position, the adjustable fence (A-Fig.13) may be used. The fence can be secured in place by screwing two lock knobs (B-Fig.13) into the guide blocks found in the miter slot (C-Fig.13).
- 2) The backstop (D-Fig.13) can also be used, place the backstop pin in the positioning hole and secure it in place with the workstop lock knob (E-Fig.1).

Vertical Sanding

- 1) With the belt frame locked in the vertical position, the backstop (A-Fig.13) and/or the miter gauge (B-Fig.14) may be used.
- 2) To set a miter gauge angle, loosen the lock handle (C-Fig.14), pivot the miter gauge body to the desired angle and retighten the lock handle. If you need to do precise 90° work use a square between the table and belt frame. Adjust for square.
- 3) The fence (A-Fig.13) can also be positioned for tapered sanding operations by setting the fence on an angle. Adjust the table so the fence is at a good height.

Contour Sanding

The use of the end table (A-Fig.15) is optional according to the particular function of the sanding operation. It is ideal for sanding curves.

- 1) Always rest your workpiece on the end table for support.
- 2) Reposition the end table height for maximum belt use by loosening the end table lock knob which fastens the end table post.
- 3) When the end table is not being used, remove the end table and post and store them inside the enclosed cabinet. The end belt cover should always be in place if the end table is not being used.

Connecting a Dust Collection System

To control the limit of airborne dust, it is highly recommended to connect a dust collection system to your edge sander. The belt cover on the right side has a 4" dust chute incorporated into it. Adapt a 4" hose from the edge sander to a dust collector for best results.

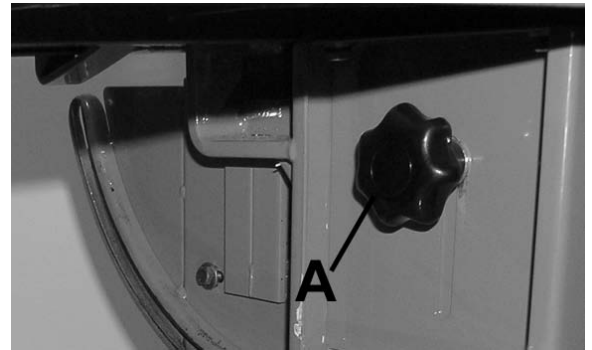

FIGURE 12

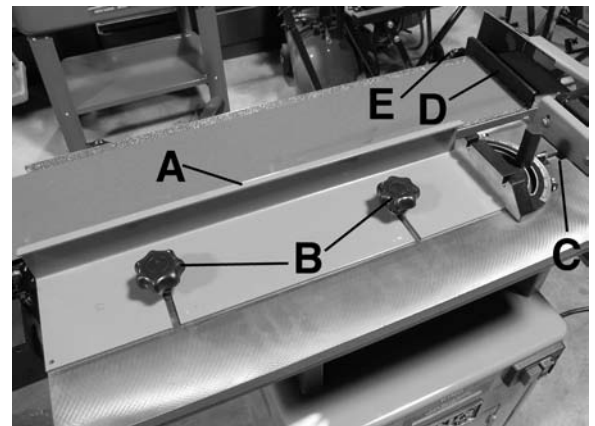

FIGURE 13

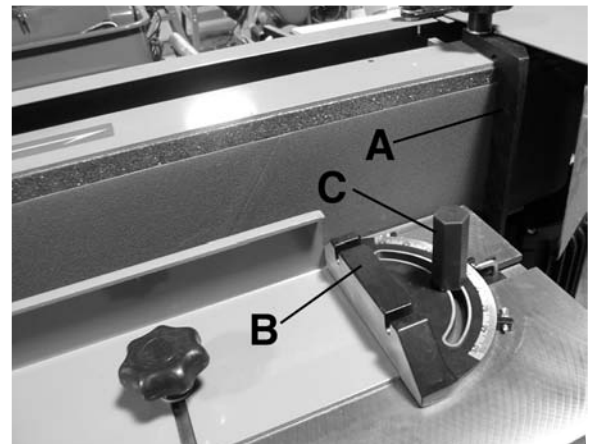

FIGURE 14

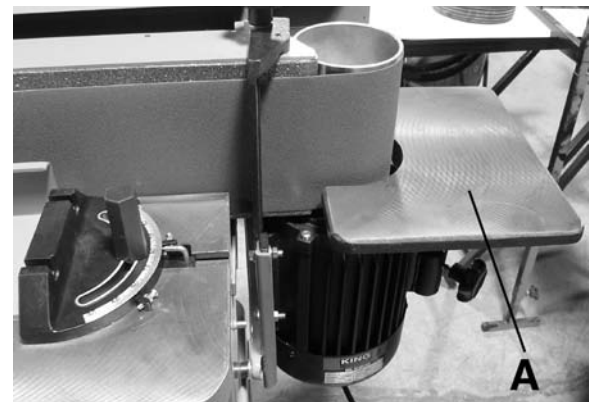

FIGURE 15