



15" INDUSTRIAL PLANER



MODEL: KC-385FX

INSTRUCTION MANUAL

COPYRIGHT © 2004 ALL RIGHTS RESERVED BY KING CANADA TOOLS INC.

IMPORTANT INFORMATION



**2-YEAR
LIMITED WARRANTY
FOR THIS 15" PLANER**

**KING CANADA TOOLS
OFFERS A 2-YEAR LIMITED WARRANTY
FOR INDUSTRIAL USE.**

PROOF OF PURCHASE

Please keep your dated proof of purchase for warranty and servicing purposes.

REPLACEMENT PARTS

Replacement parts for this tool are available at our authorized KING CANADA service centers across Canada. For servicing, contact or return to the retailer where you purchased your product along with your proof of purchase.

LIMITED TOOL WARRANTY

KING CANADA makes every effort to ensure that this product meets high quality and durability standards. KING CANADA warrants to the original retail consumer a 2-year limited warranty as of the date the product was purchased at retail and that each product is free from defects in materials. Warranty does not apply to defects due directly or indirectly to misuse, abuse, negligence or accidents, repairs or alterations and lack of maintenance. KING CANADA shall in no event be liable for death, injuries to persons or property or for incidental, special or consequential damages arising from the use of our products. To take advantage of this warranty, the product or part must be returned for examination by the retailer. Shipping and handling charges may apply. If a defect is found, KING CANADA will either repair or replace the product.

KING CANADA TOOLS INC. DORVAL, QUEBEC, CANADA H9P 2Y4



GENERAL & SPECIFIC SAFETY INSTRUCTIONS

VOLTAGE WARNING: Before connecting the tool to a power source (receptacle, outlet, etc.) be sure the voltage supplied is the same as that specified on the nameplate of the tool. A power source with voltage greater than that for the specified tool can result in **SERIOUS INJURY** to the user - as well as damage to the tool. If in doubt **DO NOT PLUG IN THE TOOL**. Using a power source with voltage less than the nameplate is harmful to the motor.

1. KNOW YOUR TOOL

Read and understand the owners manual and labels affixed to the tool. Learn its application and limitations as well as its specific potential hazards.

2. GROUND THE TOOL.

This tool is equipped with an approved 3-conductor cord and a 3-prong grounding type plug to fit the proper grounding type receptacle. The green conductor in the cord is the grounding wire. **NEVER** connect the green wire to a live terminal.

3. KEEP GUARDS IN PLACE.

Keep in good working order, properly adjusted and aligned.

4. REMOVE ADJUSTING KEYS AND WRENCHES.

Form habit of checking to see that keys and adjusting wrenches are removed from tool before turning it on.

5. KEEP WORK AREA CLEAN.

Cluttered areas and benches invite accidents. Make sure the floor is clean and not slippery due to wax and sawdust build-up.

6. AVOID DANGEROUS ENVIRONMENT.

Don't use power tools in damp or wet locations or expose them to rain. Keep work area well lit and provide adequate surrounding work space.

7. KEEP CHILDREN AWAY.

All visitors should be kept a safe distance from work area.

8. MAKE WORKSHOP CHILD-PROOF.

Use padlocks, master switches or remove starter keys.

9. USE PROPER SPEED.

A tool will do a better and safer job when operated at the proper speed.

10. USE RIGHT TOOL.

Don't force the tool or the attachment to do a job for which it was not designed.

11. WEAR PROPER APPAREL.

Do not wear loose clothing, gloves, neckties or jewelry (rings, watch) because they could get caught in moving parts. Non-slip footwear is recommended. Wear protective hair covering to contain long hair. Roll up long sleeves above the elbows.

12. ALWAYS WEAR SAFETY GLASSES.

Always wear safety glasses (ANSI Z87.1). Everyday eyeglasses only have impact resistant lenses, they are **NOT** safety glasses. Also use a face or dust mask if cutting operation is dusty.

13. DON'T OVERREACH.

Keep proper footing and balance at all times.

14. MAINTAIN TOOL WITH CARE.

Keep tools sharp and clean for best and safest performance. Follow instructions for lubricating and changing accessories.

15. DISCONNECT TOOLS.

Before servicing, when changing accessories or attachments.

16. AVOID ACCIDENTAL STARTING.

Make sure the switch is in the "OFF" position before plugging in.

17. USE RECOMMENDED ACCESSORIES.

Consult the manual for recommended accessories. Follow the instructions that accompany the accessories. The use of improper accessories may cause hazards.

18. NEVER STAND ON TOOL.

Serious injury could occur if the tool tips over. Do not store materials such that it is necessary to stand on the tool to reach them.

19. CHECK DAMAGED PARTS.

Before further use of the tool, a guard or other parts that are damaged should be carefully checked to ensure that they will operate properly and perform their intended function. Check for alignment of moving parts, breakage of parts, mounting, and any other conditions that may affect its operation. A guard or other parts that are damaged should be properly repaired or replaced.

20. NEVER LEAVE MACHINE RUNNING UNATTENDED.

Turn power "OFF". Don't leave any tool running until it comes to a complete stop.

ADDITIONAL SAFETY INSTRUCTIONS FOR 15" PLANER

1. **If you are not thoroughly familiar** with the operation of planers, obtain advice from your supervisor, instructor or other qualified person.

2. **Keep cutterhead** sharp and free of all rust and pitch.

3. **Check material** for loose knots, nails and other defects.

4. **Remove shavings** only with the power off.

5. **Keep hands away** from the top surface of the board near the feed rollers.

6. **Check that switch is in OFF** position before plugging in power cord.

7. **Before moving table** upward or downward, loosen table locking knobs. The locking knobs are on the right side of machine.

8. **Be sure the knives** of cutterhead are correct and all lock bolts are secured tightly before use.

9. **Keep hands away** from the feed rollers and the cutterhead.

10. **Do not operate** machine while the gear cover is open.

11. **Remove adjusting tools** and loose articles from machine before operating.

TECHNICAL INFORMATION & GETTING TO KNOW YOUR PLANER



TECHNICAL INFORMATION

Motor3HP, 220V, 1 Phase, 60Hz

Cutting Capacities:

Minimum Length of unbutted stock6.74"

Maximum width of stock15"

Maximum Thickness of stock8"

Planing depth (width under 8.3")Max- 0.23"

Planing depth (width from 8.3"-20")Max- 0.12"

Feed Rates16/30 FPM

Jackscrew Cutterhead:

Number of knives3

Diameter3"

Speed5,000 RPM

Cuts per minute15,000

Feed Rollers:

Spiral Infeed Diameter2"

Table rollersAdjustable

Table20" x 15"

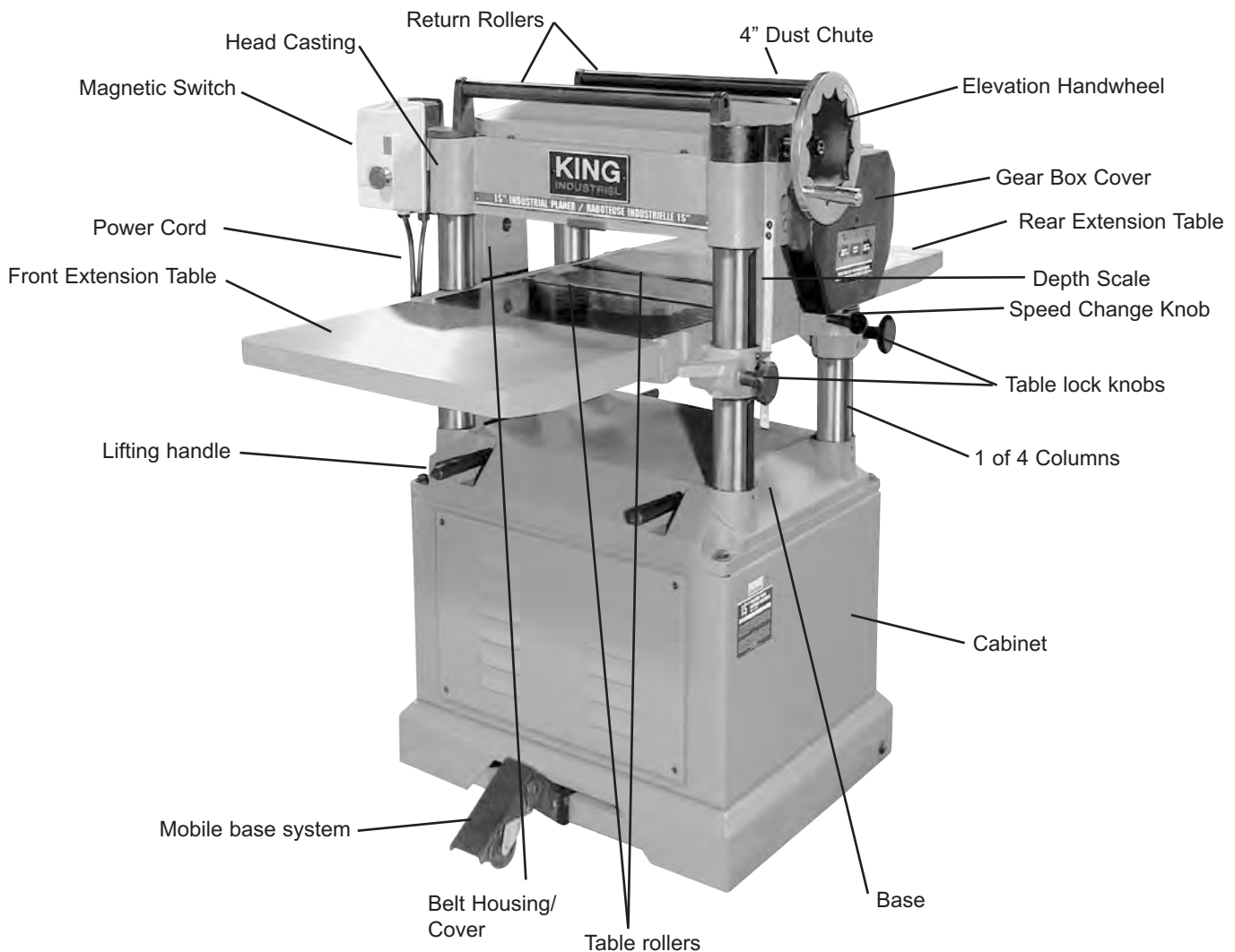



ELECTRICAL CONNECTIONS

WARNING!

ALL ELECTRICAL CONNECTIONS MUST BE DONE BY A QUALIFIED ELECTRICIAN. FAILURE TO COMPLY MAY RESULT IN SERIOUS INJURY! ALL ADJUSTMENTS OR REPAIRS MUST BE DONE WITH THE MACHINE DISCONNECTED FROM THE POWER SOURCE. FAILURE TO COMPLY MAY RESULT IN SERIOUS INJURY!

POWER SUPPLY

WARNING: YOUR PLANER MUST BE CONNECTED TO A 220V, 20 AMP. BRANCH CIRCUIT OR CIRCUIT BREAKER. FAILURE TO CONNECT IN THIS WAY CAN RESULT IN INJURY FROM SHOCK OR FIRE.

GROUNDING

This planer must be grounded. If it should malfunction or breakdown, grounding provides a path of least resistance for electric current, to reduce the risk of electric shock. This planer must be equipped with a cord having an equipment-grounding conductor and grounding plug. The plug must be plugged into an appropriate outlet that is properly installed and grounded in accordance with all local codes and ordinances.

Not all outlets are properly grounded. If you are not sure if your outlet is properly grounded, have it checked by a qualified electrician.

WARNING: IF NOT PROPERLY GROUNDED, THIS PLANER CAN CAUSE ELECTRICAL SHOCK, PARTICULARLY WHEN USED IN DAMP LOCATIONS. TO AVOID SHOCK OR FIRE, IF THE POWER CORD IS WORN OR DAMAGED IN ANY WAY, HAVE IT REPLACED IMMEDIATELY.

WARNING: TO MAINTAIN PROPER GROUNDING OF YOUR PLANER, DO NOT REMOVE OR ALTER THE GROUNDING PRONG IN ANY MANNER.

220V OPERATION

As received from the factory, your planer is ready to operate on 220V circuit. This planer is intended for use on a circuit that has an outlet and a plug which looks like the one illustrated in Fig.1.

WARNING: DO NOT USE A TWO-PRONG ADAPTOR FOR THEY ARE NOT IN ACCORDANCE WITH LOCAL CODES AND ORDINANCES. NEVER USE IN CANADA.

A 220V plug is not supplied with the planer and must be purchased at your local hardware store. The 220V plug must be a CSA listed plug suitable for 220V operation. This plug is illustrated in Fig.1. Contact your authorized service center or qualified electrician to install the plug. The planer must comply with all local and national codes after the 220V plug is installed.

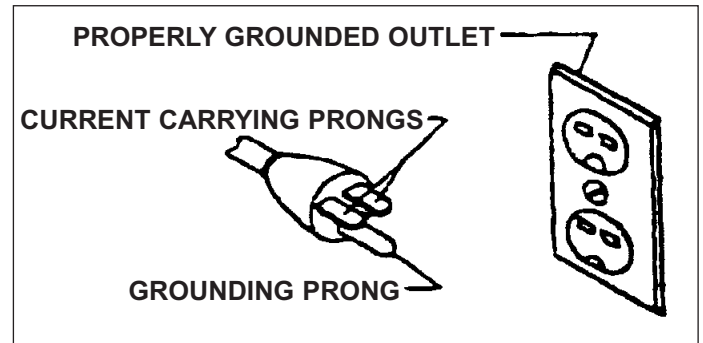

FIGURE 1

UNPACKING & MOVING YOUR PLANER



UNPACKING AND CLEANUP

To ensure maximum performance from your planer, clean it properly and install it accurately before use.

As soon as you receive the planer, we recommend you follow these procedures :

1. Inspect packing crate for damage in transit. Record damage and report it immediately to shipping company or retailer.
2. Open crate and check that machine arrived in good condition. If not, let your industrial retailer know immediately.
3. Before lifting machine, remove all bolts locking it to its shipping base.
4. Transport machine to location with a hand truck, sling or dolly.
5. Remove the protective coating from the table, bed rolls, feed rolls, cutterhead and loose items packed with the machine, including lifting handles and motor pulley.
6. This coating may be removed with a soft cloth moistened with Kerosene.

NOTE : Do not use acetone, gasoline, or lacquer thinner for this purpose.

7. Do not use solvents on plastic parts; solvents dissolve and damage plastic.
8. Care must be taken when cleaning the cutterhead as the knives installed in the cutterhead and they are very sharp.

MOVING PLANER

Lifting Handles

There are four lifting handles to facilitate the transportation of your planer. All lifting handles are the pull out type. Pull the handles out for use, push them back in when not in use. Two of the lifting handles (A) are as shown in Fig.3 & Fig.4.

Lifting Planer

If any type of sling is used to lift machine, be sure to only attach the sling to the lifting handles. Be sure that machine is kept in level position while lifting, as shown in Fig.4.

This step must be done before the installation of solid extension tables.

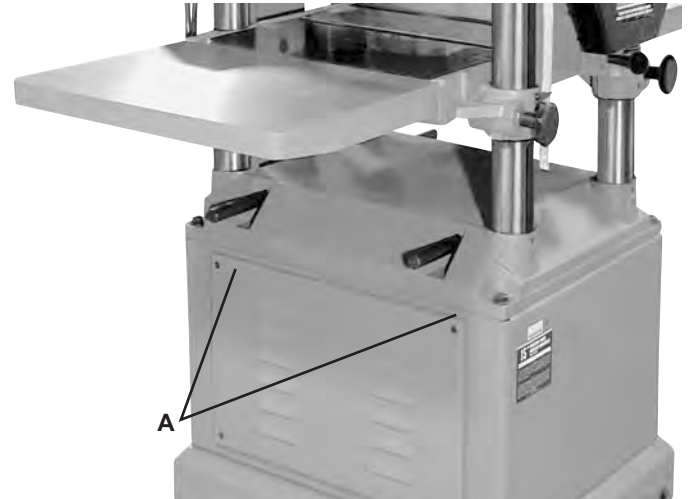

FIGURE 3

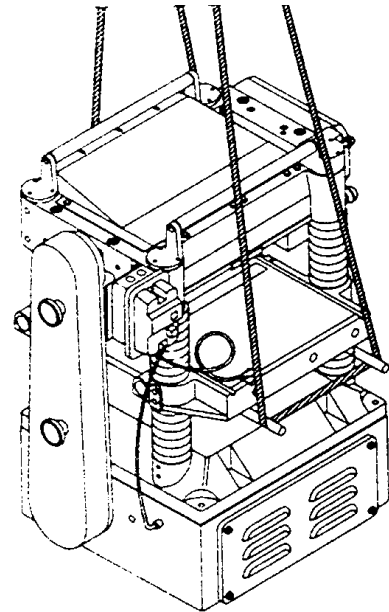

FIGURE 4

ASSEMBLING AND ALIGNING MOTOR, MOTOR PULLEY AND BELTS

1. Assemble the motor to the motor mounting plate, as shown in Fig.5.

NOTE : It is very important that the motor be mounted to motor plate by using the mounting hardware (A) Fig.5.

2. Assemble the motor pulley (H) to the motor shaft with the key in place and tighten the hex. bolt (3) in the motor shaft, as shown in Fig.6.

3. Using a straight edge, align the motor and cutterhead pulleys as shown in Fig.7, the motor plate (B) Fig.5 can be moved for alignment by loosening the set screws (C) in the motor plate (B) as shown in Fig.5.

4. Assemble the belts to the two pulleys, as shown in Fig.7. and adjust for the proper belt tension by raising or lowering the motor plate, as shown in Fig.8, then tighten the nuts (A) Fig.8. Correct tension is obtained when there is approx. 1/4" deflection of the center span of the pulleys by using light finger pressure on each belt.

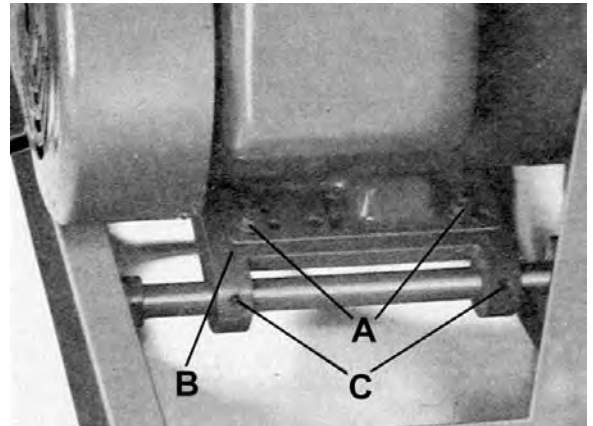
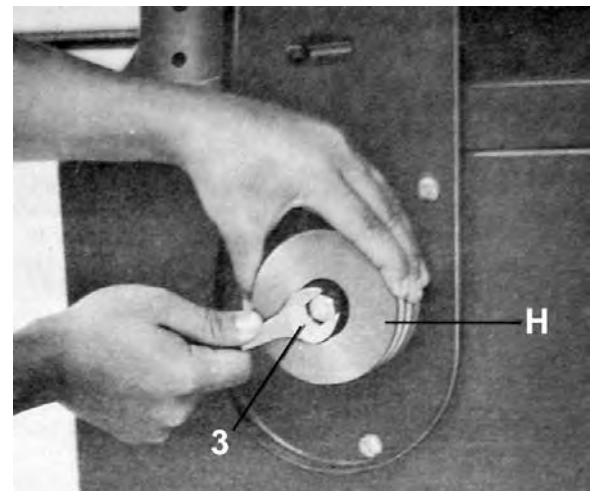
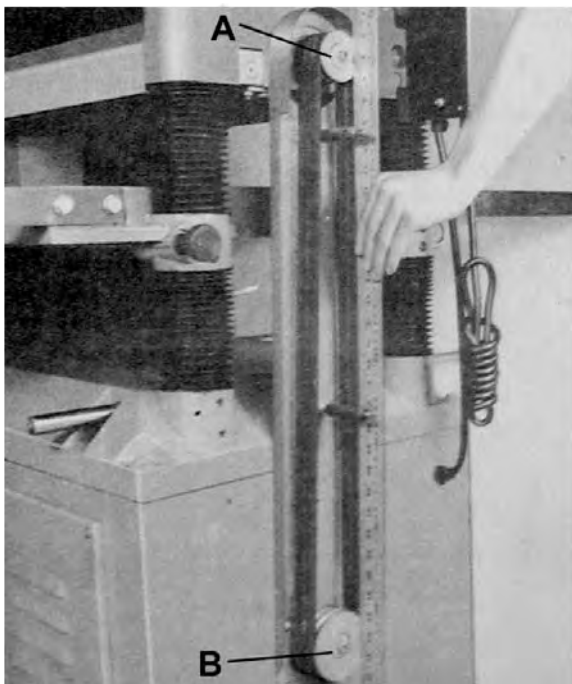
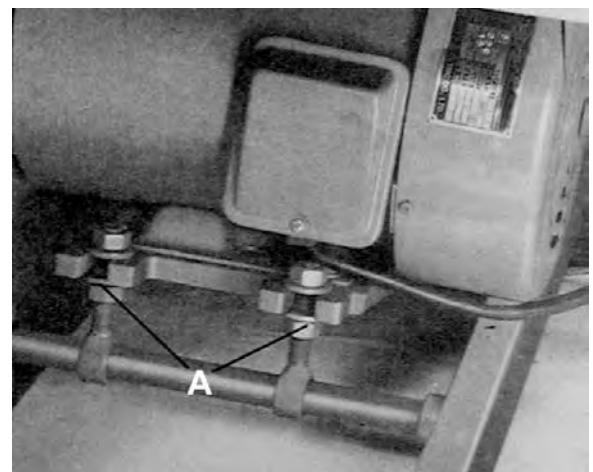
**FIGURE 5****FIGURE 6****FIGURE 7****FIGURE 8**

ASSEMBLY & ADJUSTMENTS



ADJUSTING TABLE ROLLERS

Your planer is supplied with two table rollers (A) Fig.9, which aid in feeding the stock by reducing friction and turn as the stock is fed through the planer. It is not possible to give exact dimensions on the proper height setting of the table rollers because each type of wood behaves differently.

As a general rule, when planing rough stock, the table rollers should be set at a high position, and when planing soft and smooth stock the table rollers should be set at a low position. The rollers should be set at the level which most reflects the planing you do, frequent adjustment of the table rollers may cause premature wear and tear.



FIGURE 9

NOTE: The raising range is between 0.003"-0.006" when raising the roller higher above the table as shown in Fig.10.

The table rollers on your planer are set for average planing and are parallel to the table surface. If you desire to adjust the table rollers higher or lower, proceed as follows;

1. Disconnect the planer from the power source.
2. Lay a straight edge (A) Fig.11 across both rollers, loosen both set screws (B) Fig.11, and turn the eccentric shafts (C) to raise or lower the table rollers, when the proper height is obtained tighten screws (B). The table rollers must be adjusted on the opposite end of the table in the same manner.

NOTE: Be sure that the height of the front and rear rollers are the same. The table rollers must always be set parallel to the table.

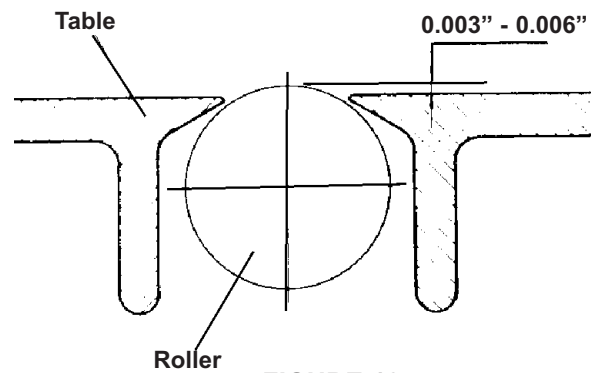

FIGURE 10

ASSEMBLING SOLID TABLE EXTENSIONS

Solid table extensions are supplied and can be assembled to the front and back of your planer table. To install the front extension table, hold the extension table against the front of the table and using hex. bolts and washers (A) Fig.12 supplied, fix the extension table to the table.

To adjust the extension table parallel with the table surface, place a straight edge on the top of the table and extension table. Adjust the position of the extension table by using the set screws (B) Fig.12 found underneath until the table extension and the main table are perfectly parallel.

Repeat the above steps for the rear extension table.

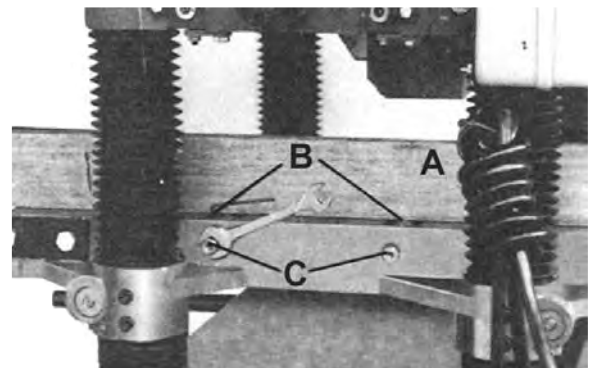

FIGURE 11

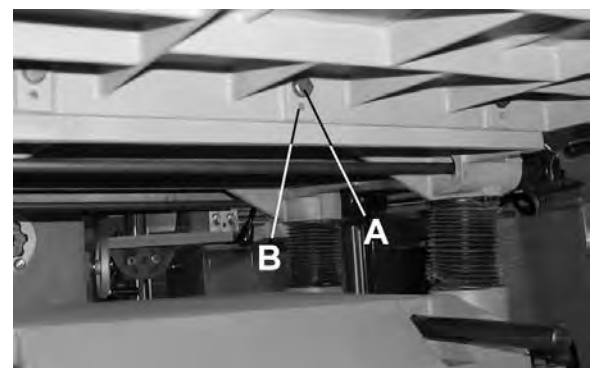

FIGURE 12



ASSEMBLY & ADJUSTMENTS

CONTROLLING THE DEPTH OF CUT

The cutting depth scale (A) Fig.13 includes a combination of inch/metric measurements with a cutting range from 0" to 8". The upward or downward movement is controlled by the handwheel (B). One turn of the handwheel will increase or decrease the height by 0.059" (1.5mm). Before attempting to move the position of the head up or down, loosen the lock knobs (C). Once the head is at the proper height, retighten lock knobs (C).

ADJUSTMENTS & TOOLS NEEDED

Although your planer was carefully adjusted at the factory, it should be checked before being put into operation. Any inaccuracies due to rough handling in transit can easily be corrected by following these directions. In order to check the adjustments you will need a straight edge, feeler gauge and a homemade gauge block made of hard wood. This gauge block can be made by following the dimensions shown in Fig.14.

CHECKING, ADJUSTING & REPLACING CUTTERHEAD KNIVES

WARNING! When checking adjustments, always make sure the planer is disconnected from the power source.

When checking, adjusting or replacing the cutterhead knives, proceed as follows;

1. Disconnect the planer from the power source.
 2. Remove the six screws (A) Fig.15, and remove the upper cover (B). Only 4 of the 6 screws are shown in Fig.15.
 3. To check and adjust knives, use the knife gauge (A) Fig.16 and check all three knives. Knives should just contact the bottom of the center protrusion (B) of the knife gauge, as shown in Fig.16.
 4. If an adjustment to one or more of the knives is necessary, slightly loosen the knife locking bars (C) Fig.16, of all three knives by turning the 5 locking bolts (D) Fig.16 of each knife locking bar into the knife locking bars just enough to relieve stress in the cutterhead and not disturb the setting of the knives.
 5. Using the knife gauge, adjust the knife that must be reset by loosening all 5 locking bolts (D) Fig.16, by turning them into the knife locking bar. The knife locking bar becomes loose and knife adjustment is now possible. Using the hex. key supplied, unscrew Jackscrews (E) located under the knife until the knife comes into contact with the center protrusion (B) of the knife gauge (A). Then snug up the knife locking bar by lightly backing out the 5 locking bolts (D) against the slot.
- NOTE: At this time, only tighten the knife enough to hold the knife in place. The knife will be secured properly once all other knives have been checked and adjusted.
6. If additional knives must be reset, repeat step 5.
 7. After all three knives are set with the bolts just snug, back out and tighten the 5 locking bolts against the slot starting with the end bolts first, then the center bolts until the knife is securely held in the cutterhead. Tighten the remaining two knives in the same manner.



FIGURE 13

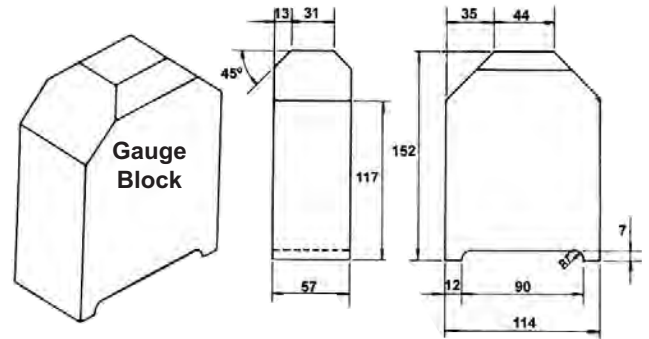

FIGURE 14

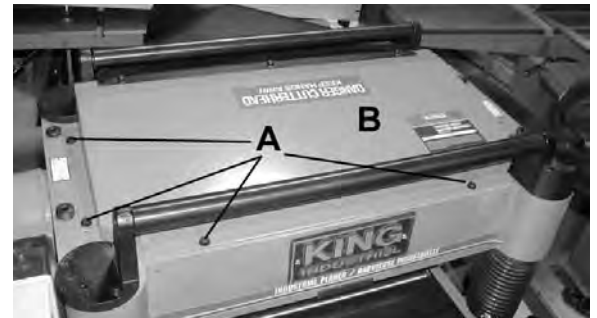

FIGURE 15

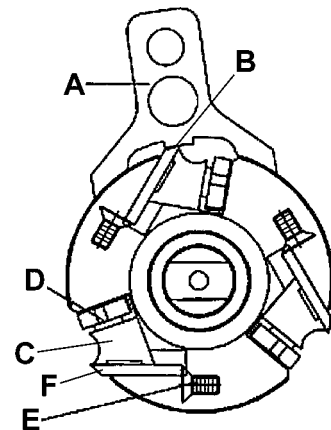

FIGURE 16

ASSEMBLY & ADJUSTMENTS



CHECKING WORK TABLE PARALLEL TO CUTTERHEAD

The work table is set parallel to the cutterhead at the factory and no further adjustment should be necessary. If your planer is planing a taper, first check to see if the knives are set properly in the cutterhead, proceed as follows;

1. Disconnect the planer from the power source.
2. Place the gauge block (A) Fig.17 on the work table directly under the front edge of the head casting (B), make slight contact by gently raising the table as shown in Fig.17.
3. Move the gauge block (A) to the opposite end of the work table as shown in Fig.18.

IMPORTANT: The distance from the work table to the edge of the head casting should be the same.

4. Adjust opposite end in the same manner.

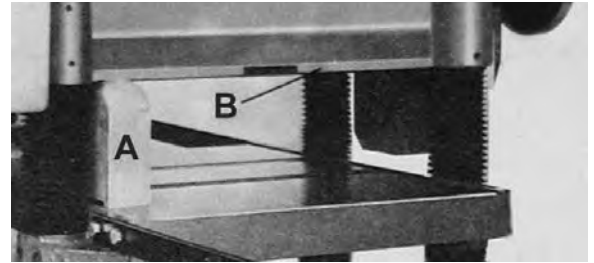

FIGURE 17

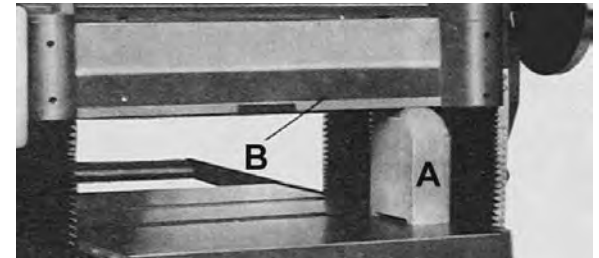

FIGURE 18

ADJUSTING WORK TABLE PARALLEL TO CUTTERHEAD

If the work table is not parallel to the cutterhead, perform the following adjustments;

1. Disconnect the planer from the power source.
2. Tilt planer on its side to expose the underside of the base as shown in Fig. 19.
3. Remove cap screw (A) and loosen cap screw (B) Fig.19, these two cap screws will allow you to move the idler sprocket assembly (C) far enough to release tension on the chain as shown in Fig.20.
4. Remove chain from the sprocket from the corner which needs adjusting. Fig.20 shows the chain removed from the sprocket (D).
5. Turn sprocket (D) by hand to bring that corner into adjustment with the other three corners.

IMPORTANT NOTE: Turning sprocket (D) clockwise will increase the distance between the work table and the head casting, counterclockwise will decrease the distance. This adjustment is very sensitive and it should not be necessary to turn the sprocket more than one or two teeth.

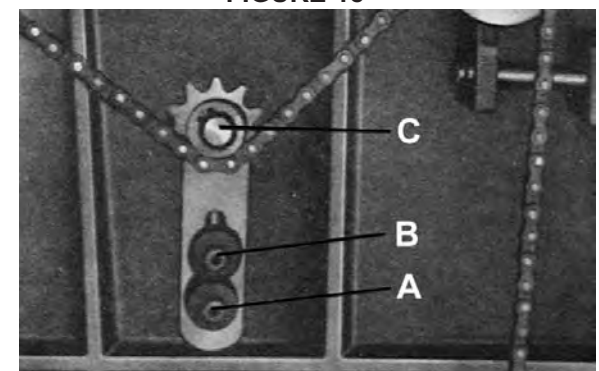

FIGURE 19

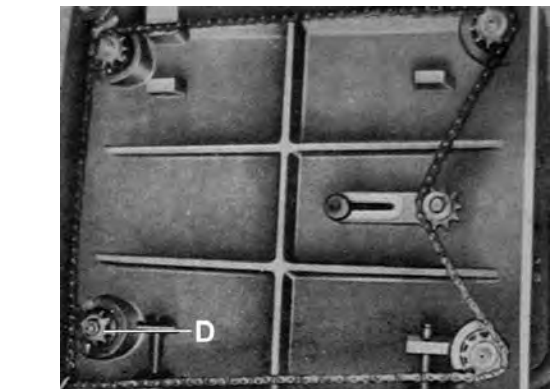

FIGURE 20

KNOWING THE TRANSMITTING ROLLERS OF YOUR PLANER

- A. Infeed roller
- B. Outfeed roller
- C. Chipbreaker
- D. Cutterhead
- E. Pressure bar
- F. Anti-kickback fingers

The infeed roller and outfeed roller feed the stock while it is being planed. Both these rollers are under spring tension and this tension must be sufficient to feed the stock uniformly through the planer without slipping but shouldn't be too tight that it causes damage to the workpiece. The tension should be equal at both ends of each roller.

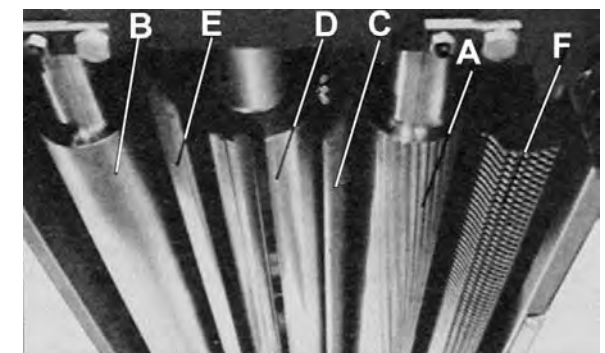

FIGURE 21

ADJUSTING INFEEED AND OUTFEED ROLLER SPRING TENSION

To adjust the spring tension of the infeed and outfeed roller, using a hex key, turn set screw (A) Fig.22 to adjust the infeed roller spring tension and set screw (B) to adjust the outfeed roller spring tension. Make sure that both sides are adjusted evenly or else you will get uneven feeding of stock.

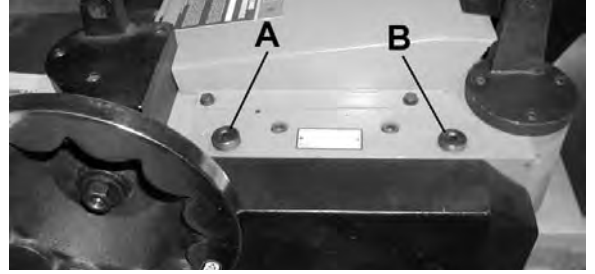

FIGURE 22

ANTI-KICKBACK FINGERS

Anti-kickback fingers (F) Fig.23 are provided for your safety to prevent workpiece kickbacks. These fingers operate by gravity and it is necessary to inspect them occasionally to make sure they are free of gum and pitch so that they can move independently and operate correctly.

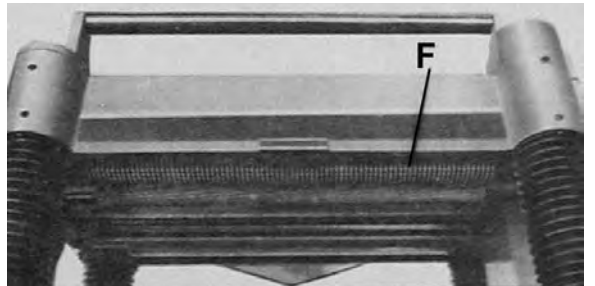

FIGURE 23

CHECKING AND ADJUSTING THE HEIGHT OF INFEEED ROLLER, CHIPBREAKER, PRESSURE BAR AND OUTFEED ROLLER

The infeed roller, chipbreaker, pressure bar and outfeed roller are adjusted at the factory. The infeed roller and the chipbreaker were set at 0.004", the pressure bar was set at 0.008" and the outfeed roller was set at 0.02" and all of them below the cutting circle as shown in Fig.24. If an adjustment to the infeed roller, chipbreaker, pressure bar or outfeed roller is necessary, follow the next steps;

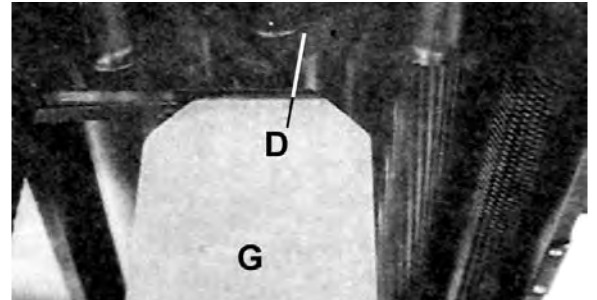

FIGURE 25

Example: To check and adjust the outfeed roller 0.02" below the cutting circle, proceed as follows;

1. Disconnect planer from power source.
2. Make sure the knives are adjusted properly before attempting the following adjustment.
3. Place the gauge block (G) on the table directly underneath the cutterhead, as shown in Fig.25. Using a 0.02" Feeler gauge (D) placed on top of the gauge block, raise the work table until the knife just touches the feeler gauge when the knife is at its lower point. Do not move the work table any further until the outfeed roller is adjusted.
4. Move the gauge block (G) under one end of the outfeed roller (B) as shown in Fig.26. The bottom of the outfeed roller should just touch the top of the gauge block. If an adjustment to the outfeed roller is necessary, loosen the lock nut (K) Fig.26 and turn screw (L) until the outfeed roller just touches the gauge block. Retighten lock nut (K).
5. Check and adjust the opposite end of the outfeed roller in the same manner.

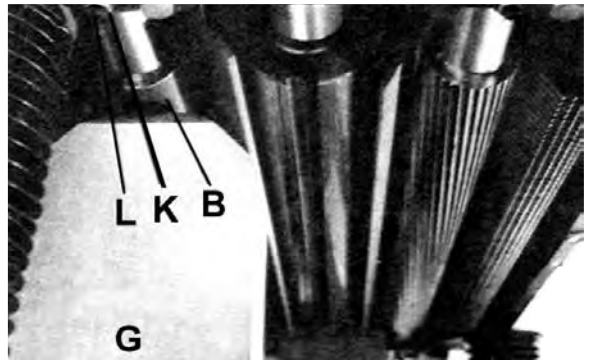

FIGURE 26

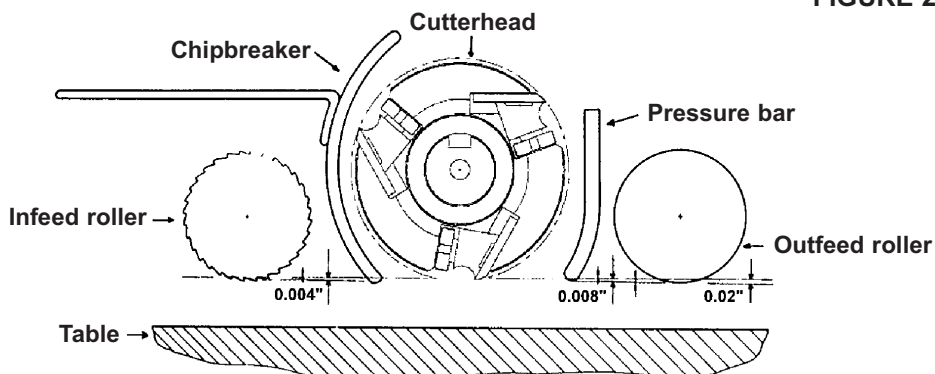

FIGURE 24

ASSEMBLY & ADJUSTMENTS



FEED SPEED CONTROL

Your planer is equipped with a spiral, serrated infeed roller and a solid steel outfeed roller. When the feed rollers are engaged, they turn to feed stock. The feed rollers slow down automatically when the planer is under heavy load. The feed rollers are driven by chains (D) Fig. 27 and the sprockets (E), which take power directly from the cutterhead through the oil gear box (F).

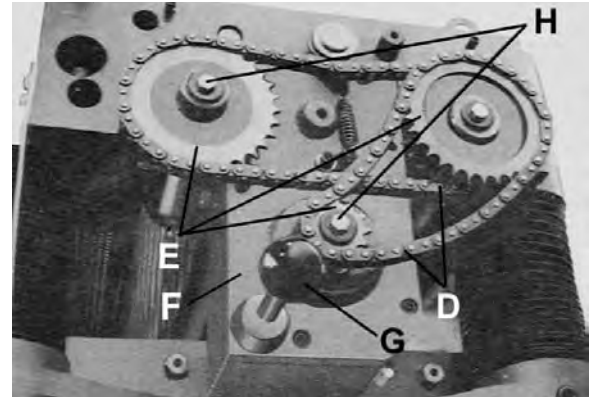

FIGURE 27

WARNING! ONLY CHANGE FEED SPEED WHEN THE MACHINE IS RUNNING.

There are two feed speeds in the gear box, they are controlled by using the speed shift lever (G) Fig.27. When the speed shift lever is completely pushed in (A) Fig.28, the feed speed rate is 30 ft./min., when it is completely pulled out (C) the feed speed rate is 16 ft./min. and the center position (B) is a neutral setting.

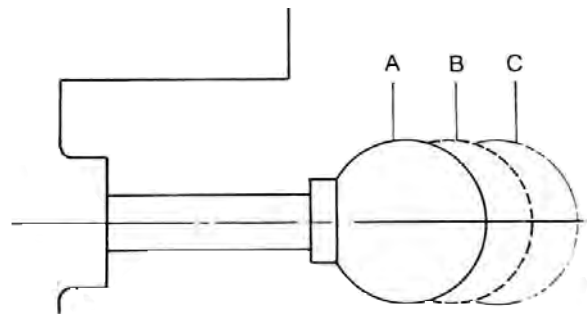

FIGURE 28

RETURN ROLLERS

The two return rollers (A) Fig. 29 on the top of the planer serve as a convenient stock rest. When planed lumber is returned to the infeed side, it saves time and motion.

4" DUST COLLECTOR HOOD

This standard accessory dust collector hood (B) Fig.29 is assembled to the rear of the planer using hex. bolts and washers. Connecting a dust collector to your planer provides an efficient means of maintaining a clean and safe work area. Good dust collection and chip removal is essential for smooth planing.

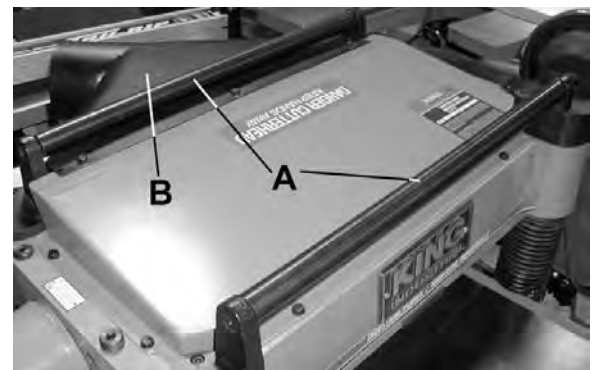

FIGURE 29



LUBRICATION

Below you will find lubrication instructions and maintenance intervals to maintain your planer in good working order. Failure to upkeep your planer as prescribed on this page will reduce its life span. The No. in chart below refers to the figures below.

Lubrication Guide for Industrial Planer KC-385FX

No.	Position	Interval	Suitable Types of Lubricants
1	Chains	Frequently	Grease
2	Gear Box	When operated more than 2,500 hours	HD-100, Mobil Gear 627, Shell Omala 100, ESSO Spartan EP-1004
3	Roller Brackets	Frequently	SAE-30
4	Worm Gear	Frequently	Grease
5	Lead Screws	Frequently	Grease
6	Columns	Frequently	SAE-30
7	Chain	Frequently	Grease
8	Bushings	Frequently	SAE-30

LUBRICATION GUIDE FOR GEAR BOX

The gear box lubricant must be replaced every 2,500 hours of operation. Suitable lubricant is multi-purpose gear box lubricant.

To replace oil in gear box:

1. Remove the drain plug (A) Fig.30 and oil level cap (B), drain dirty oil thoroughly.
2. Reposition and tighten the drain plug (A).
3. Remove cap screw (C) Fig.31 and pour oil through cap screw hole. Fill the gear box with oil until the oil starts coming out of the oil level cap hole (B).
4. Reposition and tighten the oil level cap (B) and the cap screw (C).

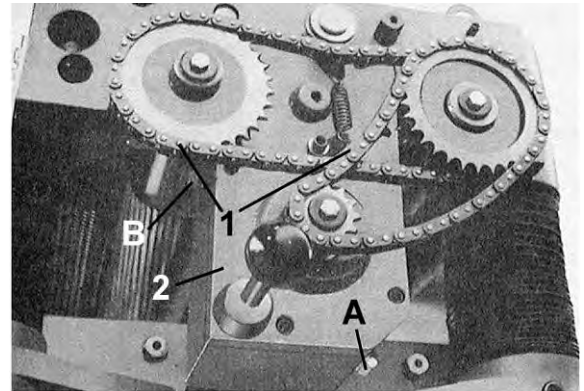

FIGURE 30

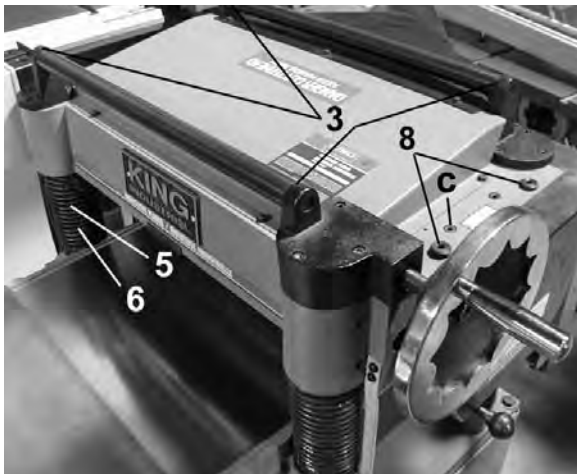

FIGURE 31

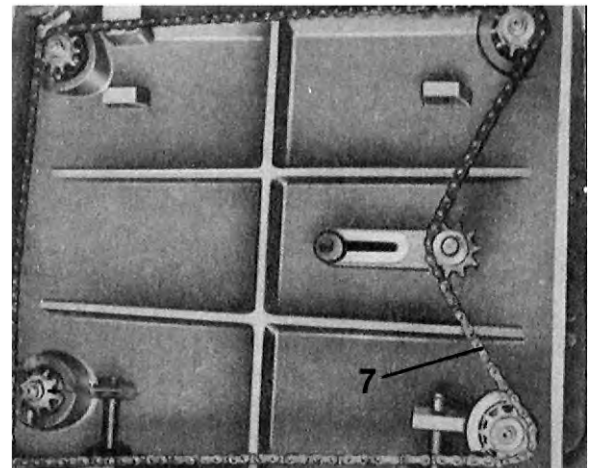

FIGURE 32

PARTS DIAGRAM & PARTS LISTS

Refer to the Parts section of the King Canada web site for the most updated parts diagram and parts list.