

03/2013



## 3" X 79" METAL BELT SANDER



MODEL: KC-379MS

# INSTRUCTION MANUAL

COPYRIGHT © 2012 ALL RIGHTS RESERVED BY KING CANADA TOOLS INC.



## WARRANTY INFORMATION

**2-YEAR  
LIMITED WARRANTY  
FOR THIS METAL BELT SANDER**

**KING CANADA TOOLS  
OFFERS A 2-YEAR LIMITED WARRANTY  
FOR COMMERCIAL USE.**

### **PROOF OF PURCHASE**

Please keep your dated proof of purchase for warranty and servicing purposes.

### **REPLACEMENT PARTS**

Replacement parts for this product are available at our authorized King Canada service centers across Canada.

### **LIMITED TOOL WARRANTY**

King Canada makes every effort to ensure that this product meets high quality and durability standards. King Canada warrants to the original retail consumer a 2-year limited warranty as of the date the product was purchased at retail and that each product is free from defects in materials. Warranty does not apply to defects due directly or indirectly to misuse, abuse, normal wear and tear, negligence or accidents, repairs done by an unauthorized service center, alterations and lack of maintenance. King Canada shall in no event be liable for death, injuries to persons or property or for incidental, special or consequential damages arising from the use of our products.

To take advantage of this limited warranty, return the product at your expense together with your dated proof of purchase to an authorized King Canada service center. Contact your retailer or visit our web site at [www.kingcanada.com](http://www.kingcanada.com) for an updated listing of our authorized service centers. In cooperation with our authorized serviced center, King Canada will either repair or replace the product if any part or parts covered under this warranty which examination proves to be defective in workmanship or material during the warranty period.

### **NOTE TO USER**

This instruction manual is meant to serve as a guide only. Specifications and references are subject to change without prior notice.

### **PARTS DIAGRAM & PARTS LISTS**

Refer to the Parts section of the King Canada web site for the most updated parts diagram and parts list.

**KING CANADA INC. DORVAL, QUÉBEC, CANADA H9P 2Y4**

**[www.kingcanada.com](http://www.kingcanada.com)**

# GENERAL SAFETY INSTRUCTIONS FOR POWER TOOLS



## 1. KNOW YOUR TOOL

Read and understand the owners manual and labels affixed to the tool. Learn its application and limitations as well as its specific potential hazards.

## 2. GROUND THE TOOL.

This tool is equipped with an approved 3-conductor cord and a 3-prong grounding type plug to fit the proper grounding type receptacle. The green conductor in the cord is the grounding wire. **NEVER** connect the green wire to a live terminal.

## 3. KEEP GUARDS IN PLACE.

Keep in good working order, properly adjusted and aligned.

## 4. REMOVE ADJUSTING KEYS AND WRENCHES.

Form habit of checking to see that keys and adjusting wrenches are removed from tool before turning it on.

## 5. KEEP WORK AREA CLEAN.

Cluttered areas and benches invite accidents. Make sure the floor is clean and not slippery due to wax and sawdust build-up.

## 6. AVOID DANGEROUS ENVIRONMENT.

Don't use power tools in damp or wet locations or expose them to rain. Keep work area well lit and provide adequate surrounding work space.

## 7. KEEP CHILDREN AWAY.

All visitors should be kept a safe distance from work area.

## 8. MAKE WORKSHOP CHILD-PROOF.

-with padlocks, master switches or by removing starter keys.

## 9. USE PROPER SPEED.

A tool will do a better and safer job when operated at the proper speed.

## 10. USE RIGHT TOOL.

Don't force the tool or the attachment to do a job for which it was not designed.

## 11. WEAR PROPER APPAREL.

Do not wear loose clothing, gloves, neckties or jewelry (rings, watch) because they could get caught in moving parts. Non-slip footwear is recommended. Wear protective hair covering to contain long hair. Roll up long sleeves above the elbows.

## 12. ALWAYS WEAR SAFETY GLASSES.

Always wear safety glasses (ANSI Z87.1). Everyday eyeglasses only have impact resistant lenses, they are **NOT** safety glasses. Also use a face or dust mask if operation is dusty.

## 13. DON'T OVERREACH.

Keep proper footing and balance at all times.

## 14. MAINTAIN TOOL WITH CARE.

Keep tools sharp and clean for best and safest performance. Follow instructions for lubricating and changing accessories.

## 15. DISCONNECT TOOLS.

Before servicing, when changing accessories or attachments.

## 16. AVOID ACCIDENTAL STARTING.

Make sure the switch is in the "OFF" position before plugging in.

## 17. USE RECOMMENDED ACCESSORIES.

Consult the manual for recommended accessories. Follow the instructions that accompany the accessories. The use of improper accessories may cause hazards.

## 18. NEVER STAND ON TOOL.

Serious injury could occur if the tool tips over. Do not store materials such that it is necessary to stand on the tool to reach them.

## 19. CHECK DAMAGED PARTS.

Before further use of the tool, a guard or other parts that are damaged should be carefully checked to ensure that they will operate properly and perform their intended function. Check for alignment of moving parts, breakage of parts, mounting, and any other conditions that may affect its operation. A guard or other parts that are damaged should be properly repaired or replaced.

## 20. NEVER LEAVE MACHINE RUNNING UNATTENDED.

Turn power "OFF". Don't leave any tool running until it comes to a complete stop.

## SPECIFIC SAFETY INSTRUCTIONS FOR YOUR METAL BELT SANDER

- 1) This machine is designed and intended for use by properly trained and experienced personnel only. If you are not familiar with the proper use of metal sanders, do not use this machine until proper training and knowledge has been obtained.
- 2) Keep guards in place. Belt guards must be kept in place and in working order all the times to ensure safety.
- 3) Use proper respirator. Always use proper respirator while operating this metal sander.
- 4) Wear proper apparel. Loose clothing, gloves, neckties, bracelets, or other jewelry may get caught in moving parts. Non-slip footwear is recommended. Wear protective hair covering to contain long hair.
- 5) Always wear ASME safety glasses. For the safety of your eyes, safety glasses should be used while operating the metal sander.
- 6) Hearing protection. Always wear proper hearing safety equipment while operating this metal sander.
- 7) Dust collection system. Do not operate this metal sander without

connecting to a proper metal dust collection system that is rated for metal dust collection.

- 8) Flammable materials. Sanding metal causes sparks. Make sure there is no flammable material close to the sander during operation.
- 9) Grasp the stock with both hands. Feed it into the machine with light pressure against the direction of rotation of the belt. Do not sand pointed or tapered stock with the point facing the feed direction and never sand more than one piece of stock at a time.
- 10) Be careful. Do not place your hands close to the sanding belt while the machine is running.
- 11) Turn the power OFF. Before making any adjustments, make sure the switch is in the "OFF" position and the cord is unplugged from the power source.
- 12) Make sure you have read and understood all the safety instructions in the manual and you are familiar with your metal sander, before operating it. If you fail to do so, serious injury could occur.



# ELECTRICAL INFORMATION

## WARNING!

ALL ADJUSTMENTS OR REPAIRS MUST BE DONE WITH THE METAL BELT SANDER DISCONNECTED FROM THE POWER SOURCE. FAILURE TO COMPLY MAY RESULT IN SERIOUS INJURY!

### GENERAL INFORMATION- 220V single phase operation

This metal belt sander comes with a 2 HP 220V single phase motor.

**WARNING:** YOUR METAL BELT SANDER MUST BE CONNECTED TO A 220V-240V, 1 PHASE ELECTRICAL SUPPLY. FAILURE TO CONNECT IN THIS WAY CAN RESULT IN INJURY FROM SHOCK OR FIRE.

This metal belt sander is intended for use on an electrical circuit that has an outlet and a plug which looks like the one illustrated in Fig.1.

**WARNING:** DO NOT USE A TWO-PRONG ADAPTOR FOR THEY ARE NOT IN ACCORDANCE WITH LOCAL CODES AND ORDINANCES. NEVER USE IN CANADA.

### GROUNDING

Your metal belt sander must be properly grounded. Not all outlets are properly grounded. If you are not sure if your outlet is properly grounded, have it checked by a qualified electrician. If it should malfunction or breakdown, grounding provides a path of least resistance for electric current, to reduce the risk of electric shock. This metal belt sander is equipped with a cord having an equipment-grounding conductor and grounding plug. The plug must be plugged into an appropriate outlet that is properly installed and grounded in accordance with all local codes and ordinances.

**WARNING:** TO MAINTAIN PROPER GROUNDING OF YOUR METAL BELT SANDER, DO NOT REMOVE OR ALTER THE GROUNDING PRONG IN ANY MANNER.

**WARNING:** IF NOT PROPERLY GROUNDED, THIS CYCLONE DUST COLLECTOR CAN CAUSE ELECTRICAL SHOCK, PARTICULARLY WHEN USED IN DAMP LOCATIONS. TO AVOID SHOCK OR FIRE, IF THE POWER CORD IS WORN OR DAMAGED IN ANY WAY, HAVE IT REPLACED IMMEDIATELY.

### EXTENSION CORDS

The use of an extension cord is generally not recommended for 220V-240V operation. The use of any extension cord will cause some loss of power. Use the table (Fig.2) to determine the minimum wire size (A.W.G.-American Wire Gauge) extension cord needed. Use only 3-wire extension cords which have 3-prong grounding type plugs and 3-hole receptacles which accept the tool's plug.

For circuits that are further away from the electrical circuit box, the wire size must be increased proportionately in order to deliver ample voltage to the metal belt sander motor. Refer to Fig.2 for wire length and size.

### RESET BUTTON

This metal belt sander comes with a thermal overload protector, when the motor is overloaded the reset button (A) Fig.3 will trip and the motor will turn off. Allow the motor to cool down for a few minutes before attempting to restart the motor. Press the rest button (A) and press the On button on the main switch to restart motor.

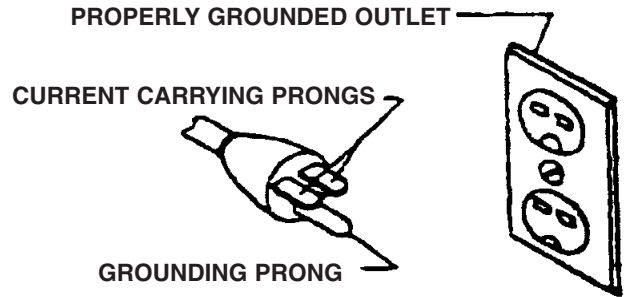

FIGURE 1

<u>LENGTH OF EXTENSION CORD</u>	<u>WIRE SIZES REQUIRED (AMERICAN WIRE GAUGE) 220V-240V LINES ONLY</u>
0-25 FEET	NO.16
26-50 FEET	NO.16
51-100 FEET	NO.14

FIGURE 2

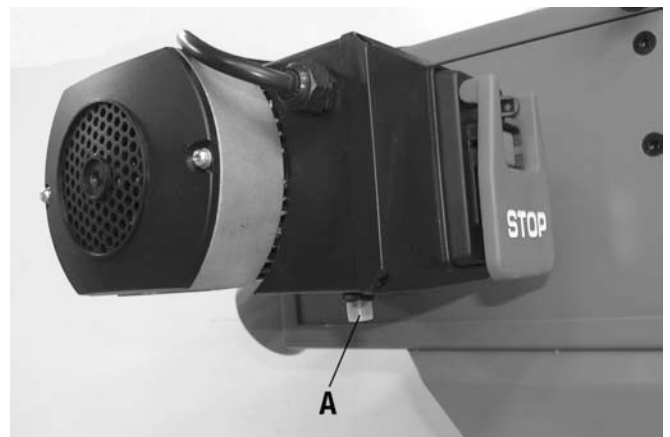
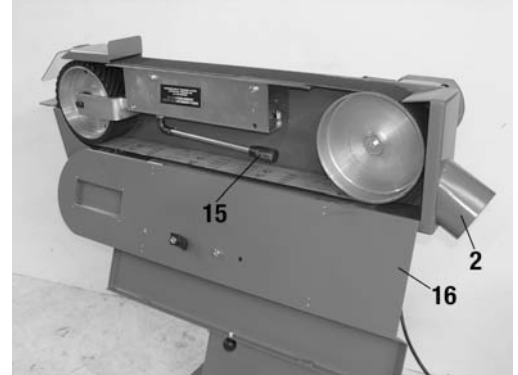

FIGURE 3

# GETTING TO KNOW YOUR METAL BELT SANDER



1. 2HP, 240V Motor
2. Rear dust port (3")
3. Sanding belt cover
4. Work stop
5. Transparent safety guard
6. Sanding belt
7. Work support
8. Front dust port (3")
9. Front dust port lock handle
10. Sanding belt tracking knob
11. Tracking knob locking cap screw
12. Angle adjustment lock lever
13. Off button
14. On button
15. Sanding belt tension lever
16. Rear cover

## SPECIFICATIONS

MODEL .....	KC-379MS
HORSEPOWER .....	2 HP
VOLTAGE .....	240V
AMPERAGE .....	9 A
R.P.M .....	3,400
Hz .....	60
PHASE .....	1
BELT .....	3" X 78-3/4"
BELT SPEED .....	6,900 ft/min
BELT TILT ANGLE .....	0-60°



# ASSEMBLY

## Installing work support and front dust port

1. Install the work support assembly (A) Fig.4 to the frame (B) of the machine, first place 2 washers between the frame and the work support arm (C).
2. Then secure the work support assembly to the frame using 2 hex. bolts, lock washers and washers (D).

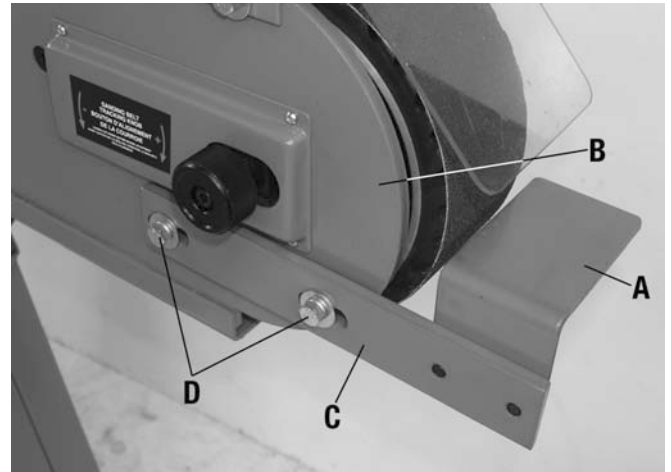

FIGURE 4

## Installing front dust port

1. Install the front dust port (A) Fig.5 to the slot underneath the frame (B) and secure it using the spring loaded lock handle and large washer (C).

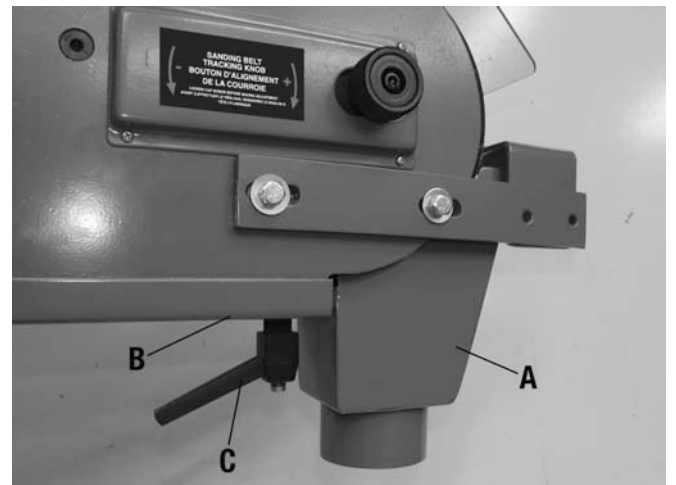

FIGURE 5

## Dust collection

This metal belt sander features two 3" dust ports (A & B) Fig.6 for dust collection. Connect fire rated hoses to the dust ports and a metal dust collector. For your own safety, and to prevent risks of fire, make sure the dust collection system as well as the hoses are fire rated for metal dust collection.

## Securing to shop floor

Once this machine is completely assembled, it is highly recommended to secure the base of this metal belt sander to the shop floor (Floor securing hardware not included). The base features four mounting holes (C) Fig.6, make sure the machine is positioned in an ideal working location and the base is level before securing base.

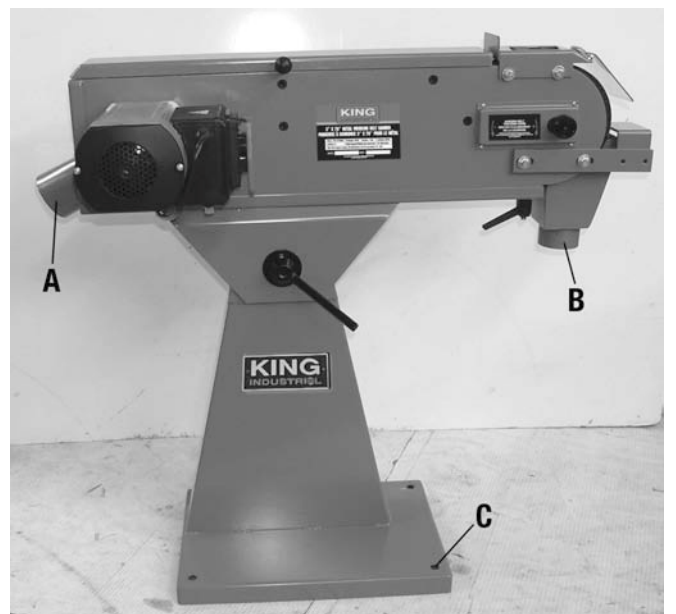

FIGURE 6

# ADJUSTMENTS & OPERATION



## Sanding belt angle adjustment

The angle of the metal belt sander can be adjusted from 0°- 60° for various sanding operations.

1. Loosen the angle adjustment lever (A) Fig.7.
2. Position the belt sander head (B) in the desired angle and retighten the angle adjustment lever.

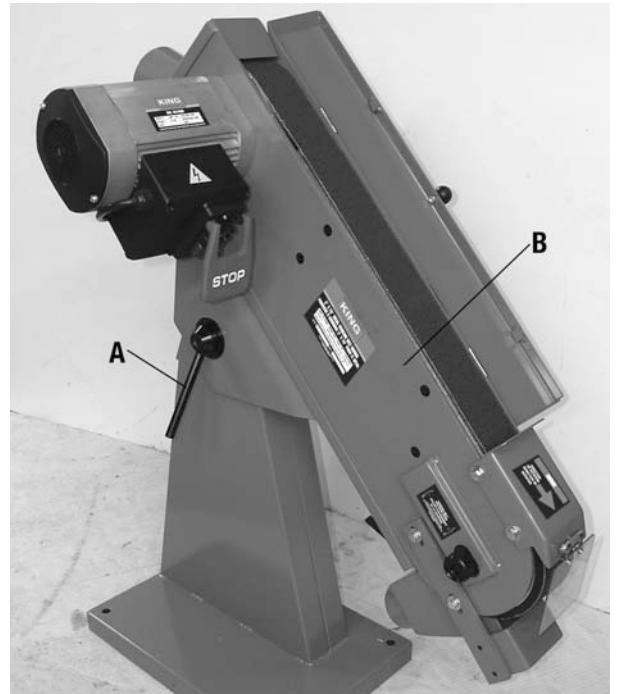

FIGURE 7

## Sanding belt tracking adjustment

Sanding belt tracking adjustment means to adjust the belt centered on the rollers so that it runs straight.

1. Turn the belt sander On and check where the sanding belt (A) Fig.8 tracks on the front wheel (B).
2. Loosen the tracking knob cap screw (C) Fig.8 using the supplied hex key.
3. Turn the tracking knob (D) clockwise to move the sanding belt to the left, or turn the tracking knob counterclockwise to move the sanding belt to the right.
4. Retighten the tracking knob cap screw (C) Fig.8.
5. Verify the adjustment, make sure the sanding belt is tracking centered on the front wheel.

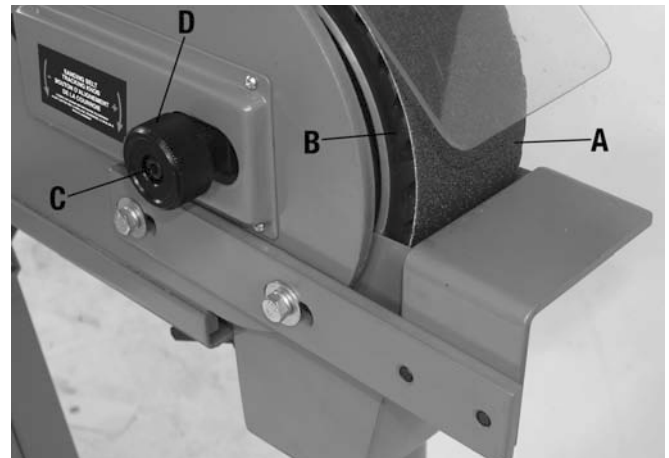

FIGURE 8

## ON/OFF switch

On the side of the motor is the On/Off switch (Fig.9). The ON button (A) Fig.9 turns the metal belt sander motor "ON".

This switch is equipped with a large STOP button (B) which turns the metal belt sander motor "OFF".

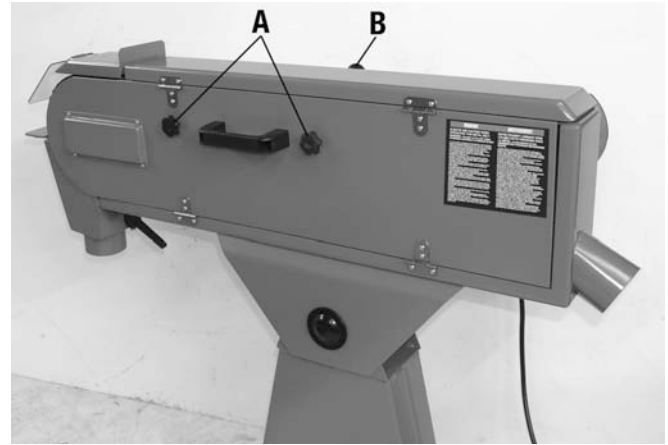

FIGURE 9

## Sanding belt replacement

The sanding belt must be checked for usage and damage on a regular basis. To replace the sanding belt:

1. Make sure the switch is Off.
2. Remove the two rear cover lock knobs (A) Fig.10.
3. Pivot the sanding belt guard (B) upwards and lower the entire belt guard and rear cover assembly as shown in Fig.11.
4. Loosen the sanding belt tension by pulling out the sanding belt tension lever (A) Fig.11.
5. Once the tension is released on the sanding belt, slide the belt off the rear and front wheels and replace it with a new one. Make sure the directional arrow on the inside of the sanding belt is facing the correct direction, refer to the directional arrow label on top of the work stop.
6. Push the tension lever back to its original position to tension the sanding belt.
7. Close the rear cover and secure it in place using the two lock knobs removed previously. Lower the sanding belt guard.
8. Once the installation of the new sanding belt is finished, check the sanding belt tracking to ensure the sanding belt is tracking properly.



**FIGURE 10**



**FIGURE 11**

## Cleaning maintenance

Regularly clean the sander parts to keep them in optimal condition. Excessive dust in the motor could cause excessive heat. Every effort should be made to prevent foreign material from entering the motor. A visual inspection should be made at frequent intervals. Accumulations of dry dust can usually be blown out to prevent the interference with normal motor ventilation. To remove dust, blow off motor with a low pressure air hose.

The operator performing this cleaning function should wear safety glasses and a filter mask. If any servicing (other than the above cleaning) becomes necessary, it should be performed by an authorized service centre.

**CAUTION:** WEARING A PARTICLE MASK/RESPIRATOR FOR PROTECTION AGAINST FINE DUST PARTICLES DURING CLEANING IS HIGHLY RECOMMENDED.

Problem	Probable cause	Probable solution
Motor will not start.	<ol style="list-style-type: none"> <li>1. Power cord unplugged or damaged.</li> <li>2. Overload- reset has tripped.</li> </ol>	<ol style="list-style-type: none"> <li>1. Plug power cord or replace it.</li> <li>2. Allow motor to cool down, press reset button.</li> </ol>
Belt does not come up to speed.	<ol style="list-style-type: none"> <li>1. Improper voltage.</li> <li>2. Low current.</li> <li>3. Extension cord gauge is to light or too long.</li> </ol>	<ol style="list-style-type: none"> <li>1. Connect to 220V-240V, single phase circuit.</li> <li>2. Contact electrician for troubleshooting.</li> <li>3. Use adequate size and length extension cord.</li> </ol>
Machine vibrates excessively.	<ol style="list-style-type: none"> <li>1. Uneven floor.</li> <li>2. Motor mounts are loose.</li> <li>3. Belt tension spring is worn or broken.</li> </ol>	<ol style="list-style-type: none"> <li>1. Place machine on even floor.</li> <li>2. Tighten all motor mount bolts.</li> <li>3. Replace the tension spring.</li> </ol>