

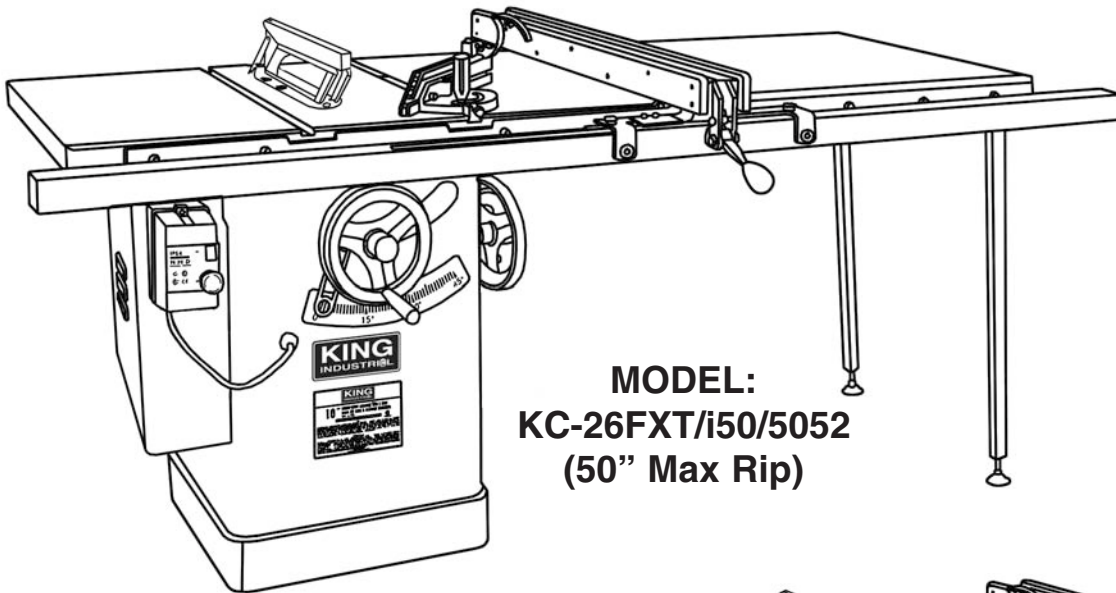

# 10" EXTREME CABINET TABLE SAWS WITH RIVING KNIFE

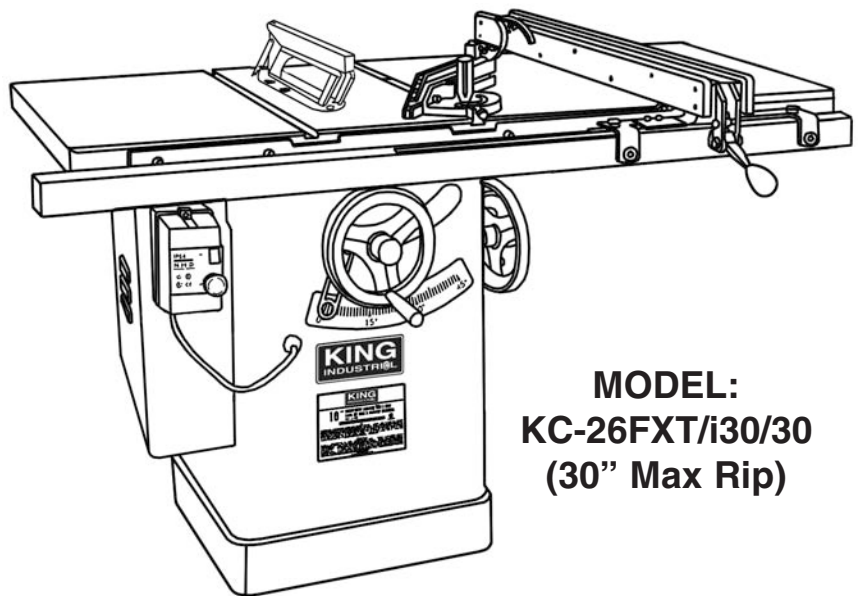

MODEL:  
KC-26FXT/i50/5052  
(50" Max Rip)



MODEL:  
KC-26FXT/i30/30  
(30" Max Rip)

Left Tilt

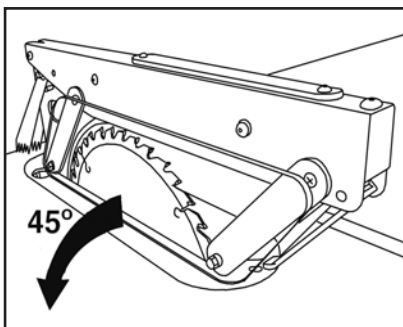

# INSTRUCTION MANUAL



## WARRANTY INFORMATION

**2-YEAR  
LIMITED WARRANTY  
FOR THIS 10" CABINET SAW**

**KING CANADA TOOLS  
OFFERS A 2-YEAR LIMITED WARRANTY  
FOR INDUSTRIAL USE.**

### **PROOF OF PURCHASE**

Please keep your dated proof of purchase for warranty and servicing purposes.

### **REPLACEMENT PARTS**

Replacement parts for this product are available at our authorized King Canada service centers across Canada.

### **LIMITED TOOL WARRANTY**

King Canada makes every effort to ensure that this product meets high quality and durability standards. King Canada warrants to the original retail consumer a 2-year limited warranty as of the date the product was purchased at retail and that each product is free from defects in materials. Warranty does not apply to defects due directly or indirectly to misuse, abuse, normal wear and tear, negligence or accidents, repairs done by an unauthorized service center, alterations and lack of maintenance. King Canada shall in no event be liable for death, injuries to persons or property or for incidental, special or consequential damages arising from the use of our products.

To take advantage of this limited warranty, return the product at your expense together with your dated proof of purchase to an authorized King Canada service center. Contact your retailer or visit our web site at [www.kingcanada.com](http://www.kingcanada.com) for an updated listing of our authorized service centers. In cooperation with our authorized serviced center, King Canada will either repair or replace the product if any part or parts covered under this warranty which examination proves to be defective in workmanship or material during the warranty period.

### **NOTE TO USER**

This instruction manual is meant to serve as a guide only. Specifications and references are subject to change without prior notice.

**KING CANADA INC. DORVAL, QUÉBEC, CANADA H9P 2Y4**

**[www.kingcanada.com](http://www.kingcanada.com)**

# GENERAL SAFETY INSTRUCTIONS FOR POWER TOOLS



## 1. KNOW YOUR TOOL

Read and understand the owners manual and labels affixed to the tool. Learn its application and limitations as well as its specific potential hazards.

## 2. GROUND THE TOOL.

This tool is equipped with an approved 3-conductor cord and a 3-prong grounding type plug to fit the proper grounding type receptacle. The green conductor in the cord is the grounding wire. **NEVER** connect the green wire to a live terminal.

## 3. KEEP GUARDS IN PLACE.

Keep in good working order, properly adjusted and aligned.

## 4. REMOVE ADJUSTING KEYS AND WRENCHES.

Form habit of checking to see that keys and adjusting wrenches are removed from tool before turning it on.

## 5. KEEP WORK AREA CLEAN.

Cluttered areas and benches invite accidents. Make sure the floor is clean and not slippery due to wax and sawdust build-up.

## 6. AVOID DANGEROUS ENVIRONMENT.

Don't use power tools in damp or wet locations or expose them to rain. Keep work area well lit and provide adequate surrounding work space.

## 7. KEEP CHILDREN AWAY.

All visitors should be kept a safe distance from work area.

## 8. MAKE WORKSHOP CHILD-PROOF.

-with padlocks, master switches or by removing starter keys.

## 9. USE PROPER SPEED.

A tool will do a better and safer job when operated at the proper speed.

## 10. USE RIGHT TOOL.

Don't force the tool or the attachment to do a job for which it was not designed.

## 11. WEAR PROPER APPAREL.

Do not wear loose clothing, gloves, neckties or jewelry (rings,

watch) because they could get caught in moving parts. Non-slip footwear is recommended. Wear protective hair covering to contain long hair. Roll up long sleeves above the elbows.

## 12. ALWAYS WEAR SAFETY GLASSES.

Always wear safety glasses (ANSI Z87.1). Everyday eyeglasses only have impact resistant lenses, they are **NOT** safety glasses. Also use a face or dust mask if cutting operation is dusty.

## 13. DON'T OVERREACH.

Keep proper footing and balance at all times.

## 14. MAINTAIN TOOL WITH CARE.

Keep tools sharp and clean for best and safest performance. Follow instructions for lubricating and changing accessories.

## 15. DISCONNECT TOOLS.

Before servicing, when changing accessories or attachments.

## 16. AVOID ACCIDENTAL STARTING.

Make sure the switch is in the "OFF" position before plugging in.

## 17. USE RECOMMENDED ACCESSORIES.

Consult the manual for recommended accessories. Follow the instructions that accompany the accessories. The use of improper accessories may cause hazards.

## 18. NEVER STAND ON TOOL.

Serious injury could occur if the tool tips over. Do not store materials such that it is necessary to stand on the tool to reach them.

## 19. CHECK DAMAGED PARTS.

Before further use of the tool, a guard or other parts that are damaged should be carefully checked to ensure that they will operate properly and perform their intended function. Check for alignment of moving parts, breakage of parts, mounting, and any other conditions that may affect its operation. A guard or other parts that are damaged should be properly repaired or replaced.

## 20. NEVER LEAVE MACHINE RUNNING UNATTENDED.

Turn power "OFF". Don't leave any tool running until it comes to a complete stop.

## SPECIFIC SAFETY INSTRUCTIONS FOR TABLE SAWS

### 1. ALWAYS USE A GUARD.

Always use a guard, splitter and anti-kickback fingers on all "thru-sawing" operations. Thru-sawing operations are those when the blade cuts completely through the workpiece as in ripping or crosscutting.

### 2. ALWAYS HOLD THE WORK.

Always hold the work firmly against the miter gauge or fence.

### 3. ALWAYS USE A PUSH STICK.

For ripping narrow stock. Refer to ripping applications in instruction manual where push sticks are covered in detail.

### 4. NEVER.

Never perform any operations "free-hand" which means using your hands to support or guide the workpiece. Always use either the fence or the miter gauge to position and guide the workpiece.

### 5. NEVER.

Never stand or have any part of your body in line with the path of the saw blade.

### 6. NEVER REACH BEHIND.

Never reach behind or over the cutting tool with either hand for any reason.

### 7. MOVE THE RIP FENCE.

Move the rip fence out of the way when crosscutting.

### 8. WHEN CUTTING MOULDINGS.

Never run the stock between the fence and the moulding cutter-

head. Refer to moulding applications in the accessory manual for details.

### 9. DIRECTION OF FEED.

Feed work into the blade against the direction of rotation.

### 10. NEVER.

Never use the fence as a cut-off gauge when you are cross-cutting.

### 11. NEVER.

Never attempt to free a stalled saw blade without first turning the saw OFF.

### 12. PROVIDE ADEQUATE SUPPORT.

To the rear and sides of the table saw for wide or long workpieces.

### 13. AVOID KICKBACKS.

Avoid kickbacks (work thrown back towards you) by keeping the blade sharp, by keeping the rip fence parallel to the saw blade, by keeping the splitter and anti-kickback fingers and guard in place and operating, by not releasing work before it is pushed all the way past the saw blade, and by not ripping work that is twisted or warped or does not have a straight edge to guide along the fence.

### 14. AVOID AWKWARD OPERATIONS.

Avoid awkward operations and hand positions where a sudden slip could cause your hand to move into the spinning blade.



# GETTING TO KNOW YOUR 10" TABLE SAW AND SPECIFICATIONS

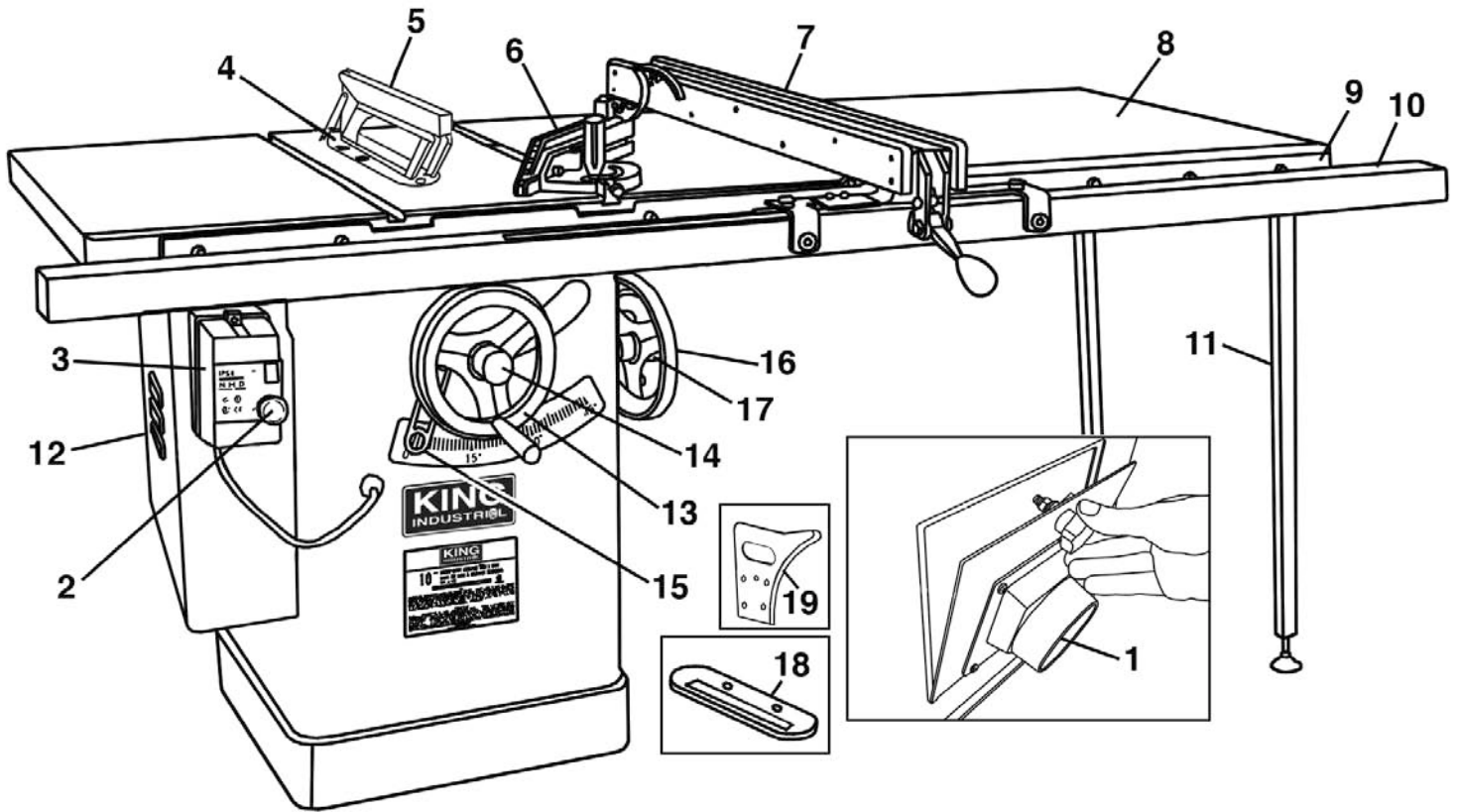

- |  |  |
|--|--|
| 1. 4" Dust chute attached to removable panel | 10. Slide tube   |
| 2. Emergency stop button                     | 11. Support legs with adjustable feet (KC-26FXT/i50/5052 only) |
| 3. Magnetic switch (thermal protection)      | 12. Motor access door  |
| 4. Table insert                              | 13. Blade raising handwheel                                    |
| 5. 2pc. blade guard with riving knife        | 14. Handwheel lock knob  |
| 6. Miter gauge                               | 15. Angle pointer and scale                                    |
| 7. T-square rip fence                        | 16. Blade tilting handwheel                                    |
| 8. Laminated extension table                 | 17. Handwheel lock knob  |
| 9. Front rail                                | 18. Dado table insert  |
|  | 19. Riving knife   |

## SPECIFICATIONS CHART

MODEL	KC-26FXT/i30/30	KC-26FXT/i50/5052
Blade diameter	10"	10"
Blade tilts	Left	Left
Depth of cut at 45°	2 3/16"	2 3/16"
Depth of cut at 90°	3 1/8"	3 1/8"
Table size with extensions	53 1/2" x 27"	74 3/4" x 27"
Diameter of arbor	5/8"	5/8"
Dado width capacity	13/16"	13/16"
Dado maximum blade diameter	8"	8"
Motor	3 HP, 4,300 RPM	3 HP, 4,300 RPM
Voltage	220V, 1 phase, 60 Hz	220V, 1 phase, 60 Hz

# ELECTRICAL REQUIREMENTS & MAGNETIC SWITCH OPERATION



## WARNING!

ALL ELECTRICAL CONNECTIONS MUST BE DONE BY A QUALIFIED ELECTRICIAN. FAILURE TO COMPLY MAY RESULT IN SERIOUS INJURY! ALL ADJUSTMENTS OR REPAIRS MUST BE DONE WITH THE MACHINE DISCONNECTED FROM THE POWER SOURCE. FAILURE TO COMPLY MAY RESULT IN SERIOUS INJURY!

## POWER SUPPLY

**WARNING:** THIS CABINET SAW CAME PRE-WIRED FOR 220V OPERATION AND MUST BE CONNECTED TO AN APPROPRIATELY GROUNDED 220V OUTLET AS SHOWN IN FIG.1.

## GROUNDING

**WARNING:** IF OUTLET IS NOT PROPERLY GROUNDED, THIS CABINET SAW CAN CAUSE ELECTRICAL SHOCK, PARTICULARLY WHEN USED IN DAMP LOCATIONS. TO AVOID SHOCK OR FIRE, IF THE POWER CORD IS WORN OR DAMAGED IN ANY WAY, HAVE IT REPLACED IMMEDIATELY.

Not all outlets are properly grounded. If you are not sure if your outlet is properly grounded, have it checked by a qualified electrician.

This cabinet saw must be grounded, if it should malfunction or break-down, grounding provides a path of least resistance for electric current, which reduces the risk of electric shock.

**WARNING:** TO MAINTAIN PROPER GROUNDING OF YOUR TABLE SAW, DO NOT REMOVE OR ALTER THE GROUNDING PRONG IN ANY MANNER.

## EXTENSION CORDS

The use of any extension cord will cause some loss of power. Use the following table to determine the minimum wire size (A.W.G-American Wire Gauge) extension cord you will need. Use only 3-wire extension cords which have 3-prong grounding type plugs and 3-hole receptacles which accept the tool's plug.

For circuits that are further away from the electrical circuit box, the wire size must be increased proportionately in order to deliver ample voltage to the cabinet saw motor. Refer to Fig.2 for wire length and size.

## MAGNETIC SAFETY SWITCH OPERATION

The magnetic safety switch as shown in Fig.3 needs to be installed to underside of the front rail, see assembly section in this manual for further instructions.

Do not turn the cabinet saw on until all assembly and adjustment instructions have been done.

To start the cabinet saw, press the green start button (A) Fig.3 and to stop the cabinet saw, press the red emergency stop button (B).

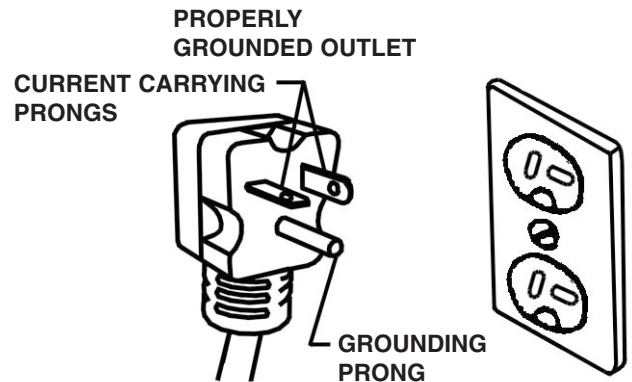

FIGURE 1

<u>LENGTH OF EXTENSION CORD</u>	<u>WIRE SIZES REQUIRED (AMERICAN WIRE GAUGE)</u> <u>220V LINES ONLY</u>
0-25 FEET	NO.12
26-50 FEET	NO.12
51-100 FEET	NO.10

FIGURE 2

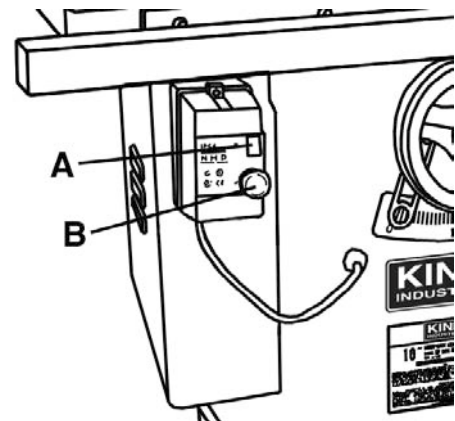

FIGURE 3

## DISASSEMBLING MOTOR BRACKET

For shipping purposes, a motor bracket (A) Fig.4 is bolted to the cabinet and attached to the motor mount. This motor bracket must be removed before assembling, adjusting or operating this cabinet saw. You should keep this motor bracket in case you plan on shipping your cabinet saw.

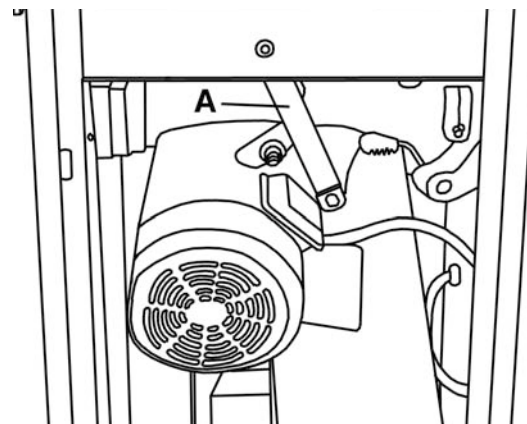

FIGURE 4

## INSTALLING MOTOR ACCESS DOOR

To prevent air born saw dust, the motor access door (A) Fig.5 should be installed to the cabinet. Slide the motor access door hinge pins (B) into the hinge supports in the cabinet. Swing and close the access door and lock it into place using the supplied lock knob (C).

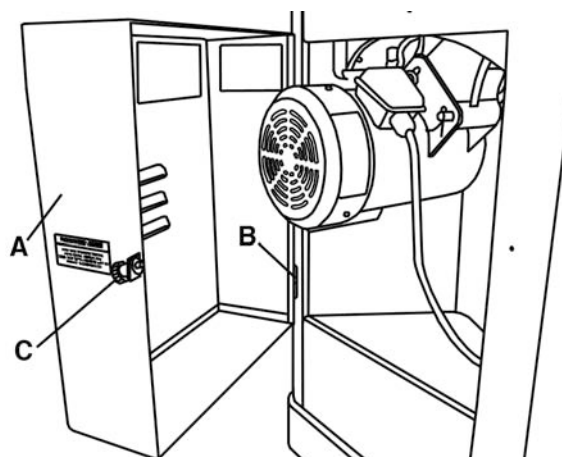

FIGURE 5

## ASSEMBLING EXTENSION WINGS

Important Note: There is a right and a left side extension wing, each extension wing has a beveled edge, this beveled edge must be positioned towards the front of the saw.

Fasten each extension wing to the table using 3 cap screws, spring washers and washer. To allow adjustment, do not fully tighten the cap screws. Align the beveled edge of each extension wing with the beveled edge of the table.

Using a straight edge, level the extension wings to the table surface as shown in Fig.6. Verify the adjustments, once the extension table is flush with the front and top of the table, tighten the cap screws.

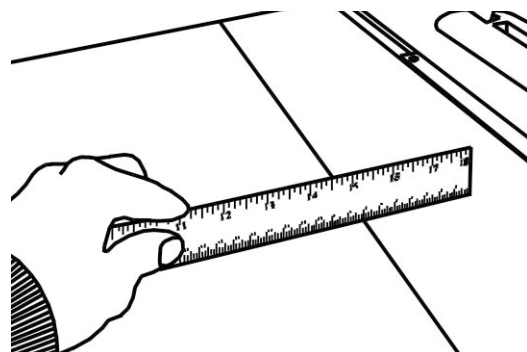

FIGURE 6

## ASSEMBLING HANDWHEELS

Position a key into the keyway of the shaft, align the keyway of the handwheel (A) Fig.7 and slide it onto the shaft. Tighten the set screw on the handwheel hub to secure it in place. Insert the center lock knob (B) into the center hole in the shaft and tighten in a clockwise direction. Then thread the handwheel handle (C) into the handwheel. Repeat for the second handwheel.

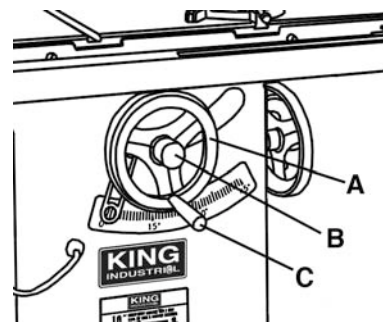

FIGURE 7

# ASSEMBLY



## INSTALLING FRONT RAIL AND TUBE ASSEMBLY

Place and align the mounting holes of the front rail and tube assembly (A) Fig.8 with the holes in the front lip of the table (C) and extension wings (D & E). Install the front rail and tube assembly to the table and extension wings using 4 hex. bolts, 8 washers, 4 spring washers and 4 hex. nuts. Before securing it in place, adjust it up or down to ensure the front rail edge is set at 3/16" below the beveled edge of the table and extension wings. Once adjusted, tighten all 4 bolts.

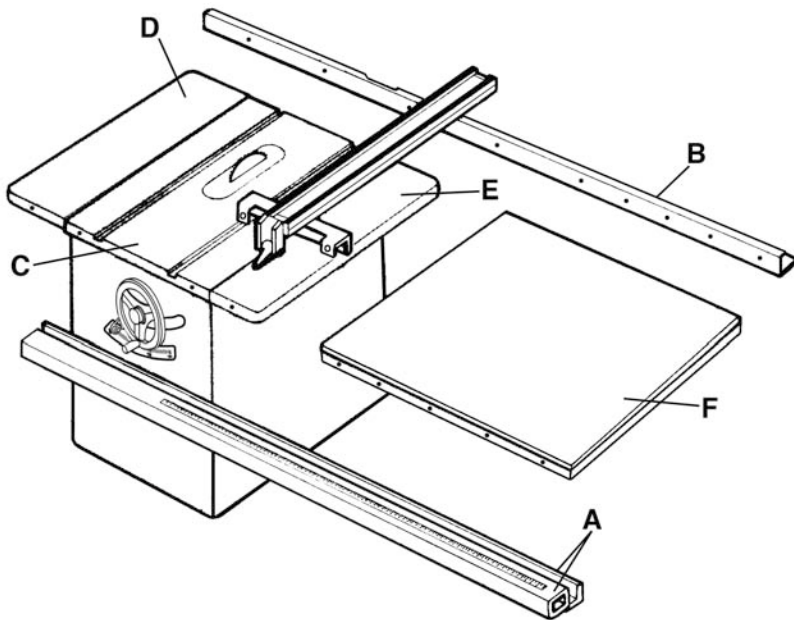

FIGURE 8

## INSTALLING REAR RAIL

Place and align the mounting holes of the rear rail (B) Fig.8 with the holes in the rear lip of the table (C) and extension wings (D & E). Install the rear rail to the table using 2 hex. bolts and 2 washers. Then 2 use hex. bolts, 4 washers, 2 spring washers and 2 hex. nuts to fix the rear rail to the extension wings. Before securing it in place, adjust it up or down to ensure the rear rail edge is set flush with the lowest edge of the miter gauge slot (to allow free movement of the miter gauge). Once adjusted, tighten all 4 bolts.

## INSTALLING LAMINATED EXTENSION TABLE

Once both rails are installed, place the laminated extension table (F) Fig.8 between the front and rear rails. Fix it in place using hex. bolts, washers, spring washers and hex. nuts. Before securing it in place, adjust it up or down to ensure the top of the laminated extension table is set flush with the top of the right side extension wing (E). Once adjusted, tighten all bolts.

## INSTALLING MEASURING TAPE

Only proceed with this step once the rip fence system has been adjusted and that the fence is perfectly parallel with the saw blade. See "Fence Adjustments". Slide the fence against the saw blade. Place the measuring tape on the tube (A) Fig.8 under the pointer window (A) Fig.9. The pointer window contains 2 small red lines which represent the thickness of the blade kerf, line up the zero mark of the measuring tape underneath the red line on the left side. Make sure the measuring tape is positioned perfectly parallel to the tube and that the measurements are clearly visible. Remove the fence. Peel away a small portion at a time of the measuring tape backing and carefully install. We suggest taking your time during this installation, if a mistake is made and the zero mark does not align perfectly, loosen the pointer window screws (B), reposition the pointer window in the correct position and retighten the screws.

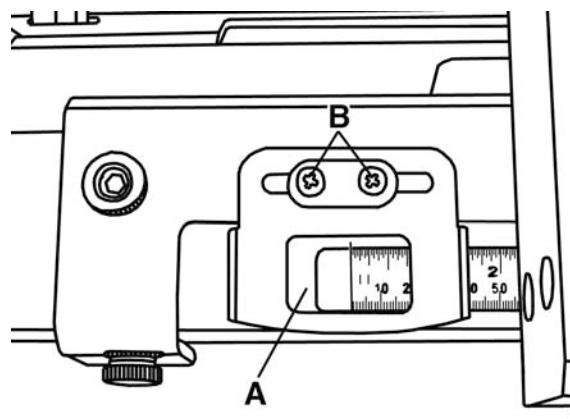

FIGURE 9

## INSTALLING SUPPORT LEGS FOR LAMINATED EXTENSION TABLE (KC-26FXT/I50/5052 ONLY)

Fasten the 2 support legs to the inner edge of the laminated extension table using 4 hex. bolts, 8 washers, 4 spring washers and 4 hex. nuts. Refer to the parts diagram for assembly.

Once installed, the adjustment feet must be adjusted properly to offer adequate support. Turn the adjustment feet until they both bottom out against the floor and tighten the upper hex. nut against each support leg to secure them in place.

## INSTALLING MAGNETIC SWITCH TO FRONT RAIL

The magnetic safety switch (A) Fig.10 comes attached to a mounting bracket (B), mount the mounting bracket to the underneath the left end of the front rail (C) using 2 hex. bolts and washers.

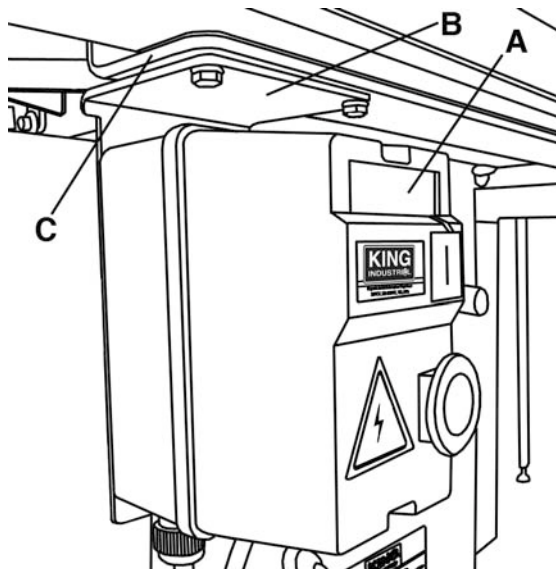

FIGURE 10

## INSTALLING / CHANGING BLADE

1. **Make sure the cabinet saw is Off and the power cord is disconnected.**
2. If you are replacing a blade, raise the saw blade to its maximum height and lock the saw at 0 degrees. Remove the table insert.
3. Jam a large piece of scrap wood into the blade teeth at the front. See Fig.11.
4. Place the blade wrench (A) Fig.11 over the arbor nut (B) and pull the wrench toward you (counterclockwise to loosen). Remove the arbor nut, flange (C) and saw blade (D).
5. Place the new or different blade on the arbor shaft making certain the teeth point down towards the front of the saw. Reposition the flange and the arbor nut.
6. Place the scrap wood in the blade's teeth in the rear. Hold carefully so if it slips or the blade turns, your hand will not contact the blade.
7. Using the wrench provided, securely tighten the arbor nut by pushing the wrench away from you (clockwise to tighten). Remove the wrench and reposition the table insert.

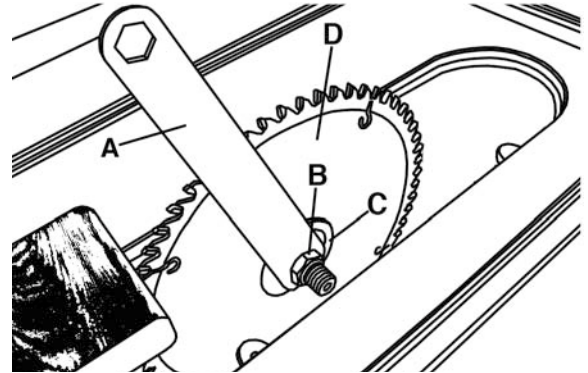

FIGURE 11

## ADJUSTING TABLE INSERT

A table insert (A) Fig.12 gets placed in the opening in the saw table and should be perfectly flush with the surface of the saw table. To adjust the table insert, place a straight edge over the table insert and the table. Turn the 4 adjusting set screws (B) in the insert, turn them in or out until all 4 corners of the insert are flush with the table top.

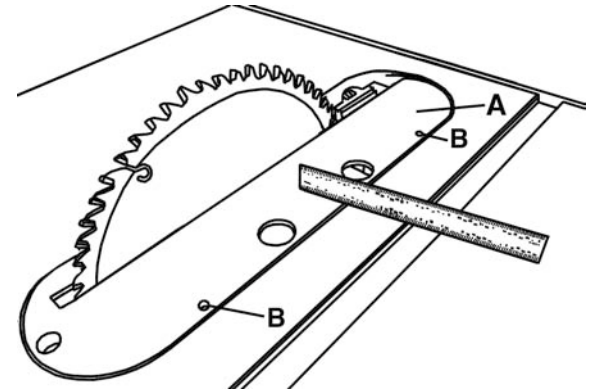

FIGURE 12

## ASSEMBLING BLADE GUARD/RIVING KNIFE

**WARNING! NEVER OPERATE SAW WITHOUT BLADE GUARD OR RIVING KNIFE IN THE PROPER OPERATING POSITION. FAILURE TO DO THIS MAY CAUSE SERIOUS INJURY!**

**Through-cut operations-** For all through-cut operations, the blade guard with splitter (A) Fig.13 must be installed.

Install the blade guard splitter (A) Fig.13 in between the mounting plates below the table insert. Push blade guard splitter all the way down, then pull the locking pin wheel (B) away from the blade, push blade guard splitter further down in between the mounting plates until the locking pin engages the splitter. Give the splitter and upward tug to make sure that it is properly locked. The clearance between the blade and the splitter should be between 1/8" to 5/16" (3-8mm).

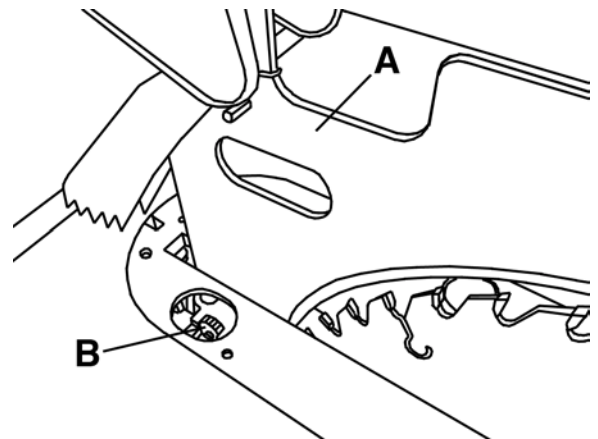

FIGURE 13

**Non through-cut operations-** For non through-cut operations with a 10" blade, the riving knife (A) Fig.14 must be installed.

The riving knife gets installed the same way as the blade guard splitter, see instructions above. For safety reasons, the highest point of the riving knife (A) Fig.14 should never exceed the highest point of the blade teeth, generally 1/8" to 3/16" (1-5mm). See adjustments for more information.

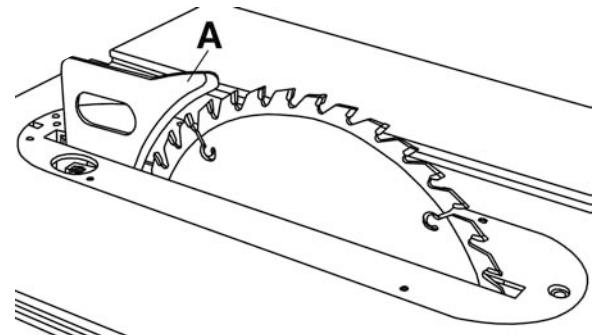

FIGURE 14

## WARNING!

SOME CUTTING OPERATIONS (DADO BLADE, MOLDING CUTTERHEAD) WON'T ALLOW USE OF THE BLADE GUARD OR RIVING KNIFE. USE EXTREME CAUTION DURING THESE OPERATIONS AS THE BLADE OR CUTTERHEAD WILL BE EXPOSED AND COULD CAUSE SERIOUS INJURY.



# ADJUSTMENTS



## POSITIONING AND ADJUSTING MITER GAUGE

The miter gauge shown in Fig.15 normally gets positioned on the left side of the blade by sliding the miter gauge bar (A) into the table T-slot. It is important to make sure there is no side to side play, to adjust, loosen cap screws which hold adjust guide blocks (B), tighten the set screws mounted in the adjust guide blocks, retighten the 2 cap screws and test the adjustment, adjust as necessary.

To operate the miter gauge, loosen lock knob (C) Fig.15, pull out the spring loaded positive stop knob (D) and pivot the miter gauge body (E) to the desired angle, release the positive stop knob once you have reached your desired angle and tighten lock knob (C). If you desire a 0° or 45° setting to the right or left, it is not necessary to pull out the positive stop knob, simply turn the miter gauge body until it snaps into one of the positive stop positions.

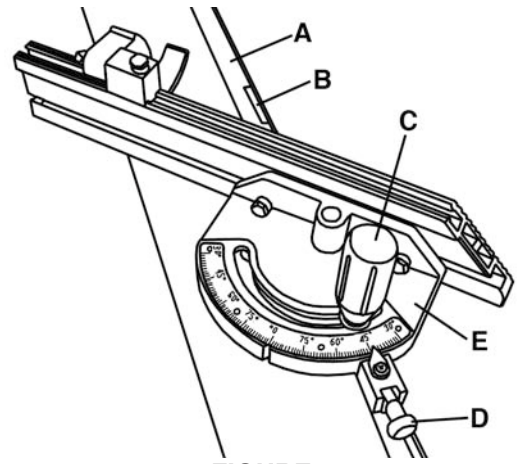

FIGURE 15

## MITER GAUGE FLIP STOP

This miter gauge comes with a flip work stop (A) Fig.16 which get installed in the T-slot on top of the miter gauge fence (B). To position the flip work stop, loosen hex. bolt (C), move the flip work stop in the desired position and retighten hex. bolt. When the flip work stop is not required, simply flip it upwards or it can be removed completely.

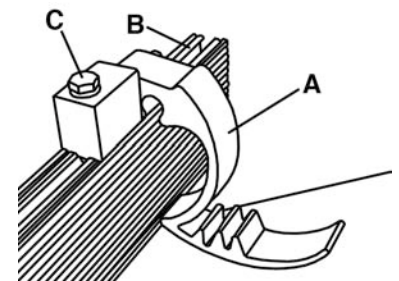

FIGURE 16

## BLADE RAISING AND TILTING MECHANISM

To raise or lower the blade, loosen lock knob (A) Fig.17. and turn the raising handwheel (B). When desired height is obtained, retighten lock knob. The blade should be raised 1/8" to 1/4" above the top surface of the material being cut. With hollow ground blades the blade should be raised to the maximum to provide chip clearance.

To tilt the saw blade, loosen lock knob (C) and turn tilting handwheel (D). When desired angle is obtained, retighten lock knob.

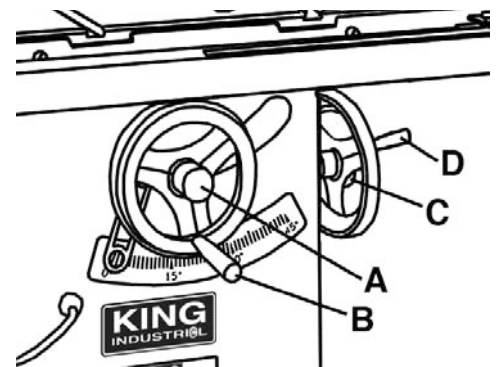

FIGURE 17

## ADJUSTING RIP FENCE

The rip fence must be perfectly aligned with the table T-slot, to verify this, align the edge of the rip fence with the table T-slot and lower the locking lever (A) Fig. 18 to lock in into place. Check to see if the edge of the rip fence and the table T-slot are parallel. If they are not parallel, unlock the rip fence and turn it upside down. Adjust the set screws (A) Fig.19 in or out, verify your adjustment, repeat if necessary.

The lock lever pressure can be adjusted by loosening the front lock nuts (B) Fig.18 and adjusting the set screws (C) the same amount, make sure the fence remains parallel with the table T-slot. Retighten lock nuts. To set the fence perpendicular to the table, place a square on the table and against the side of the fence, loosen the top lock nuts (D) and adjust the set screws (E) until the fence is perpendicular. Retighten lock nuts. The pointer window (F) Fig.18 position can be adjusted if needed, loosen pan head screws (G), reposition the pointer window and retighten pan head screws.

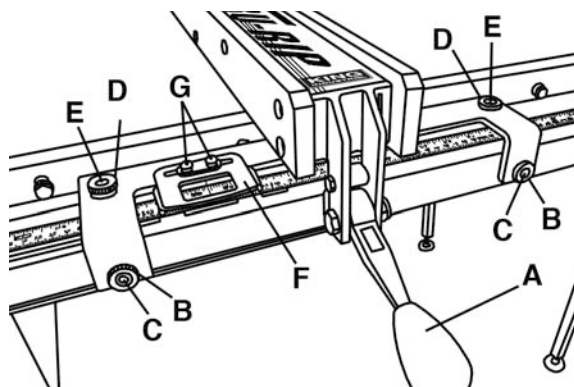

FIGURE 18

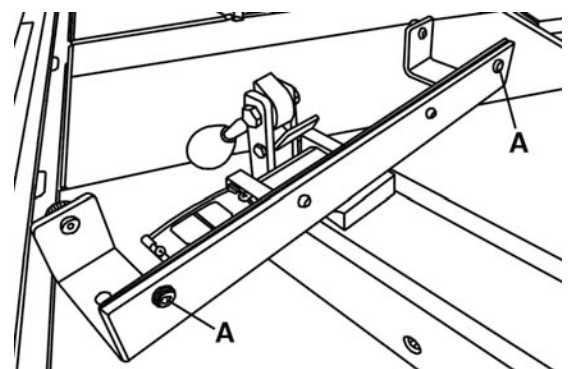

FIGURE 19



## ADJUSTMENTS

### ALIGNING TABLE T-SLOT PARALLEL WITH BLADE

The table T-slot must be aligned parallel with the blade. Using a combination square (A) Fig.20, measure the distance from the back edge of the blade to the table T-slot. Pivot blade forward 180° and remeasure the distance using the exact same point on the blade. The difference between both measurements must be equal to or less than 1/64".

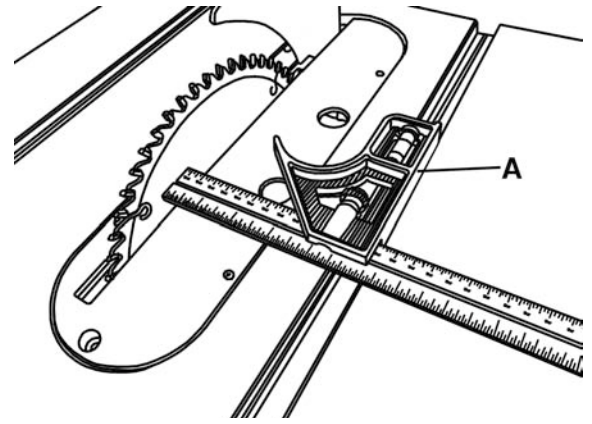

FIGURE 20

If an adjustment is necessary, loosen the four cap screws (A) Fig.21 which fix the table top to the cabinet, make the needed adjustment to the table top position until both measurements are equal or less than 1/64" and retighten the four cap screws (A).

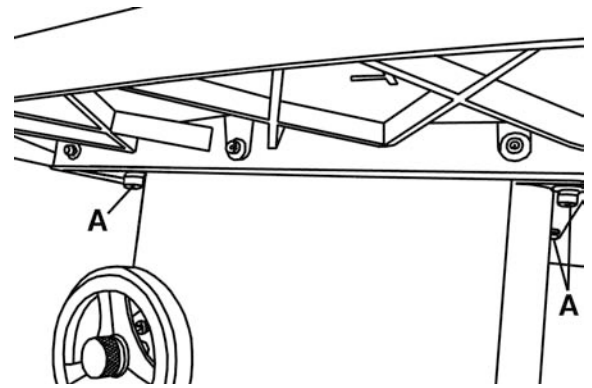

FIGURE 21

### ALIGNING BLADE GUARD SPLITTER OR RIVING KNIFE WITH BLADE

The blade guard splitter and/or riving knife must be aligned with the blade. If not properly aligned, the splitter/riving knife will force the workpiece sideways during the cut, increasing risk of kickback.

Place a straightedge against the blade and the splitter or riving knife and check for parallelism. If an adjustment is needed, the mounting position can be adjusted into alignment with the blade using the adjustment set screws (A) Fig.22.

1. Disconnect saw from power source.
2. Remove the table insert.
3. Loosen the upper and lower cap screws (B) Fig.22, then adjust the 4 set screws in or out until the alignment is perfectly parallel.
4. Reinstall the table insert.

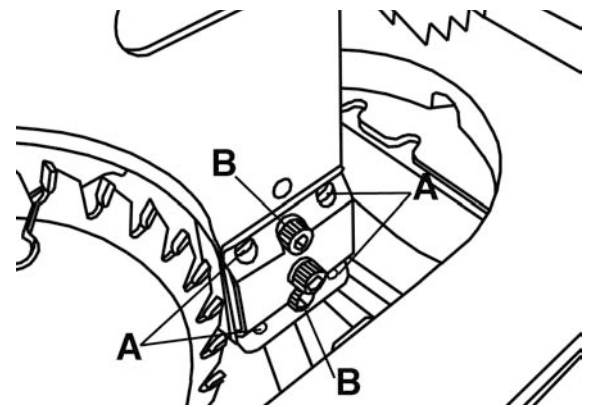

FIGURE 22

For safety reasons, the highest point of the riving knife (A) Fig.23 should never exceed the highest point of the blade teeth, generally 1/8" to 3/16" (1-5mm).

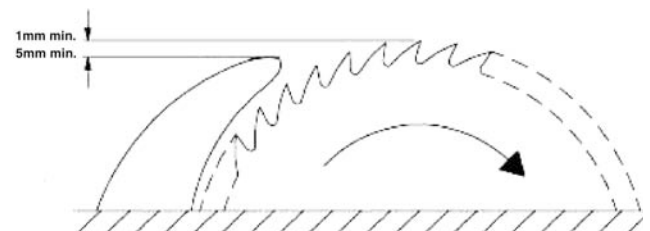

FIGURE 23

# ADJUSTMENTS & OPERATION



## ADJUSTING 45 AND 90 DEGREE POSITIVE STOPS

The blade tilting mechanism of your saw is equipped with a positive stop at 45 and 90 degrees. To check and adjust these positive stops, proceed as follows:

1. Raise the saw blade to its maximum height.
2. Set the blade at 90 degrees to the table by turning the blade tilting handwheel counterclockwise as far as it will go.
3. Place a square on the table and check to see if the blade is at a perfect 90 degree angle to the table.
4. If the blade is not at 90 degrees loosen lock nut (A) Fig. 24 and turn stop bolt (B) in or out. The stop bolt (B) should stop against the front trunnion bracket when the blade is at 90 degrees to the table. Recheck and adjust further if necessary. Retighten lock nut (A).
5. If the 45 degree positive stop is not set properly, turn the same handwheel clockwise as far as it will go and follow the same procedure using lock nut (A) Fig.25 and stop bolt (B). The stop bolt (B) should stop against the front trunnion bracket when the blade is at 45 degrees to the table. Recheck and adjust further if necessary. Retighten lock nut (A).

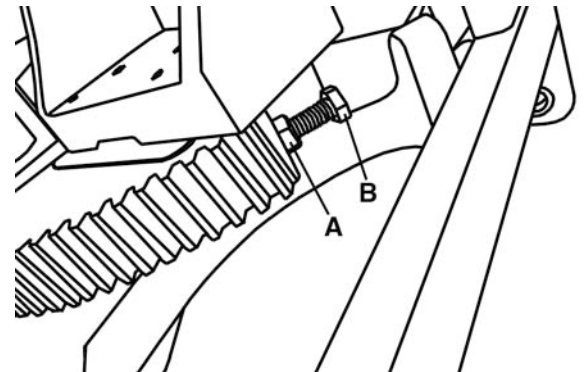

FIGURE 24

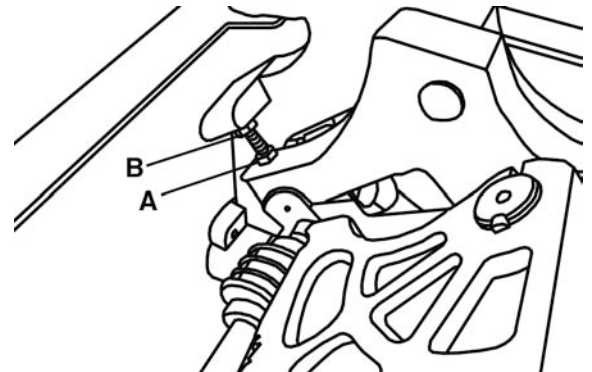

FIGURE 25

## SAFETY PRECAUTIONS BEFORE OPERATION

The operation of power tools involves a certain amount of hazard for the operator. Before attempting regular work we recommend you get the feel of operations using scrap lumber to check settings. Read entire instructions before you start to cut workpiece. Always pay attention to safety precautions to avoid personal injury.

## OPERATION

Plain sawing includes ripping and crosscutting, plus a few other standard operations of a fundamental nature. The following methods feature safety. As with all power tools there is a certain amount of hazard involved with the operation and use of the tool. Using the tool with the respect and caution demanded as far as safety precautions are concerned will considerably lessen the possibility of personal injury. However, if normal safety precautions are overlooked or completely ignored, personal injury to the operator can develop. It is good practice to make trial cuts using scrap material when setting up you saw for operation.

## CROSSCUTTING

Crosscutting requires the use of the miter gauge to position and guide the work. Place the work against the miter gauge and advance both the miter gauge and work toward the saw blade, as shown in Fig.26. The miter gauge may be used in either table slot, however, most operators prefer the left groove for average work. When bevel cutting (blade tilted), use the table groove that does not cause interference of your hand or miter gauge with the saw blade guard.

Start the cut slowly and hold the work firmly against the miter gauge and the table. One of the rules in running a saw is that you never hang onto or touch a free piece of work. Hold the supported piece, not the free piece that is cut off. The feed in crosscutting continues until the work is cut in two, then the miter gauge and work are pulled back to the starting point. Before pulling the work back it is good practice to give the work a little sideways shift to move the work slightly away from the saw blade.

Never pick up any short length of free work from the table while the saw is running.

A smart operator never touches a cut-off piece unless it is at least a foot long. Never use the fence as a cut-off gauge when crosscutting. Never use the miter gauge in combination with the rip fence.

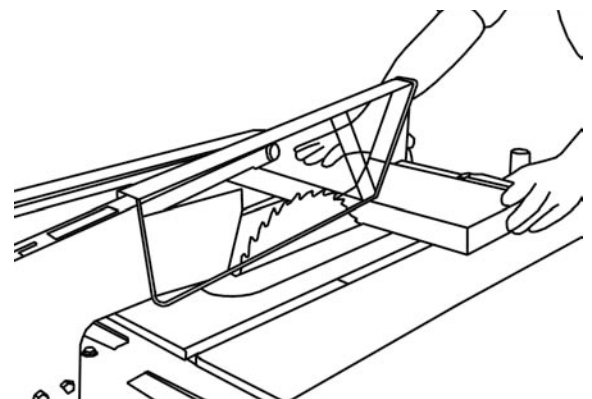

FIGURE 26



# OPERATION

## RIPPING

Ripping is the operation of making a lengthwise cut through a board, as shown in Fig.27, and the rip fence is used to position and guide the work. One edge of the work rides against the rip fence while the flat side of the board rest on the table. Since the work is pushed along the fence, it must have a straight edge and make solid contact with the table. The saw guard must be used. The guard has anti-kickback fingers and a splitter to prevent the saw kerf from closing.

Start the motor and advance the work holding it down and against the fence. Never, stand in the line of the saw cut when ripping. Hold the work with both hands and push it along the fence and into the saw blade as shown in Fig.27. The work can then be fed through the saw blade with one or two hands.

When this is done the work will either stay on the table, tilt up slightly and be caught by the rear end of the guard or slide off the table to the floor. Alternately, the feed can continue to the end of the table, after which the work is lifted and brought back along the outside edge of the fence. The waste stock remains on the table and is not touched with the hands until the saw is stopped unless it is a large piece allowing safe removal.

## USING DADO BLADE SET (OPTIONAL) AND DADO INSERT

Dadoing is cutting a rabbet or a wide groove into the work. Most dado head sets are made up of two outside blades and four or five inside cutters, as shown in Fig. 28. Various combination of saws and cutters are used to cut grooves from 1/8" to 13/16" for use in shelving, making joints, tenoning, grooving, ect. The cutters are heavily swaged and must be arranged so that this heavy portion falls in the gullet of the outside blades, as shown in Fig. 29. The saw and cutter overlap is shown in Fig.29 (A) being the outside blade, (B) and inside cutter, and (C) a paper washer which can be used as needed to control the exact width of groove. A 1/4" groove is cut by using the two outside blades. The teeth of the blades should be positioned so that the raker on one saw is beside the cutting teeth on the other saw.

The dado head set is assembled to the saw arbor in the same manner as the saw blade. The guard splitter and anti-kickback finger assembly can not be used when dadoing operations and must be removed from the saw. The included dado head table insert must be used in place of the standard table insert.

**NEVER USE THE DADO HEAD IN A BEVEL POSITION UNLESS YOU MAKE YOUR OWN DADO INSERT!**

**ALWAYS INSTALL BLADE GUARD AFTER OPERATION IS COMPLETE!**

## PUSH STICK CONSTRUCTION

A push stick is not supplied with this table saw and should be used whenever possible. Fig.30 shows an illustration of how to make one yourself. It is recommended to use a good quality plywood or solid wood, 1/2" and 3/4" thick.

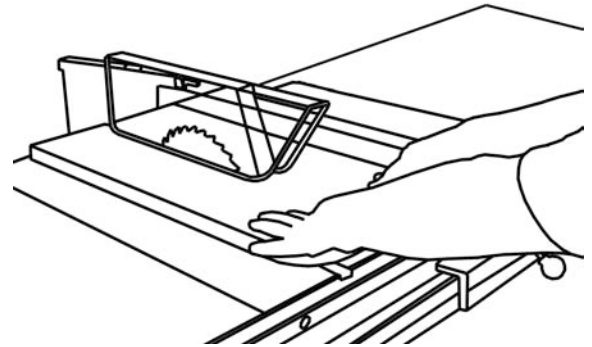

FIGURE 27

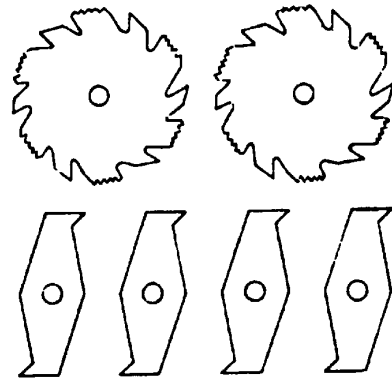

FIGURE 28

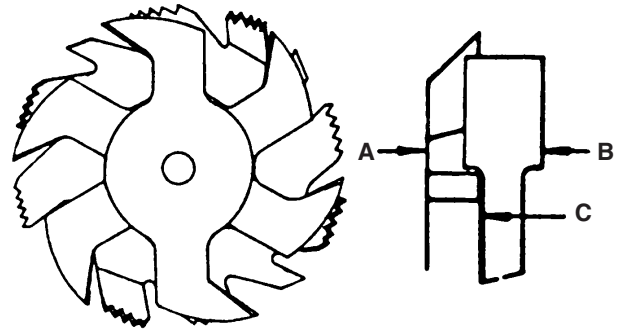

FIGURE 29

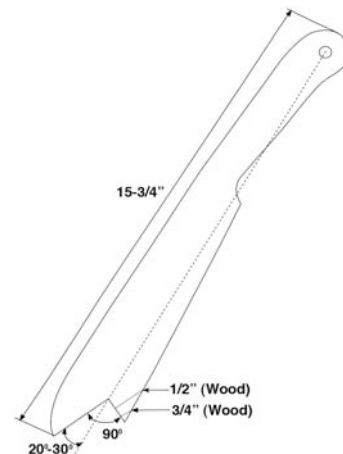

FIGURE 30

# MAINTENANCE & OPTIONAL ACCESSORIES



This table saw requires very little maintenance other than minor lubrication and cleaning. The following sections detail what will need to be done in order to assure continued operation of your saw.

## LUBRICATION

The table saw has sealed lubricated bearings in the motor housing and the arbor assembly, they will not require any additional lubrication. Use a wire brush to clean off the worm gears and trunnions and apply a white lithium grease to keep them lubricated.

## CLEANING

Keep the inside of the cabinet clear of saw dust and wood chips. Open the dust chute access door (A) Fig.31 by turning the lock knob (B) a 1/4 turn. With the table saw unplugged, vacuum out the inside of the cabinet or blow out the inside with an air hose.

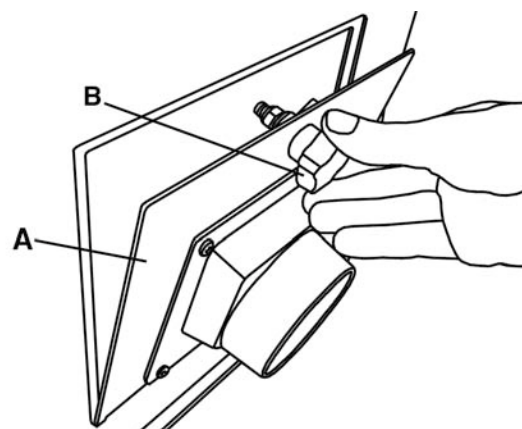

FIGURE 31

## CHANGING BELTS

**MAKE SURE THE POWER CORD IS DISCONNECTED FROM THE POWER SOURCE.**

To remove the 3 V-belts (A) Fig.32, first lower the blade to its lowest point. Loosen the large hex. nut (B) and then take the tension off of the V-belts by lifting up on the motor. Remove the V-belts from the arbor shaft and the motor pulley and replace them with new ones. Lower the motor, the weight of the motor should apply enough tension and retighten large hex. nut (B). Check the V-belt tension after the saw has been used for a few hours. Adjust as necessary.

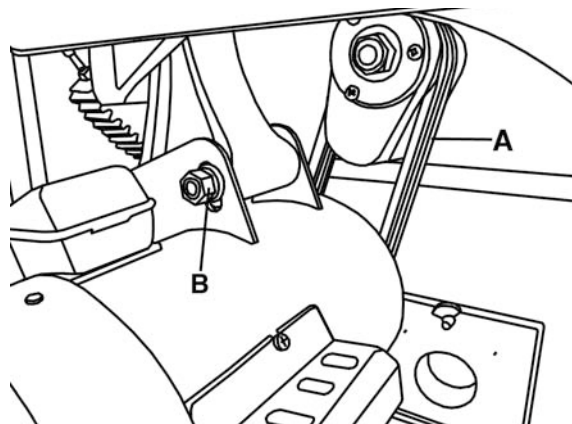

FIGURE 32

## OPTIONAL ACCESSORIES

**Router Table Attachment  
model KRT-100 (Fig.33)**

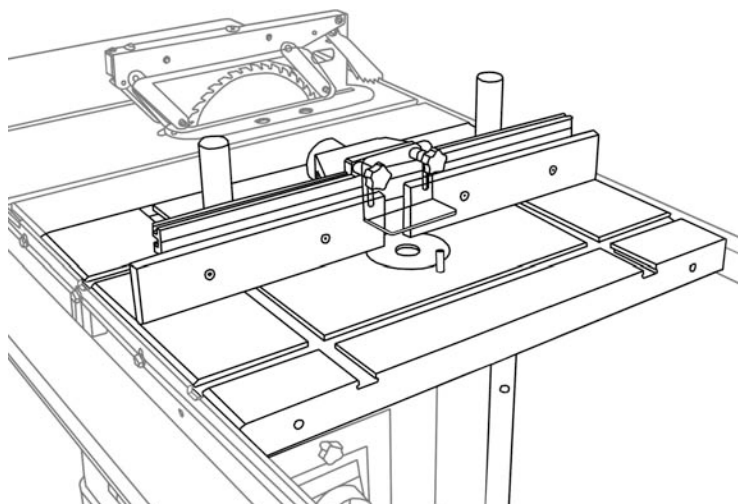

FIGURE 33

**Sliding Table Attachment  
model KST-101 (Fig.34)**

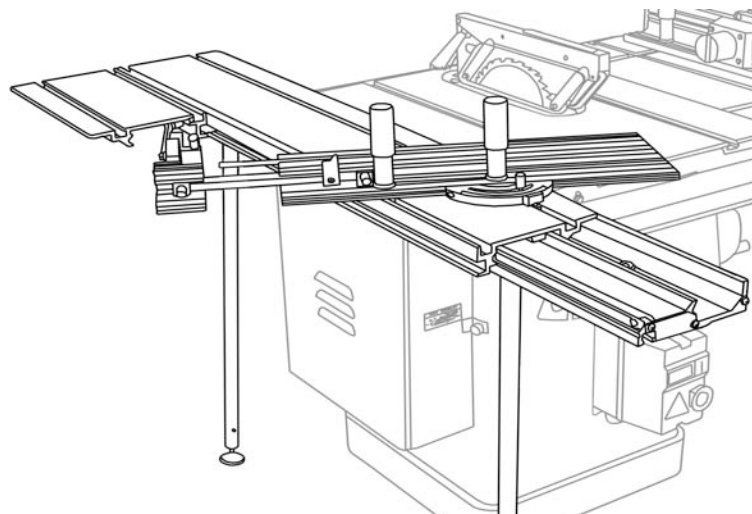

FIGURE 34

These optional accessories are designed to fit table saw model KC-26FXT and also fit most table saws having a 27" deep table.



# TROUBLESHOOTING

PROBLEM	SOLUTION
<b>SAW WILL NOT START</b> 1. Saw not plugged in. 2. Fuse blown or circuit breaker tripped. 3. Cord damaged.	1. Plug in saw. 2. Replace fuse or reset circuit breaker. 3. Have cord replaced by a certified electrician.
<b>OVERLOAD KICKS OUT FREQUENTLY</b> 1. Extension cord too light or too long. 2. Feeding stock too fast. 3. Blade in poor condition (dull, warped, gummed). 4. Blade binding due to misaligned rip fence. 5. Blade binding due to warped wood. 6. Low house current.	1. Replace with adequate size cord. 2. Feed stock more slowly. 3. Clean or replace blade. 4. Check and adjust the rip fence. See rip fence instructions. 5. Select another piece of wood. 6. Contact your electrical company.
<b>DOES NOT MAKE ACCURATE 45° AND 90° RIP CUTS</b> 1. Positive stop(s) not adjusted properly. 2. Tilt angle pointer not set properly.	1. Check blade with square and adjust positive stop. 2. Check blade with square and adjust pointer to zero.
<b>MATERIAL PINCHES BLADE WHEN RIPPING</b> 1. Rip fence not aligned with blade. 2. Warped wood.	1. Check and adjust rip fence. 2. Select another piece of wood.
<b>MATERIAL BINDS ON SPLITTER</b> 1. Splitter not aligned correctly with blade kerf.	1. Check and align splitter with blade kerf.
<b>SAW MAKES UNSATISFACTORY CUTS</b> 1. Dull blade. 2. Blade mounted backwards. 3. Gum or pitch on blade. 4. Incorrect blade for work being done. 5. Gum or pitch on table causing erratic feed.	1. Replace blade. 2. Turn blade around. 3. Remove blade and clean with turpentine and steel wool. 4. Change the blade. 5. Clean the table with turpentine and steel wool.
<b>BLADE DOES NOT COME UP TO SPEED</b> 1. Extension cord too light or too long. 2. Low house current. 3. Motor not wired for correct voltage.	1. Replace with adequate size extension cord. 2. Contact your electric company. 3. Refer to motor and /or nameplate.
<b>MACHINE VIBRATES EXCESSIVELY</b> 1. Table not mounted securely to cabinet stand. 2. Stand is on uneven floor. 3. Damaged saw blade. 4. Bad V-belt(s). 5. V-belts not tensioned properly. 6. Bent pulley. 7. Improper motor mounting. 8. Loose hardware.	1. Tighten all mounting hardware. 2. Reposition on flat level surface. 3. Replace blade. 4. Replace V-belt(s). 5. Adjust V-belt tension. 6. Replace pulley. 7. Check and adjust motor mounting. 8. Tighten all nuts, bolts and set screws.
<b>BLADE DOES NOT RAISE OR TILT FREELY</b> 1. Sawdust or dirt in raising or tilting mechanisms.	1. Brush or blow out loose dust or dirt.

## PARTS DIAGRAM & PARTS LISTS

Refer to the Parts section of the King Canada web site for the most updated parts diagram and parts list.