



10" X 18" VARIABLE SPEED SWIVEL METAL CUTTING BANDSAW

09/2013



MODELS:
KC-228S-V-2 (220V)
KC-228S-V-6 (600V)

INSTRUCTION MANUAL

COPYRIGHT © 2013 ALL RIGHTS RESERVED BY KING CANADA TOOLS INC.



WARRANTY INFORMATION

**2-YEAR
LIMITED WARRANTY
FOR THIS 10" X 18" METAL CUTTING BANDSAW**

**KING CANADA TOOLS
OFFERS A 2-YEAR LIMITED WARRANTY
FOR INDUSTRIAL USE.**

PROOF OF PURCHASE

Please keep your dated proof of purchase for warranty and servicing purposes.

REPLACEMENT PARTS

Replacement parts for this product are available at our authorized King Canada service centers across Canada.

LIMITED TOOL WARRANTY

King Canada makes every effort to ensure that this product meets high quality and durability standards. King Canada warrants to the original retail consumer a 2-year limited warranty as of the date the product was purchased at retail and that each product is free from defects in materials. Warranty does not apply to defects due directly or indirectly to misuse, abuse, normal wear and tear, negligence or accidents, repairs done by an unauthorized service center, alterations and lack of maintenance. King Canada shall in no event be liable for death, injuries to persons or property or for incidental, special or consequential damages arising from the use of our products.

To take advantage of this limited warranty, return the product at your expense together with your dated proof of purchase to an authorized King Canada service center. Contact your retailer or visit our web site at www.kingcanada.com for an updated listing of our authorized service centers. In cooperation with our authorized serviced center, King Canada will either repair or replace the product if any part or parts covered under this warranty which examination proves to be defective in workmanship or material during the warranty period.

NOTE TO USER

This instruction manual is meant to serve as a guide only. Specifications and references are subject to change without prior notice.

PARTS DIAGRAM & PARTS LISTS

Refer to the Parts section of the King Canada web site for the most updated parts diagram and parts list.

KING CANADA INC. DORVAL, QUÉBEC, CANADA H9P 2Y4

www.kingcanada.com

GENERAL & SPECIFIC SAFETY INSTRUCTIONS



VOLTAGE WARNING: Before connecting the tool to a power source (receptacle, outlet, etc.) be sure the voltage supplied is the same as that specified on the nameplate of the tool. A power source with voltage greater than that for the specified tool can result in **SERIOUS INJURY** to the user - as well as damage to the tool. If in doubt **DO NOT PLUG IN THE TOOL**. Using a power source with voltage less than the nameplate is harmful to the motor.

1. KNOW YOUR TOOL

Read and understand the owners manual and labels affixed to the tool. Learn its application and limitations as well as its specific potential hazards.

2. GROUND THE TOOL.

This tool is equipped with an approved 3-conductor cord and a 3-prong grounding type plug to fit the proper grounding type receptacle. The green conductor in the cord is the grounding wire. **NEVER** connect the green wire to a live terminal.

3. KEEP GUARDS IN PLACE.

Keep in good working order, properly adjusted and aligned.

4. REMOVE ADJUSTING KEYS AND WRENCHES.

Form habit of checking to see that keys and adjusting wrenches are removed from tool before turning it on.

5. KEEP WORK AREA CLEAN.

Cluttered areas and benches invite accidents. Make sure the floor is clean and not slippery due to wax and sawdust build-up.

6. AVOID DANGEROUS ENVIRONMENT.

Don't use power tools in damp or wet locations or expose them to rain. Keep work area well lit and provide adequate surrounding work space.

7. KEEP CHILDREN AWAY.

All visitors should be kept a safe distance from work area.

8. MAKE WORKSHOP CHILD-PROOF.

Use padlocks, master switches or remove starter keys.

9. USE PROPER SPEED.

A tool will do a better and safer job when operated at the proper speed.

10. USE RIGHT TOOL.

Don't force the tool or the attachment to do a job for which it was not designed.

11. WEAR PROPER APPAREL.

Do not wear loose clothing, gloves, neckties or jewelry (rings, watch) because they could get caught in moving parts. Non-slip footwear is recommended. Wear protective hair covering to

contain long hair. Roll up long sleeves above the elbows.

12. ALWAYS WEAR SAFETY GLASSES.

Always wear safety glasses (ANSI Z87.1). Everyday eyeglasses only have impact resistant lenses, they are **NOT** safety glasses. Also use a face or dust mask if cutting operation is dusty.

13. DON'T OVERREACH.

Keep proper footing and balance at all times.

14. MAINTAIN TOOL WITH CARE.

Keep tools sharp and clean for best and safest performance. Follow instructions for lubricating and changing accessories.

15. DISCONNECT TOOLS.

Before servicing, when changing accessories or attachments.

16. AVOID ACCIDENTAL STARTING.

Make sure the switch is in the "OFF" position before plugging in.

17. USE RECOMMENDED ACCESSORIES.

Consult the manual for recommended accessories. Follow the instructions that accompany the accessories. The use of improper accessories may cause hazards.

18. NEVER STAND ON TOOL.

Serious injury could occur if the tool tips over. Do not store materials such that it is necessary to stand on the tool to reach them.

19. CHECK DAMAGED PARTS.

Before further use of the tool, a guard or other parts that are damaged should be carefully checked to ensure that they will operate properly and perform their intended function. Check for alignment of moving parts, breakage of parts, mounting, and any other conditions that may affect its operation. A guard or other parts that are damaged should be properly repaired or replaced.

20. NEVER LEAVE MACHINE RUNNING

UNATTENDED.

Turn power "OFF". Don't leave any tool running until it comes to a complete stop.

SPECIFIC SAFETY INSTRUCTIONS

1. If you are not thoroughly familiar with the operation of bandsaws, obtain advice from your supervisor, instructor or other qualified person.

2. Adjust and position the blade guide arm before starting the cut.

3. Keep blade guide arm tight. A loose blade guide arm will affect sawing accuracy.

4. Make sure that blade tension and blade tracking are properly adjusted.

5. To prolong blade life always release blade tension at the end of each work day.

6. Make sure blade speed is set correctly for material being cut.

7. Always have stock firmly clamped in vise before starting cut.

8. Check coolant daily: Low coolant level can cause foaming and high blade temperatures. Dirty or weak coolant can clog pump, cause crooked cuts, low cutting rate and permanent blade failure. Dirty coolant can cause the growth of bacteria with ensuing skin irritation.



GETTING TO KNOW YOUR METAL CUTTING BANDSAW

WARNING: For your own safety, never connect the bandsaw to a power source until you have read and understood safety, adjustments and operational instructions.

UNPACKING AND CLEANING

Remove wooden crate around the machine, unbolt bandsaw from the crate base. Many parts are coated with rust prevention product which must be removed with a soft cloth soaked in kerosene before operation. Do not use acetone, gasoline, or lacquer thinner; these are dangerous products. It is recommended to apply a coat of paste wax to the table work surface.

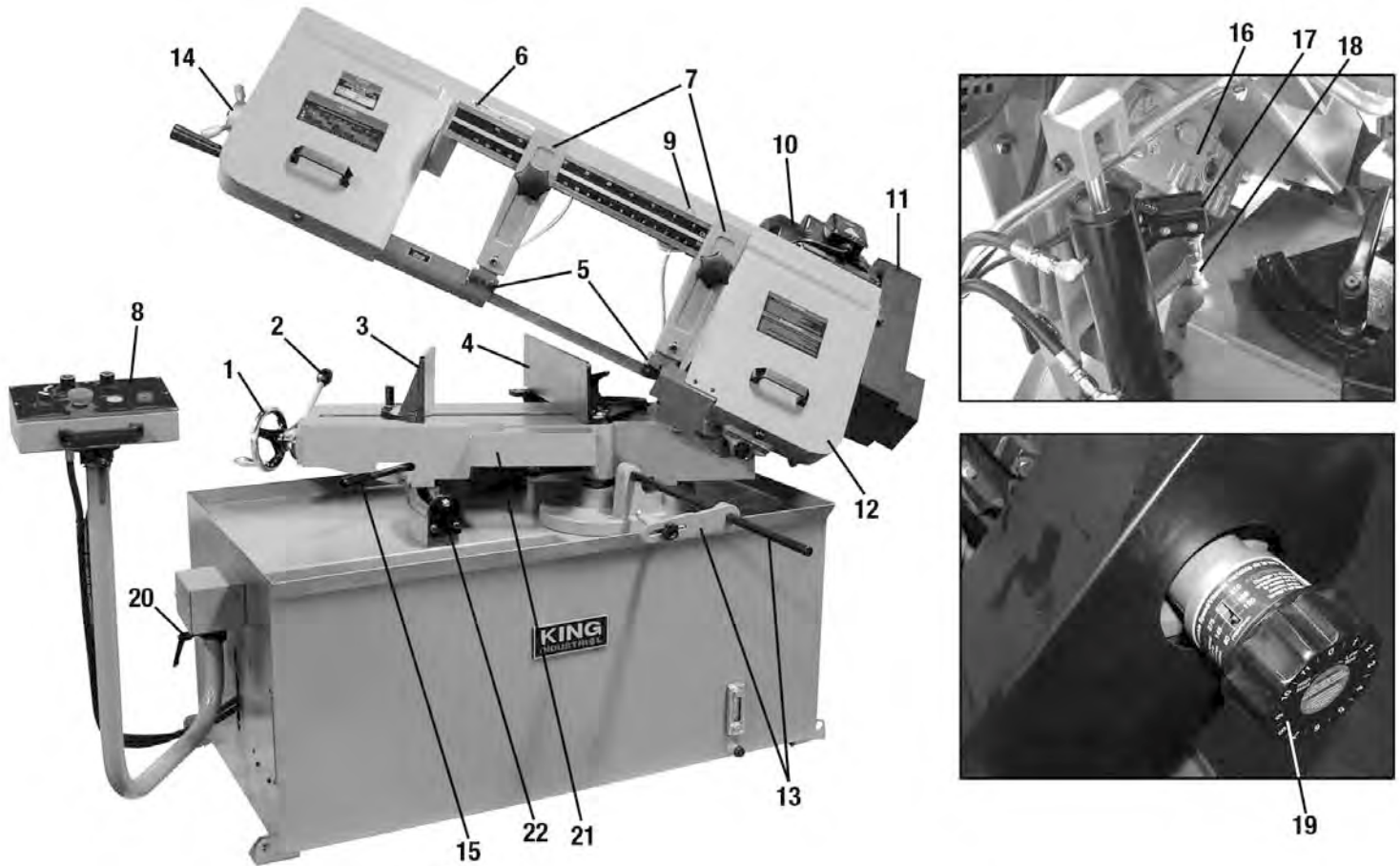

- 1-Vise handwheel.** Moves the movable vise jaw towards the workpiece.
- 2-Vise quick cam lock lever.** Quickly clamps and unclamps workpiece.
- 3-0-45° Movable quick positioning vise jaw.**
- 4-0-45° Stationary vise jaw.**
- 5-Blade guide assemblies.**
- 6-Left side coolant flow valve.**
- 7-Control arms.** Must be moved as close to the cut as possible for accurate cuts.
- 8-Control panel.** Contains the Coolant on/off, Stop button, On button, Power on light, Down feed rate dial and hydraulic cylinder on/off.
- 9-Right side coolant flow valve.**
- 10-Motor.**
- 11-Pulley cover.**
- 12-Blade wheel cover. (1 of 2)**

- 13-Work stop and work stop shaft.** Position this work stop when even length repetitive cuts are desired.
- 14-Blade tension levers.** Tightens or loosens the blade tension.
- 15-Swivel table lock lever.**
- 16-Gear box.**
- 17-Limit switch.** Once the limit switch reaches the stop bolt beneath it, the bandsaw automatically shuts off.
- 18-Stop bolt.**
- 19-Variable speed selector dial.** Increase or decrease the speed of the blade by turning the selector dial.
- 20-Control panel arm lock handle.** Position the control panel in the desired position and lock it in place using this lock handle.
- 21-Swivel table.** Pivots 0°-45°
- 22-Swivel table stop plate.**

SPECIFICATIONS AND ELECTRICAL INFORMATION



MODEL	KC-228S-V-2	KC-228S-V-6
Cutting capacity at 90°	Rect. 10" x 18" ● Diam. 10"	Rect. 10" x 18" ● Diam. 10"
Cutting capacity at 45°	Rect. 7 7/8" x 7 7/8" ● Diam. 7 7/8"	Rect. 7 7/8" x 7 7/8" ● Diam. 7 7/8"
Variable speeds (FPM)	73-312	73-312
Blade	121 3/4" x 1" x .035"	121 3/4" x 1" x .035"
Table height from floor	30"	30"
Motor	15 Amp.	2.6 Amp.
Voltage	220V, 1 phase, 60 Hz	600V, 3 phase, 60 Hz
Assembled dim. (LxWxH)/weight	81" x 28" x 48" / 845 lbs	81" x 28" x 48" / 845 lbs
Package dim. (LxWxH)/weight	73" x 32" x 51" / 980 lbs	73" x 32" x 51" / 980 lbs

WARNING!

ALL ELECTRICAL CONNECTIONS MUST BE DONE BY A QUALIFIED ELECTRICIAN. ALL ADJUSTMENTS OR REPAIRS MUST BE DONE WITH THE MACHINE DISCONNECTED FROM THE POWER SOURCE. FAILURE TO COMPLY MAY RESULT IN SERIOUS INJURY!

600V OPERATION

If you purchased model KC-228S-V-6, 600V model, consult a qualified electrician for all electrical requirements and connections.

220V POWER SUPPLY & OPERATION

If you purchased the KC-228S-V-2, 220V model, follow the instructions and warnings below.

WARNING: YOUR BANDSAW MUST BE CONNECTED TO A 220V, 20 AMP. BRANCH CIRCUIT.

Your bandsaw is wired to operate on a 220V, 20amp. circuit. This bandsaw is intended for use on a circuit that has an outlet and a plug configuration which looks like the one illustrated in Fig.1.

GROUNDING

This bandsaw must be grounded. If it should malfunction or breakdown, grounding provides a path of least resistance for electric current, to reduce the risk of electric shock. This bandsaw is equipped with a cord having an equipment-grounding conductor (no plug installed). The plug must be properly installed and then plugged into an appropriate outlet that is properly installed and grounded in accordance with all local codes and ordinances.

WARNING: DO NOT USE A TWO-PRONG ADAPTOR FOR THEY ARE NOT IN ACCORDANCE WITH LOCAL CODES AND ORDINANCES. NEVER USE IN CANADA.

A 220V plug is not supplied with the bandsaw and must be purchased at your local hardware store. The 220V plug must be a CSA listed plug suitable for 220V operation. This plug is illustrated in Fig.1. Contact your authorized service centre or qualified electrician to install the plug.

EXTENSION CORDS

WARNING! IT IS NOT RECOMMENDED TO USE AN EXTENSION CORD, BUT IF IT IS NECESSARY, READ THE FOLLOWING.

The use of any extension cord will cause some loss of power. Use the chart Fig.2 to determine the minimum wire size (A.W.G-American Wire Gauge) extension cord required. Use only 3-wire extension cords which have 3-prong grounding type plugs and 3-hole receptacles which accept the tool's plug. For circuits that are further away from the electrical circuit box, the wire size must be increased proportionately in order to deliver ample voltage to the motor. The wire gauge number decreases the longer the extension cord needs to be.

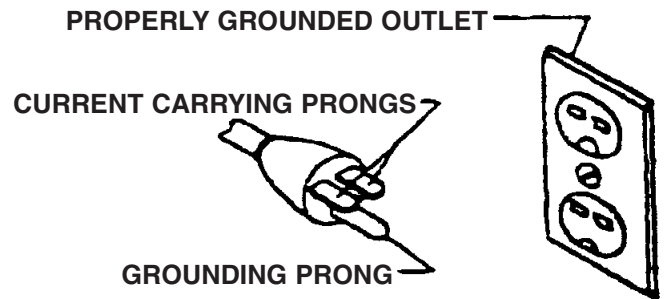

FIGURE 1

Tool's Amperage Rating	Cord Size in A.W.G.			
	Cord Length in Feet			
	25	50	100	150
3-6	18	16	16	14
6-8	18	16	14	12
8-10	18	16	14	12
10-12	18	16	14	12
12-16	14	12	-	-

FIGURE 2

ADJUSTING DOWNWARD TRAVEL OF SAW ARM

When the saw arm is in the extreme downward position, the teeth of the blade should be 1/16" below the table surface. If an adjustment is necessary, loosen the hex. nut (A) Fig.3, and turn the rubber stop (B) in or out until the correct adjustment is made. Then retighten hex. nut (A).

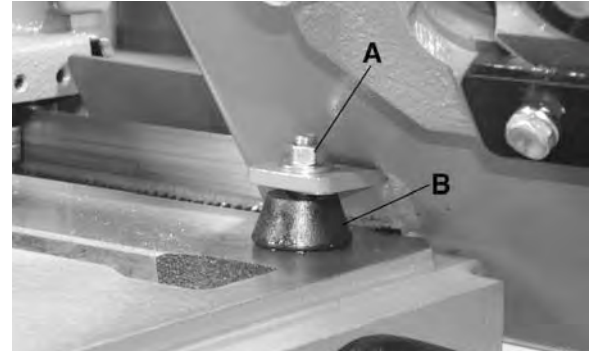

FIGURE 3

CHANGING SPEEDS AND ADJUSTING V-BELT TENSION

The cutting speed is controlled by the variable speed dial (A) Fig.4. Turn the dial clockwise to decrease the cutting speed or counterclockwise to increase the cutting speed. Refer to the speed meter (B) for speed setting. Always change cutting speed while the machine is on and make sure the belt/pulley cover (C) is always installed.

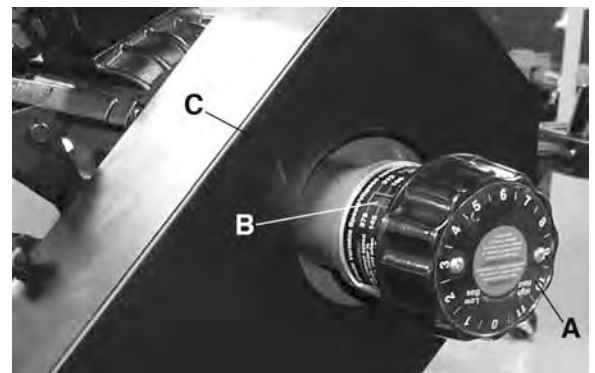

FIGURE 4

If the V-belt gets loose, adjust the V-belt tension by lifting the motor until there is approximately 1/2" deflection of the belt at the center span of the pulleys using light finger pressure. Then tighten tension lock ring (A) Fig.5 and reinstall belt/pulley cover.



FIGURE 5

ADJUSTING BLADE TENSION

To tension the blade, turn the blade tension handles (A) Fig. 6, clockwise. A blade tension scale (B) located behind the tension handles is graduated to indicate blade tension from 0-25,000 PSI. Carbon blades (similar to the one supplied with this bandsaw) should be tensioned at 20,000 PSI. For bi-metal blades, the blade should be tensioned at 25,000 PSI. Do not exceed 21,000 PSI if using a 3/4" blade and 25,000 PSI using a 1" blade. Always release blade tension at the end of each work day to prolong blade life.

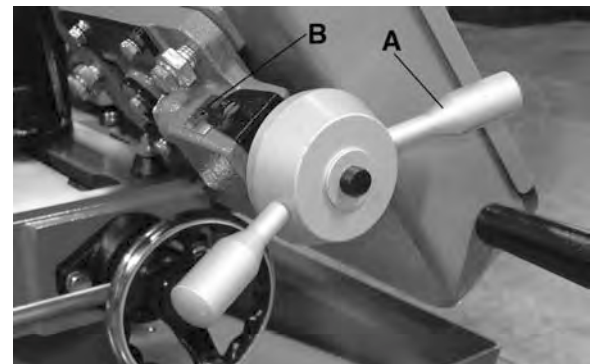

FIGURE 6

ADJUSTMENTS



ADJUSTING BLADE TRACKING

Make sure the blade is tensioned correctly before checking or adjusting blade tracking.

The blade is tracking properly when the back of the blade is just lightly touching the wheel flanges of both wheels while the machine is running. If the blade is not touching the wheel flanges, loosen hex. bolt (A) Fig.7, then tighten or loosen the special hollow hex. bolt (B) until the blade tracks properly.

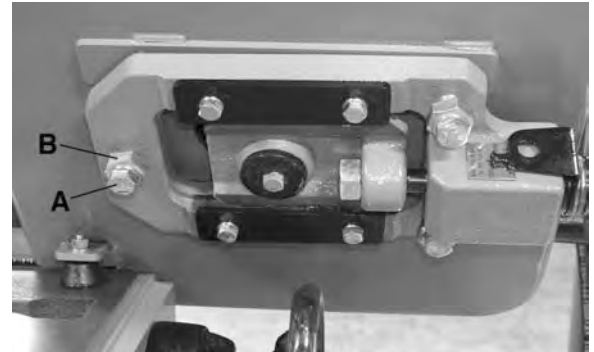

FIGURE 7

ADJUSTING BLADE GUIDE SUPPORT ARM

The blade guide support arm (A) Fig. 8, should be set as close to the workpiece as possible. To move the support arm, first loosen clamp knob (B). Move the support arm (A) into relationship with the workpiece. When you are sure the support arm will not interfere with the workpiece, tighten clamp knob (B). Although the second blade guide support arm (C) works in the same manner, its complete right position should not be changed.

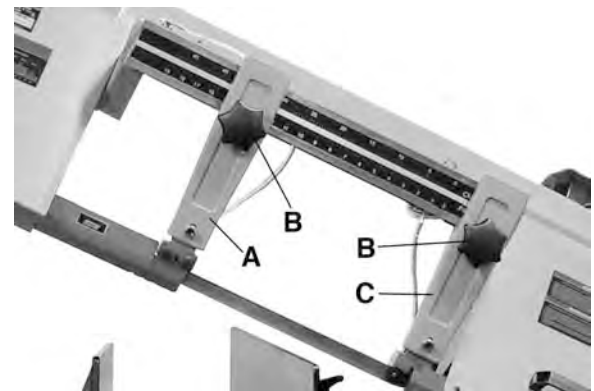

FIGURE 8

ADJUSTING CUTTING PRESSURE OF SAW ARM

The cutting pressure of the saw arm has been set at the factory and should not need further adjustment.

If adjustment should ever become necessary, lower the saw arm to the horizontal (down) position. Loosen hex. nut (A) Fig. 9 to increase the cutting pressure or tighten the hex. nut to decrease the cutting pressure.



FIGURE 9

OPERATING AND ADJUSTING TRU-LOCK VISE SYSTEM

The workpiece gets placed between the vise jaws with the amount to be cut-off extending out past the blade. Your bandsaw is equipped with a "TRU-LOCK™" cam locking lever and a "quick action" vise jaw which allows you to quick position and lock the vise jaw against your workpiece. To operate these mechanisms, proceed as follows:

- 1) Put your workpiece on the table and raise the cutting arm 2" above the workpiece. Turn the hydraulic cylinder shut-off dial to the "Off" position to maintain the cutting arm 2" above the workpiece.
- 2) Position the cam lock lever (A) Fig.10 in the upwards position, turn the handwheel (B) a 1/4 turn at a time counterclockwise until you are able to move the vise jaw (D). Once the vise jaw is in position close to the workpiece, turn the handwheel clockwise and lower the cam lock lever (A) to its down position as shown in Fig.10 to firmly hold your workpiece.
- 3) To loosen the workpiece from the vise, hold the workpiece and lift the cam lock lever (A) to its upwards position (completely opened) and remove workpiece.

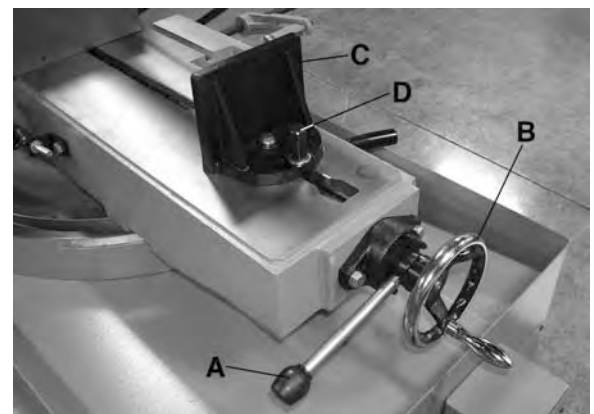

FIGURE 10

When you need to cut workpieces of the same dimension many times, just raise the cam lock lever (A) to loosen and adjust workpiece position. Then push it downwards again to retighten.

OPERATING AND ADJUSTING TRU-LOCK VISE SYSTEM cont.....

The right side vise (C) Fig.11 comes bolted to a support (B) for transportation purposes and must be unbolted before it can be used. Loosen and remove cap screw (A). The vise and pivot table can now be used.

The vise can be adjusted to cut any angle from a straight 90 degree cut-off to 45 degree angle. To adjust the angle of both vise jaws, first loosen the spring loaded clamp handle (A) Fig.12 on the right side vise jaw (B) and position it to the desired angle and retighten the spring loaded handle.

Then loosen the hex. shaft (D) Fig.10 on the left side vise jaw (C) with a 19mm open ended wrench. Place your workpiece on the table and tighten the vise jaw against it and tighten the hex. shaft to secure angle.

The right side vise jaw comes with positive stops to instantly position the vise jaw at 90 or 45 degrees. To check and adjust the positive stops, proceed as follows:

1. To check the 45 degree positive stop, pivot the right side vise jaw all the way to the left, and lock the spring loaded clamp handle.
2. Place one end of a 45 degree square against the vise jaw and the other end against the blade and check to see if the vise jaw is 45 degrees to the blade. See Fig.13.
3. If an adjustment is necessary, loosen clamp handle and then loosen locking set screw (C) Fig.12 and turn adjusting set screw (D) until the vise jaw is at 45 degrees to the blade. Note: The end of set screw (D) should contact the stud of clamp handle when vise jaw is 45 degrees to the blade. Then tighten set screw (C).
4. To check the 90 degree positive stop, pivot the right side vise jaw all the way to right and lock spring loaded clamp handle.
5. Place one end of a 90 degree square against the vise jaw and the other end against the blade and check to see if the vise jaw is 90 degrees to the blade.
6. If an adjustment is necessary, loosen clamp handle and then loosen locking set screw (E) Fig.12 and turn adjusting set screw (F) until the vise jaw is 90 degrees to the blade. Note: Turn set screw (F) from the opposite end, through the face of the vise jaw. The end of set screw (F) should contact stud of clamp handle when vise jaw is 90 degrees to the blade. Then tighten set screw (E).

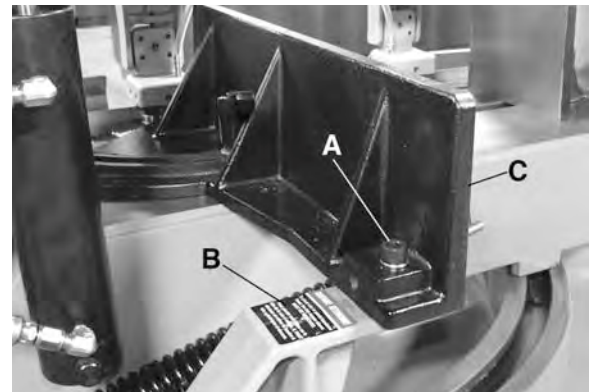

FIGURE 11

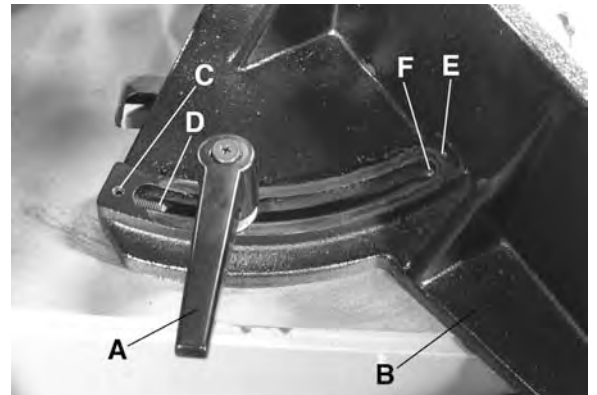

FIGURE 12

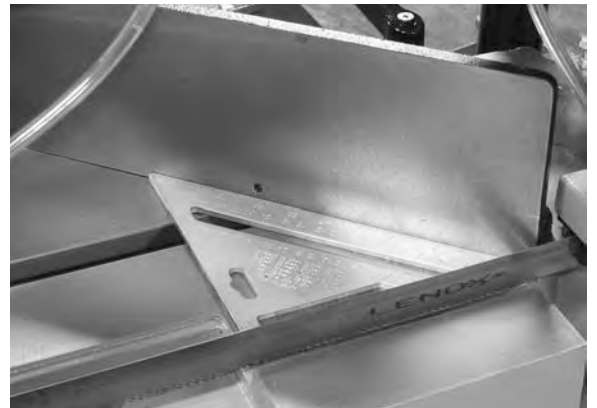

FIGURE 13

ADJUSTING STOCK ADVANCE STOP

The stock advance stop Fig.14 is used mainly when more than one piece of work is to be cut to the same length. Simply position the stop bolt (A) Fig.14 to the desired distance away from the blade.

The stop bracket (B) may be repositioned up or down by loosening lock knob (C), the stop arm (D) can also be adjusted in or out on the stop rod (E) by loosening the stop arm set screw (not shown- it is under the stop arm D).

Fine adjustment to the stop can be made by loosening hex. nut (F) and turning stop bolt (A).

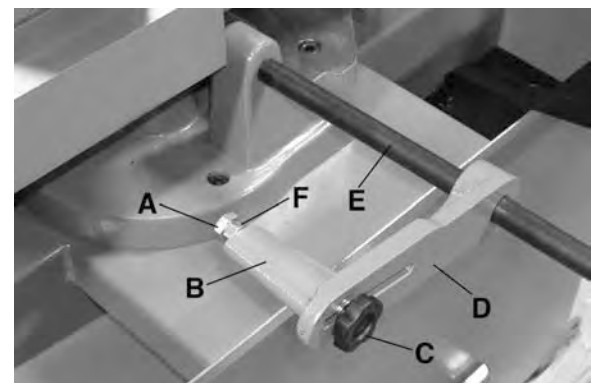

FIGURE 14

ADJUSTMENTS



SWIVEL TABLE ADJUSTMENT FOR ANGLED CUTS

The swivel table (A) Fig.15 can be swiveled 0-45° for angled cuts.

1. Move the swivel table lock lever (B) Fig.15 towards the left to unlock swivel table (A).
2. Rotate the swivel table to the desired angle using the angle scale (C). Move the swivel table lock lever (B) towards the right to lock swivel table (A).
3. Loosen vise jaws so they can swivel into the same angle as the swivel table. Secure vise jaw angles and then secure workpiece.

ADJUSTING BLADE BACK-UP BEARINGS, BLADE GUIDE ROLL BEARINGS AND CARBIDE BLADE GUIDES

Before making the following adjustments make sure the blade is tensioned and tracking properly:

1. The back of the blade should ride against the back-up bearing (A) Fig.16. To adjust, loosen cap screw (A) Fig.17 and tighten the set screw (B) Fig.16 to move the entire blade guide assembly down until the back-up bearing lightly touches the back of the blade.
2. The saw blade should also ride between and lightly touch the two blade guide roller bearings (C & D) Fig.16. Both bearings are mounted on eccentric shafts. Normally it is longer bearing shaft assembly (C) which is adjusted to suit blade thickness, this is done by loosening set screw (E) and turning shaft (F).
3. The carbide blade guides (G) Fig.16, should also be adjusted so they lightly touch the blade, this is done by loosening cap screws (H).
4. The blade guide roller bearings, carbide blade guides and back-up bearing on holder (B) Fig.17 should be adjusted in the same manner.

SQUARING THE BLADE TO THE TABLE

Before making the following adjustments make sure the blade is tensioned and tracking properly:

If you find that the bandsaw is not cutting square, you may need to adjust the blade square with the table.

1. Examine the workpiece and try to determine which way the blade is twisting or place a 90 degree square on the table and against the blade as shown in Fig.17.
2. Check for gaps along the blade, in order to bring the blade into proper squareness with the table, it will be necessary to adjust the blade guide block assemblies.
3. To make this adjustment, first loosen the set screws (A) Fig.18 (on both blade guide block assemblies).
4. Then adjust set screws (B & C) to pivot the blade guide block assembly. To pivot the blade guide block assembly inwards (towards the bandsaw), tighten the 2 lower set screws (C). For outwards travel, tighten the 2 upper set screws (B).
5. Adjust these set screws in pairs and adjust them until the blade is perfectly square with the table. Don't forget to retighten the 2 set screws (A) Fig.18 loosened previously.

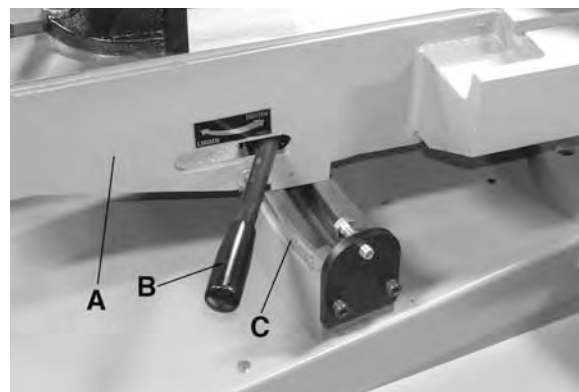

FIGURE 15

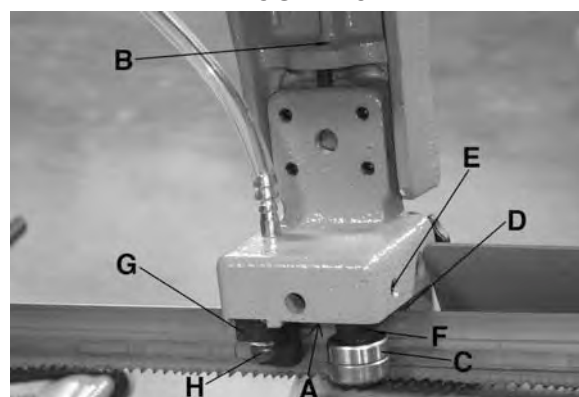

FIGURE 16

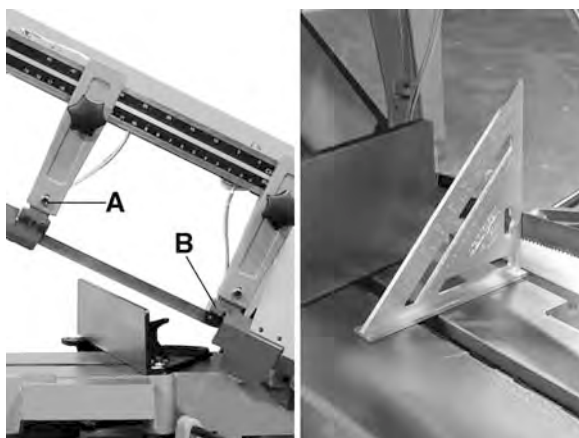

FIGURE 17

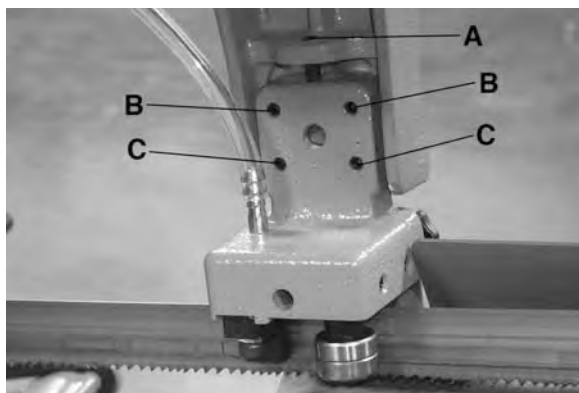

FIGURE 18

OPERATING CONTROLS

CONTROL PANEL

1. Raise the saw frame to the up position.
2. The machine is started by pushing the start button (A) Fig.19. The “Power On” light (C) will turn on. The bandsaw will continue to run until the saw arm is in the down position at the end of the cut, or when the stop button (B) is pushed.
3. The down feed speed can be adjusted by setting the feed rate knob (D). If you need to quickly stop the down feed of the saw arm, turn the hydraulic shut-off valve knob (F) to the right (red symbol) to stop. To restart the down feed at the identical feed rate set before, turn the hydraulic shut-off valve knob (F) to the left (green symbol).
4. To begin the coolant flow of the coolant pump during cutting operations, turn the coolant knob (E) to the left, to stop the coolant flow turn the coolant knob to the right.



FIGURE 19

AUTOMATIC SHUT-OFF LIMIT SWITCH

1. An automatic shut-off limit switch is provided to stop the motor when the cut is completed. The limit switch (A) Fig.20 comes into contact the top of the stop bolt (B) shutting off the motor and coolant pump.
2. If the motor stops before the cut is completed, or continues to run after the cut is completed, the height of the stop bolt (B) can be adjusted to make it contact earlier or later. Loosen the hex. nut (C), adjust the height of the stop bolt up or down, and make a test. Once this adjustment is done, retighten the stop bolt hex. nut.

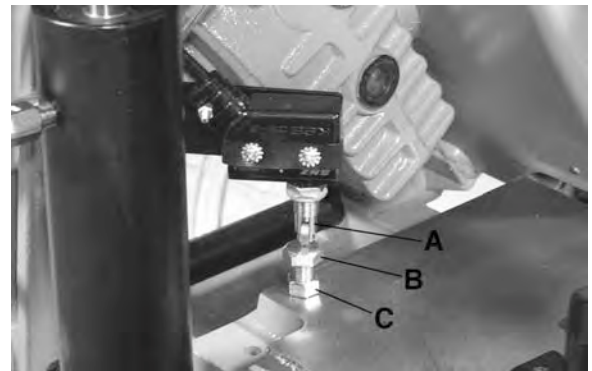

FIGURE 20

COOLANT SYSTEM

The bandsaw comes with a built-in coolant pump (A) Fig.21 and coolant fluid recirculating system. Using coolant during operations will extend the life of your blades by lowering the temperature of the blade and workpiece during cuts.

Setting up the coolant system:

An enclosed section of the machine base is used as the coolant fluid reservoir, it comes with a chip tray (B) Fig.21 to prevent metal chips from entering the coolant fluid reservoir. Fill the reservoir with approximately 30 litres of your chosen cutting fluid solution (see your nearest car parts or industrial machinery dealer for more information) through the chip tray (B).

The rate of coolant flow is controlled by 2 independently operated stop valve levers (A -one of two) Fig.22, which direct the coolant onto the blade at 2 different areas under each control arm. When doing small cutting operations, only use one to direct coolant flow to the workpiece. If additional coolant flow is required to cover a larger cutting area, turn on the second stop valve lever and position the control arms as close to the workpiece as possible.

WARNING! Clean the screen of the chip tray (B) Fig.21 so coolant can drain back to the coolant reservoir. .

BIOLOGICAL AND POISON HAZARD! During storage some fluids grow dangerous microbes, or due to the collection of toxic metal chips in the fluid, the fluid can become a potent and extremely poisonous solution to humans and animals. Use proper personal protection equipment when handling cutting fluid and follow provincial laws and fluid manufacturer requirements to properly dispose of coolant fluid.

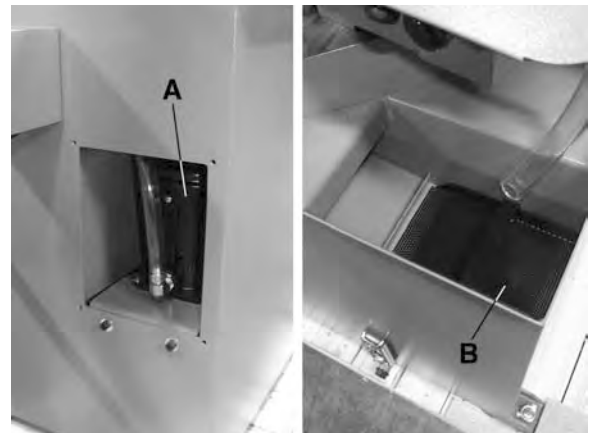

FIGURE 21

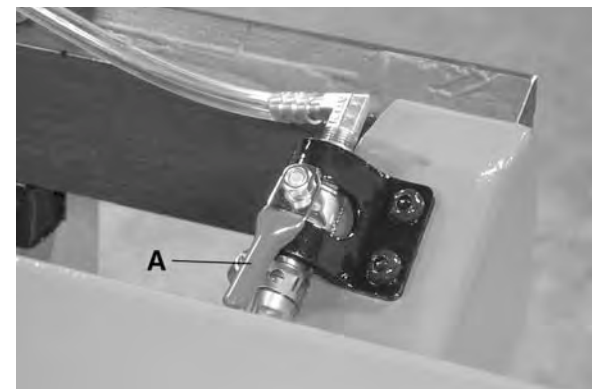

FIGURE 22

OPERATION



REMOVING AND INSTALLING A BLADE

Blades should be changed when they become dull, damaged or when you want to cut materials which require a blade of a certain type or tooth count. It is recommended to wear gloves during the removal and installation of a blade.

1. Disconnect the machine from power source.
2. Raise the saw frame to clear the table and turn the hydraulic shut-off valve knob (F) Fig.19 to the right (red symbol) to keep the saw frame in this position.
3. Open both wheel covers (A) Fig.23 and clean the debris out of the machine.
4. Release blade tension by turning the blade tension levers (B) counterclockwise.
5. Loosen two lock knobs (C) and remove blade guard (D).
6. Remove two lock knobs (E) and remove top blade guard (F).
7. Remove the blade (G) from both wheels and out of each blade guide.
8. Before installing a new blade, make sure the teeth are pointing in the right direction (towards the workpiece). If necessary, turn the blade inside out.
9. Place the new blade on the wheels and follow the blade guide, tensioning and tracking adjustments in this manual and reposition all blade guards removed previously.

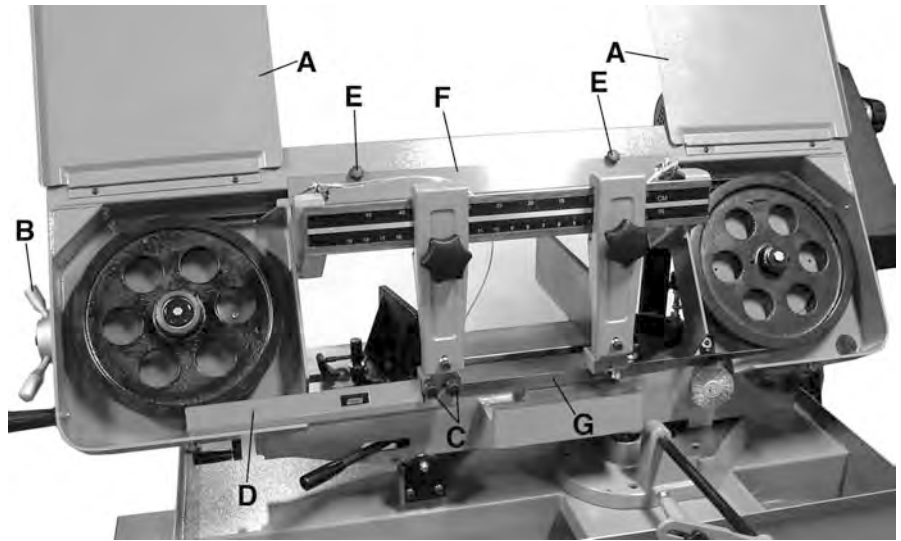

FIGURE 23

PROPER BLADE TOOTH SELECTION

You need to consider:

1. **THE WIDTH OF CUT.** That is, the distance in the cut that each tooth must travel from the point it enters the workpiece until it leaves the workpiece.
2. **THE SHAPE OF THE WORKPIECE**
 - **Squares, rectangles, flats.** (Solid square symbol) EX.: 6" (150mm) Square, use a 2/3 Vari-Tooth.
 - **Round solids** (Solid circle symbol). EX.: 4" (100mm) round, use a 3/4 Vari-Tooth.
 - **Tubing, pipe, structurals** (OHΛ symbols). Determine the average width of cut by dividing the area of the workpiece by the distance the saw blade must travel to finish the cut. EX.: 15" (380mm), use a 2/3 Vari-Tooth.

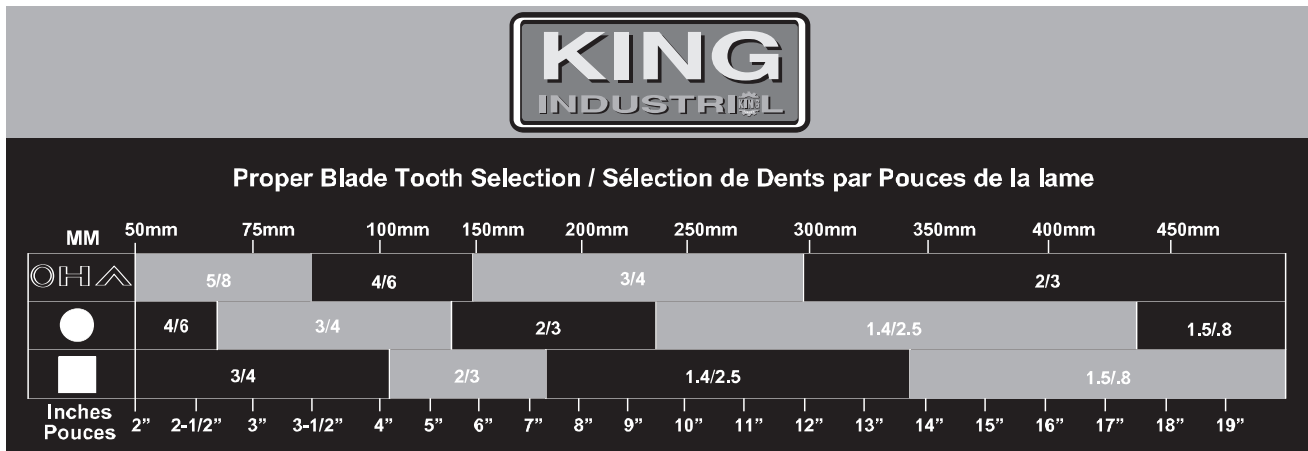

FIGURE 24

BLADE SPEEDS VERSUS TYPE OF MATERIAL

Speed FPM	Material to be cut
73-100	Tool Steel, Stainless Steel, Alloy Steel, Phosphor & Hard Bronze, Hard Cast-Iron and Malleable Iron
100-166	Mild Steel, Soft Cast-Iron, Medium-Hard Brass and Medium-Hard Bronze
166-245	Soft Brass, Soft Bronze, Hard Aluminum and Plastics
245-312	Plastics, Soft/Medium Soft Aluminum, Wood and other light materials

FIGURE 25

SETTING UP THE MACHINE FOR OPERATION

1. Depending on the material to cut, select and install the proper blade and set the proper blade speed.
2. Make sure the blade tension is adjusted and that the blade is tracking properly.
3. Raise the saw frame and close the feed on/off knob (A) Fig.26.
4. Place workpiece between the vise jaws. Adjust the stock for the desired length of cut, tighten the vise handwheel (B) and lower the cam lock lever (C) to firmly secure workpiece.
5. Make sure the blade guide control arm (D) is adjusted as close as possible to the workpiece.
6. Turn the coolant selector (E) to the "On" position, then turn machine on by pressing the "On" button (F). Note: If the "Emergency stop/off" button (G) is pressed, it needs to be twisted until it pops out or the bandsaw will not start. Just in case, keep your finger near the "Emergency stop/off" button at all times during the operation. The bandsaw should run smoothly with little or no vibration.
7. Adjust the coolant flow using one or both coolant valves (H & I) above the control arms.
8. Turn the feed rate control knob (J) counterclockwise until the saw blade begins to lower, see the feed rate guideline section below as reference.
9. Proceed to cut through the workpiece. The motor and coolant pump will shut off upon completion of the cut.

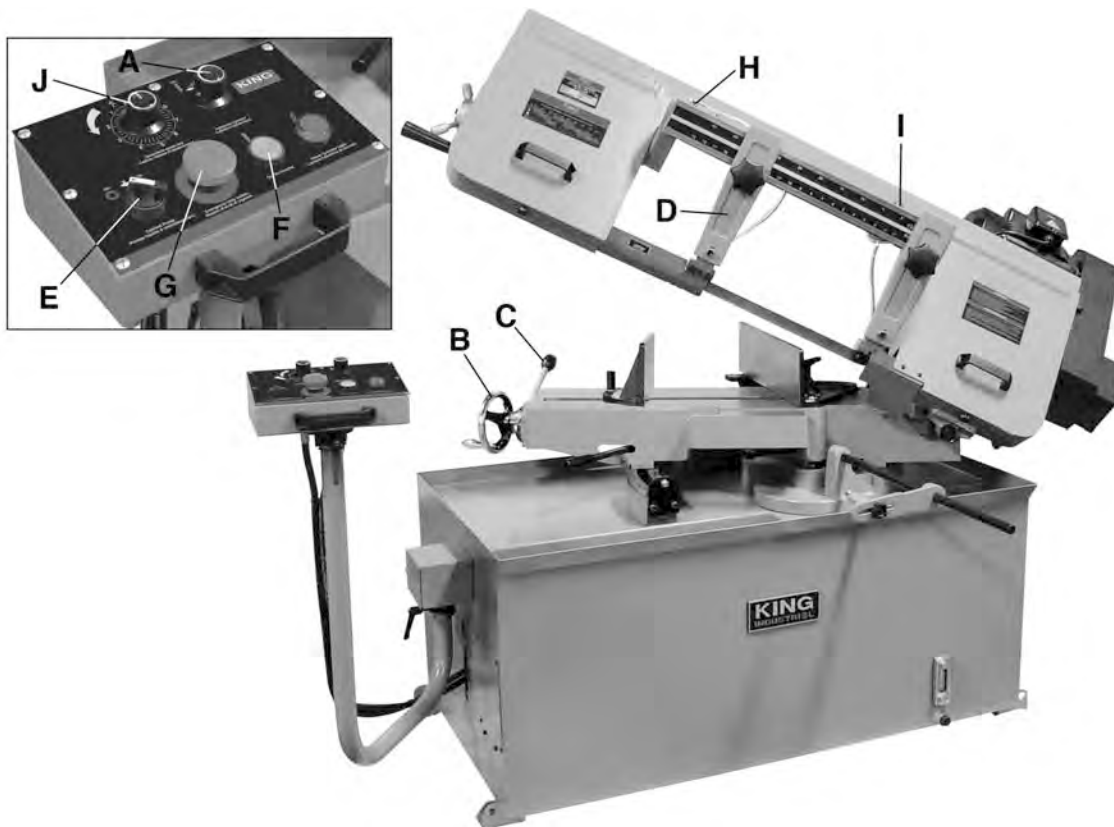

FIGURE 26

FEED RATE GUIDELINES

When the feed rate control knob (J) Fig.26 is turned clockwise as far as it will go, the saw frame will not move down, but can be raised to the up position. Turning the feed rate control knob counterclockwise, the flow of oil from the cylinder is regulated and determines the speed at which the saw frame will lower and the blade will feed through the work. Too many factors are involved to make tabulated data practical on feed rates. As a general rule, an even downward pressure without forcing the blade gives best results. Burned chips indicate excessive feed, which causes the teeth to break off as the blade overheats. The ideal feed rate is indicated by chips that have a free curl and this will give the fastest cutting time and longest blade life.

OPERATIONAL TIPS

1. Let the blade reach full speed before engaging the workpiece.
2. Never start a cut with the blade in contact with the workpiece, and do not start a cut on a sharp edge.
3. Chips should be curled and silvery. If the chips are thin and powder like, increase your feed rate.
4. Burned chips indicate a need to reduce your blade speed.
5. Wait until the blade has completely stopped before removing the workpiece from the vise, and avoid touching the cut end—it could be very hot!
6. Use coolant when possible to increase blade life.

REGULAR MAINTENANCE

Blade and blade guides: Place a few drops of light machine oil on the blade and the blade guides daily, especially when cutting cast iron, coolant fluid is not recommended on cast iron.

Table and machined surfaces: Table and machined surfaces should be kept rust-free with regular applications of paste wax.

Vise leadscrew: Place a few drops of light machine oil on the vise leadscrew weekly.

REPLACING GEAR BOX OIL

DO NOT operate saw without checking gear box oil level! Operating without sufficient oil will damage the machine!

The gear box should be drained and refilled after the first 50 hours of use and thereafter every 6 months, with 80W-90 Gear Oil.

To change gear box oil, proceed as follows:

1. Run the machine for 10 minutes to warm up the gear box.
2. Disconnect the machine from the power source.
3. Raise the saw arm to its maximum position and close the feed rate control knob.
4. Drain the gear box by removing drain bolt (A) Fig.27.
5. Replace drain bolt (A) and lower the saw arm to its lowest position.
6. Remove oil cap (B) and fill the gear box with oil through the oil cap opening until the oil level reaches the halfway mark (red dot) in the oil sight glass (C) (approximately 500 ml). Reinstall the oil cap (B).

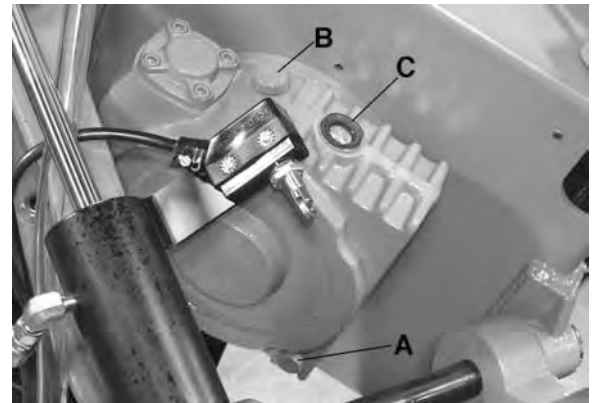

FIGURE 27