

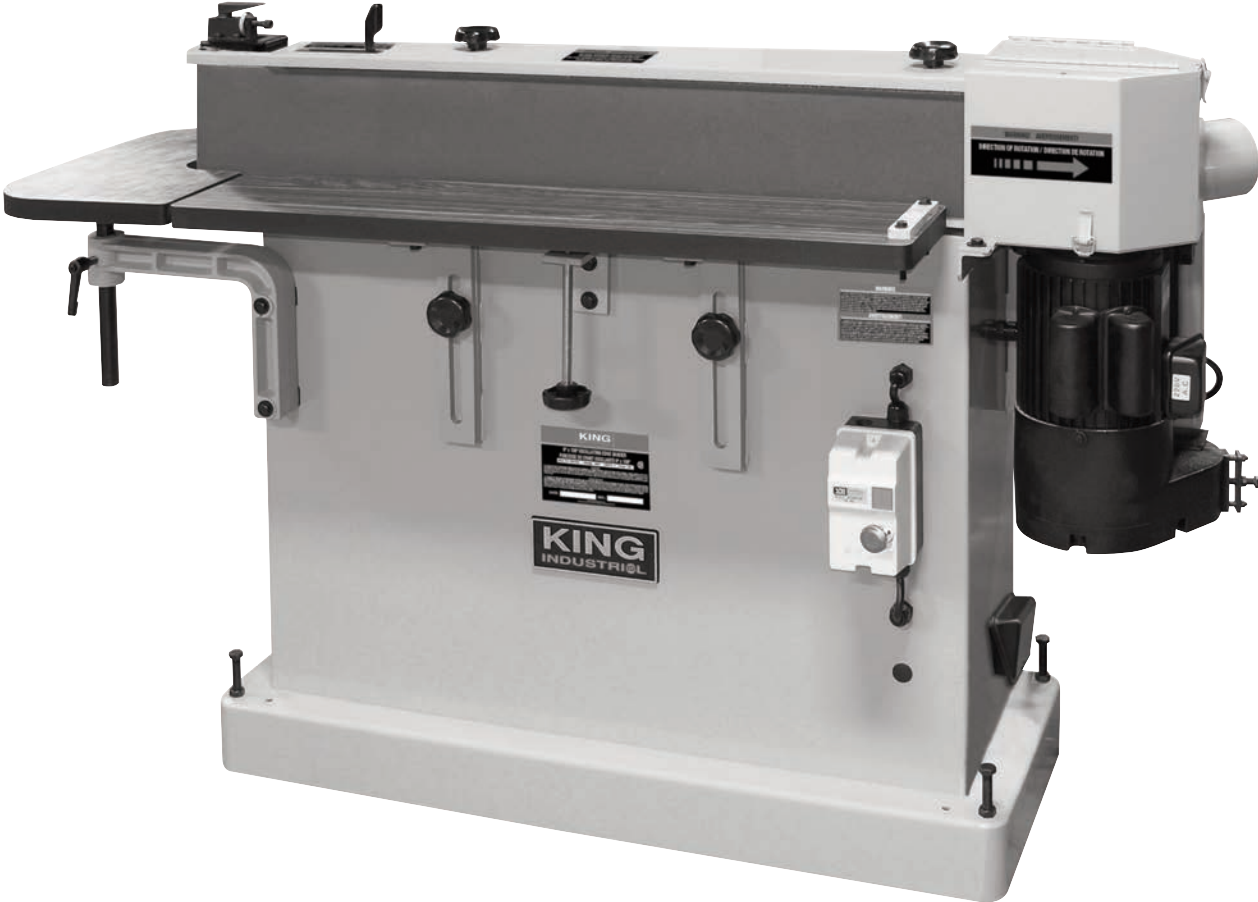

# 6" x 108" OSCILLATING EDGE SANDER

04/2017



MODEL: KC-108-OSC

# INSTRUCTION MANUAL

COPYRIGHT © 2016 ALL RIGHTS RESERVED BY KING CANADA TOOLS INC.



## WARRANTY INFORMATION

**2-YEAR  
LIMITED WARRANTY  
FOR THIS OSCILLATING EDGE SANDER**

**KING CANADA TOOLS  
OFFERS A 2-YEAR LIMITED WARRANTY  
FOR COMMERCIAL USE.**

### **PROOF OF PURCHASE**

Please keep your dated proof of purchase for warranty and servicing purposes.

### **REPLACEMENT PARTS**

Replacement parts for this product are available at our authorized King Canada service centres across Canada.

### **LIMITED TOOL WARRANTY**

King Canada makes every effort to ensure that this product meets high quality and durability standards. King Canada warrants to the original retail consumer a 2-year limited warranty as of the date the product was purchased at retail and that each product is free from defects in materials. Warranty does not apply to defects due directly or indirectly to misuse, abuse, normal wear and tear, negligence or accidents, repairs done by an unauthorized service centre, alterations and lack of maintenance. King Canada shall in no event be liable for death, injuries to persons or property or for incidental, special or consequential damages arising from the use of our products.

To take advantage of this limited warranty, return the product at your expense together with your dated proof of purchase to an authorized King Canada service centre. Contact your retailer or visit our web site at [www.kingcanada.com](http://www.kingcanada.com) for an updated listing of our authorized service centres. In cooperation with our authorized serviced centre, King Canada will either repair or replace the product if any part or parts covered under this warranty which examination proves to be defective in workmanship or material during the warranty period.

### **NOTE TO USER**

This instruction manual is meant to serve as a guide only. Specifications and references are subject to change without prior notice.

### **PARTS DIAGRAM & PARTS LISTS**

Refer to the Parts section of the King Canada web site for the most updated parts diagram and parts list.

**KING CANADA INC. DORVAL, QUÉBEC, CANADA H9P 2Y4**

**[www.kingcanada.com](http://www.kingcanada.com)**

# GENERAL SAFETY INSTRUCTIONS



**VOLTAGE WARNING:** Before connecting the machine to a power source (receptacle, outlet, etc.) be sure the voltage supplied is the same as that specified on the nameplate. A power source with voltage greater than specified can result in **SERIOUS INJURY** to the user - as well as damage the machine. If in doubt **DO NOT PLUG IN THE TOOL**. Using a power source with voltage less than the nameplate is harmful to the motor.

## 1. KNOW YOUR MACHINE

Read and understand the owners manual and labels affixed to the machine. Learn its application and limitations as well as its specific potential hazards.

## 2. GROUND THE MACHINE.

This machine is equipped with an approved 3-conductor cord and a 3-prong grounding type plug to fit the proper grounding type receptacle. The green conductor in the cord is the grounding wire. **NEVER** connect the green wire to a live terminal.

## 3. KEEP GUARDS IN PLACE.

Keep in good working order, properly adjusted and aligned.

## 4. REMOVE ADJUSTING KEYS AND WRENCHES.

Form habit of checking to see that keys and adjusting wrenches are removed from the machine before turning it on.

## 5. KEEP WORK AREA CLEAN.

Cluttered areas and benches invite accidents. Make sure the floor is clean and not slippery due to wax and dust build-up.

## 6. AVOID DANGEROUS ENVIRONMENT.

Don't use machinery in damp or wet locations or expose them to rain. Keep work area well lit and provide adequate surrounding work space.

## 7. KEEP CHILDREN AWAY.

All visitors should be kept a safe distance from work area.

## 8. MAKE WORKSHOP CHILD-PROOF.

Use padlocks, master switches or remove starter keys.

## 9. USE PROPER SPEED.

A machine will do a better and safer job when operated at the proper speed.

## 10. USE RIGHT TOOL.

Don't force the machine or the attachment to do a job for which it was not designed.

## 11. WEAR PROPER APPAREL.

Do not wear loose clothing, gloves, neckties or jewelry (rings, watch) because they could get caught in moving parts. Non-slip

footwear is recommended. Wear protective hair covering to contain long hair. Roll up long sleeves above the elbows.

## 12. ALWAYS WEAR SAFETY GLASSES.

Always wear safety glasses (ANSI Z87.1). Everyday eyeglasses only have impact resistant lenses, they are **NOT** safety glasses. Also use a face or dust mask if cutting operation is dusty.

## 13. DON'T OVERREACH.

Keep proper footing and balance at all times.

## 14. MAINTAIN MACHINE WITH CARE.

Keep machine clean for best and safest performance. Follow instructions for lubricating and changing accessories.

## 15. DISCONNECT MACHINE.

Before servicing, when changing accessories or attachments.

## 16. AVOID ACCIDENTAL STARTING.

Make sure the switch is in the "OFF" position before plugging in.

## 17. USE RECOMMENDED ACCESSORIES.

Consult the manual for recommended accessories. Follow the instructions that accompany the accessories. The use of improper accessories may cause hazards.

## 18. NEVER STAND ON TOOL.

Serious injury could occur if the machine tips over. Do not store materials such that it is necessary to stand on the machine to reach them.

## 19. CHECK DAMAGED PARTS.

Before further use of the machine, a guard or other parts that are damaged should be carefully checked to ensure that they will operate properly and perform their intended function. Check for alignment of moving parts, breakage of parts, mounting, and any other conditions that may affect its operation. A guard or other parts that are damaged should be properly repaired or replaced.

## 20. NEVER LEAVE MACHINE RUNNING UNATTENDED.

Turn power "OFF". Don't leave any machine running until it comes to a complete stop.

## SPECIFIC SAFETY INSTRUCTIONS FOR OSCILLATING EDGE SANDERS

1. **DO NOT OPERATE THIS MACHINE UNTIL** it is assembled and installed according to the instructions.

2. **CHECK BELTS** for wear and tension. If the belt is damaged or can't be tensioned properly, replace it.

3. **CHECK FOR PROPER BELT INSTALLATION**, and make sure that the belt is tracking properly.

4. **KEEP ARMS, HANDS, AND FINGERS** away from abrasive surfaces.

5. **NEVER START THE SANDER** with the workpiece against the sanding belt or sanding sleeve.

6. **MAINTAIN MINIMUM CLEARANCE** between the table and the sanding surface.

7. **FEED THE WORKPIECE AGAINST THE ROTATION OF THE SANDING BELT OR SANDING SLEEVE.** Hold the workpiece securely on the table.

8. **DUST COLLECTION SYSTEM.** Never operate this sander without an adequate dust collection system connected and operating.

9. **DISCONNECT POWER.** Disconnect the sander power cord from the power source before changing the sanding belt or sanding sleeve.



# ELECTRICAL INFORMATION

## WARNING

ALL ELECTRICAL CONNECTIONS MUST BE DONE BY A QUALIFIED ELECTRICIAN. FAILURE TO COMPLY MAY RESULT IN SERIOUS INJURY! ALL ADJUSTMENTS OR REPAIRS MUST BE DONE WITH THE EDGE SANDER DISCONNECTED FROM THE POWER SOURCE. FAILURE TO COMPLY MAY RESULT IN SERIOUS INJURY!

## POWER SUPPLY

**WARNING:** YOUR EDGE SANDER MUST BE CONNECTED TO A 220V, 15-AMP. MINIMUM BRANCH CIRCUIT. FAILURE TO CONNECT IN THIS WAY CAN RESULT IN INJURY FROM SHOCK OR FIRE.

## GROUNDING

This Edge Sander must be grounded. If it should malfunction or breakdown, grounding provides a path of least resistance for electric current, to reduce the risk of electric shock. This Edge Sander is equipped with a cord having an equipment-grounding conductor. Once a plug is installed, the plug must be plugged into an appropriate outlet that is properly installed and grounded in accordance with all local codes and ordinances.

**WARNING:** TO MAINTAIN PROPER GROUNDING OF YOUR EDGE SANDER, DO NOT REMOVE OR ALTER THE PLUG GROUNDING PRONG IN ANY MANNER.

Not all outlets are properly grounded. If you are not sure if your outlet is properly grounded, have it checked by a qualified electrician.

**WARNING:** IF NOT PROPERLY GROUNDED, THIS EDGE SANDER CAN CAUSE ELECTRICAL SHOCK, PARTICULARLY WHEN USED IN DAMP LOCATIONS. TO AVOID SHOCK OR FIRE, IF THE POWER CORD IS WORN OR DAMAGED IN ANY WAY, HAVE IT REPLACED IMMEDIATELY.

## 220V OPERATION

A 220V plug is not supplied with this Edge Sander and must be purchased at your local hardware store. The 220V plug must be a CSA listed plug suitable for 220V operation. This plug is illustrated in Fig.1. Contact your authorized service centre or qualified electrician to install the plug.

## EXTENSION CORDS

**WARNING!** IT IS NOT RECOMMENDED TO USE AN EXTENSION CORD, BUT IF IT IS NECESSARY, READ THE FOLLOWING.

The use of any extension cord will cause some loss of power. Depending on the length of extension cord needed, use the table (Fig.2) to determine the minimum wire gauge (A.W.G-American Wire Gauge). Use only 3-wire extension cords which have 3-prong grounding type plugs and 3-hole receptacles which accept the tool's plug.

For circuits that are further away from the electrical circuit box, the wire thickness must be increased proportionately in order to deliver ample voltage to the Edge Sander motor. The smaller the gauge of the extension cord, the thicker it will be in diameter. Refer to Fig.2 for wire length and size.

## MAGNETIC SWITCH AND EMERGENCY STOP BUTTON

### Starting and Stopping the Edge Sander

The magnetic switch (A) Fig.3 is located on the front right side of the sander. To turn the sander "On" press the green button (B). To stop the sander, push the red emergency stop button (C). Once you push down on the emergency stop button (C), twist the button clockwise until it pops up, only then will you be able to restart the sander.

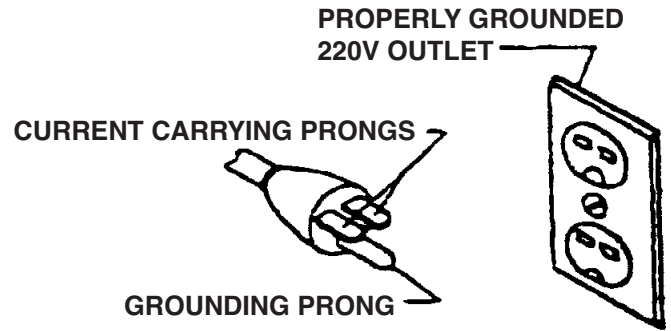

FIGURE 1

<u>LENGTH OF EXTENSION CORD</u>	<u>WIRE GAUGE REQUIRED (AMERICAN WIRE GAUGE)</u> <u>220V LINES</u>
0-25 FEET	NO.16
26-50 FEET	NO.14
51-100 FEET	NO.12

FIGURE 2

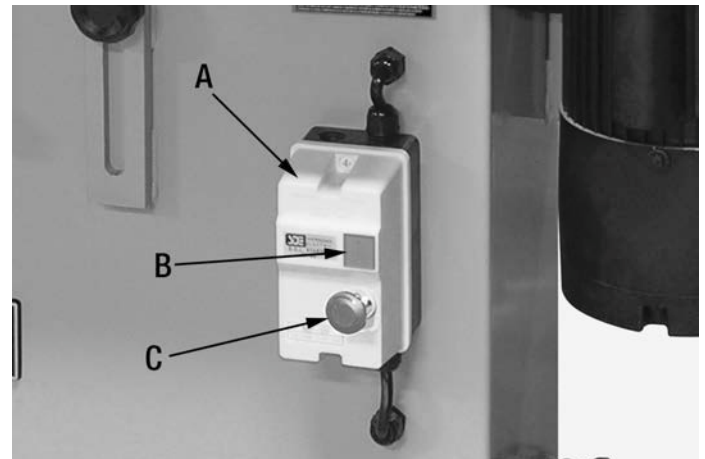
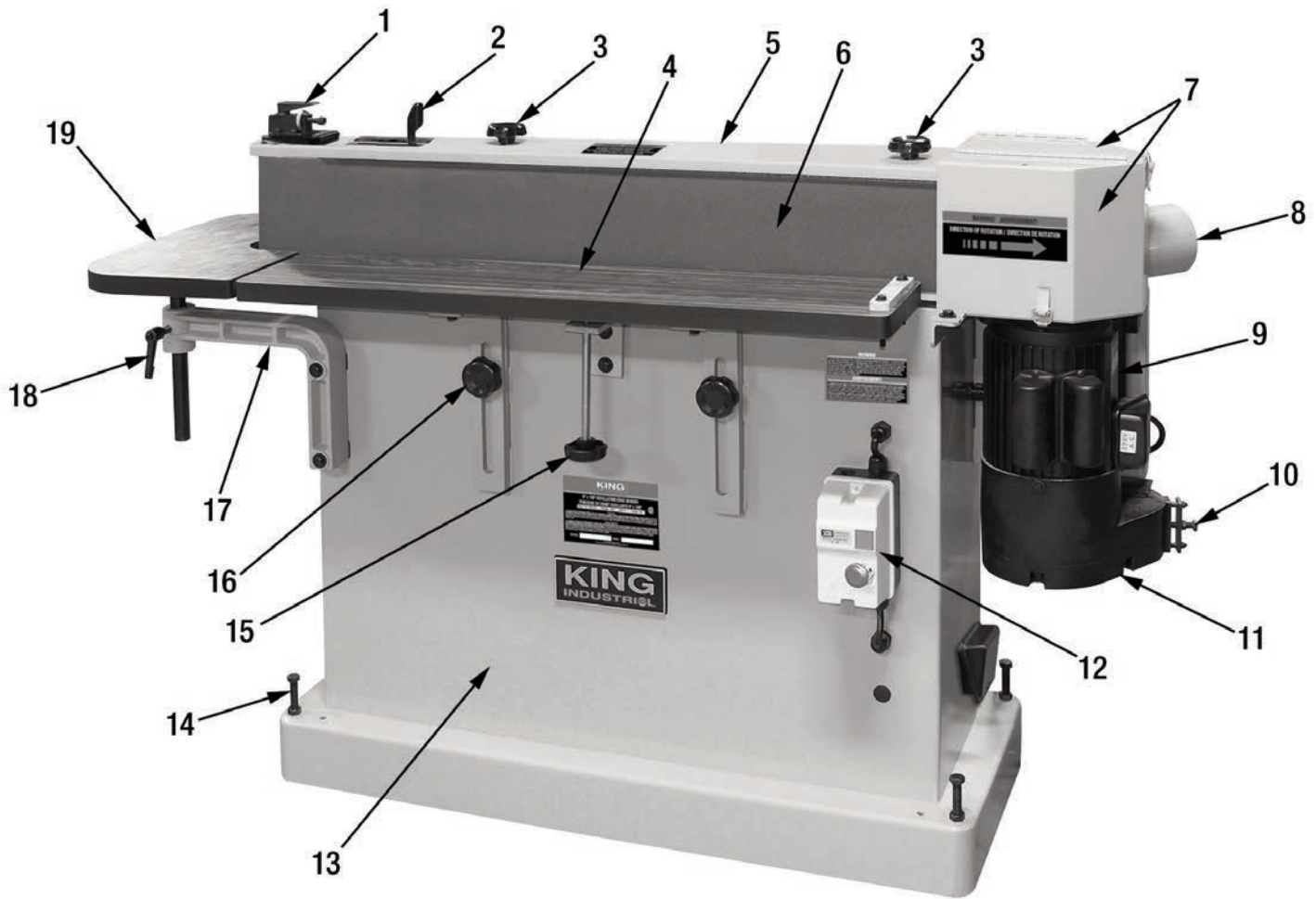

FIGURE 3

# GETTING TO KNOW YOUR OSCILLATING EDGE SANDER



- 1) Sanding belt tracking adjustment mechanism.
- 2) Belt tension lever.
- 3) Access panel lock knob (1 of 2).
- 4) Main work table.
- 5) Sanding belt access panel.
- 6) Sanding belt.
- 7) Sanding belt safety guards.
- 8) 4" dust chute.
- 9) Motor (220V).
- 10) Timing belt tension adjustment.

- 11) Gearbox and gearbox cover.
- 12) Magnetic safety switch.
- 13) Enclosed cabinet.
- 14) Leveling/Fixing bolt (1 of 4).
- 15) Main table height adjusting knob.
- 16) Main table lock knob (1 of 2).
- 17) End table support.
- 18) End table lock handle.
- 19) End table.

## SPECIFICATIONS

MODEL	KC-108-OSC
Belt	6" x 108"
Oscillating stroke	1/4"
Table size (front)	37" x 7 3/4"
Table size (side)	19" x 11-3/4"
Belt speed	3,150 SFPM
Motor	10 Amp. @ 220V
Voltage	220V, 1 phase, 60 Hz
Assembled dimensions (LxWxH)/weight	62" x 22-1/2" x 42" / 356 lbs
Package dimensions (LxWxH)/weight	60" x 25-1/4" x 46" / 450 lbs



# ASSEMBLY & SETUP

## UNPACKING AND SETTING UP YOUR SANDER

Warning! This sander weighs 356 lbs, use material handling equipment when moving shipping crate and removing sander from the crate. Carefully unpack the sander and all loose items inside the cabinet base.

This sander must be placed on a flat and even floor capable of supporting the machine weight.

## INSTALLING AND ADJUSTING THE HEIGHT OF THE FRONT MAIN TABLE

- 1) Locate the front main table (A) Fig.4 inside the enclosed cabinet.
- 2) Loosen and remove the two lock knobs (B) on the front of the cabinet.
- 3) Install the front main table to the cabinet using the removed lock knobs as shown in Fig.4.
- 4) Thread the table height adjusting knob (C) into the bracket under the table.
- 5) To adjust the height of the front main table (A) Fig.4, loosen the two lock knobs (B) and turn the height adjusting knob (C) to raise or lower the table.

**Note:** Adjusting the height of the table allows the user to use different sections of the sanding belt for even wear and prolonged belt life.

- 6) The front main table (A) Fig.5 can also be inclined left or right to allow sanding irregular workpieces. Loosen the two lock knobs (B) and raise or lower one end of the front main table. Retighten the two lock knobs (B) to secure the table position.

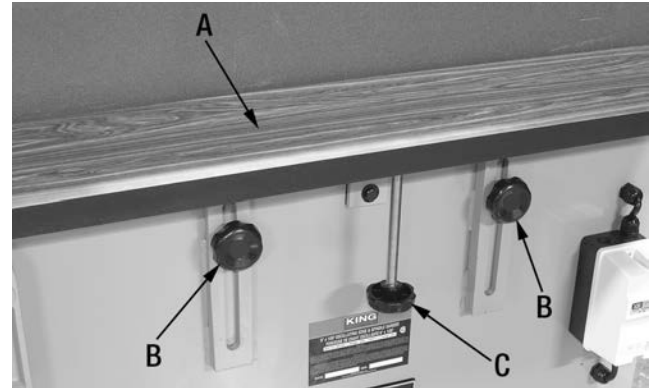

FIGURE 4

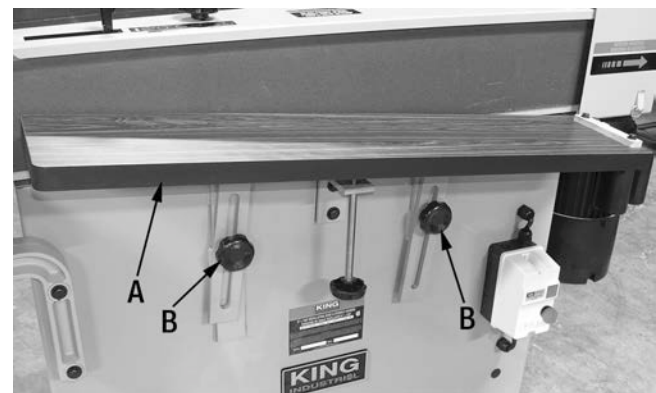

FIGURE 5

## INSTALLING AND ADJUSTING THE HEIGHT OF THE END TABLE

- 1) Locate the end table (A) Fig.6 inside the enclosed cabinet.
- 2) The end table support (B) needs to be unbolted and reinstalled to the cabinet as shown in Fig.6 using the same hardware.
- 3) Slide the end table shaft into the end table support, secure the end table using the lock handle (C).
- 4) To adjust the height of the end table, loosen lock handle (C) and position the end table to the desired height, retighten lock handle.

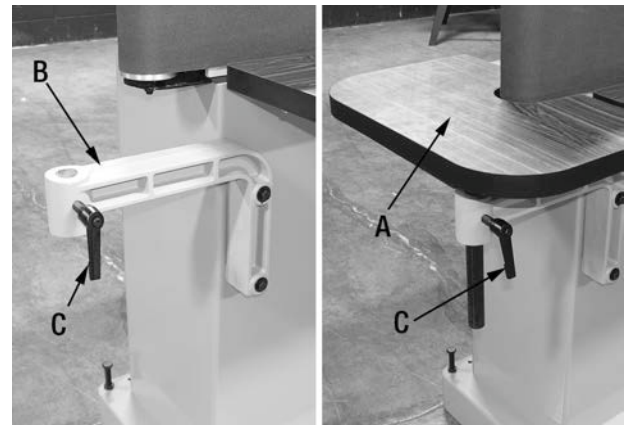

FIGURE 6

## USING A DUST COLLECTOR FOR DUST CONTROL

**CAUTION:** For health reasons, never operate this sander without an adequate dust collection system connected and operating.

This edge sander comes with a 4" dust chute (A) Fig.7 and is intended for use with a 4" hose connected to a dust collector (not included). If you do not own a dust collector, visit our web site [www.kingcanada.com](http://www.kingcanada.com) or visit your King Canada retailer for information on our line of dust collectors.



FIGURE 7

# ADJUSTMENTS & CHANGING SANDING BELT



## SANDING BELT TRACKING ADJUSTMENT

**Warning!** Disconnect power from power source before attempting to adjust this edge sander.

To prolong the life of the sanding belt and to avoid any slippage of the belt off the drums, proper sanding belt tracking is important to maintain the sanding belt running straight on the drums. To adjust sanding belt tracking:

- 1) Make sure the sanding belt (A) Fig.8 is properly tensioned, the tension lever (B) must be positioned to the right as shown.
- 2) Turn the edge sander On for a few seconds and observe the tracking of the sanding belt.
- 3) If an adjustment is needed, move the tension lever (A) Fig.9 completely to the left "loose" position as shown.
- 4) Lift the belt tracking locking lever (B) Fig.9 and turn the adjustment wheel (C) to adjust belt tracking. Turn adjustment wheel clockwise to track belt downwards on the roller, turn counterclockwise to track belt upwards on the roller.
- 5) Lower belt tracking locking lever (B) Fig.9, move the tension lever (A) completely to the right "tensioned" position. Turn the edge sander On for a few seconds and observe the tracking of the sanding belt. Repeat until sanding belt is tracking properly.

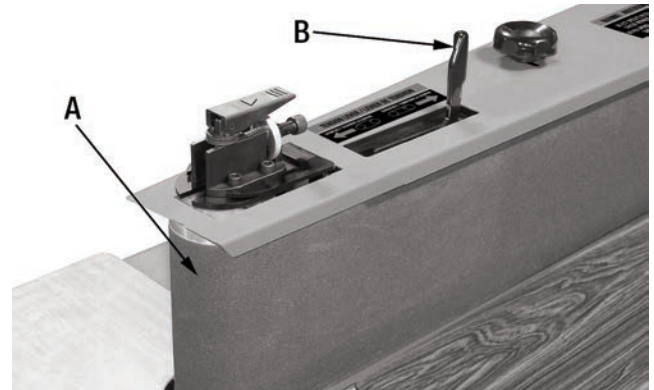

FIGURE 8

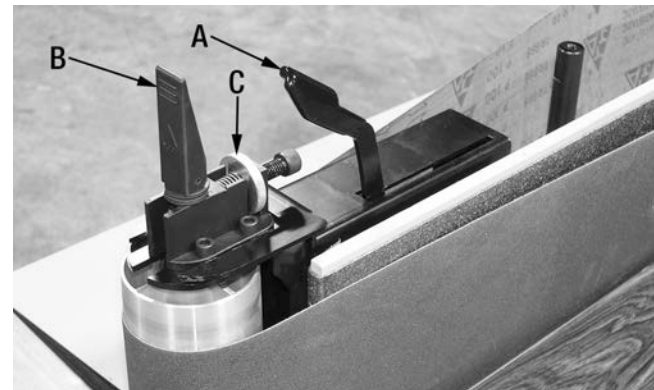

FIGURE 9

## ADJUSTING THE STEEL PLATEN

**Warning!** Disconnect power from power source before attempting to adjust this edge sander.

The steel platen (A) Fig.10 should be positioned 1/8" to 1/4" in front of the drive roller and the idle roller. The steel platen is set properly at the factory but after time an adjustment may be needed. To adjust the position of the steel platen:

- 1) Remove the sanding belt, refer to the next section below "Changing Sanding Belt" for instructions.
- 2) Loosen the two hex. bolts (B) at the rear of the steel platen.
- 3) Using a straightedge or a combination square, position the steel platen from 1/8" to 1/4" in front of both rollers.
- 4) Retighten the two hex. bolts (B) at the rear of the steel platen and reinstall sanding belt.

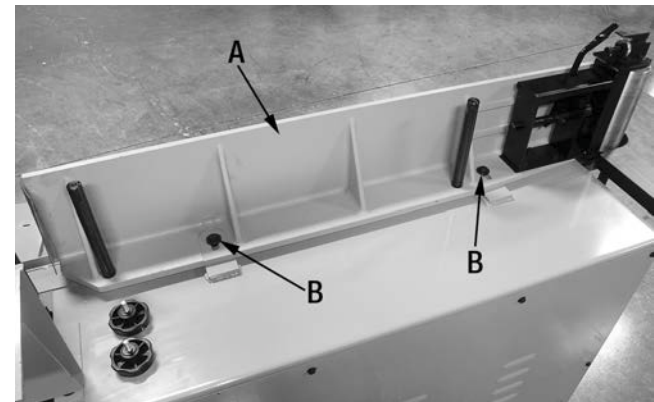

FIGURE 10

## CHANGING THE SANDING BELT

**Warning!** Disconnect power from power source before attempting to change the sanding belt.

A sanding belt should be changed when it has worn out. Follow these instructions to change a sanding belt:

- 1) Open the right side safety guards (A) Fig.11 by unclipping the two retaining clips and flipping the safety guards backwards.
- 2) Loosen and remove the two lock knobs (B) and then remove the belt access cover (C).

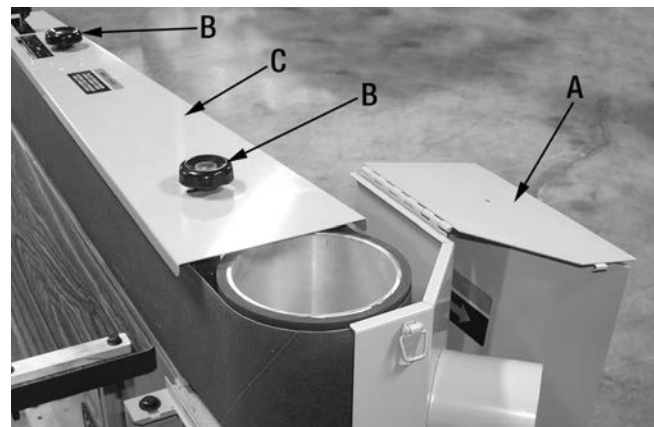

FIGURE 11



# CHANGING SANDING BELT & MAINTENANCE

## CHANGING THE SANDING BELT continued....

**Warning!** Disconnect power from power source before attempting to change the sanding belt.

- 3) Pull the tension lever (A) Fig.12 completely to the left “loose” position as shown.
- 4) Remove the used sanding belt from both rollers.
- 5) The sanding belt runs counterclockwise on the rollers, before installing a new sanding belt on the rollers, make sure the arrows on the inside of the sanding belt correspond to the belt rotation label on the safety guard on the right side of the machine.
- 6) Place and centre the new sanding belt around both rollers. Tension the sanding belt by pulling the tension lever (A) Fig.12 completely to the right “tensioned” position.
- 7) Reinstall the access cover and secure it with two lock knobs. Close both safety guards and secure them with their retaining clips.
- 8) Once a new belt has been installed, check sanding belt tracking and adjust if necessary.

## MAINTENANCE

**Warning!** Disconnect power from power source before any maintenance operations.

### CHANGING GRAPHITE PAD ON THE STEEL PLATEN

The graphite pad (A) Fig.13 will wear down and will eventually require replacement once visible signs of wear are apparent. To change graphite pad:

- 1) Following the instructions for removing the sanding belt.
- 2) Pull the old graphite pad (A) Fig.13 off the steel platen. A strong solvent may be required to unglue the graphite pad from the steel platen.
- 3) Install a new graphite pad on the steel platen. Some graphite pads have adhesive backings, some will require using contact glue.

### TIMING BELT TENSION ADJUSTMENT/REPLACEMENT

Over time the timing belts which transfer power from the motor shaft to the drive roller for oscillation movement may require tensioning. Loose timing belts will cause intermittent operation of the oscillation feature and cause excessive noise and vibration. In such situation the timing belts will need to be tensioned.

- 1) Loosen hex. nut (A) Fig.14.
- 2) Turn the hex. bolt (B) clockwise then retighten the hex. nut (A).
- 3) If a timing belt should break and replacement is required, loosen and remove four hex. bolts (C) under the motor assembly and remove the cover (D). Replace timing belt(s). Reinstall cover.

## LUBRICATION

### SANDING BELT TENSION MECHANISM

It is important to keep the sanding belt tension mechanism (A) Fig.15 lubricated and free of dust and debris. Clean mechanism and reapply all purpose grease to the spring and shaft every 6 months or as needed.

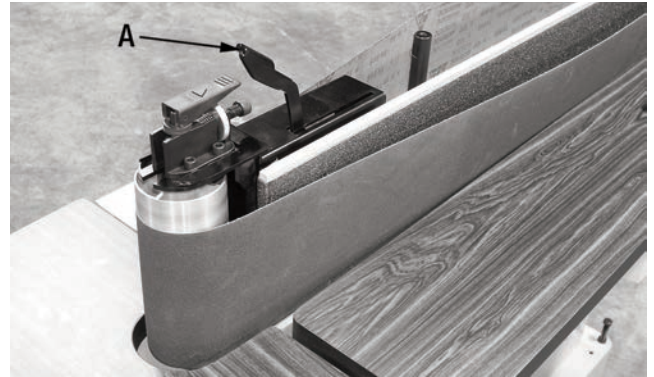

FIGURE 12

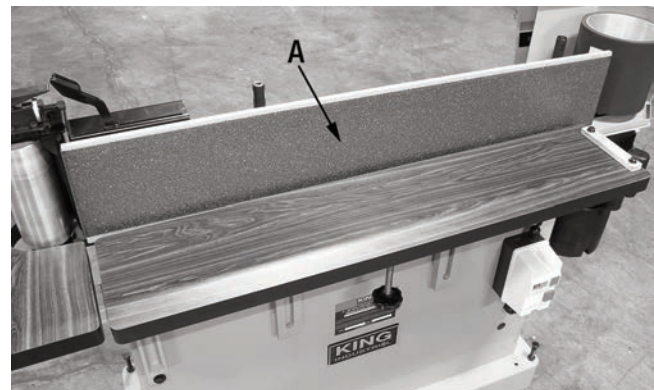

FIGURE 13

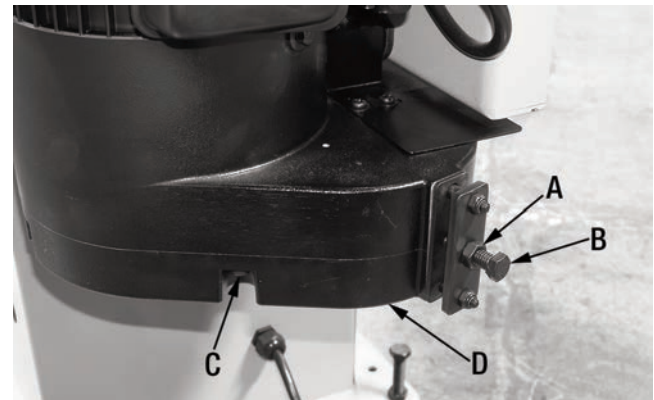

FIGURE 14

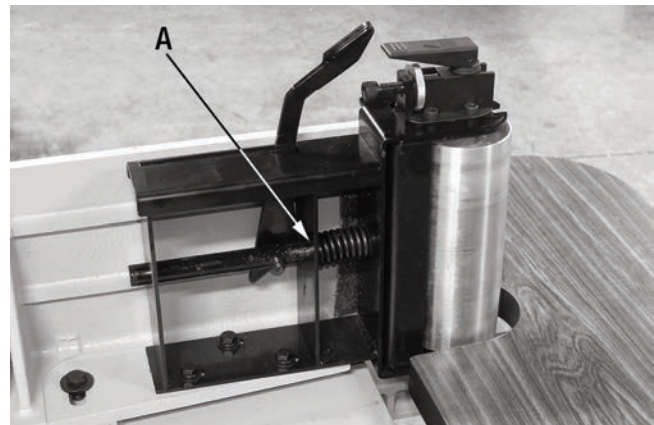

FIGURE 15