



WARRANTY

Novatto products have been made under the highest standards of craftsmanship and quality. All Novatto showers are backed by Novatto's Lifetime LIMITED warranty. Novatto warrants to the original consumer purchaser for as long as the original consumer purchaser owns their home (the "Warranty Period" for homeowners), this showers will be free from defects in material and workmanship. All other purchasers (including purchasers for industrial, commercial and business use) are excluded from this warranty.

Damage due to installation error, product abuse, product misuse, or use of cleaners containing abrasives, alcohol or other organic solvents, whether performed by a contractor, service company, or yourself are excluded from this warranty. Novatto recommends using a plumbing professional to install your Novatto product. Except as provided by law, this warranty is in lieu of and excludes all other warranties, conditions and guarantees, whether expressed or implied, statutory or otherwise, including without restriction those of merchantability or of fitness for use.

Defects or damage caused using other than genuine Novatto parts is not covered by this warranty. This warranty is applicable only to showers purchased after November 2019 and shall be effective from the date of purchase as shown on purchaser's receipt. If the showers should leak or drip during normal use, Novatto will provide the purchaser the cartridge necessary to put the showers in normal working condition within the first year. All finishes on showers are warranted to the original consumer to be free from defects in material and craftsmanship for a period of one year starting the date of purchase by the consumer. If the showers is used commercially or is installed outside of the United States of America or Canada, the warranty is voided.

Get the most out of your Novatto faucet by registering!

By registering, you are also establishing the product's warranty. Plus you will receive product information, helpful tips, learn of special events and much more.

Proof of purchase (original sales receipt) must be provided to Novatto, Inc. with all warranty claims. Novatto is not responsible for labor charges, installation, loss, injury or any other incidental or consequential costs. In no event shall the liability of Novatto products surpass the purchase price of the replacement part. In no event shall Novatto be liable for loss of profits or any such loss, or any direct or indirect, special, incidental or consequential damages howsoever incurred or designated arising out of any breached claim of warranty.

If you believe you have a warranty claim, contact Novatto, either through your local Dealer, Plumbing Contractor, Home Center, or by writing: Novatto, Inc., Attn: Product Support, 3533 E. Corona Ave., Phoenix, AZ, 85040, USA. Please be sure to provide all pertinent information regarding your claim, including a complete description of the problem, the product, model number, color, finish, the date the product was purchased and from whom the product was purchased. Also include your original invoice. For other information, or to obtain the name and address of a service or repair facility near you, email: support@novatto.com or write to the above address.

Warning: Never use cleaners containing abrasive cleansers, ammonia, bleach, acids, waxes, alcohol, solvents or other products not recommended for chrome, oil rubbed bronze or brushed nickel. This will void the warranty. Novatto products may be cleaned by using a mild soap with warm water and a dry, clean soft cloth. Using anything other than what is suggested will void the warranty.

ASSEMBLY WITH DIVERTER DIAL

Steps to Complete Your Faucet Install

Applicable for the following shower tub series:

TBS-18023-TS TBS-18015-TS

Please Note:

- Review and abide by all building and plumbing codes.
- Standard codes for Novatto showers: cUPC/CSA/AB1953
- Novatto shower/tub systems need to be installed by a professional.
- The valve comes with a black plastic cover plate that serves as a guide for the depth at which the valve must be set.
- Block the shower drain to prevent small parts from falling into it. Place a blanket or piece of cardboard on the floor of your tub to protect against dropped tools.

• We **highly** recommend using a professional when installing shower and tub faucet and plumbing.

• **Prepare the bath area for installation:** It is assumed the water is turned off at the source, old fixtures have been removed and water supply lines (not included) are in the proper installation location. Also, verify that the hole sizes and positions of the old fixtures in the wall are correct.*

* **Recommended component measurements:** Shower and spout outlet hole: 1" diameter

• **Remove existing shower valve** and fixtures. Clear any debris. Clean old sealant from any threaded connections.

• **Remove the black cover plate (6)**, by unscrewing the two screws(7) that attach the plastic cover plate(6) to the valve body(5). Place it back on the valve's body(5) loosely to protect it.

• **Install the valve body(5) keeping the plastic cover plate on.*** Wrap plumber's tape (not included) around the threaded section of the pipes (not included) in a clockwise direction to ensure a watertight seal. Connect the water supply lines (not included), the tub outlet pipe (not included), and shower outlet pipe (not included) to the valve body (5). Tighten the pipes to the valve body.

* **Important:** Take into consideration the thickness of your wall. If the valve is installed too far behind the finished wall, you may be left with insufficient clearance to attach the handle, diverter and plate.

Recommended valve depth to finished wall: 2" min. to 2.5" max. Ensure that the plastic black cover plate's surface is flushed with the finished exterior surface of the wall. Position the valve body correctly into the wall.

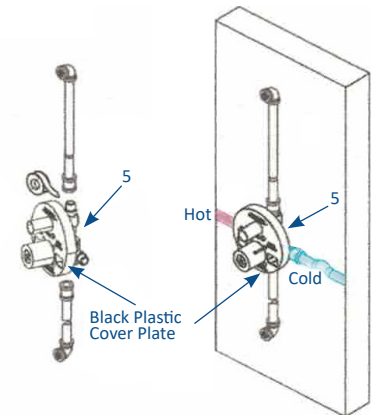
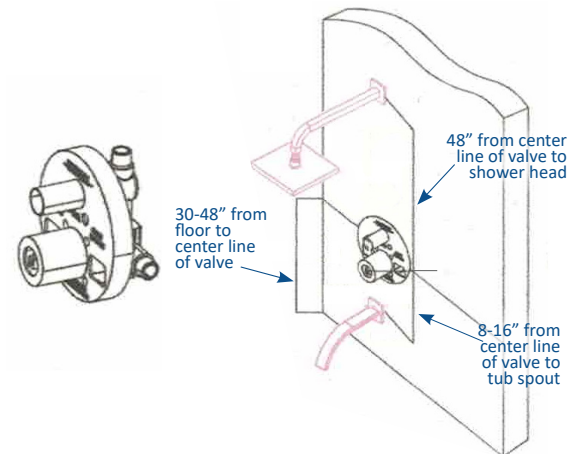

TROUBLESHOOTING TIPS

Issue	Reason	Solution
Need to access plumbing lines	Hot/cold lines connected incorrectly	Ask your plumber to install an access panel in case you need to get in
Leaking from under the handle	Dirt and debris collected in the valve/cartridge	Blow out pipe/hoses; Might have to replace the valve/cartridge
Finish is changing color or is shiny	Abrasive cleaners, soaps or other factors constantly in contact with it.	Stop using abrasives; Replace parts
Low Water Pressure/Flow	Shut-off valves not open all the way; Debris or air-pockets in pipes	Check the shut-off valves, must be open all the way; Blow out pipe/hoses

DIAGRAM AND PARTS LIST

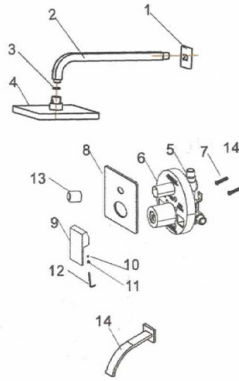

1. Trim
2. Shower arm
3. Gasket
4. Shower head
5. Valve body
6. Cover plate
7. Tapping screw
8. Panel
9. Handle
10. Screw
11. Red/ blue button

12. Allen key
13. Diverter
14. Spout

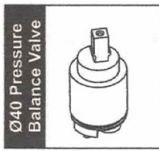

Black Plastic Cover Plate

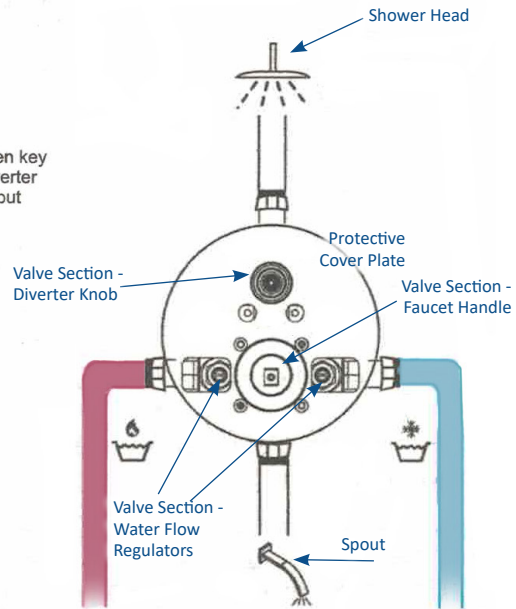
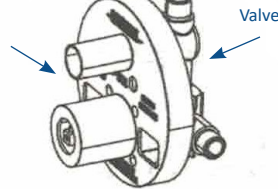

- **Remove the black plastic cover plate.** Install handle(9) and diverter(13) onto valve(5). Install the shower trim(1), arm(2) and tub spout(15). Wrapping plumber's tape (not included) around the threaded section of the pieces in a clockwise direction to ensure a watertight seal. **STOP!***
- **Test for leaks. With handle(9) in the Off position,** turn on water slowly from source. Test for 3 mins. Place handle (9) in *On* position. Test for 3 mins. switching from tub to shower with diverter(13). If no leaks, shut off the water at the faucet and supply lines. Remove diverter(13) and the handle(9), put black plastic cover plate back on loosely to protect valve as you finish up.*

TIP: The valve body comes with water flow regulators. If there is some deviation between the cold and hot water flow, you may adjust by turning the hex nuts

* **Important:** COMPLETE CONSTRUCTION OF THE SECTIONS, INCLUDING ANY FINISHED WALL MATERIALS SUCH AS TILE, BEFORE PROCEEDING WITH THE REMAINDER OF THE INSTALLATION. **STOP!***

- **Once the finished areas are complete,** attach the shower head(4) with the gasket(3), to the arm(2) using a wrench. Remove the black plastic cover plate(6) from the valve.

TIP: Place a cloth between the wrench and shower head to avoid damaging the finish.

- **Remove small hot/cold indicator button(11)** on handle, to reveal small hexagonal socket and an Allen screw(10). You might have to loosen it, using an Allen wrench (not included), in order to attach the handle to the valve body(5). Place the escutcheon plate(8) firmly over the valve. Attach the diverter(13) knob to the valve. Align the Allen screw(10) in the handle, to the hole in the valve body. Once handle is in place, tighten the Allen screw(10) underneath to secure it to the valve body. Replace the small hot/cold indicator button(11). (Red on left, blue on right.)

- **When the installation is complete,** turn the diverter knob to tub, and the handle to the "mix" position, then slowly turn the main water supply lines to their full open position and allow the water to flow, switching from tub to shower, until all foreign matter has been flushed out of the line. Run hot and then cold for one minute each. Adjustments might need to be made at the main water supply lines for your desired flow rate.

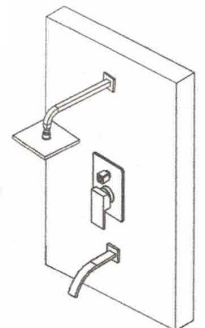
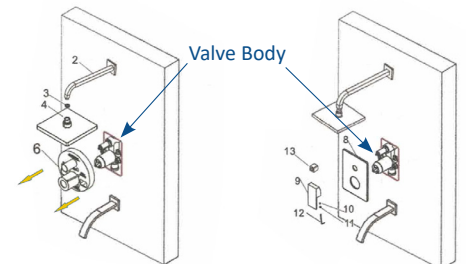
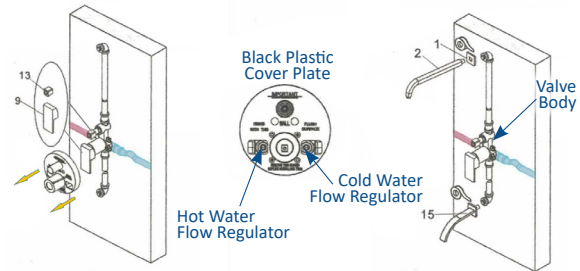

TOOLS NEEDED FOR ASSEMBLY (not included)

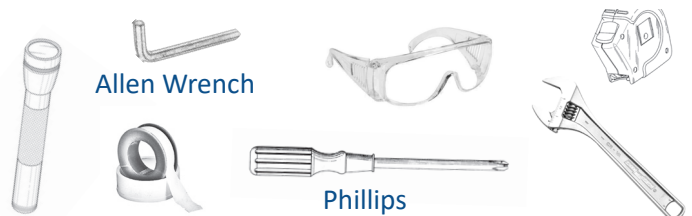

Questions, problems, missing parts? Before returning to your retailer, call our customer service department at 844.404.4242, 9:00 a.m. - 5 p.m., MT, Monday - Friday or email us at: support@novatto.com



Glacier Ice Faucet and Sink professional sealer kit will not only restore/clean sinks, faucets and shower systems from mineral build-up and hard water spots, it will also protect from future corrosion, oxidation, mold and mildew. Treats up to 100 square feet.

How should I care for my shower system?

For the absolute best cleaning results, clean your shower system right after install and then use the Glacier Ice Sealer kit. This will help seal the system and help prevent hard water spots and mineral build up*. After that, cleaning will be easy. Just use a soft cloth or sponge with mild soap and water, rinse and dry. Do not use abrasive cleansers, or cleaners containing ammonia, bleach, acids, waxes, alcohol or other solvents. Remember, the effectiveness of all cleaners depends on factors like water hardness, temperature and condition of the item being cleaned.

**Don't forget to rinse and dry off any excess cleaner which may have landed on adjacent surfaces.*

FAQs

Can I install the shower system myself?

The complexity of installing a shower system can vary depending on your plumbing knowledge and skills. Some systems may be relatively simple, while others may require a professional. Novatto highly recommends you hire a professional. It is important to assess your capabilities before attempting an installation.

When installing a new shower system, can I reuse my existing pipes, shower fixtures, water supply lines?

Depending on the compatibility of your existing installation with your new shower system, you may be able to reuse some components. However, it is critical to check the compatibility and specifications of your existing installation to your new system in order to ensure proper operation and compatibility.

Do I need to make changes to the existing plumbing in order to install my new shower system?

The degree of modification required depends on your current plumbing setup and the type of shower system you are installing. In some cases, you may need to add new pipes, divert water pipes, or adjust water pressure. If you are unsure whether to make plumbing changes, it is **highly** recommended that you consult a professional.

Do I need to hire a professional to install the shower system?

It is not always necessary to hire a professional plumber, but it can be beneficial, especially if you have limited plumbing knowledge or are dealing with something complex. Professionals can ensure proper installation, resolve any potential issues and provide valuable expertise. It is best to consider your own abilities and consult a professional if needed.

More questions? Feel free to contact our technical support team, Monday - Friday 9:00 a.m. - 5 p.m., MT, P: 844.404.4242, or email us at: support@novatto.com. More info is also available on our [website](#).

THANK YOU

We would like to take this opportunity to thank you for choosing Novatto. We hope you are truly satisfied with our product and enjoy it for years to come. As a small business, we learn the most from you, the customer. Please visit the link to the right, leave us a review with high resolution pictures and you could win a \$25 Amazon or Visa gift card.

It's easy as...

- Go to novatto.com
- Find your product's page
- On the right, about 1/2 way down, click "Write a review"
- Review, submit and let your style flow

NOVATTO
WHERE STYLE FLOWS

Novatto | P: 844.404.4242
support@novatto.com
Novatto.com

