

# MINIMAX

## THE MAXIMUM IN MINIMUM SPACE



The MINIMAX tunnel is the solution with extremely compact dimensions for small spaces (just over 9 meters in minimum configuration) and excellent productivity: complete, reliable and innovative.

MINIMAX has been designed for washing performances up to 30 cars per hour and the three basic configurations designed by Ceccato make it an ideal tool for maximum profitability in relation to price and operating and maintenance costs.

### MINIMAX OFFERS:

- Unique, modern, eye-catching design that will capture the attention of your customers;
- versatility of installation and unsurpassed use, made possible by self-supporting structure;
- The safety of the protections and side covers;
- Full and accurate washing and drying, with qualitative results comparable to those obtained from high-end gantries, but with about twice the productivity;
- The choice of optional washing accessories for even better results;
- The sophisticated brush control software and the patented Air Plus Drying System, combining the top of the technology with an unsurpassed simplicity.



MINIMAX

MINIMAX  
Power and elegance

## STRUCTURE

Structures are self-supporting, fixed to the floor with expansion dowels. The steelwork is made in hot galvanized steel, with screw-in bolts and self-locking stainless steel nuts. The coating is of polyurethane powder type, deposited electrostatically and polymerized with a high temperature oven.

## ELECTRICAL EQUIPMENT

The electrical system is made according to the current European regulations, the electrical components of the leading international brands are of high quality. The entire system is managed by programmable logic (PLC). The vehicle counters are password protected. The installation can operate with power supply: 400 Volt + 10% and 50/60 Hz frequency.

## HYDROPNEUMATIC EQUIPMENT

The pneumatic circuit is equipped with pressure switch. The water supply is split: it is designed to feed the plant both with fresh and recycled water. The system is equipped with manual flow regulators on each spray arc and with automatic condensate drainage from the inlet air filter.

## CHEMICAL DOSAGE SYSTEM

The system is equipped as standard with adjustable pneumatic dosing pumps for the dispensing of Shampoo, Foamed Shampoo and Wax.

## WINTER DISCHARGE

The system is equipped with solenoid valves for winter drainage of the water circuit, against possible winter frosts. The activation takes place via a guided choice from the operator panel and temperature probe.

## LEARNING

It is possible to set or modify, directly on the installation, the running times of the various stages of the washing and drying cycle. The operation can be done through the Operator Panel in the activation panel of the system. The device allows to communicate directly with the PLC from the washing plant. The operator can easily read or modify the data on the PLC itself.

## SELF-DIAGNOSIS

The system software monitors the operation of all parts of the washing plant. In the event of a failure, the control device displays an error code indicating the cause of the failure. This function often prevents the intervention of the Technical Assistance Service or, in any case, makes the intervention more efficient as the call can give the operator more accurate information on the nature of the failure. The HERCULES line applies the "fault-tolerant" philosophy: the total shutdown of the system happens only in case of failures that concern the main parts necessary for the washing cycle and for the safety of people or things. In other cases, the failure is signaled by the diagnostic device, and the cycle continues with the self-exclusion of the failed part.

## CONFIGURATIONS

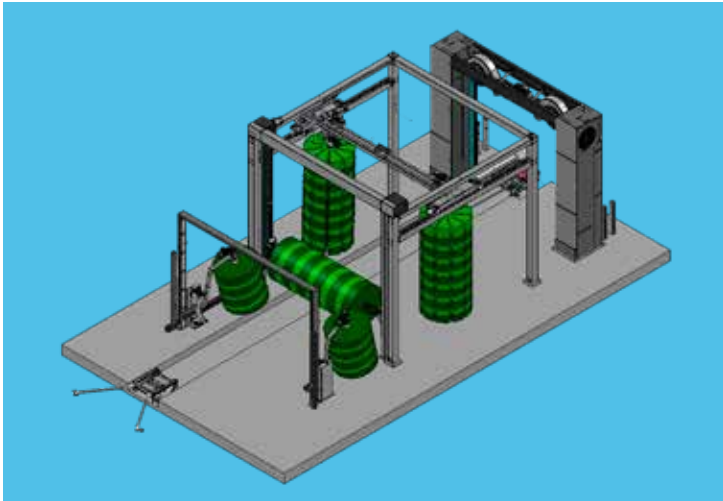

**MINIMAX DYNAMIC  
CONVEYOR**  
LENGTH OF 10,40 M

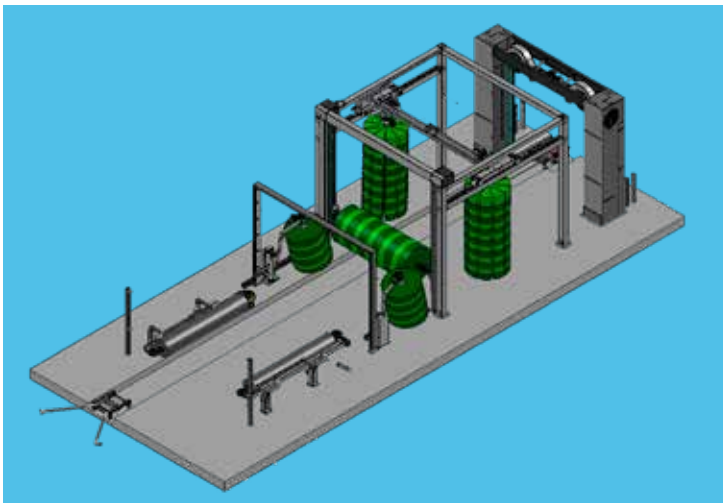

**MINIMAX SMART  
CONVEYOR**  
LENGTH OF 14,15 M

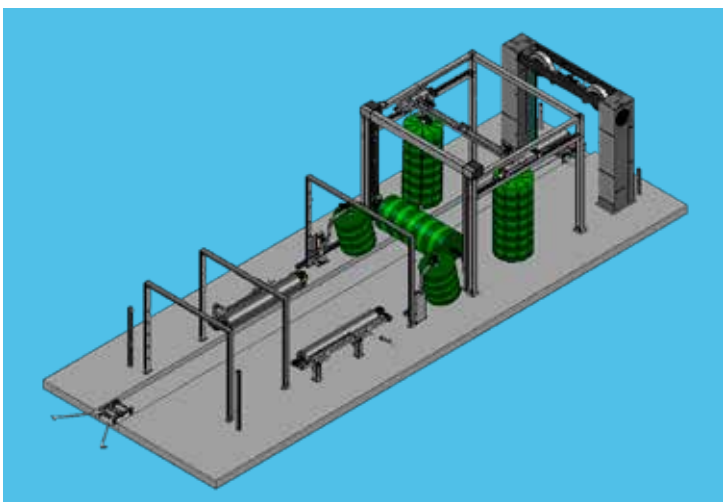

**MINIMAX EDITION  
CONVEYOR**  
LENGTH OF 16,40 M

## CONFIGURATION

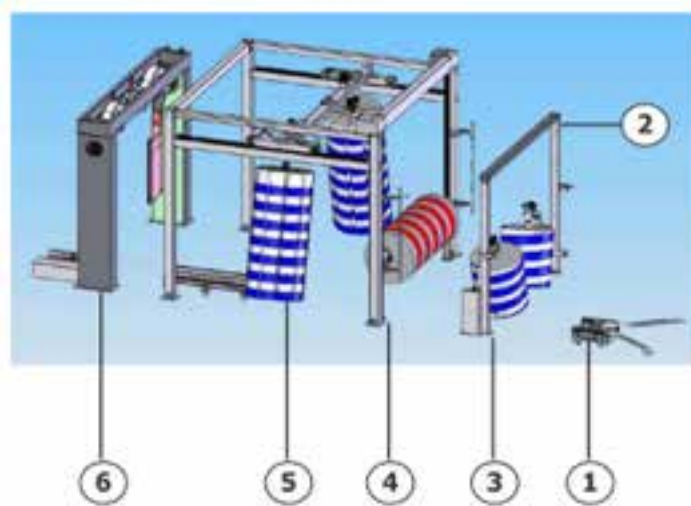

The basic configuration of the system consists of five main sections:

1. Conveyor;
2. Entry with wetting section with shampoo;
3. Wash section with inclined vertical half brushes;
4. Washing section with horizontal brush
5. Washing section with translat vertical brushes;
6. Drying section.

## ENTRY

At the entrance of the tunnel there is the photocell system to detect the vehicle presence (1) and to identify whether the vehicle is a van (2). When the vehicle is in position, the automatic cycle can start.

The start of the cycle coincides with the departure of the towing chain and with the start of the vehicle position control system throughout its path inside the tunnel. Position control allows the startup sequence of the workgroups. A traffic light at the entrance of the tunnel regulates the vehicle's access.

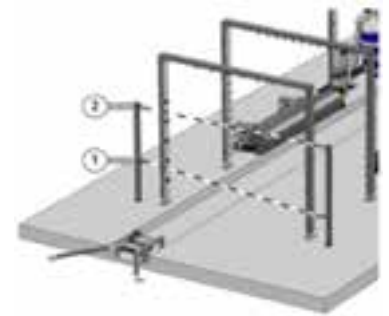

## TOWING GROUP

The towing group consists of a motorized chain equipped with a number of appropriately spaced rollers. Chain movement is carried out by a fixed speed gearmotor. Once the vehicle is positioned with the gearbox in neutral, the roller engages the left front wheel and pushes it forward by moving the vehicle itself. The structure is embedded within a canal arranged on the floor. At the beginning of the chain is placed the wheel guide which has the task of facilitating the introduction of the wheel. On the sides of the towing chain are the metal grids placed at the closure of the containment channel (1).



## VEHICLE SURFACE TREATMENT SECTION



### SHAMPOO - FOAM ARC

Before the activation of the brushes, the surface of the vehicle is wet with shampoo dispensed by two columns of side nozzles.

The same arcade integrates the foam nozzles.

We do not recommend simultaneous use of the two products.



### HALF VERTICAL BRUSHES GROUP

The first group that activates when the vehicle arrives is the two half tilting brushes mounted each on a structure that can rotate at 90° towards the center of the tunnel. Brushes are initially at the center of the tunnel and gradually open to the vehicle passage to close again on the back of the vehicle.

During rotation the brushes are wet with a series of nozzles applied to the structure as shown in the picture. The water used in this phase is normally recycled water.



### HORIZONTAL BRUSH

The second group in sequence is the horizontal brush equipped with vertical movement.

The group is composed of the following parts:

- 1 - Brush;
- 2 - Gearmotor for brush rotation;
- 3 - Flat lifting belt;
- 4 - Gearmotor for brushes group lifting.

During rotation the brush is wet with recycled water dispensed by an horizontal arc (5) applied to the upper crossbeam.

During the brush rotation, the engine absorption is checked to detect anomalies that could be caused by collisions or clogging of the bristles with the vehicle's edges.

## TRANSLANT VERTICAL BRUSHES

It's the third working group and consists of two independent vertical rotating brushes mounted on a longitudinally mobile motorized trolley. Each brush can move freely along the guides of the trolley's crossbeam thanks to a motorized unit.

The longitudinal run of the trolley is 2200 mm.

### COMPOSITION

1. Vertical brushes;
2. Trolley moving longitudinally;
3. Gearmotor for brushes rotation;
4. Gearmotor for transverse brush movement along the trolley crossbeam;
5. Gearmotor for the longitudinal movement of the trolley.
6. Tire clamp for the vertical brush tilting.

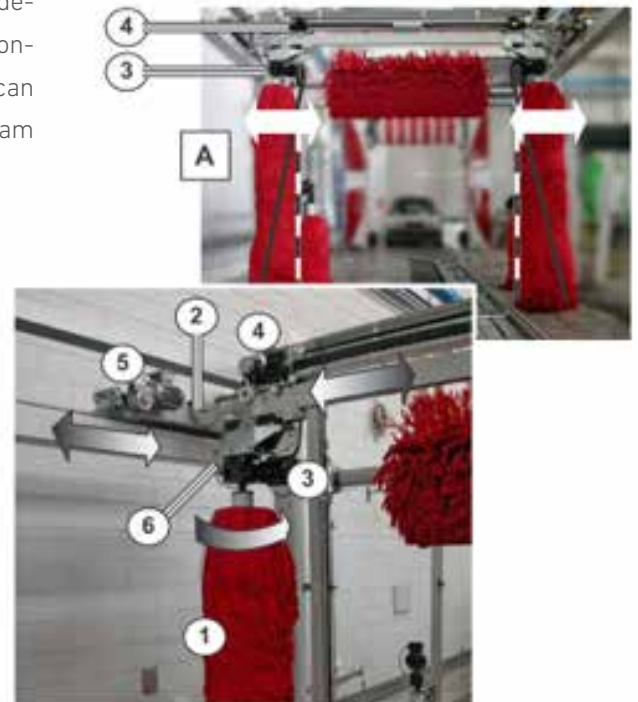

### FUNCTIONING

At the beginning of the cycle, the brushes are positioned on the center line of the tunnel. The washing of the front of the vehicle starts with a series of alternating movements to the right and to the left ("ballet"). During this phase the trolley moves with the vehicle and in proximity of the limit switch, the brushes are positioned at the corners of the front of the vehicle. At this point the brushes incline, thanks to the action of pneumatic jacks.



The inclined position allows a more effective bristle action on the upper part of the vehicle, since the lower part has previously been washed by the first group at the entrance. During this phase the trolley moves longitudinally to prepare for a new run. The direction of rotation of the vertical brushes is inverted before washing the back of the vehicle. The back of the vehicle is washed in the same way as the vehicle front.

At the end of the cycle, the brushes are located centrally and the carriage is in the back position awaiting the next vehicle. During rotation, the brushes are wet with nozzles (6) mounted on the crossbar of the carriage. Engine absorption is also checked to detect anomalies that could be caused by collisions or clogging of the bristles with the vehicle's appendages.



## WAX ARC

Through this system, the vehicle is wetted with a mix of fresh water and wax that, on the vehicle surface, replace the water used during the washing cycle. In this way water drops, that by nature don't adhere to the vehicle surface, easily glide under the action of the air flows, produced by the following drying group.

## DRYING GROUP

The drying group is divided in two working sections, a vertical and an horizontal one.

1. The horizontal section is made by two blowing blades built on a motorised device, creating a rotating swing around its axe, with variable speed. Each blade is feed by a 3kW fan. The blade's diameter is 180 mm;
2. The vertical section is composed by two vertical counterposed blades, integrated in the columns. These are equipped by a fan of 3kW (or 4kW for the 60 Hz version) installed on the top of the same columns.

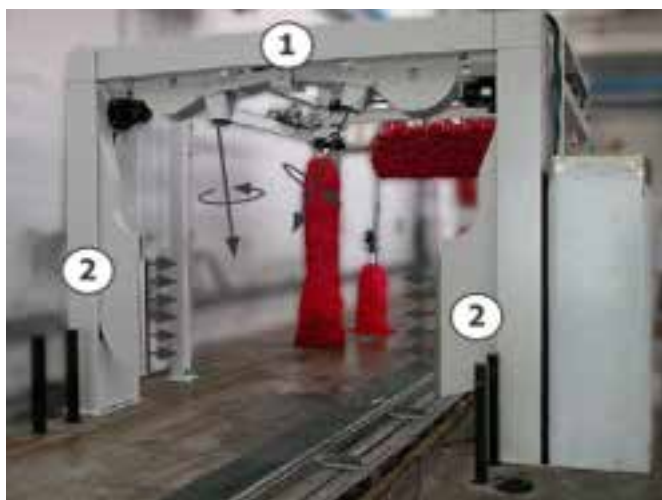

## OPERATING LIMITS WASHING UNIT DIMENSIONS

DRIVE THROUGH DIMENSIONS	
Max passing height	2300 mm
Max passing width	2200 mm

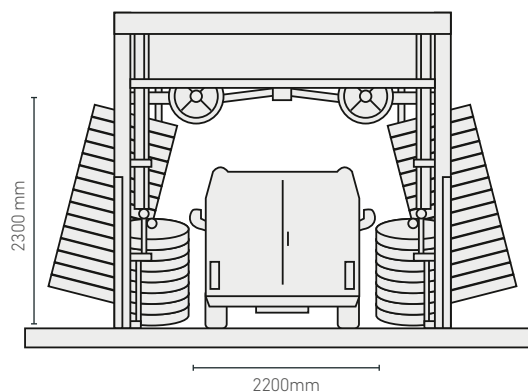



Ceccato S.p.A.  
Via Selva Maiolo 5/7  
36075 Alte Ceccato  
di Montecchio Maggiore  
Vicenza - Italy

t +39 0444 708 411  
f +39 0444 708 405  
info@ceccato.it  
www.ceccato.it

Technical data are subject to variations; the Manufacturer reserves the right to update the documentation, without any obligation to inform the customer about the changes. Pictures are not binding - for information only - subject to technical changes without prior notice.

CARATTI/POLETTO ADV