

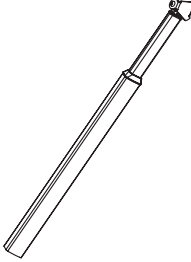









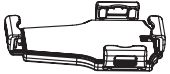

Parts Included:

Part No. / Description	Qty	Part No. / Description	Qty
 <p>A pole</p>	1	F  plastic pad	1
		G  M5x8(tamper-proof screw)	1
		H  EVA pad	2
B  clamp holder	1	I  ST5.5x38	4
C  base	1	J  concrete anchor	4
D  key	1	K  Allen key	1
E  M6x16	4	L  TORX tool	1



Set-up:

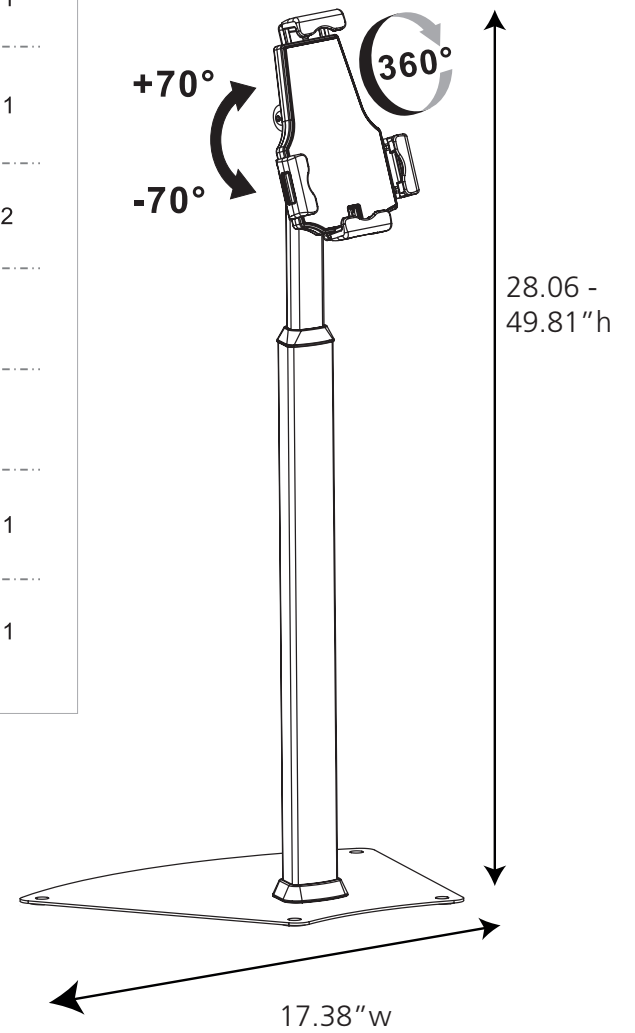
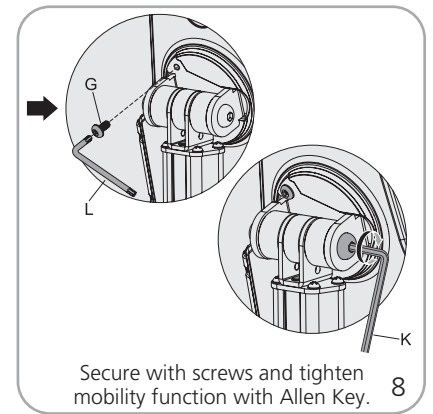
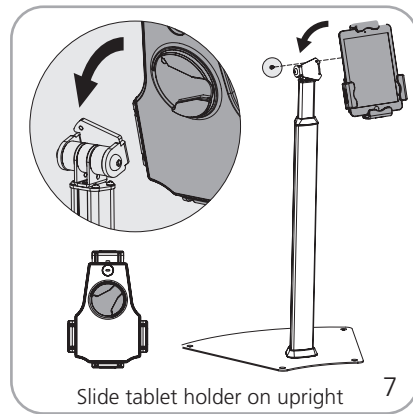
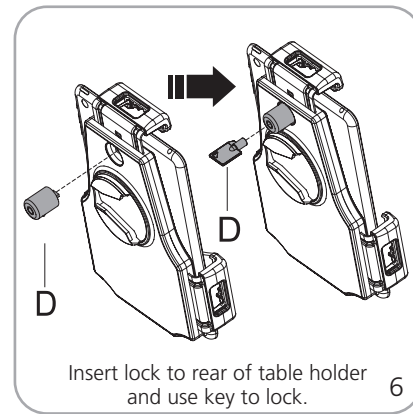
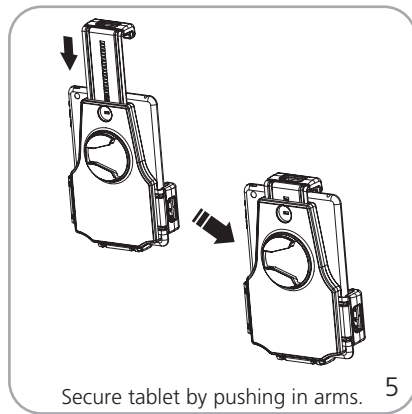
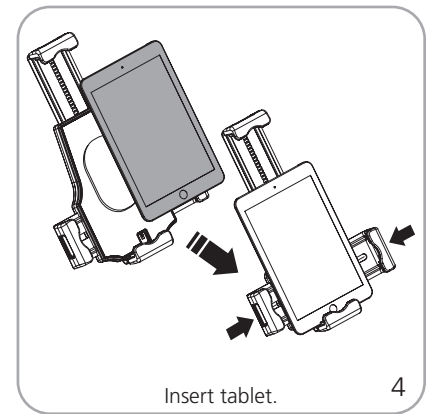
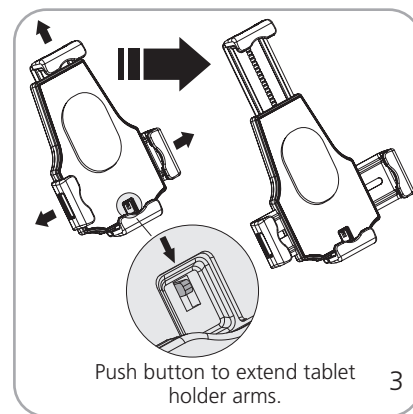
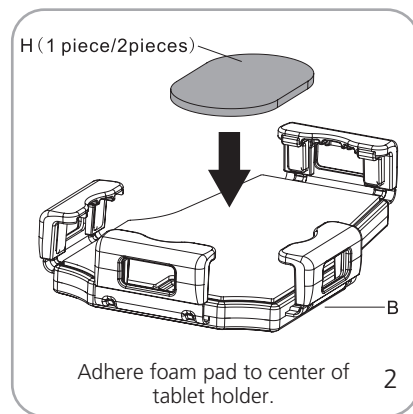
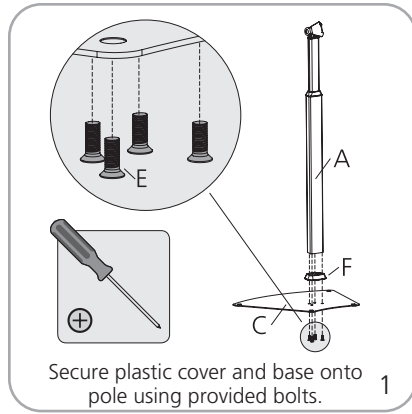

Optional Base Attachment:

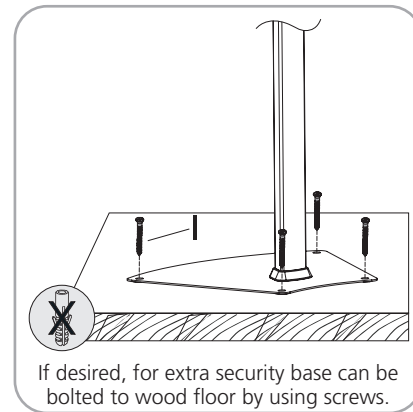
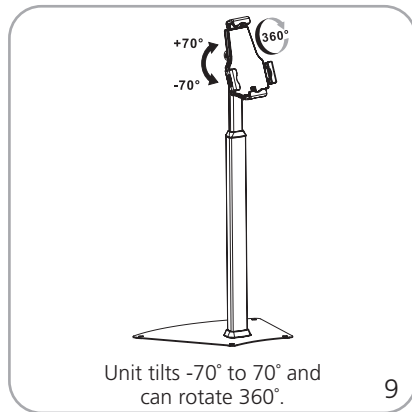

Optional Base Attachment:

